

## RTS20x Series Raman Zoom Lenses

Raman Accessory



This series of lenses is equipped with long working distances from 20 mm to 6 meters, which expands the utility of our BAC100/BAC102 fiber optic Raman probes for stand-off measurements in places that may be inaccessible with a standard probe. The lenses have adjustable working distances and provide a wide zoom, and even telescopic measurements, with various models available, each optimized for different Raman excitation ranges. The long working distances allow for process monitoring behind optical glass such as glass vacuum chambers, and analysis of samples in difficult-to-access places such as may be found in archaeological sites. The model with working

distance up to 6 meters allows for stand-off measurements such as needed for energetic materials. The lenses can be mounted on a tripod (optional) using a standard 1/4"-20 thread mount.

These lenses have a working temperature range of -30°C to +50°C.

### Applications:

- Stand-off measurements of energetics
- Process monitoring through thick-walled glass reactors
- Noncontact high temperature, high pressure measurements
- Archeological measurements in ruins, buildings and other structures
- Noncontact measurement of art works



### Specifications:

Model	Name	Suitable Raman Excitation Range	Working Distance (adjustable)	Aperture Diameter	Focused Laser Spot Diameter	Weight
RTS200-VIS-NIR	Zoom Lens 20 – 60 mm	500 – 850 nm	20 – 60 mm	23 mm	~0.21 mm @ 20 mm ~2.3 mm @ 60 mm	0.8lbs
RTS200-NIR	Zoom Lens 20 – 60 mm NIR	785 – 1064 nm				
RTS201-VIS-NIR	Zoom Lens 60 – 600 mm	500 – 850 nm	60 – 600 mm	48 mm	~0.22 mm @ 60 mm ~2.6 mm @ 600 mm	2.2lbs
RTS201-NIR	Zoom Lens 60 – 600 mm NIR	1000 – 1100 nm				
RTS202-VIS-NIR	Stand-off Lens 0.6 – 6 m	500 – 850 nm	0.6 – 6 m	70 mm	~0.6 mm @ 0.6 m 8.5 mm @ 6 m	4lbs



**Dimensions:**  
**RTS200:**

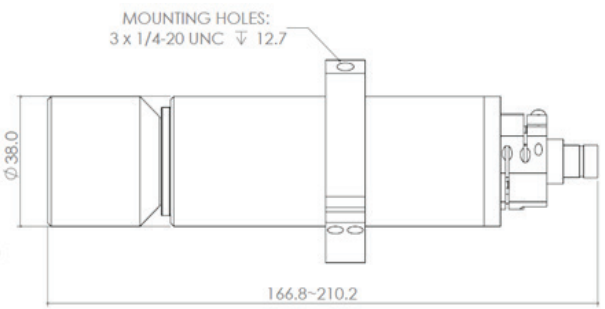
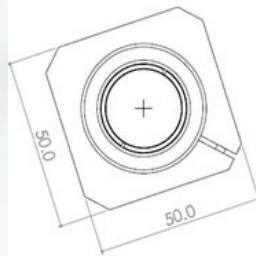

**RTS201:**

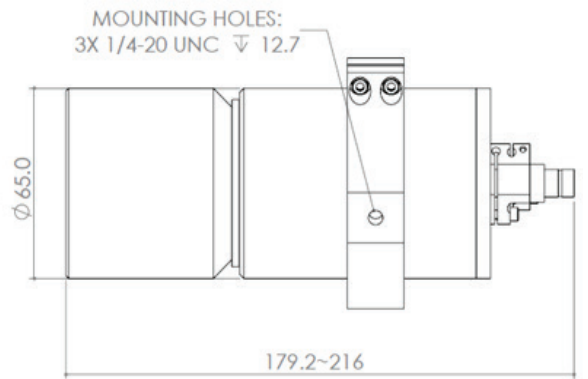
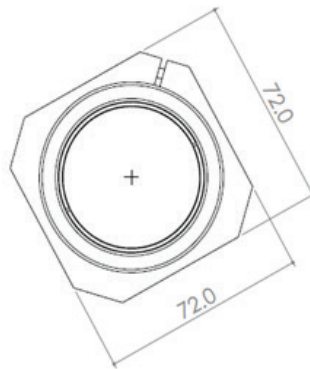

**RTS202:**

