

BAC101 Industrial-Grade Raman Probe

Raman Accessory



The BAC101 is an immersion Raman probe designed for in-situ analysis including those in demanding industrial environments.

The BAC101 industrial-grade probe is available with shafts of 316SS or Hastelloy C-276, offering a wide range of operating temperatures and chemical compatibility. They are offered for use with our 532 and 785nm excitation portable Raman instruments, and high-throughput (HT) versions are available for optimal performance with the i-Raman Prime series high-throughput instruments. Due to the extremely short working distance of the probe shaft, highly reproducible results are achieved working with the probe tip immersed in liquids, slurries, powders, or in direct contact with solids.

The BAC101-SS-532 (785) model comes with a 316 stainless steel probe shaft, with a high-precision UV-grade sapphire lens affixed to the end of the shaft using a proprietary epoxy designed for chemical resistance and high temperatures. The BAC101-HS-532 (785) model has a high-performance Hastelloy C-276 shaft, with the sapphire optics affixed to the Hastelloy using gold-based compression sealing, providing an even wider temperature range with exceptional chemical resistance for more demanding environments.

The standard fiber comes at a length of 1.5m and includes flexible fiber coupling, internal support and a durable protective PVC jacket. The excitation fiber has a 105 μm core diameter and is FC/PC terminated. The collection fibers for the HT models have a 300 μm core collection fiber and are FC/PC terminated, while standard models have a 200 μm core and are SMA 905 terminated.

For unpressurized measurements requiring longer working distances, such as going through glass reactors, Kalrez O-ring sealed shafts RIS100-FS (fused silica window) and RIS100-SA (sapphire window) are available.

Features:

- State-of-the-art packaging
- Optimized optical design
- Increased durability for industrial applications
- High-throughput options
- Excellent long-term stability

Dimensions:

Probe (mm[in]):

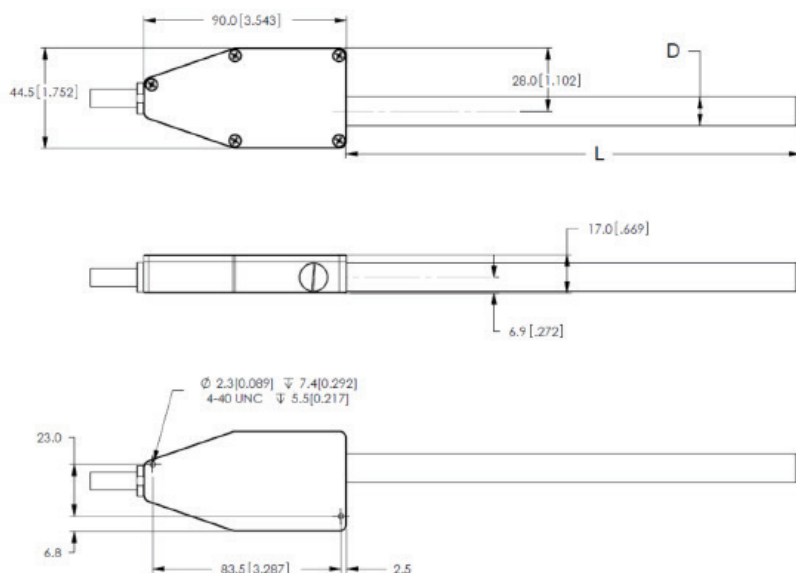

Specifications:

Model#	BAC101-SS-532/ BAC101-SS-785/ BAC101-SS-785-HT	BAC101-HS-532/ BAC101-HS-785
Excitation wavelength	532 nm or 785 nm	
Raman cut-off	150cm ⁻¹	
Rayleigh rejection	>>OD6	
Shaft material	316 SS	Hastelloy C-276
Shaft length	8" (203.2 mm)	
Shaft diameter	0.5" (12.7 mm)	
Shaft wall thickness	0.109" (3.27 mm)	0.065" (1.65 mm)
Working distance	0.5 mm in air, 0.8 mm in water	0.4 mm in air, 0.6
Probe shaft operating temperature*	-55 to 200°C	-100 to 300°C
Maximum probe body operating temperature*	80°C	
Humidity	Non-condensing	
Shaft window material	Epoxied sapphire ball lens (Kalrez-sealed fused silica, or sapphire options)	Gold sealed sapphire ball lens (Kalrez-sealed fused silica, or sapphire options)
Shaft seal pressure rating	4000 psi (275 bar)	
Shaft chemical compatibility	Suitable for continuous exposure to dilute and concentrated acids, bases and most organic solvents including ethanol, THF, ethyl acetate, acetone, DCM, toluene, pentane and acetonitrile	Suitable for continuous exposure to dilute and concentrated (hot and cold) acids, bases and organic solvents. Avoid prolonged exposure to aqua regia.
Fiber length	1.5 m in total; 1.0 m at common end and 0.5 m on each branch	
Excitation fiber	105 µm core; FC/PC terminated	
Collection fiber	200 µm core, SMA 905 terminated for standard models; 300 µm core, FC/PC terminated for HT models	

* The probe body and shaft are not sealed. To prevent irreversible damage caused by condensation on internal optic surfaces, do not subject any part of the probe to a temperature below the dew point. If needed, use a purged probe.