

BAC102 Raman Trigger Probe

Raman Accessory



The BAC102 Raman Trigger Probe offers a trigger function which is designed for versatility in making Raman measurements. The probe can be brought directly to the sample and make contact with either the sample or the packaging of the sample via a detachable distance regulator that ensures proper focusing while minimizing contamination to the lens material. The trigger button provides the convenience of initiating measurement from the probe head.

Different versions of the probe with varying optical lenses allow for measurements down to 65cm^{-1} Raman shift (100cm^{-1} for 1064 nm version). The standard fiber length of 1.5m includes flexible fiber coupling, internal support and durable protective PVC jacket. The excitation fiber has a $105\text{ }\mu\text{m}$ core diameter and is FC/PC terminated. The collection fibers for the high throughput models (HT) have a $300\text{ }\mu\text{m}$ core collection fiber and are FC/PC terminated, while standard models have a $200\text{ }\mu\text{m}$ core and are SMA 905 terminated.

The standard shaft is 304SS with a flat quartz window and spot size of $85\text{ }\mu\text{m}$. Custom probes can be constructed with dimensions, material and working distance to suit your application needs. For unpressurized immersion measurements, Kalrez O-ring sealed shafts RIS100-FS (fused silica window) and RIS100-SA (sapphire window) are available.

Features:

- State-of-the-art packaging
- Optimized optical design
- High throughput options
- Excellent long-term stability
- E-grade optional range down to 65 cm^{-1}

Dimensions:

Probe (mm[in]):

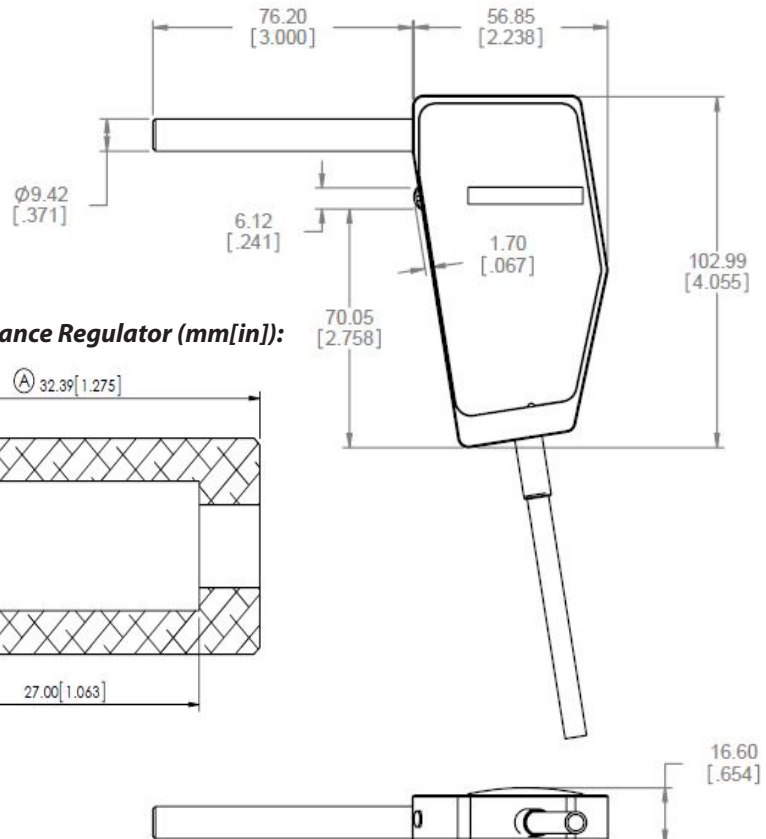

Specifications:

| | |
|--|---|
| Excitation wavelength | 532 nm, 785 nm or 1064 nm |
| Raman cut-off | 65 cm ⁻¹ for 532E, and 785E models* 150 cm ⁻¹ for 532, 532-HT, 785, and 785-HT models 100 cm ⁻¹ for 1064, and 1064-HT models |
| Rayleigh rejection | OD6 (OD8 optional) |
| Shaft material | 304 SS |
| Shaft length | 3" (76.2 mm) |
| Shaft diameter | 0.371" (9.42 mm) |
| Trigger switch | SMD light touch switch |
| Working distance ¹ | 5.4 mm for 532 nm models 5.5 mm for 785 nm models 5.9 mm for 1064 nm models |
| Laser spot diameter at focal plane | 85 μm |
| Maximum probe shaft operating temperature ² | Standard version: 80°C Immersion version : 150°C |
| Maximum probe body operating temperature ² | 80°C |
| Storage temperature ² | -10°C – 60°C |
| Humidity | 10-85%, non-condensing |
| Shaft window material | Flat quartz (Flat sapphire or sapphire ball optional) |
| Seal material (shaft tip) | Standard shafts: Epoxy sealed immersion shafts: Kalrez® O-ring or customer specified |
| Fiber length | 1.5 m |
| Excitation fiber | 105 μm core; FC/PC terminated |
| Collection fiber | 200 μm core, SMA 905 terminated for standard models; 300 μm core, FC/PC terminated for HT models. |

Notes:

- 1) Working distance is defined as the distance from the focal point in air to the end surface of the shaft.
- 2) The probe body and shaft are not sealed. To prevent irreversible damage caused by condensation on internal optic surfaces, do not subject any part of the probe to a temperature below the dew point. If needed, use a purged probe.

*cut-on start from 65 (up to 70) cm⁻¹