

# 930 Compact IC Flex



930 Compact IC Flex Oven/ChS/PP/Deg

## Manual

8.930.8016EN / v3 / 2023-12-31





Metrohm AG  
CH-9100 Herisau  
Switzerland  
Phone +41 71 353 85 85  
Fax +41 71 353 89 01  
info@metrohm.com  
www.metrohm.com

# **930 Compact IC Flex**

## **930 Compact IC Flex Oven/ChS/PP/Deg**

2.930.2360

## **Manual**

Technical Communication  
Metrohm AG  
CH-9100 Herisau  
techcom@metrohm.com

This documentation is protected by copyright. All rights reserved.

This documentation has been prepared with great care. However, errors can never be entirely ruled out. Please send comments regarding possible errors to the address above.

# Table of contents

<b>1</b>	<b>Introduction</b>	<b>1</b>
1.1	Instrument description .....	1
1.2	Intended use .....	3
1.3	Safety instructions .....	3
1.3.1	General notes on safety .....	3
1.3.2	Electrical safety .....	4
1.3.3	Tubing and capillary connections .....	5
1.3.4	Flammable solvents and chemicals .....	5
1.3.5	Recycling and disposal .....	5
1.4	Symbols and conventions .....	6
<b>2</b>	<b>Overview of the instrument</b>	<b>7</b>
2.1	Front .....	7
2.2	Rear .....	9
2.3	Feed-throughs for capillaries and cables .....	10
<b>3</b>	<b>Installation</b>	<b>14</b>
3.1	Setting up the instrument .....	14
3.1.1	Packaging .....	14
3.1.2	Checks .....	14
3.1.3	Location .....	14
3.2	Capillary connections in the IC system .....	14
3.3	Removing transport locking screws .....	17
3.4	Connecting the drainage tubing and leak sensor .....	18
3.4.1	Installing the drainage tubing .....	18
3.4.2	Connecting the leak sensor .....	20
3.5	Column oven .....	20
3.6	Connecting the eluent bottle .....	21
3.7	Connecting the eluent degasser .....	25
3.8	Installing the high-pressure pump .....	25
3.9	Installing an inline filter .....	26
3.10	Installing the pulsation absorber .....	27
3.11	Injection valve .....	28
3.12	Metrohm Suppressor Module (MSM) .....	30
3.12.1	Inserting the rotors .....	30
3.12.2	Connecting the Metrohm Suppressor Module (MSM) .....	33



<b>3.13</b>	<b>Peristaltic pump</b> .....	<b>38</b>
3.13.1	Installing the peristaltic pump .....	38
3.13.2	Mode of operation for the peristaltic pump .....	42
<b>3.14</b>	<b>Installing the conductivity detector</b> .....	<b>43</b>
<b>3.15</b>	<b>Installing the amperometric detector</b> .....	<b>44</b>
<b>3.16</b>	<b>Connecting the sample degasser (optional)</b> .....	<b>44</b>
<b>3.17</b>	<b>Connecting the instrument to a computer</b> .....	<b>46</b>
<b>3.18</b>	<b>Connecting the instrument to the power grid</b> .....	<b>47</b>
<b>3.19</b>	<b>Initial start-up</b> .....	<b>48</b>
<b>3.20</b>	<b>Connecting and rinsing the guard column</b> .....	<b>50</b>
<b>3.21</b>	<b>Connecting the separation column</b> .....	<b>52</b>
<b>3.22</b>	<b>Conditioning</b> .....	<b>56</b>
<b>4</b>	<b>Operation</b> .....	<b>58</b>
<b>5</b>	<b>Operation and maintenance</b> .....	<b>59</b>
<b>5.1</b>	<b>IC system</b> .....	<b>59</b>
5.1.1	Operation .....	59
5.1.2	Care .....	59
5.1.3	Maintenance by Metrohm Service .....	59
5.1.4	Shutting down and recommissioning .....	60
<b>5.2</b>	<b>Capillary connections</b> .....	<b>61</b>
<b>5.3</b>	<b>Servicing the door</b> .....	<b>61</b>
<b>5.4</b>	<b>Column oven – Replacing the capillaries</b> .....	<b>61</b>
<b>5.5</b>	<b>Handling the eluent</b> .....	<b>63</b>
5.5.1	Manufacturing eluent .....	63
5.5.2	Changing the eluent .....	64
<b>5.6</b>	<b>Servicing the eluent degasser</b> .....	<b>64</b>
<b>5.7</b>	<b>Notes on operating the high-pressure pump</b> .....	<b>65</b>
<b>5.8</b>	<b>Servicing the high-pressure pump</b> .....	<b>66</b>
<b>5.9</b>	<b>Servicing the inline filter</b> .....	<b>79</b>
<b>5.10</b>	<b>Servicing the pulsation absorber</b> .....	<b>82</b>
<b>5.11</b>	<b>Injection valve</b> .....	<b>82</b>
<b>5.12</b>	<b>Metrohm Suppressor Module (MSM)</b> .....	<b>82</b>
5.12.1	Notes for operating the Metrohm Suppressor Module (MSM) .....	82
5.12.2	Taking care of the suppressor housing .....	83
5.12.3	Servicing the Metrohm Suppressor Module (MSM) .....	83
<b>5.13</b>	<b>Peristaltic pump</b> .....	<b>91</b>
5.13.1	Notes on operating the peristaltic pump .....	91

5.13.2	Servicing the peristaltic pump .....	91
<b>5.14</b>	<b>  Servicing the detector .....</b>	<b>93</b>
<b>5.15</b>	<b>  Rinsing the sample path .....</b>	<b>93</b>
<b>5.16</b>	<b>  Separation column .....</b>	<b>95</b>
5.16.1	Separating efficiency .....	95
5.16.2	Protecting the separation column .....	95
5.16.3	Storing the separation column .....	95
5.16.4	Regenerating the separation column .....	95
<b>6</b>	<b>  Troubleshooting .....</b>	<b>97</b>
6.1	.....	97
<b>7</b>	<b>  Technical specifications .....</b>	<b>102</b>
7.1	Reference conditions .....	102
7.2	Ambient conditions .....	102
7.3	Housing .....	102
7.4	Weight .....	103
7.5	Leak sensor .....	103
7.6	Column oven .....	103
7.7	Eluent degasser .....	103
7.8	High-pressure pump .....	104
7.9	Injection valve .....	105
7.10	Metrohm Suppressor Module (MSM) .....	105
7.11	Peristaltic pump .....	105
7.12	Detector .....	105
7.13	Sample degasser .....	106
7.14	Energy supply .....	106
7.15	Interfaces .....	106
<b>8</b>	<b>  Accessories .....</b>	<b>107</b>
	<b>  Index .....</b>	<b>108</b>



## Table of figures

Figure 1	Front .....	7
Figure 2	Rear .....	9
Figure 3	Feed-throughs on the door .....	11
Figure 4	Openings for capillaries and cables .....	12
Figure 5	Ducts for capillaries .....	13
Figure 6	Removing the transport locking screws .....	17
Figure 7	Installing the eluent bottle cap .....	21
Figure 8	Installing the tubing weighting and aspiration filter .....	23
Figure 9	High-pressure pump with purge valve .....	26
Figure 10	Inline filter .....	27
Figure 11	Pulsation absorber .....	27
Figure 12	Exchanging the sample loop .....	29
Figure 13	Metrohm Suppressor Module (MSM) – Connection capillaries .....	33
Figure 14	Peristaltic pump .....	42
Figure 15	Column oven .....	62
Figure 16	High-pressure pump – Parts .....	66
Figure 17	High-pressure pump – Cross-section .....	73
Figure 18	Tool for piston seal (6.2617.010) .....	74
Figure 19	Removing the piston cartridge from the pump head .....	74
Figure 20	Inserting the piston seal into the tool .....	75
Figure 21	Parts of the piston cartridge .....	76
Figure 22	Inline filter – Removing the filter .....	80
Figure 23	Parts of the Metrohm Suppressor Module (MSM) .....	83
Figure 24	Pump tubing connection – Replacing the filter .....	92

# 1 Introduction

## 1.1 Instrument description

The 930 Compact IC Flex is a robust ion chromatograph. It is distinguished by:

- Its intelligence: All of the functions are monitored, optimized and documented in an FDA-compatible manner. Intelligent components, such as iColumns, save important data onto a chip.
- Its compact design: It has a small footprint.
- Its transparency: All components are easily accessible and located for simple visibility and can be monitored during operation through a large window.
- Its safety: The wet end and the electronics are physically separated, thereby preventing fluids from coming into contact with the electronics to a large extent. A leak sensor is integrated into the wet end.
- Its environmental compatibility.
- Its low noise emission.
- The intelligent MagIC Net software.

The 930 Compact IC Flex is operated using the MagIC Net software. A USB cable is used to connect the instrument to a computer with MagIC Net installed. The intelligent software detects the instrument automatically and checks its functionality. The software controls and monitors the instrument, evaluates the measured data and manages it in a database.

The 930 Compact IC Flex Oven/ChS/PP/Deg consists of the following modules:

### Housing

The sturdy housing contains the instrument's electronic components, including their interfaces and one connector for a separation column. In addition, the housing provides space for a conductivity detector or an amperometric detector. Capillaries and cables can be fed into and out of the instrument through several openings.

### Leak sensor

The leak sensor detects leaking liquid that collects in the instrument's base tray. Liquid that leaks in the instrument is routed to the base tray using drainage tubing and detected there.

**Column oven**

The column oven regulates the temperature for the separation column and the eluent, thereby providing stable measuring conditions. There is a column holder with chip reader in the column oven.

**Eluent degasser**

The eluent degasser removes gas bubbles and dissolved gases from the eluent.

**High-pressure pump**

The intelligent and low-pulsation high-pressure pump pumps the eluent through the IC system. It is equipped with a chip where its technical specifications and "life history" (operating hours, service data, etc.) are stored.

**Inline filter**

Inline filters protect the separation column reliably from potential contamination from the eluent. The filter pads with 2 µm pore size can be replaced quickly and easily. They remove particles from the solutions, such as bacteria and algae.

**Pulsation absorber**

The pulsation absorber protects the separation column from damage caused by pressure fluctuations, e.g. when the injection valve is switched, and reduces interfering pulsations during highly sensitive measurements.

**Injection valve**

The injection valve connects the eluent path to the sample path. By a quick and precise switching of the valve, a quantity of sample solution defined by the size of the sample loop is injected and flushed to the separation column with the eluent.

**Metrohm Suppressor Module (MSM)**

The chemical suppressor MSM consists of the suppressor drive, a rotor and, where applicable, an adapter. The suppressor drive gives you the flexibility to use different rotors according to the principle "one drive – many rotors". Suppression rotors with different capacities and construction or a rotor for sample preparation (SPM Rotor) are readily interchangeable with appropriate adapters as needed. The rotors are not included in the instrument's scope of delivery. The rotor required for the application and any adapter that is required must be ordered separately.

**Peristaltic pump**

The peristaltic pump is used for pumping sample and auxiliary solutions. It can rotate in both directions.

### **Detector**

Metrohm offers a series of different detectors for various analysis tasks. A suitable detector type must be ordered as a separate device.

### **Sample degasser**

The sample degasser removes gas bubbles and dissolved gases from the sample.

### **Separation column**

The intelligent separation column separates different components according to their interactions with the column. Metrohm separation columns are equipped with a chip where their technical specifications and history (start-up, operating hours, injections etc) are stored.

## **1.2 Intended use**

The 930 Compact IC Flex Oven/ChS/PP/Deg is used for the determination of anions or polar substances with chemical suppression using ion chromatography.

It can also be used as needed for the determination of cations, polar substances or anions without chemical suppression.

This instrument is suitable for processing chemicals and flammable samples. Therefore, the use of the 930 Compact IC Flex requires the user to have basic knowledge and experience in handling toxic and caustic substances. Knowledge regarding the application of fire prevention measures prescribed for laboratories is also mandatory.

## **1.3 Safety instructions**

### **1.3.1 General notes on safety**



#### **WARNING**

Operate this instrument only according to the information contained in this documentation.

This instrument left the factory in a flawless state in terms of technical safety. To maintain this state and ensure non-hazardous operation of the instrument, the following instructions must be observed carefully.



### 1.3.3 Tubing and capillary connections



#### CAUTION

Leaks in tubing and capillary connections are a safety risk. Tighten all connections well by hand. Avoid applying excessive force to tubing connections. Damaged tubing ends lead to leakage. Appropriate tools can be used to loosen connections.

Check the connections regularly for leakage. If the instrument is used mainly in unattended operation, then weekly inspections are mandatory.

### 1.3.4 Flammable solvents and chemicals



#### WARNING

All relevant safety measures are to be observed when working with flammable solvents and chemicals.

- Set up the instrument in a well-ventilated location (e.g. fume cupboard).
- Keep all sources of flame far from the workplace.
- Clean up spilled liquids and solids immediately.
- Follow the safety instructions of the chemical manufacturer.



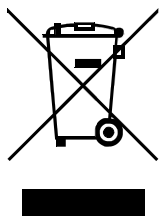



### 1.3.5 Recycling and disposal



Properly dispose of chemicals and of the product to reduce negative effects on the environment and public health. Local authorities, waste disposal companies or dealers provide more detailed information on disposal. Observe the WEEE EU directive (WEEE = Waste Electrical and Electronic Equipment) for the proper disposal of waste electronic equipment within the European Union.

## 1.4 Symbols and conventions

The following symbols and formatting may appear in this documentation:

<i>(5-12)</i>	<b>Cross-reference to figure legend</b> The first number refers to the figure number, the second to the instrument part in the figure.
<b>1</b>	<b>Instruction step</b> Carry out these steps in the sequence shown.
<b>Method</b>	<b>Dialog text, parameter</b> in the software
<b>File ► New</b>	Menu or menu item
<b>[Next]</b>	<b>Button</b> or <b>key</b>
	<b>WARNING</b> This symbol draws attention to a possible life-threatening hazard or risk of injury.
	<b>WARNING</b> This symbol draws attention to a possible hazard due to electrical current.
	<b>WARNING</b> This symbol draws attention to a possible hazard due to heat or hot instrument parts.
	<b>WARNING</b> This symbol draws attention to a possible biological hazard.
	<b>CAUTION</b> This symbol draws attention to possible damage to instruments or instrument parts.
	<b>NOTE</b> This symbol highlights additional information and tips.

## 2 Overview of the instrument

### 2.1 Front

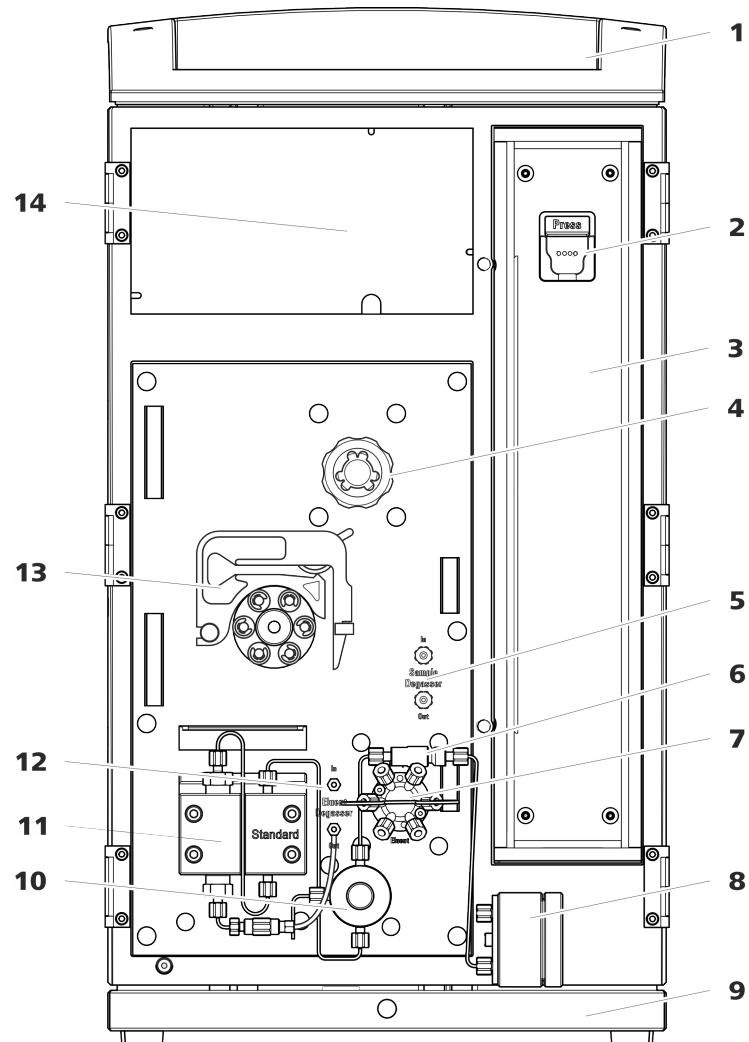

Figure 1 Front

<b>1</b>	<b>Bottle holder</b> Offers space for the eluent bottle and additional accessories.	<b>2</b>	<b>Column holder</b> For hanging the separation column (iColumn). With column recognition.
<b>3</b>	<b>Column oven</b>	<b>4</b>	<b>Metrohm Suppressor Module (MSM)</b>
<b>5</b>	<b>Sample degasser</b>	<b>6</b>	<b>Inline filter</b>
<b>7</b>	<b>Injection valve</b>	<b>8</b>	<b>Pulsation absorber</b>



**9 Base tray**

With leak sensor.

**11 High-pressure pump**

Pumps the eluent through the IC system.

**13 Peristaltic pump**

**10 Purge valve**

For deaerating the high-pressure pump.  
With rotary knob in the center and pressure sensor.

**12 Eluent degasser**

**14 Detector chamber**

Offers space for an embedded detector and additional accessories.

## 2.2 Rear

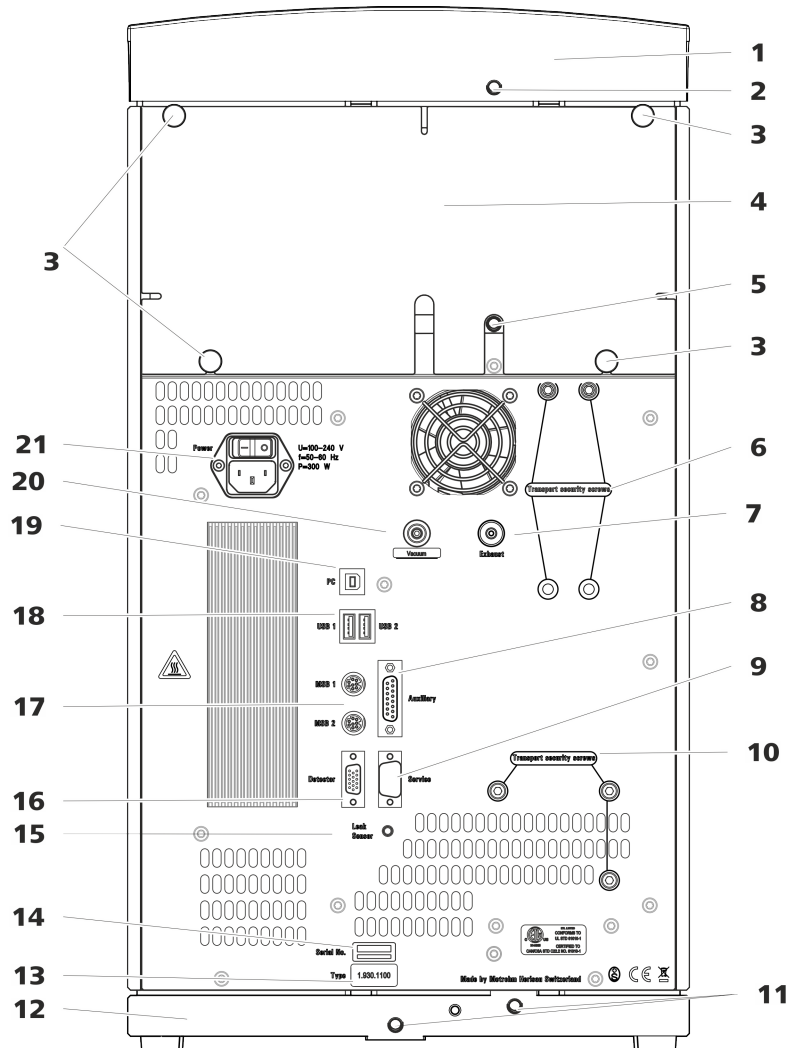

Figure 2 Rear

<p><b>1 Bottle holder</b></p>	<p><b>2 Drainage tubing connection</b> For connecting the drainage tubing, which guides escaped fluids away from the bottle holder.</p>
<p><b>3 Knurled screws</b> For fastening the removable back panel.</p>	<p><b>4 Back panel</b> Removable. Enables access to the detector chamber.</p>
<p><b>5 Drainage tubing connection</b> For connecting the drainage tubing, which guides escaped liquids away from the detector chamber.</p>	<p><b>6 Transport locking screws</b> For securing the vacuum pump when transporting the instrument.</p>



<p><b>7 Exhaust opening</b> Labeled <i>Exhaust</i>. For extracting the air from the vacuum chamber.</p>	<p><b>8 Auxiliary connection socket</b> For connecting an 891 Professional Analog Out (2.891.0010).</p>
<p><b>9 Service connection socket</b> For Metrohm service only.</p>	<p><b>10 Transport locking screws</b> For securing the high-pressure pump when transporting the instrument.</p>
<p><b>11 Drainage tubing connections</b> For connecting two drainage tubings that guide the escaped fluid to the leak sensor and from there to the waste container.</p>	<p><b>12 Base tray</b> With leak sensor.</p>
<p><b>13 Type plate</b></p>	<p><b>14 Serial number</b></p>
<p><b>15 Leak sensor connection socket</b> Labeled <i>Leak Sensor</i>. For connecting the leak sensor connection cable.</p>	<p><b>16 Detector connection socket</b> Labeled <i>Detector</i>. For connecting Metrohm detectors.</p>
<p><b>17 MSB connection sockets</b> Labeled <i>MSB 1</i> and <i>MSB 2</i>. For connecting MSB devices.</p>	<p><b>18 USB connection sockets</b> Labeled <i>USB 1</i> and <i>USB 2</i>. For connecting USB devices.</p>
<p><b>19 PC connection socket</b> For connecting the instrument to the computer with the USB cable (6.2151.020).</p>	<p><b>20 Vacuum connection</b> Plugged with a stopper.</p>
<p><b>21 Power socket</b> Power socket for connecting the power cable and power switch for switching the instrument on and off.</p>	

## 2.3 Feed-throughs for capillaries and cables

Multiple openings are available for leading capillaries into the instrument and for leading capillaries and cables out of the instrument:

- Openings on the door
- Openings on the back panel
- Ducts between the instrument and the base tray as well as between the instrument and the bottle holder (*see figure 5, page 13*)

## Openings on the door

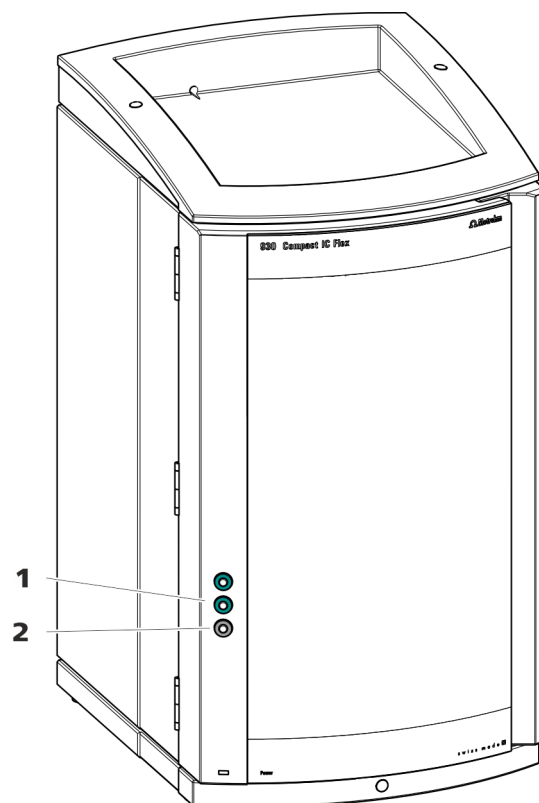

Figure 3 Feed-throughs on the door

### 1 Luer connector

For connecting a capillary from inside and for inserting a syringe (6.2816.020) from outside. For manual sample injection.

### 2 Opening for capillaries

For up to 3 capillaries.

An opening for up to 3 capillaries is located on the door of the instrument.

The two Luer connections above are not actually openings; the capillaries are fastened to the Luer connection from within using PEEK pressure screws. You can use a syringe to inject or draw out liquid from the outside.



### Openings on the back panel

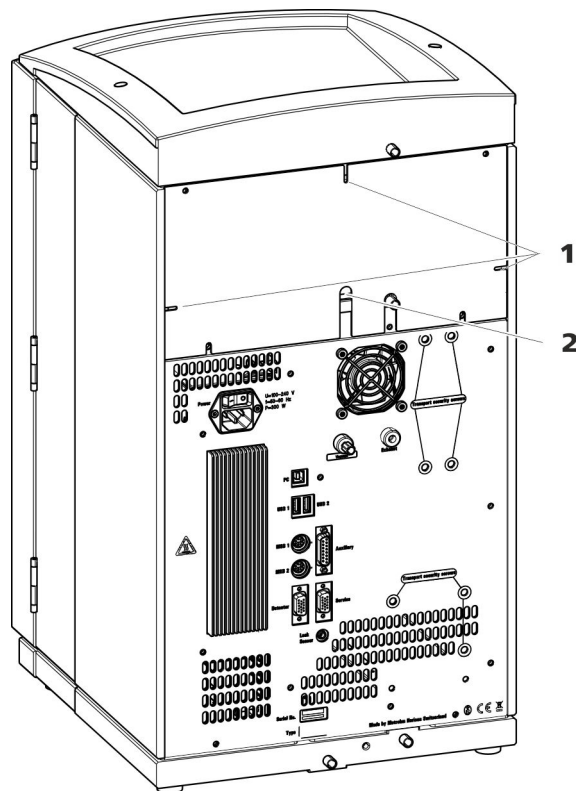

Figure 4 Openings for capillaries and cables

#### 1 Openings for capillaries

#### 2 Openings for cables

The removable back panel is outfitted with openings through which capillaries and cables can be lead out of the detector chamber.

### Ducts for capillaries

There are ducts for capillaries between the instrument and base tray as well as between the instrument and the bottle holder. The capillaries can be fed to the front of the instrument from both sides of the instrument and from the front of the instrument to the back of the instrument.

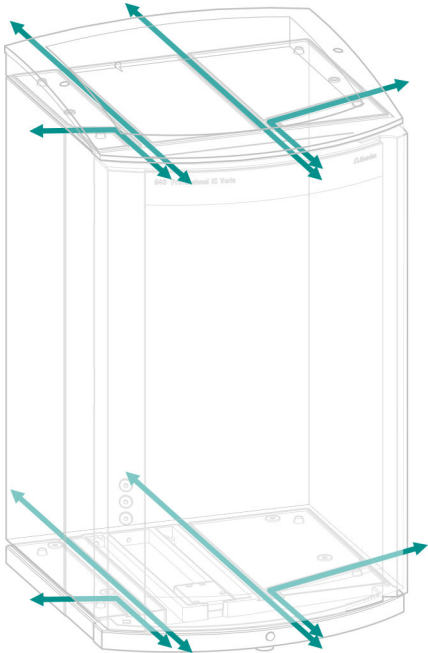

Figure 5 Ducts for capillaries



Also see: *PEEK pressure screws 1x1* video on the Internet <http://ic-help.metrohm.com>.

### Connection capillaries

PEEK capillaries and PTFE capillaries are used in the IC system.

*PEEK capillaries (polyetheretherketone)*

PEEK capillaries are pressure-stable up to 400 bar (depending on the inner diameter), flexible, chemically inert and have an extremely smooth surface. They can be readily cut down to the desired length with the capillary cutter (6.2621.080).

Use:

- PEEK capillaries with an inner diameter of 0.25 mm (6.1831.010) for the entire high-pressure section.
- PEEK capillaries with an inner diameter of 0.5 mm (6.1831.180) for the sample path.

*PTFE capillaries (poly(tetrafluoroethylene))*

PTFE capillaries are transparent and enable visual tracing of the liquids to be pumped. They are chemically inert, flexible and temperature-resistant up to 80 °C. They can be readily cut down to the desired length with the capillary cutter (6.2621.080).

Use:

PTFE capillaries (6.1803.0x0) are used for the low-pressure section.

- PTFE capillaries with an inner diameter of 0.5 mm for sample processing and for the transfer of rinsing solutions (they are not necessarily included in the scope of delivery of the instrument).

### Capillary connections



#### NOTE

#### Sprays of chemicals caused by capillaries slipping out

If you work with an increased system pressure (> 15 MPa), capillaries may slip out of the pressure screws. This can lead to sprays of chemicals.

To avoid this, we recommend

- degreasing the ends of the capillaries before installing them. Dampen a cloth with acetone and wipe off the ends of the capillaries before connecting them with the pressure screws.
- tightening the pressure screws firmly using a wrench (6.2739.000).

In order to achieve optimum analysis results, capillary connections in an IC system must be absolutely tight and free of dead volume. Dead volume



occurs if two capillary ends connected to each other do not fit exactly, thus allowing liquid to escape. There are two possible causes for this:

- The capillary ends do not have exactly flat edges.
- The two capillary ends do not completely meet.

One prerequisite for dead-volume-free capillary connection is that both capillary ends are cut exactly flat. Therefore we recommend cutting PEEK capillaries only with a capillary cutter (6.2621.080).

Also see: *Cutting capillaries* video on the Internet <http://ic-help.metrohm.com>.

### Creating dead-volume-free capillary connections

To create dead-volume-free capillary connections, proceed as follows:

- 1** Wipe off the end of the capillary with a cloth dampened with acetone.
- 2** Slide the pressure screw over the capillary. Ensure that the capillary protrudes 1 to 2 mm from the tip of the pressure screw.
- 3** Push the capillary into the connection or coupling as far as it will go and hold it there.
- 4** Only then start turning the pressure screw. Hold the capillary in the stop position while turning it shut.

### Colored sleeves for PEEK capillaries

The enclosed set of varicolored sleeves for PEEK capillaries (6.2251.000) serves to easily differentiate the various flows of liquid in the system through color coding. Each capillary conveying a given liquid (e.g. eluent) can be marked with sleeves of the same color.

- 1** Slide a colored sleeve of a selected color over a capillary and move it to an easily visible position.
- 2** Heat the colored sleeve, e.g. with a hairdryer.

The colored sleeve shrinks and adapts to the shape of the capillary.



#### NOTE

In order to arrange capillaries more clearly, they can be bundled with the spiral band (6.1815.010).

### 3.3 Removing transport locking screws

To avoid damage to the drives for the high-pressure pump and the vacuum pump during transport, the pumps are secured with transport locking screws. These are located at the rear of the instrument and labeled with **Transport security screws**.

Remove these transport locking screws before the initial start-up.

#### Accessories

For this step you need:

- 4 mm hex key (6.2621.030)

#### Removing the transport locking screws

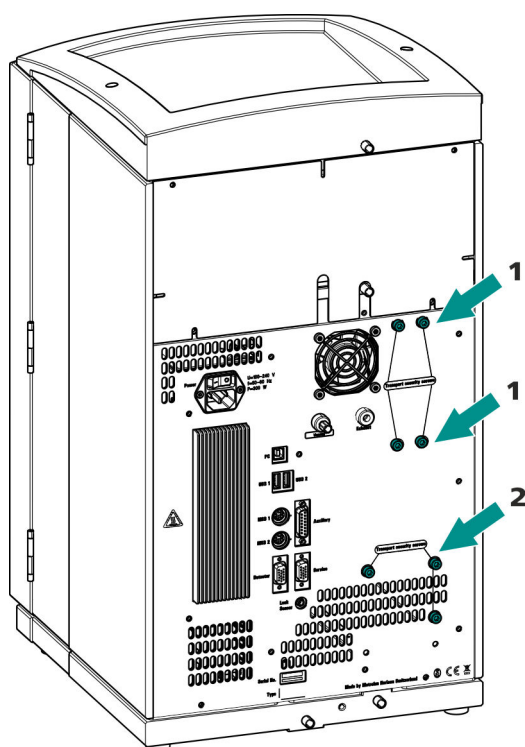

Figure 6 Removing the transport locking screws

#### 1 Transport locking screws

For the vacuum pump. Only present if the instrument has a degasser or a CO<sub>2</sub> Suppressor (MCS).

#### 2 Transport locking screws

For the high-pressure pump.

- 1 Remove all of the transport locking screws with the hex key.



Store the transport locking screws in a safe place. Reinsert the transport locking screws each time you transport the instrument a significant distance.



#### CAUTION

The pumps may be damaged if you transport the instrument without inserting the transport locking screws.

## 3.4 Connecting the drainage tubing and leak sensor

The leak sensor detects leaking liquid that collects in the instrument's base tray. Liquid that leaks in the bottle holder or in the detector chamber is conveyed to the base tray using drainage tubing and is detected there.

If the leak sensor detects a leak in the IC system, the IC instrument is switched off. The software displays a warning.

The leak sensor functions properly only if the following preconditions are met:

- The drainage tubing is connected.
- The leak sensor connection cable is inserted into the leak sensor connection socket.
- The 930 Compact IC Flex is switched on.
- The leak sensor is switched to **active** in the software.

### 3.4.1 Installing the drainage tubing

Liquid that leaks in the bottle holder or detector chamber flows to the rear of the instrument. Openings on the bottle holder and in the detector chamber allow the liquid to drain. The drainage tubing has to be mounted at these openings. This drainage tubing guides the leaking liquid to the base tray where the leak sensor is located.

#### *Accessories*

For this step you need the following parts from the accessory kit: Vario/Flex Basic (6.5000.000):

- 2 × silicone tubing (6.1816.020)
- Y connector (6.1807.010)

You also need scissors.

### Connecting the drainage tubing

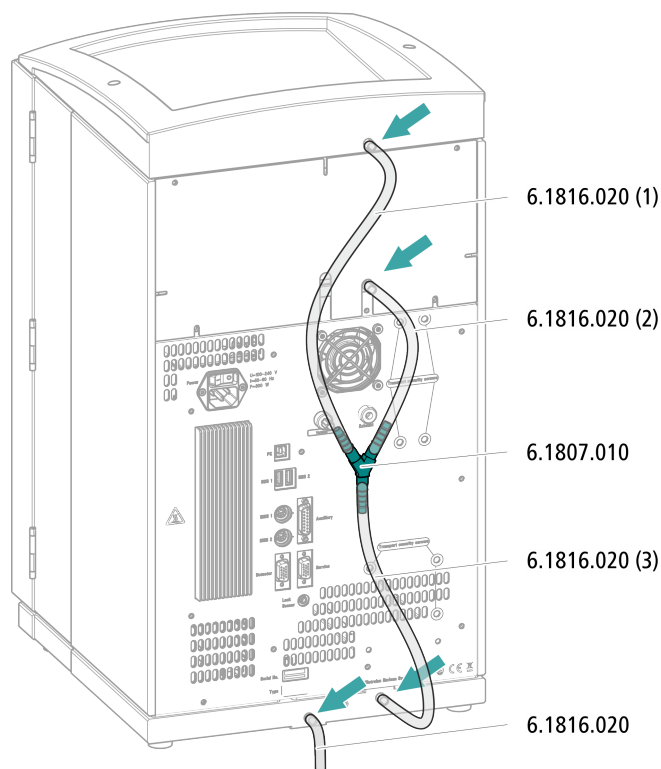

- 1** Cut a piece of silicone tubing into three pieces using scissors: 2 × approx. 40 cm and 1 × 20 cm.
- 2** Attach one end of the 40 cm long piece to the drainage tubing connection on the bottle holder.
- 3** Attach one end of the 20 cm long piece to the drainage tubing connection on the detector chamber.
- 4** Attach each of the loose ends of both pieces of silicone tubing to one end of the Y connector.
- 5** Attach one end of the second 40 cm long piece to the third end of the Y connector.  
Attach the loose end to the right-side drainage tubing connection on the base tray.
- 6** Attach one end of the second piece of silicone tubing to the left-side drainage tubing connection on the base tray.



Route the loose end into a waste container.

### 3.4.2 Connecting the leak sensor

#### Plugging in the leak sensor connection cable

The leak sensor connection cable is coiled up in the base tray.

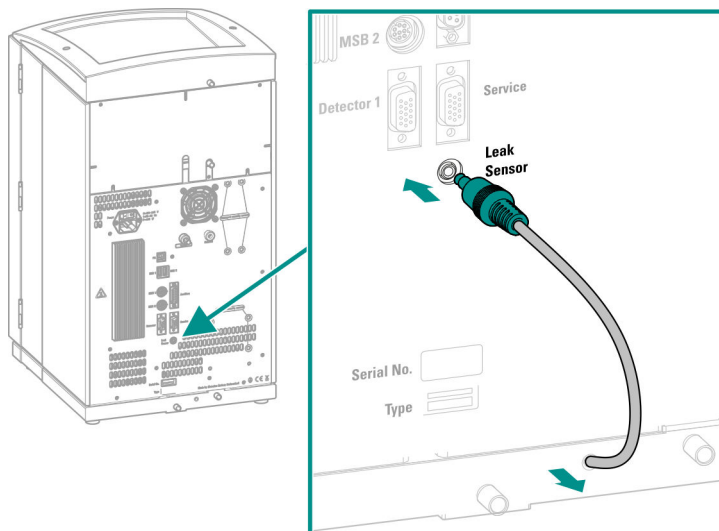

- 1 Pull the leak sensor connection cable out of the base tray as far as needed.
- 2 Plug the plug for the leak sensor connection cable into the leak sensor connection socket (labeled **Leak Sensor**).

## 3.5 Column oven

The column oven ensures that the separation takes place at a constant temperature. It is firmly sealed by the instrument's smaller door and is well insulated. The capillaries are fed through openings on the edge of the column oven, so that they do not get pinched when the door is closed. The temperature of the column oven can be configured in the software.

The column oven is completely connected. No installation work is required.

## 3.6 Connecting the eluent bottle

The eluent is aspirated out of the eluent bottle via the eluent aspiration tubing. The eluent aspiration tubing is installed on the entry to the eluent degasser.

The tubing must be fed out of the instrument through a suitable opening (see "Openings on the back panel", page 12) before the loose end can be connected to the eluent bottle.

### Accessories

For this step, you need the following accessories:

These parts are part of the *Vario/Flex ONE* accessory kit (6.5000.010).

- Eluent bottle (6.1608.070)
- The *eluent bottle cap GL 45* accessory set (6.1602.160)  
This accessory set contains the bottle cap, an M6 tubing nipple, an M8 tubing nipple, two O-rings and an M6 and M8 threaded stopper.
- The *tubing adapter for aspiration filter* accessory set (6.2744.210)  
This accessory set contains a filter holder, a clamping screw and tubing weighting.
- An aspiration filter (6.2821.090)
- The adsorber tube (6.1609.000)
- The SGJ clip (6.2023.020)

### Connecting the eluent aspiration tubing

#### 1 Installing the eluent bottle cap (6.1602.160)

- Start by pushing the M8 tubing nipple onto the loose end of the eluent aspiration tubing, followed by the O-ring.
- Push the loose end of the eluent aspiration tubing through the M8 opening of the bottle cap and screw it on for the time being.

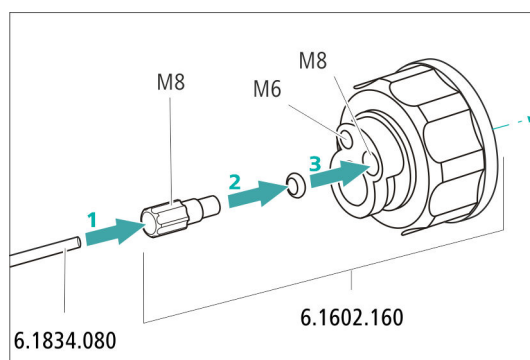

Figure 7 Installing the eluent bottle cap



## 2 Mounting the tubing adapter

Install the parts of the *tubing adapter for aspiration filter* (6.2744.210) accessory set:

- Start by pushing the tubing weighting onto the loose end of the eluent aspiration tubing.
- Then push the clamping screw onto the loose end of the eluent aspiration tubing.
- Lastly, push the filter holder onto the loose end of the eluent aspiration tubing and screw it onto the tubing nipple. The end of the tubing should extend approximately 1 cm.

## 3 Pre-rinsing the aspiration filter



### NOTE

Always wear gloves when handling the aspiration filter.

In order to avoid air bubbles after the installation of the aspiration filter, we recommend pre-rinsing the aspiration filter with ultrapure water or eluent.

For pre-rinsing, you will need the adapter Luer inner, M6 outer (6.02744.050), a syringe and a vessel with ultrapure water or eluent.

- Screw the adapter to the aspiration filter.
- Insert the syringe into the adapter.

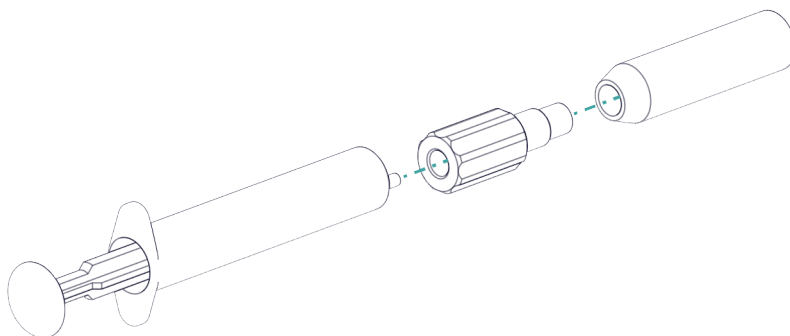

- Immerse the aspiration filter tin a vessel with ultrapure water or eluent.
- Fill the syringe completely with ultrapure water or eluent 3 times and then empty it again each time.

#### 4 Mounting the aspiration filter



##### NOTE

Always wear gloves when handling the aspiration filter.

- Place the loose end of the eluent aspiration tubing into the aspiration filter. The end of the tubing should reach approximately to the center of the aspiration filter.
- Tighten the aspiration filter to the filter holder.

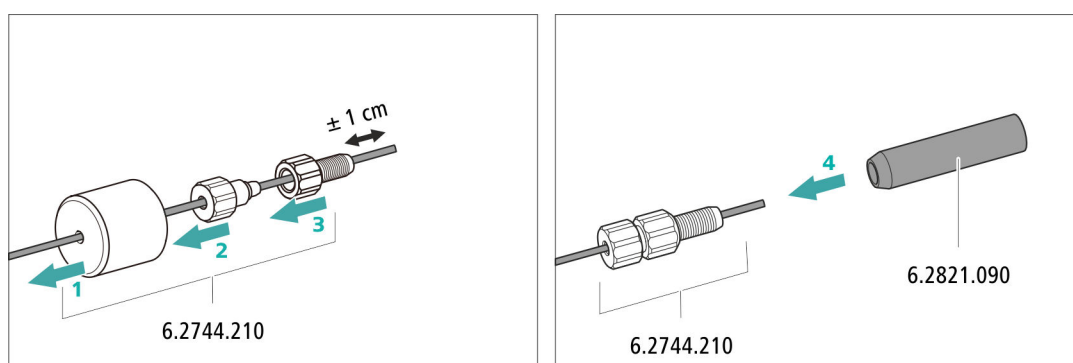
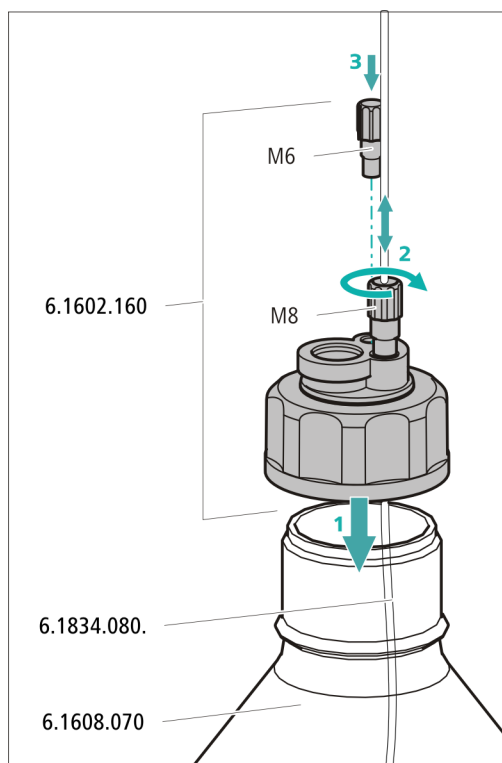

Figure 8 Installing the tubing weighting and aspiration filter

#### 5 Installing the eluent bottle cap on the eluent bottle

- Insert the eluent aspiration tubing into the eluent bottle (6.1608.070).
- Tighten the bottle cap on the eluent bottle.
- Adjust the length of the eluent aspiration tubing so that the aspiration filter is at the bottom of the eluent bottle. Then fix it in place using the M8 tubing nipple.
- Seal the M6 opening on the bottle cap with the M6 threaded stopper from the accessory set.



## 6 Mounting the adsorber tube



### NOTE

Depending on the eluent used, the adsorber tube (6.1609.000) must be filled differently:

- For alkaline eluents or eluents with a low buffer capacity: first a little cotton, then with CO<sub>2</sub> adsorber material.
  - For all other eluents: only with cotton.
- Remove the plastic cover from the large opening of the adsorber tube. Fill the adsorber tube and close it again using the plastic cover.
  - Insert the adsorber tube into the bottle cap's large opening. Fasten it to the bottle cap using the ground-joint clip (6.2023.020).

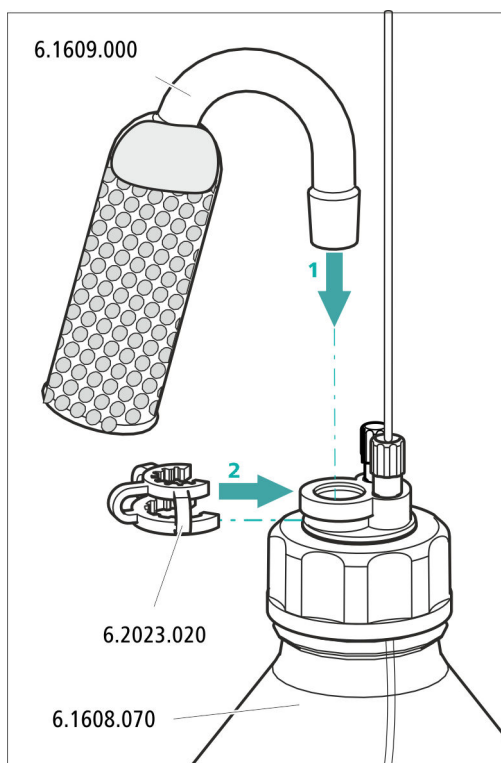

### 3.7 Connecting the eluent degasser

The high-pressure pump cannot generate uniform flow if the eluent contains small gas bubbles or dissolved gas. As a result, the baseline cannot be stabilized correctly. In order to achieve good measurement results, the eluent has to be degassed before it goes into the high-pressure pump.

The eluent degasser is completely connected. No installation work is required.

### 3.8 Installing the high-pressure pump

The intelligent and low-pulsation high-pressure pump pumps the eluent through the system. It is equipped with a chip where its technical specifications and "life history" (operating hours, service data, etc.) are saved.

The high-pressure pump consists of:

- The pump head, which pumps the eluent through the system.
- The purge valve used for bleeding the pump head.

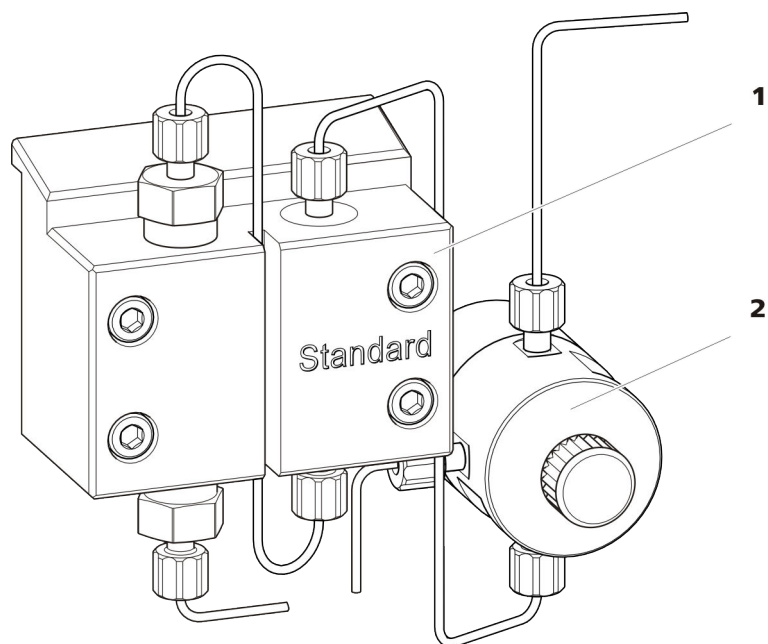

Figure 9 High-pressure pump with purge valve

**1** Pump head

**2** Purge valve

The high-pressure pump is completely connected. No installation work is required.

### 3.9 Installing an inline filter

Inline filters protect the separation column reliably from potential contamination from the eluent. The small filter pads with 2 µm pore size can be replaced quickly and easily. They remove particles from the solutions.

An inline filter (6.2821.120) is installed between the purge valve and the pulsation absorber as protection against particles.

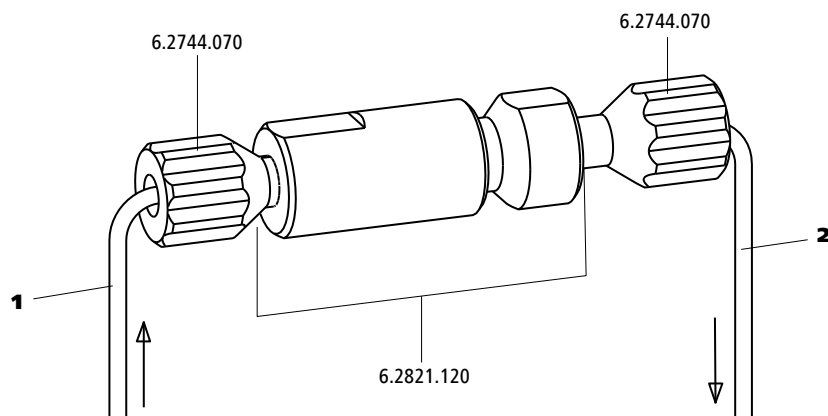

Figure 10 In-line filter

**1 Inlet capillary**

Connected to the purge valve.

**2 Outlet capillary**

Connected to the pulsation absorber.

The inline filter is completely connected. No installation work is required.

### 3.10 Installing the pulsation absorber

The pulsation absorber is installed between the high-pressure pump and the injection valve. It protects the separation column from damage caused by pressure fluctuations, e.g. when the injection valve is switched, and reduces interfering pulsations during highly sensitive measurements.

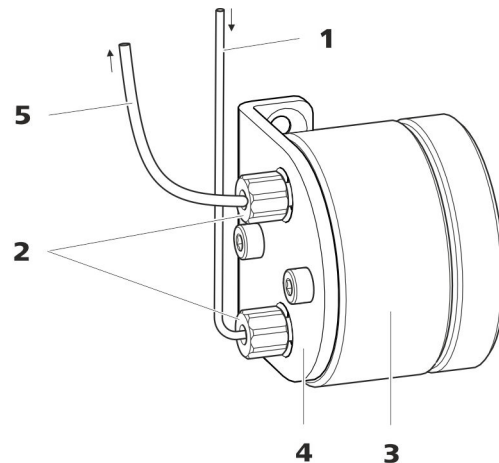

Figure 11 Pulsation absorber

**1 Connection capillary**

Connection to inline filter.

**2 PEEK pressure screws, short (6.2744.070)****3 Pulsation absorber (6.2620.150)****4 Holder for pulsation absorber****5 Connection capillary**

Connection to injection valve.

The pulsation absorber is completely connected. No installation work is required.

## 3.11 Injection valve

The injection valve connects the eluent path to the sample path. By a quick and precise switching of the valve a defined quantity of sample solution is injected and flushed to the separation column with the eluent.

The quantity of sample solution injected is determined by:

- the volume of the sample loop or
- by an 800 Dosino when the Metrohm intelligent Partial Loop Injection Technique (MiPT) is used.

The choice of sample loop depends on the application. The following sample loops are normally used:

Table 1 Which sample loop do I need?

Application	Sample loop
Cation determination	20 µL
Anion determination with suppression	20 µL
Anion determination without suppression	100 µL
MiPT	250 µL

The injection valve is completely connected. No installation work is required.

### Optional: Exchanging the sample loop

The sample loop can be replaced to match the application (*see table 1, page 28*).



#### NOTE

Only use PEEK pressure screws (6.2744.010) to connect capillaries and the sample loop to the injection valve.

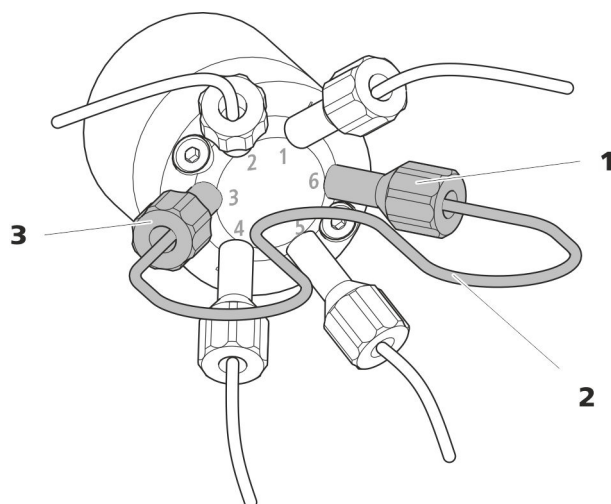

Figure 12 Exchanging the sample loop

**1 Pressure screw**  
Fastened to Port 6.

**2 Sample loop**

**3 Pressure screw**  
Fastened to Port 3.

### Exchanging the sample loop



#### NOTE

Observe a dead-volume-free installation of the sample loop (see "Creating dead-volume-free capillary connections", page 16).

#### 1 Removing the existing sample loop

- Loosen the pressure screws (6.2744.010) at Port 3 and Port 6.
- Remove the sample loop.

#### 2 Installing a new sample loop

- Fasten one end of the sample loop to Port 3 using a PEEK pressure screw (6.2744.010).
- Use the second PEEK pressure screw (6.2744.010) to fasten the other end of the sample loop to Port 6.





### CAUTION

The rotor may be destroyed during start-up if not inserted correctly. Therefore, follow the following instructions exactly.

### Inserting large rotors

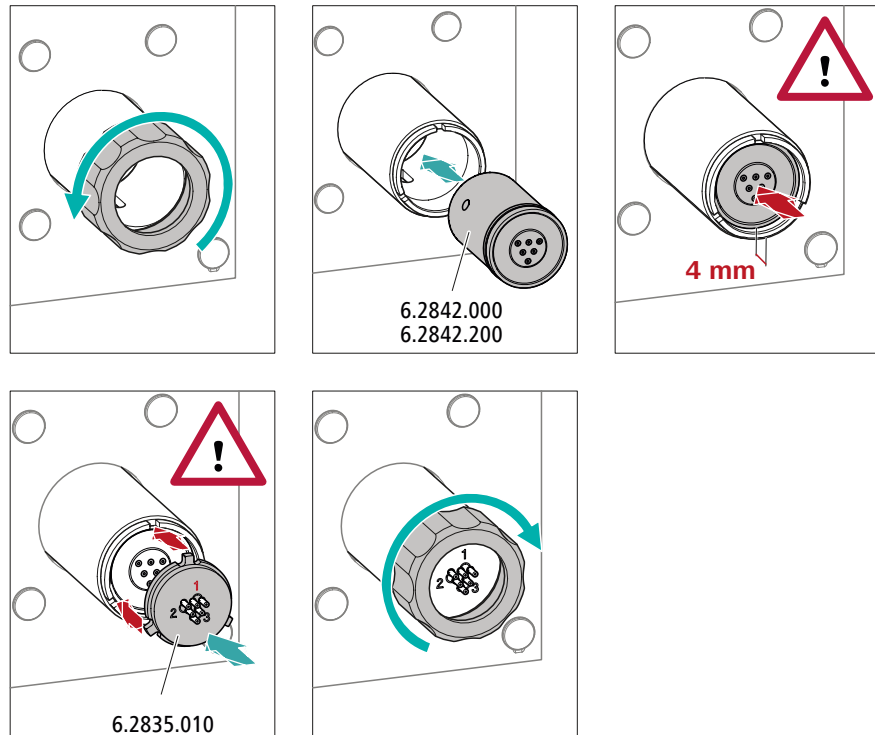

#### 1 Removing the union nut

Loosen the union nut and remove it.

#### 2 Inserting the rotor

- Clean the sealing surface of the rotor with ethanol using a lint-free cloth.
- Insert the rotor into the suppressor drive so that the tubing connections on the rear of the rotor fit into the corresponding recesses inside the suppressor drive and one of the three holes of the rotor is visible from below in the slot of the suppressor drive.

**NOTE**

The rotor's sealing surface is located approx. 4 mm deep inside the suppressor drive if the rotor is inserted correctly.

If this is not the case, then the rotor must be moved into the correct position using careful turning. If the rotor cannot be turned or removed, it can be moved into the correct position from below by means of a pointed object (e.g. a screwdriver).

**3 Inserting the connecting piece**

- Clean the sealing surface of the connecting piece with ethanol using a lint-free cloth.
- Insert the connecting piece into the suppressor drive so that connector 1 is on top and the three pins of the connecting piece fit into the corresponding recesses on the suppressor drive.

**4 Attaching the union nut**

Tighten the union nut on the thread of the suppressor drive by hand (do not use any tools).

**Inserting small rotors**

You need the adapter (6.2842.020) in order to insert a small rotor into the suppressor drive.

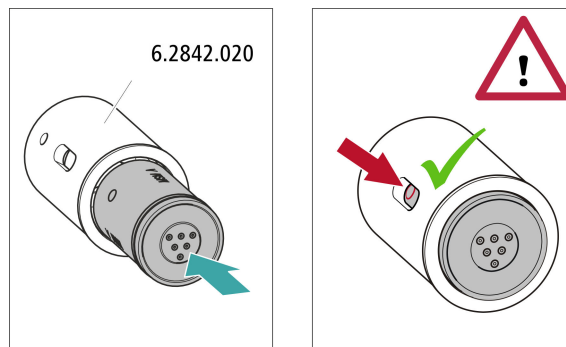
**1 Inserting the rotor into the adapter****CAUTION**

An incorrectly inserted rotor may be **destroyed** during start-up.

- Clean the sealing surface of the rotor with ethanol using a lint-free cloth.
- Insert the rotor into the adapter so that the tubing connections on the rear of the rotor fit into the corresponding recesses inside the adapter and one of the three holes of the rotor is visible in the slot of the adapter.

## 2 Inserting the adapter

Insert the adapter into the suppressor drive just like a large rotor (see "Inserting large rotors", page 31).

### 3.12.2 Connecting the Metrohm Suppressor Module (MSM)

The three entries and exits of the suppressor units, numbered 1, 2 and 3 on the connecting piece, each have two permanently installed PTFE capillaries.

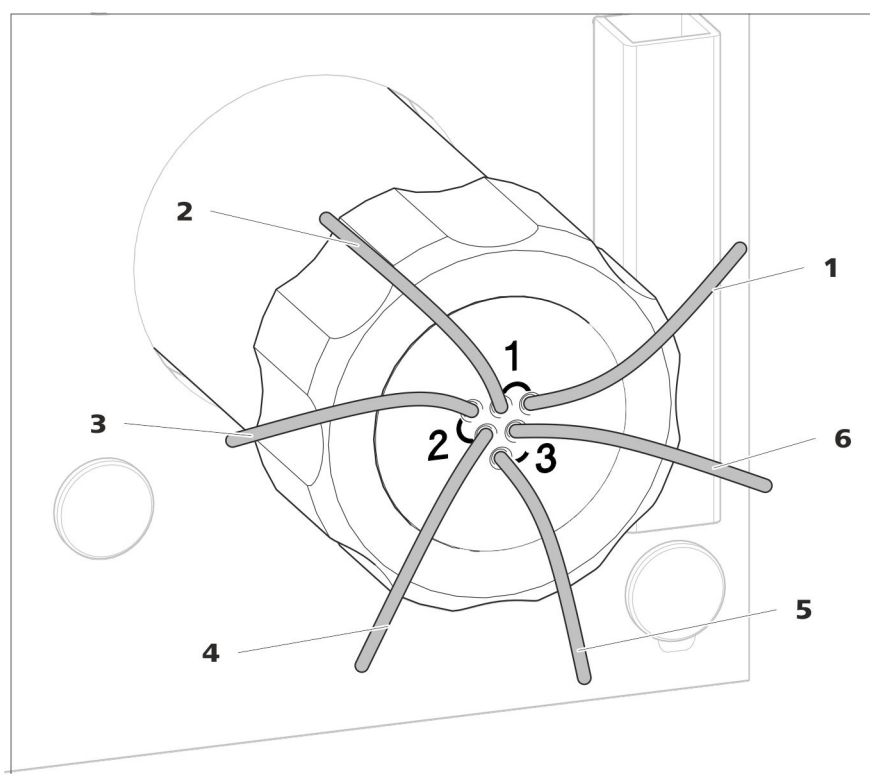

Figure 13 Metrohm Suppressor Module (MSM) – Connection capillaries

**1 out**  
Outlet capillary for the eluent.

**2 in**  
Inlet capillary for the eluent.

**3 regenerant**  
Inlet capillary for the regeneration solution.

**5 waste rins.**  
Outlet capillary for the rinsing solution; to the waste container.

**4 waste reg.**  
Outlet capillary for the regeneration solution; to the waste container.

**6 rinsing solution**  
Inlet capillary for the rinsing solution.

### Recommended installation

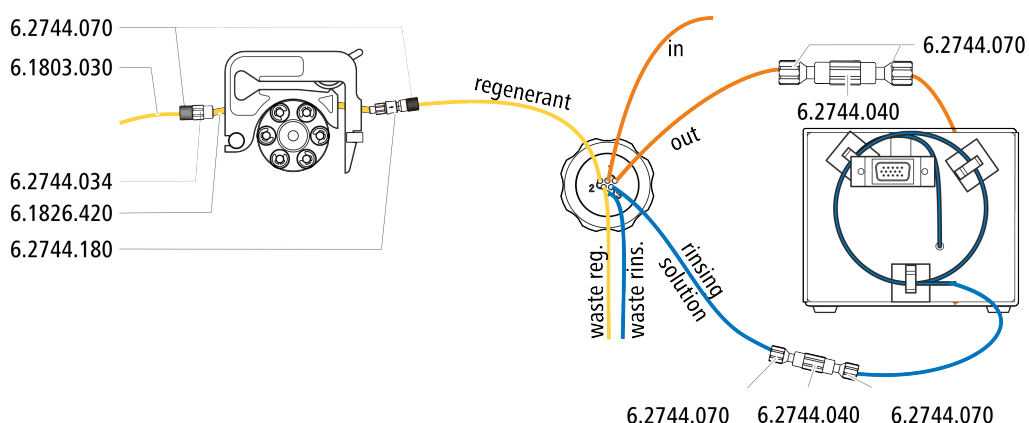

### Alternative installation

For the alternative installation, a second tubing cartridge (6.2755.000) is required that must be ordered separately with the following accessories:

- Tubing cartridge (6.2755.000)
- Coupling olive/UNF 10/32 2x (6.2744.034)
- Pump tubing connection with locking nut and filter (6.2744.180)
- Pump tubing PharMed® (orange/yellow) 3 stoppers (6.1826.420)
- Glass bottle / 1000 mL / GL 45 (6.1608.020)
- Bottle cap / GL 45 - 3 × UNF 10/32 (6.1602.150)
- PTFE capillary, 0.5 mm inner diameter / 3 m (6.1803.030)

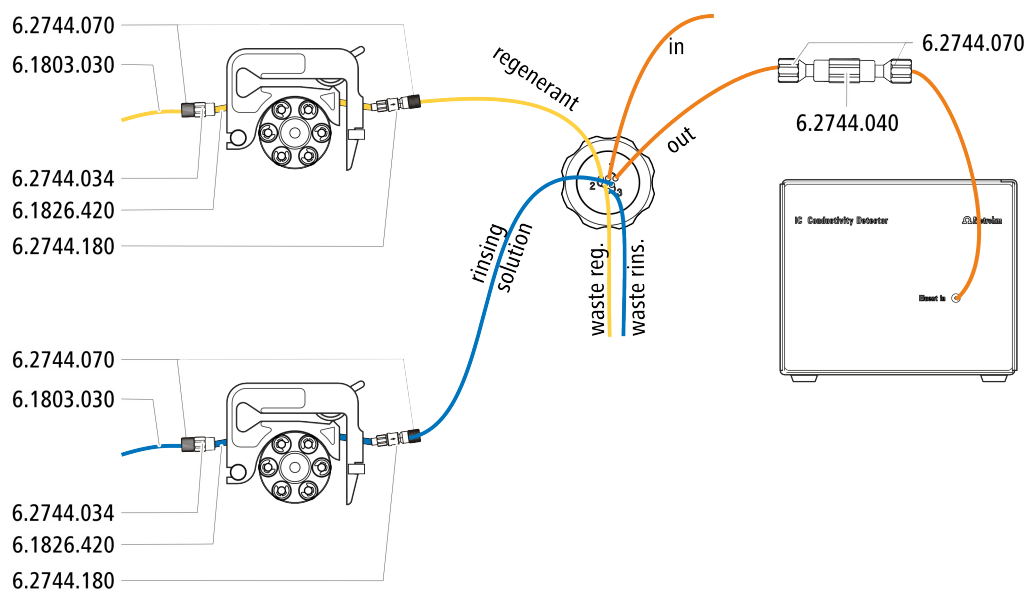

### 3.12.2.1 Installing the eluent path

The eluent path is connected with the capillaries *in* and *out*.

- 1 Connect the capillary labeled *in* to the outlet of the separation column using a short pressure screw (6.2744.070).
- 2 Connect the capillary labeled *out* to the detector inlet capillary using one coupling (6.2744.040) and two pressure screws (6.2744.070) (see manual of the conductivity detector).

### 3.12.2.2 Installing bottles with auxiliary solutions

#### Accessories

To connect the bottles of the auxiliary solutions, you will need the following accessories:

- Accessories from the accessory kit: IC Vario/Flex ChS (6.5000.030)

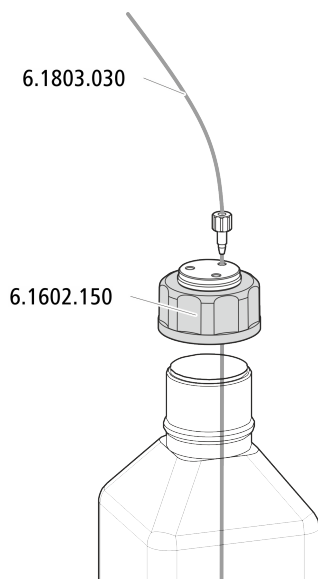

### 3.12.2.3 Connecting the regeneration solution

The regeneration solution is connected to the *regenerant* capillary.

#### Connecting the regeneration solution to the peristaltic pump

For this step, you need the following accessories:

- Accessory kit: Flex/Vario: ChS (6.5000.030)
- Pump tubing (6.1826.420)
- Tubing olive with filter and locking nut (6.2744.180)
- Tubing olive (6.2744.034)
- Tubing cartridge of the peristaltic pump

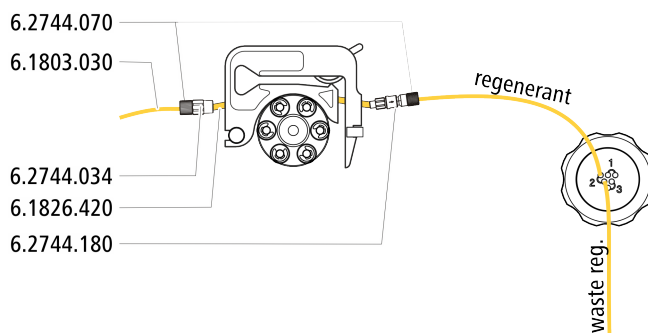

- 1** Prepare a tubing cartridge of the peristaltic pump for the regeneration solution (*see chapter 3.13.1, page 38*).
- 2** Connect the capillary labeled *regenerant* to the outlet of the pump tubing using a pressure screw (6.2744.070).
- 3** Connect the PTFE capillary from the regeneration solution bottle to the inlet of the pump tubing.

### 3.12.2.4 Connecting the rinsing solution

Various possibilities exist for rinsing the Metrohm Suppressor Module:

- Rinsing solution via STREAM (recommended)  
Use the eluent from the conductivity detector as rinsing solution.
- Rinsing solution via peristaltic pump  
Prepare the rinsing solution in a separate bottle and convey it with the peristaltic pump.

The rinsing solution is connected to the *rinsing solution* capillary.

#### Connecting the rinsing solution inlet with STREAM

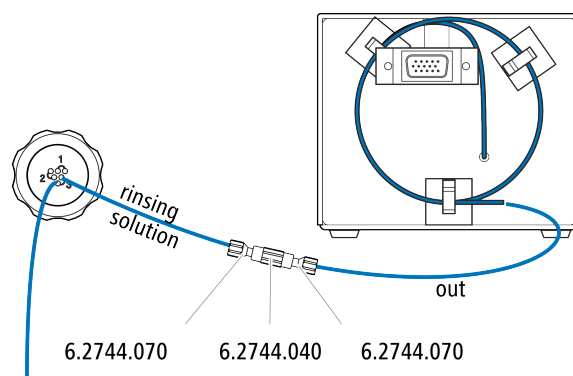

- 1 Connect the detector outlet capillary of the conductivity detector and the capillary labeled *rinsing solution* to each other using a coupling (6.2744.040) and two pressure screws (6.2744.070).



#### NOTE

The detector outlet capillary must not be shortened.

#### Connecting the rinsing solution inlet to the peristaltic pump

For this step, you need the following accessories: (not contained in its entirety in the standard accessories):

- Pump tubing (6.1826.420)
- Tubing olive with filter and locking nut (6.2744.180)
- Tubing olive (6.2744.034)
- Tubing cartridge (6.2755.000)
- 2 short pressure screws (6.2744.070)
- PTFE capillary (6.1803.030) (connected with the bottle with the rinsing solution)

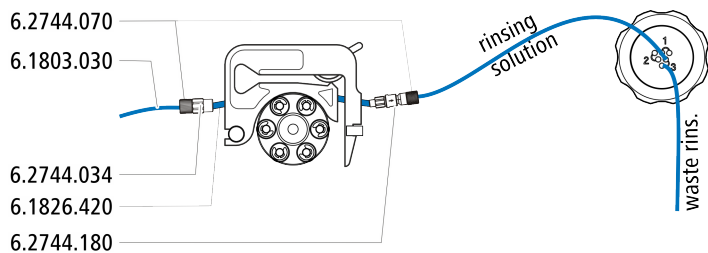

- 1** Prepare a tubing cartridge of the peristaltic pump for the regeneration solution (see chapter 3.13.1, page 38).
- 2** Connect the capillary labeled *rinsing solution* to the outlet of the pump tubing using a pressure screw (6.2744.070).
- 3** Connect the PTFE capillary from the rinsing solution bottle to the inlet of the pump tubing.

### 3.13 Peristaltic pump

#### 3.13.1 Installing the peristaltic pump

##### Installing the pump tubing

Pump tubing can differ in terms of material, diameter and thus flow rate. Different pump tubing is used depending on the application.

Table 2 Pump tubings



Order number	Name	Material	Inner diameter	Use
6.1826.310	Pump tubing LFL (orange/green), 3 stoppers	PVC (Tygon®)	0.38 mm	Pump tubing for bromate determination using the triiodide method.
6.1826.320	Pump tubing LFL (orange/yellow), 3 stoppers	PVC (Tygon®)	0.48 mm	For acceptor solutions for Inline Dialysis and for Inline Ultrafiltration.
6.1826.330	Pump tubing LFL (orange/white), 3 stoppers	PVC (Tygon®)	0.64 mm	No special applications.
6.1826.340	Pump tubing LFL (black/black), 3 stoppers	PVC (Tygon®)	0.76 mm	For sample solution in Inline Dialysis.
6.1826.360	Pump tubing LFL (white/white), 3 stoppers	PVC (Tygon®)	1.02 mm	For sample transfer.
6.1826.380	Pump tubing LFL (gray/gray), 3 stoppers	PVC (Tygon®)	1.25 mm	For Inline Dilution.

Order number	Name	Material	Inner diameter	Use
6.1826.390	Pump tubing LFL (yellow/yellow), 3 stoppers	PVC (Tygon®)	1.37 mm	For sample solution in Inline Ultrafiltration.
6.1826.420	Pump tubing PharMed® (orange/yellow), 3 stoppers	Ismaprene	0.51 mm	For suppressor solutions.

### Selecting the pump tubing and adapter

- 1 Select pump tubing suitable for the application (*see table 2, page 38*).
- 2 Select an adapter suitable for the pump tubing. The adapters are included with the pump tubing connection with locking nut and filter (6.2744.180).

Table 3 Pump tubing and suitable adapters

Pump tubing	Adapter
6.1826.310 (orange/green)	
6.1826.320 (orange/yellow)	
6.1826.330 (orange/white)	
6.1826.340 (black/black)	
6.1826.360 (white/white)	
6.1826.380 (gray/gray)	
6.1826.390 (yellow/yellow)	
6.1826.420 (orange/yellow)	

### Installing the pump tubing

For this step, you need the following accessories:

- Tubing cartridge (6.2755.000)
- Pump tubing (6.1826.XXX)
- Coupling olive/UNF 10/32 (6.2744.034)



- Pump tubing connection with locking nut and filter (6.2744.180): Includes a locknut, 3 adapters and a tubing olive with filter holder.
- 2 × pressure screw, short (6.2744.070)

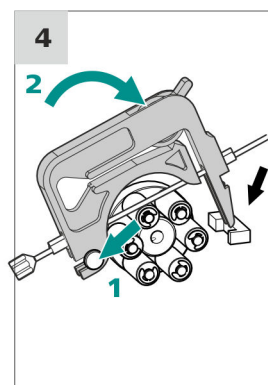
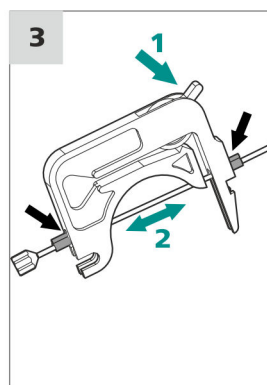
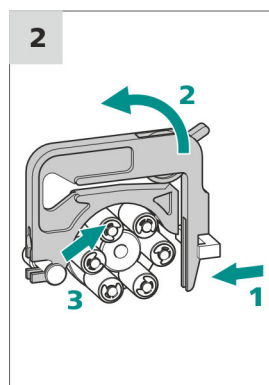
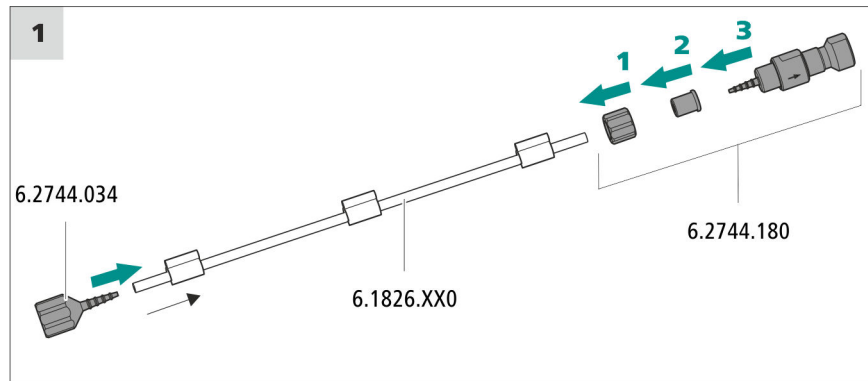

### 1 Connecting the pump tubing

- Attach the coupling olive/UNF 10/32 (6.2744.034) to the pump tubing entry. Push the end of the pump tubing over at least the second notch of the olive so that the pump tubing is firmly in place.
- Assemble the pump tubing connection with locking nut and filter (6.2744.180) at the pump tubing exit:
  - Push the locknut onto the pump tubing.
  - Push the appropriate adapter onto the pump tubing.
  - Place the tubing olive with the filter holder into the pump tubing so that the pump tubing is firmly in place; push the end of the pump tubing over at least the second notch of the olive.
  - Tighten it using the union nut.

### 2 Removing the tubing cartridge

- Press in the tubing cartridge's snap-action lever.
- Tilt the tubing cartridge upwards.
- Unhook the tubing cartridge from the mounting bolt.

### 3 Inserting the pump tubing

- Press the tubing cartridge's contact pressure lever down all the way.
- Place the pump tubing in the tubing cartridge. Fit the tubing cartridge between two stoppers. The stoppers must snap into the corresponding holder of the tubing cartridge.

### 4 Inserting the tubing cartridge

- Hang the tubing cartridge in the mounting bolt and press it in the cartridge holder until you hear the snap-action lever snap in.

### Setting the flow rate

The flow rate of the peristaltic pump depends on many factors:

- The inner diameter of the pump tubing
- The rotational speed of the drive
- The contact pressure of the tubing cartridge



#### NOTE

Pieces of pump tubing are consumables. The service life of the pump tubing depends on the contact pressure, among other factors.

### Setting the contact pressure correctly

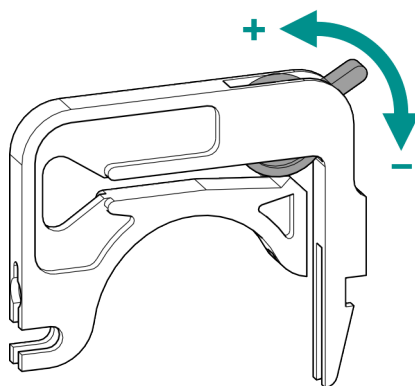

- 1 ▪ Fully loosen the contact pressure lever, i.e. press it all the way down.
  - In the software, activate the drive of the peristaltic pump with the desired speed.
  - Raise the contact pressure lever one step at a time until liquid flows.



- When liquid starts flowing, raise the contact pressure lever by an additional two ratchet increments.

The contact pressure is now set optimally.

### 3.13.2 Mode of operation for the peristaltic pump

The peristaltic pump is used for pumping sample and auxiliary solutions. It can rotate in both directions.

The peristaltic pump pumps liquids based on the principle of displacement. The pump tubing is clamped between the rollers (14-5) and the tubing cartridge (14-2). During operation, the peristaltic pump drive rotates the roller hub (14-6), so that the rollers (14-5) advance the liquid in the pump tubing.

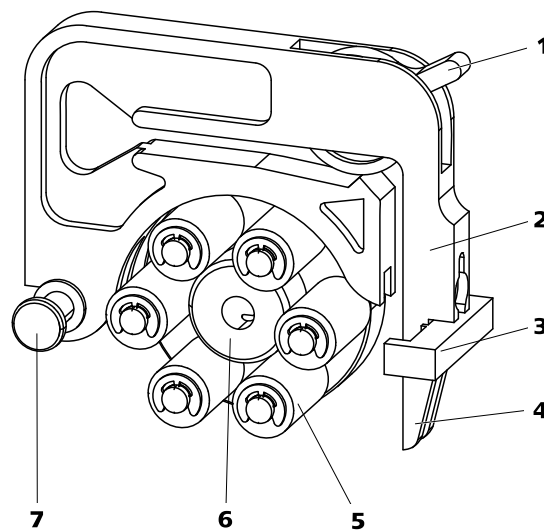

Figure 14 Peristaltic pump

<b>1</b>	<b>Contact pressure lever</b>	<b>2</b>	<b>Tubing cartridge (6.2755.000)</b>
<b>3</b>	<b>Cartridge holder</b>	<b>4</b>	<b>Snap-action lever</b>
<b>5</b>	<b>Rollers</b>	<b>6</b>	<b>Roller hub</b>
<b>7</b>	<b>Mounting bolt</b>		

## 3.14 Installing the conductivity detector

The 930 Compact IC Flex provides enough space for one detector and additional accessories in the detector chamber. The detector is available as separate device and is supplied with a separate manual.

### Placing the detector in the instrument

Follow the instructions in the chapter *Inserting the detector* in the manual for the detector.

### Connecting the detector to the eluent path



#### NOTE

The separation column is not inserted into the instrument until it is being started up for the first time. Until then, the detector inlet capillary has to be connected to the *out* capillary of the Metrohm Suppressor Module (MSM) using a coupling (6.2744.040).

#### Accessories

For this step, you need the following accessories:

- Coupling (6.2744.040)
- 2 × pressure screw (6.2744.010)

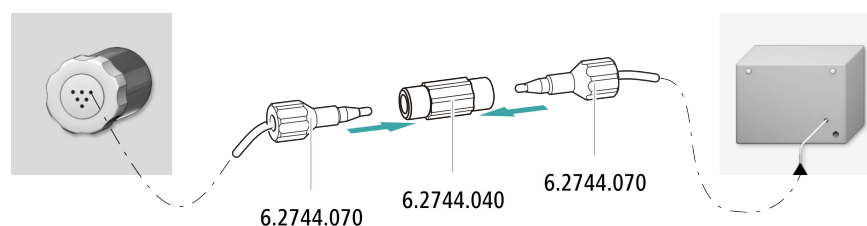

- 1 Connect the *out* capillary of the Metrohm Suppressor Module (MSM) and the detector inlet capillary to each other using a coupling (6.2744.040) and two short pressure screws (6.2744.070).



## Connecting the sample degasser

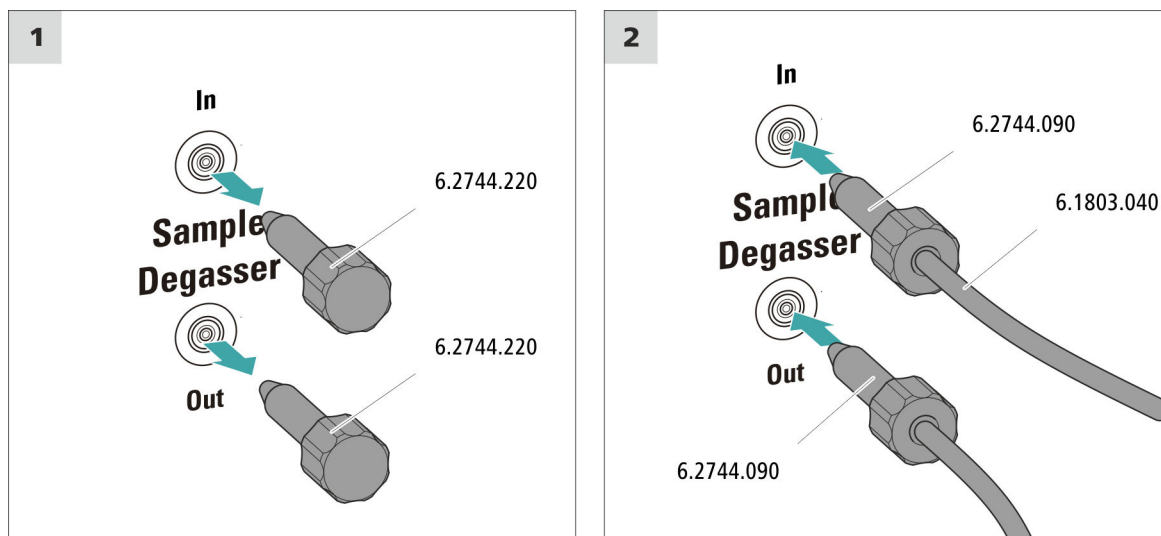

### CAUTION

If the sample degasser is not used, the inlet and outlet **must** be sealed with threaded stoppers (6.2744.220).

#### 1 Removing the threaded stoppers

Remove and keep the threaded stoppers (6.2744.220) from the inlet and outlet of the sample degasser.

#### 2 Connecting the outlet capillary

- Push a long pressure screw over the loose end of the capillary connected to Port 1 of the injection valve.
- Tighten the pressure screw to the outlet of the sample degasser (labeled **Out**).  
Try to ensure the shortest possible connections (shorten the capillary if necessary).

#### 3 Connecting the inlet capillary

- Push a long pressure screw over one end of the PTFE capillary (6.1803.040) and tighten the pressure screw to the inlet of the sample degasser (labeled **In**).



## 3.18 Connecting the instrument to the power grid



### WARNING

#### Electric shock from electrical potential

Risk of injury by touching live components or through moisture on live parts.

- Never open the housing of the instrument while the power cord is still connected.
- Protect live parts (e.g. power supply unit, power cord, connection sockets) against moisture.
- Unplug the power plug immediately if you suspect that moisture has gotten inside the instrument.
- Only personnel who have been issued Metrohm qualifications may perform service and repair work on electrical and electronic parts.

#### Connecting the power cord

#### Accessories

Power cord with the following specifications:

- Length: max. 2 m
- Number of cores: 3, with protective conductor
- Instrument plug: IEC 60320 type C13
- Conductor cross-section 3x min. 1.0 mm<sup>2</sup> / 18 AWG
- Power plug:
  - according to customer requirement (6.2122.XX0)
  - min. 10 A



### NOTE

Do not use a not permitted power cord!

#### 1 Plugging in the power cord

- Plug the power cord into the instrument's power socket.
- Connect the power cord to the power grid.



### 3 Starting equilibration

- Start the equilibration in MagIC Net: **Workplace ► Run ► Equilibration ► Start HW.**

### 4 Deaerating the high-pressure pump

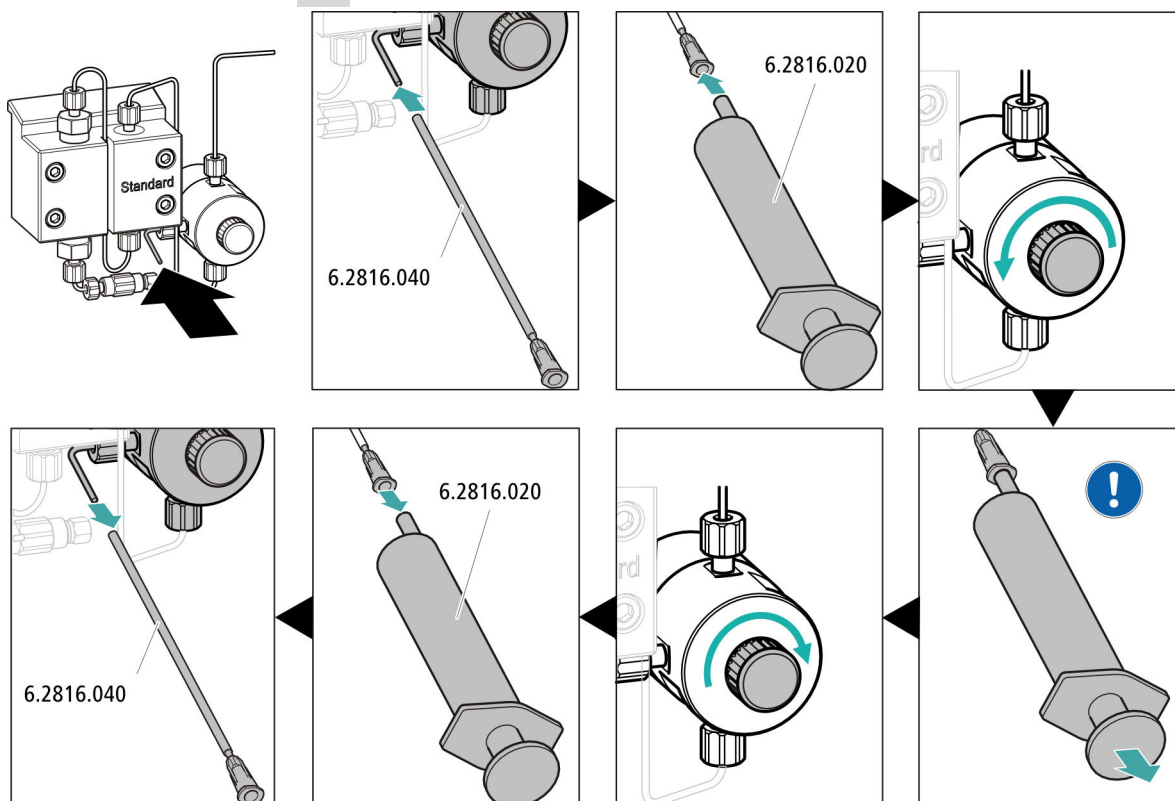

- Push the end of the purge needle (6.2816.040) over the end of the purge capillary on the purge valve.
- Insert the syringe (6.2816.020) in the Luer connector of the purge needle.
- Open the purge valve using the rotary knob (approx.  $\frac{1}{2}$  turn).
- Switch on the high-pressure pump in MagIC Net.
- Use the syringe to aspirate eluent until there are no more air bubbles in the eluent aspiration tubing.
- Switch off the high-pressure pump in MagIC Net.
- Seal the purge valve using the rotary knob.
- Remove the syringe from the purge needle.
- Pull the purge needle out of the purge capillary.

### 5 Adjusting the contact pressure of the peristaltic pump

- Adjust the contact pressure of the peristaltic pump (see "Setting the contact pressure correctly", page 41).



### 6 Rinsing the instrument without columns

- Rinse the instrument (without columns) with eluent for 10 minutes.

## 3.20 Connecting and rinsing the guard column

Guard columns protect separation columns and significantly increase their service life. The guard columns available from Metrohm are either actual guard columns or guard column cartridges used together with a cartridge holder. The process of installing a guard column cartridge into the corresponding holder is described in the guard column leaflet.



#### NOTE

Metrohm recommends always working with guard columns. They protect the separation columns and can be replaced regularly as needed.



#### NOTE

Information regarding which guard column is suitable for your separation column can be found in the **Metrohm Column Program** (which is available from your Metrohm representative), the leaflet provided along with your separation column or the product information about the separation column at <http://www.metrohm.com> (Ion Chromatography product area), or it can be obtained directly from your representative.



#### CAUTION

New guard columns are filled with a solution and sealed with stoppers or caps on both sides.

Before inserting the guard column, ensure that this solution can be mixed with the eluent being used (follow the information provided by the manufacturer).

**NOTE**

The guard column may not be connected until after the instrument has already been put into operation once (*see chapter 3.19, page 48*). The guard column and the separation column have to be replaced by a coupling (6.2744.040) until then.

*Accessories*

For this step, you need the following accessories:

- Guard column (suitable for separation column)

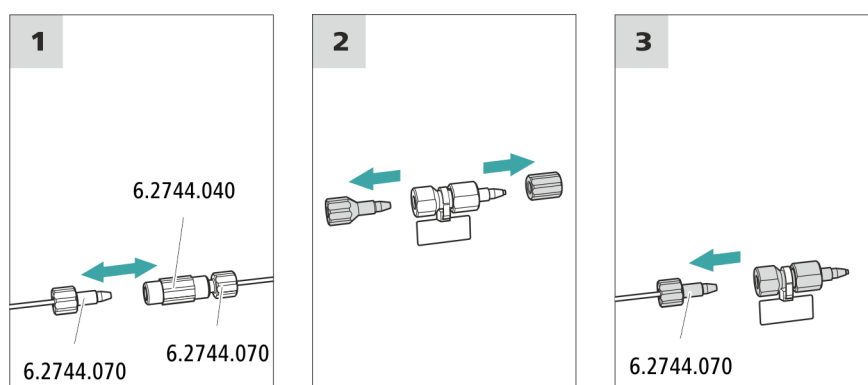
**Connecting the guard column****1 Removing the coupling**

Remove the coupling (6.2744.040) installed between the column inlet capillary and the column outlet capillary for the initial start-up.

**2 Preparing the guard column**

- Remove the stoppers or the stopper and the sealing cap from the guard column.

**3 Connecting the guard column****CAUTION**

When inserting the guard column, ensure that it is inserted correctly based on the marked flow direction (if specified).

- Fasten the inlet of the guard column to the column inlet capillary using a short pressure screw (6.2744.070).



- If the guard column is connected to the separation column using a connection capillary, fasten this connection capillary to the guard column outlet with a pressure screw.

### Rinsing the guard column

#### 1 Rinsing the guard column

- Place a beaker under the guard column's outlet.
- Start manual control in MagIC Net and select the high-pressure pump: **Manual ▶ Manual control ▶ Pump**
  - **Flow: in accordance with column leaflet**
  - **On**
- Rinse the guard column with eluent for approx. 5 minutes.
- Stop the high-pressure pump in the manual control in MagIC Net again: **Off**.

## 3.21 Connecting the separation column

The smart separation column (iColumn) is the heart of ion chromatographic analysis. It separates the different components according to their interactions with the column. Metrohm separation columns are equipped with a chip where their technical specifications and history (start-up, operating hours, injections etc) are stored.



#### NOTE

Information regarding which separation column is suitable for your application can be found in the **Metrohm Column Program**, the product information for the separation column or it can be obtained through your representative.

You can find product information for your separation column at <http://www.metrohm.com> in the Ion Chromatography product area.

A test chromatogram and a leaflet accompanies every column. Detailed information on special IC applications can be found in the corresponding "**Application Bulletins**" or "**Application Notes**". You can find these online at <http://www.metrohm.com> in the Applications area or request them from your responsible Metrohm representative free of charge.

**CAUTION**

---

New separation columns are filled with a solution and sealed with stoppers on both sides. Before inserting the column, ensure that this solution can be mixed with the eluent being used (follow the information provided by the manufacturer).

**NOTE**

---

Connect the separation column only after the initial start-up of the instrument. Until that point, insert a coupling (6.2744.040) instead of the guard column and separation column.

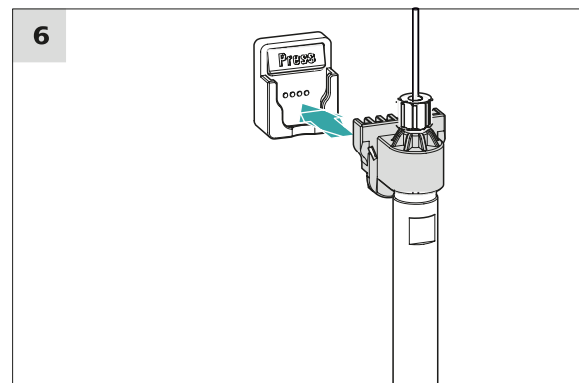
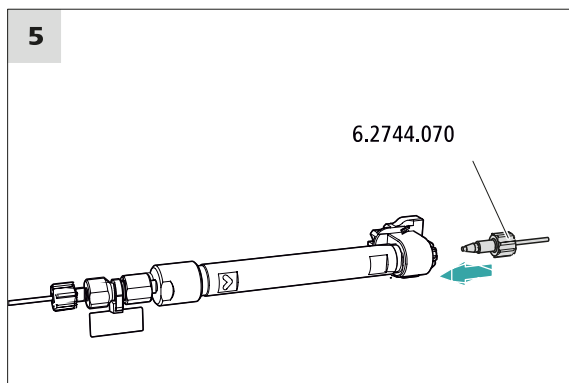
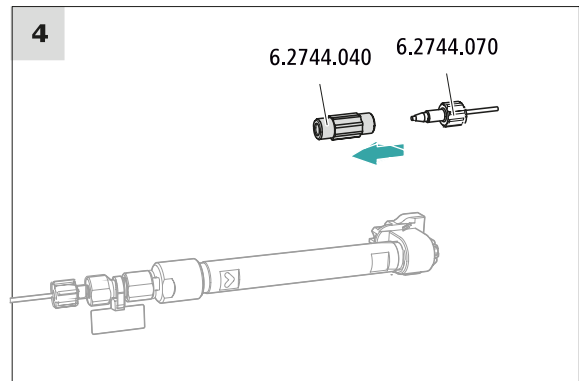
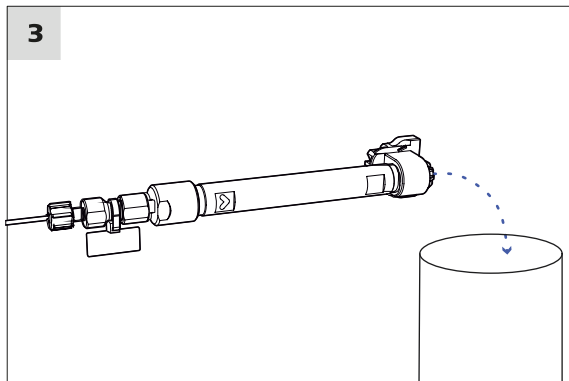
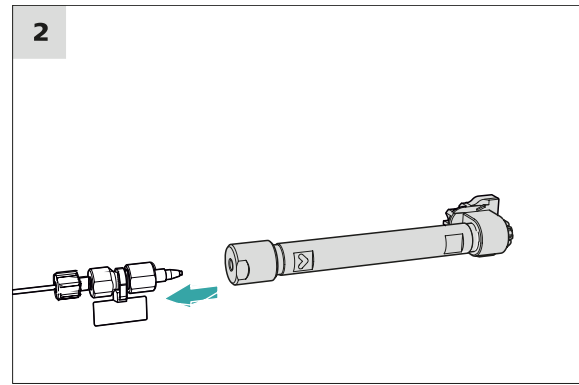
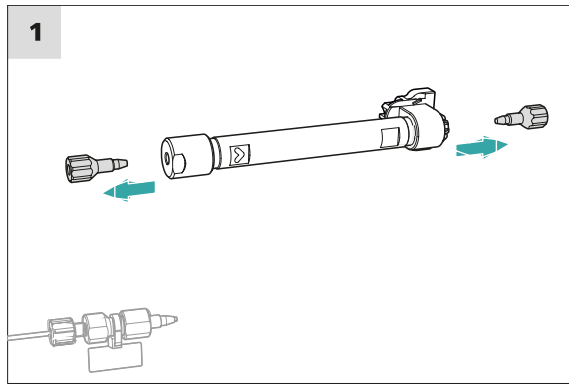

**Connecting the separation column**

- 1 Removing the stoppers**
  - Remove the stoppers from the separation column.

## 2 Installing the inlet of the separation column



### CAUTION

When inserting the column, ensure that it is inserted correctly based on the marked flow direction.

There are three options:

- Attach the column inlet directly onto the guard column or,
- if the guard column is connected to the separation column using a connection capillary: Connect the column inlet to the guard column outlet capillary using a PEEK pressure screw (6.2744.070) or,
- if no guard column is used (not recommended): Connect the column inlet capillary to the inlet of the separation column using a short pressure screw (6.2744.070).

## 3 Rinsing the separation column

- Place a beaker under the outlet of the separation column.
- Start manual control in MagIC Net and select the high-pressure pump: **Manual ▶ Manual control ▶ Pump**
  - **Flow**: Increase gradually up to the flow rate recommended in the column leaflet.
  - **On**
- Rinse the separation column with eluent for approx. 10 minutes.
- Stop the high-pressure pump in the manual control in MagIC Net again: **Off**.

## 4 Removing the coupling

- Remove the coupling (6.2744.040) from the column outlet capillary.

## 5 Installing the outlet of the separation column

- Fasten the column outlet capillary to the column outlet using a short PEEK pressure screw (6.2744.070).

## 6 Inserting the separation column

- Insert the separation column with the chip into the column holder until you hear it snap in place.

The separation column is now detected by MagIC Net.

## 3.22 Conditioning

In the following cases, the system must be conditioned with eluent until a stable baseline has been reached:

- After installation
- After each time the instrument is switched on
- After each eluent change



### NOTE

The conditioning time can lengthen considerably if the composition of the eluent is modified.

### Conditioning the system

#### 1 Preparing the software



### CAUTION

Ensure that the configured flow rate is not higher than the flow rate permitted for the corresponding column (refer to the column leaflet and chip data record).

- Start the **MagIC Net** computer program.
- Open the **Equilibration** tab in MagIC Net: **Workplace ► Run ► Equilibration**.
- Select (or create) a suitable method.  
Also see: *MagIC Net Tutorial* and online help.

#### 2 Preparing the instrument

- Ensure that the column is inserted correctly in accordance with the flow direction marked on the sticker (arrow has to point in the direction of flow).
- Ensure that the eluent aspiration tubing is immersed in the eluent and that there is enough eluent in the eluent bottle.

#### 3 Starting equilibration

- Start the equilibration in MagIC Net: **Workplace ► Run ► Equilibration ► Start HW**.

- Visually inspect whether all capillaries and their connections from the high-pressure pump to the detector are leak-tight. If eluent is leaking out anywhere, tighten the corresponding pressure screw further, or loosen the pressure screw, check the end of the capillary and shorten it using the capillary cutter if necessary and retighten the pressure screw.

#### **4 Conditioning the system**

Continue rinsing the system with eluent until the desired stability level for the baseline has been attained .

The instrument is now ready for measuring samples.

## 4 Operation

The 930 Compact IC Flex Oven/ChS/PP/Deg is operated solely using the MagIC Net software. You can find information on operating the software in the tutorial for MagIC Net or in the online help.

## 5 Operation and maintenance

### 5.1 IC system

#### 5.1.1 Operation

In order to avoid disruptive temperature influences, protect the analysis system, including the eluent bottle, from direct sunlight.

#### 5.1.2 Care

The instrument requires appropriate care. Excess contamination of the instrument results in malfunctions and a reduction in the service life of the sturdy mechanical and electronic components.

The instrument must be cleaned immediately if chemicals or solvents are spilled on it. In particular, the plug connections (particularly the power plug) must be protected against contamination.



#### CAUTION

The instrument has been designed so that liquid is largely prevented from being able to get inside the instrument. However, unplug the power plug immediately if you suspect that corrosive media have gotten inside the instrument. This is the only way to prevent extreme damage to the instrument electronics. Notify Metrohm Service.



#### WARNING

##### Electric shock caused by live parts

Never open the housing of the instrument.

Only trained personnel are permitted to open the housing of the instrument.

#### 5.1.3 Maintenance by Metrohm Service

Maintenance of the instrument is best carried out as part of an annual service performed by specialist personnel from Metrohm. A shorter maintenance interval is recommended if you frequently work with caustic and corrosive chemicals. Metrohm Service offers every form of technical advice for maintenance and service of all Metrohm instruments.



## 5.2 Capillary connections

All capillary connections between the injection valve, the separation column and the detector must be as short as possible, have a low dead volume and be completely leak-tight.

The PEEK capillary downstream of the detector must be free of blockages.

Use only PEEK capillaries with an inner diameter of 0.25 mm between the high-pressure pump and the detector (high-pressure section).

## 5.3 Servicing the door



### CAUTION

The door is made of PMMA (poly(methyl methacrylate)). It must never be cleaned with abrasive media or solvents.



### CAUTION

Never hold the instrument by the door when lifting it. Only hold the instrument by the housing.

## 5.4 Column oven – Replacing the capillaries

There are preheating grooves in the inner side wall of the column oven, where the column inlet capillary has already been inserted and fastened in place with a holder plate.

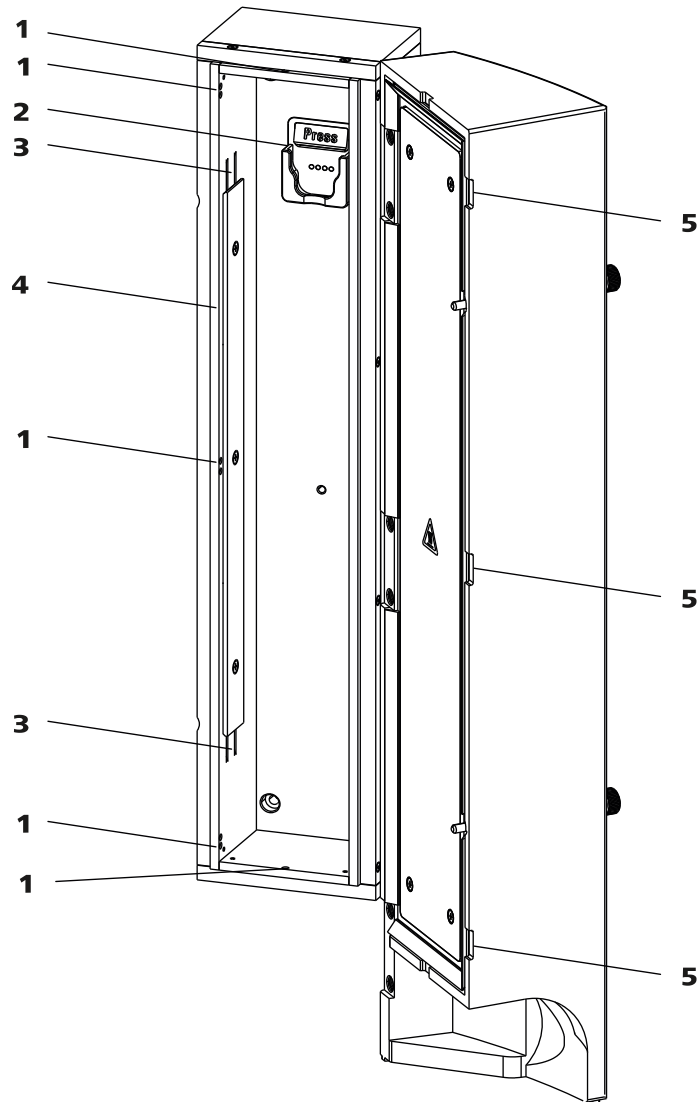

Figure 15 Column oven

**1 Openings**

For feeding through the capillaries.

**3 Preheating grooves**

For threading in the capillary to be temperature-conditioned.

**5 Recesses**

Prevent the capillaries from being pinched.

**2 Column holder**

For hanging the separation column (iColumn). With column recognition.

**4 Holder plate**

For securing the capillary in place.

### Replacing the preheating capillary

In order to make threading the column inlet capillary into the column oven's preheating grooves easier, we recommend loosening the screws for the holder plate a little, but not removing them all the way.

- 1 Guide the column inlet capillary into the column oven via one of the recesses at the bottom (15-1).
- 2 Push the column inlet capillary into the outer preheating groove (15-3) from the bottom. Continue pushing it through under the holder plate until it comes back out the top.
- 3 Carefully bend the column inlet capillary downward and push it through the inner preheating groove until it comes out at the bottom edge of the holder plate.

## 5.5 Handling the eluent

Careful handling of the eluent ensures stable analysis results. Keep the following general measures in mind when handling the eluent:

- The supply bottle with the eluent must be connected as indicated in *chapter 3.6, page 21*. This is particularly important for eluents with volatile solvents (e.g. acetone).
- Avoid condensation in the eluent bottle. Drop formation can change the concentration ratio in the eluent.
- In the case of very sensitive measurements, we recommend that the eluent be stirred constantly with a magnetic stirrer (e. g. the 2.801.0010 with 6.2070.000).
- To protect the IC system from foreign particles, we recommend aspirating the eluent via an aspiration filter (*see chapter 3.6, page 21*) (6.2821.090). This aspiration filter must be replaced as soon as it turns yellow but at least every 3 months.

### 5.5.1 Manufacturing eluent

Chemicals used for manufacturing eluents must have a purity grade of at least "p.a.". They may be diluted only by using ultrapure water (resistance > 18.2 M $\Omega$ \*cm). (These specifications apply generally for all reagents used in ion chromatography.)

Newly manufactured eluents always need to be microfiltered (0.45  $\mu$ m filter).



### Connecting the connecting tubing

- 1 ▪ Insert the clamping screws on the connector and screw them in by hand.
  - Tighten the clamping screws with the wrench.

## 5.7 Notes on operating the high-pressure pump



### CAUTION

The pump head is filled ex works with methanol/ultrapure water. Ensure that the eluent used is miscible with this solvent.

Keep the following recommendations in mind in order to protect the high-pressure pump from damage as much as possible during operation:

- To protect the high-pressure pump from **foreign particles**, we recommend filtering the eluent through a filter with a pore size of 0.45 µm and aspirating it via an aspiration filter (6.2821.090).
- Ensure that no precipitates can form when changing the eluent. Salt crystals between the piston and seal cause abrasive particles that can find their way into the eluent. These particles lead to contaminated valves, an increase in pressure and, in extreme cases, scratched pistons and thus to leakages in the high-pressure pump. Immediately successive solutions must always be miscible. If the system must be rinsed with organic solvents, use several solvents with rising or falling lipophilicity.
- In order to protect the pump seals, ensure that the pump is never operated dry. Therefore ensure that the eluent supply is correctly connected and that there is enough eluent in the eluent bottle each time before turning on the pump.



## 5.8 Servicing the high-pressure pump



### NOTE

You can find a video sequence for this task in the *Multimedia Guide IC Maintenance* or on the Internet at <http://ic-help.metrohm.com/>.

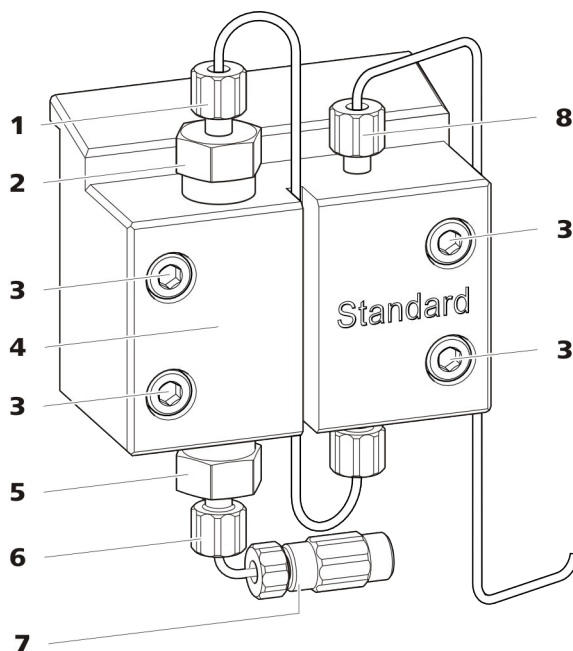

Figure 16 High-pressure pump – Parts

<b>1</b>	<b>Pressure screw, short (6.2744.070)</b> Fastened to the outlet valve holder.	<b>2</b>	<b>Outlet valve holder</b>
<b>3</b>	<b>Fastening screw</b>	<b>4</b>	<b>Pump head</b>
<b>5</b>	<b>Inlet valve holder</b>	<b>6</b>	<b>Pressure screw, short (6.2744.070)</b> Fastened to the inlet valve holder.
<b>7</b>	<b>Eluent aspiration tubing connector</b> Consists of a coupling with a pressure screw.	<b>8</b>	<b>Pressure screw, short (6.2744.070)</b> Fastened to the pump output.

### Maintenance interval

The following parts of the high-pressure pump must be serviced at least once per year:

- Inlet valve (6.2824.170)
- Outlet valve (6.2824.160)
- Piston seal (6.2741.020)
- Zirconium oxide piston (6.2824.070)

Maintenance tasks can also be carried out if the following problems occur:

- Unstable baseline (pulsations, flow fluctuations)



### CAUTION

Maintenance work on the high-pressure pump may not be carried out unless the **instrument is switched off**.

#### *Recommended procedure*

We recommend the following procedure for the maintenance of the pump head:

1. Service the inlet valve and the outlet valve.
2. Remove the pump head.
3. Service both pistons, one after the other.
  - a. Remove piston.
  - b. Dismantle the piston.
  - c. Replace the piston seal.
  - d. Replace the zirconium oxide piston.
  - e. Assemble the piston.
  - f. Insert the piston.
4. Reinstall the pump head.

You can find brief video sequences on the following maintenance steps on the Internet at <http://ic-help.metrohm.com/>.

#### **Servicing the outlet valve and inlet valve**

#### *Accessories*

For this step, you need the following accessories:

You can find these parts in the accessory kit: *Vario/Flex Basic* (6.5000.000).

- Adjustable wrench (6.2621.000)

### Cleaning the outlet valve

#### Spare parts

If the outlet valve cannot be cleaned, you will need a new outlet valve (6.2824.160) for this step.

#### 1 Removing the outlet valve

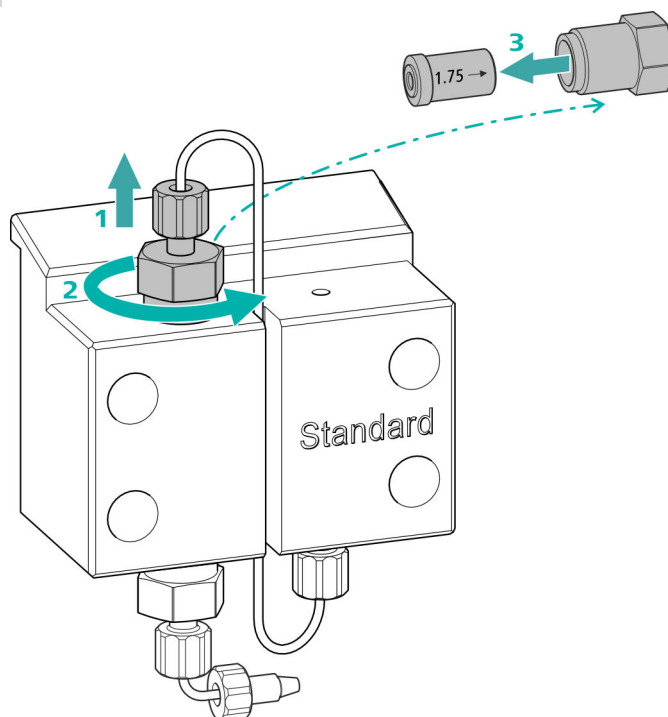

- Unscrew the connection capillary to the auxiliary piston from the outlet valve holder (16-2) (1).
- Start by loosening the outlet valve holder with the adjustable wrench and then unscrew it by hand (2) and remove it.
- Remove the outlet valve from the outlet valve holder (3).

#### 2 Cleaning the outlet valve

- Start by rinsing the outlet valve in the direction of eluent flow using a wash bottle filled with ultrapure water, RBS™ solution or acetone. (The direction of eluent flow is marked on the valve by an arrow.)  
The rinsing solution must come out at the valve outlet.  
If no more solution comes out, then the valve is blocked.
- Rinse the outlet valve in the direction opposite the eluent flow using a wash bottle filled with ultrapure water, RBS™ solution or acetone.  
The rinsing solution may only come out at the valve outlet.

The outlet valve must be replaced if it is still clogged after cleaning.

### 3 Reinserting the outlet valve into the pump head

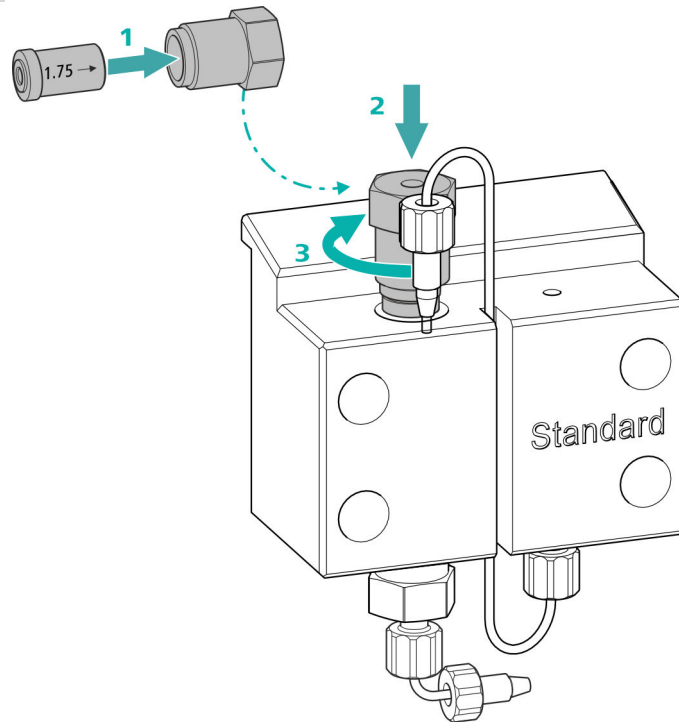

- Insert the outlet valve into the outlet valve holder (the seal must be visible) **(1)**.
- Screw the outlet valve holder up into the pump head **(2)** and tighten it firmly by hand and then retighten it one additional  $\frac{1}{4}$  turn using the adjustable wrench **(3)**.
- Tighten the connection capillary to the auxiliary piston back onto the outlet valve holder.

### Cleaning the inlet valve

*Spare parts*

If the inlet valve cannot be cleaned, you will need a new inlet valve (6.2824.170) for this step.

#### 1 Removing the inlet valve

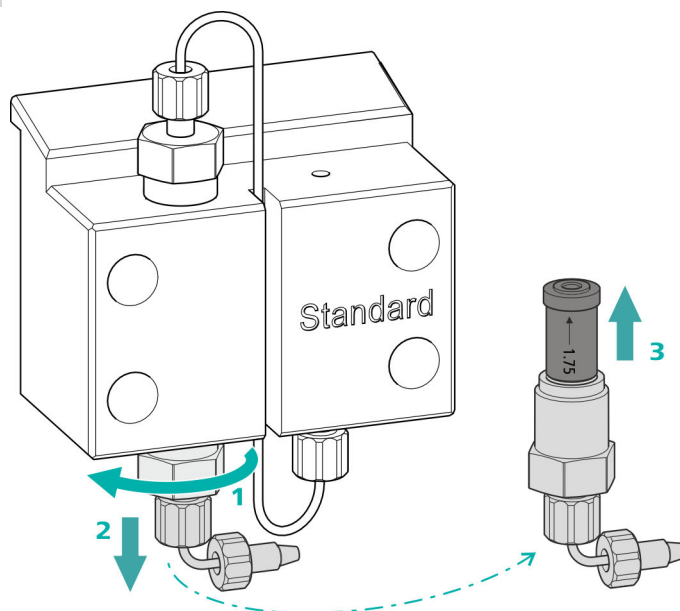

- Unscrew the connection capillary to the connection of the eluent aspiration tubing (16-7).
- Start by loosening the inlet valve holder with the adjustable wrench (1) and then unscrew it by hand (2) and remove it.
- Remove the inlet valve from the inlet valve holder (3).

#### 2 Cleaning the inlet valve

- Start by rinsing the inlet valve in the direction of eluent flow using a wash bottle filled with ultrapure water, RBS™ solution or acetone. (The direction of eluent flow is marked on the valve by an arrow.)

The rinsing solution must come out at the valve outlet.

If no more solution comes out, then the valve is blocked.

- Rinse the inlet valve in the direction opposite the eluent flow using a wash bottle filled with ultrapure water, RBS™ solution or acetone.

The rinsing solution may only come out at the valve outlet.

The inlet valve must be replaced if it is still clogged after cleaning.

### 3 Reinserting the inlet valve into the pump head

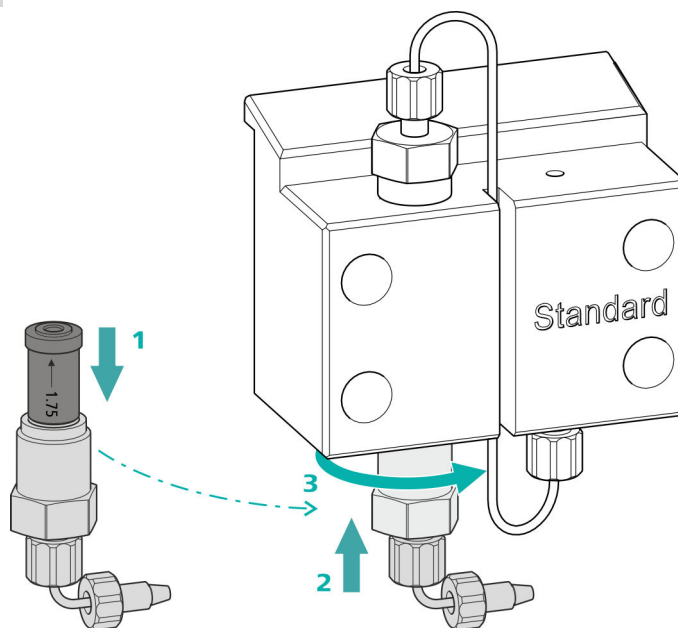

- Insert the inlet valve into the inlet valve holder (the seal must be visible) (1).
- Screw the inlet valve holder up into the pump head (2) and tighten it firmly by hand and then retighten it one additional  $\frac{1}{4}$  turn using the adjustable wrench (3).
- Refasten the connection capillary to the connection of the eluent aspiration tubing (16-7).

### Removing the pump head

#### Accessories

For this step, you need the following accessories:

You can find these parts in the accessory kit: *Vario/Flex Basic* (6.5000.000).

- 4 mm hex key (6.2621.030)

### Removing the pump head

Prerequisites:

- Is the high-pressure pump switched off?
- Has the pressure been released?
- Is the instrument switched off?

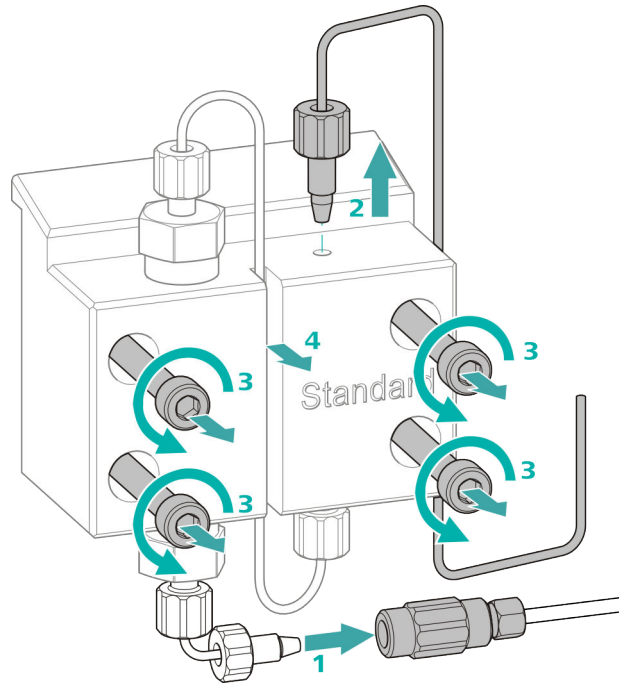

- 1** Release the coupling from the pressure screw and seal it with a stopper.
- 2** Unscrew and remove the pressure screw on the pump head's outlet (16-8).
- 3** Loosen and remove the four fastening screws (16-3) using the hex key.
- 4** Remove the pump head (16-4).

### Servicing the piston

Carry out the following work on both pistons in turn.

Servicing a piston consists of the following tasks:

1. Replace the piston seal.
2. Clean or replace the zirconium oxide piston.
3. Reinstall the piston.

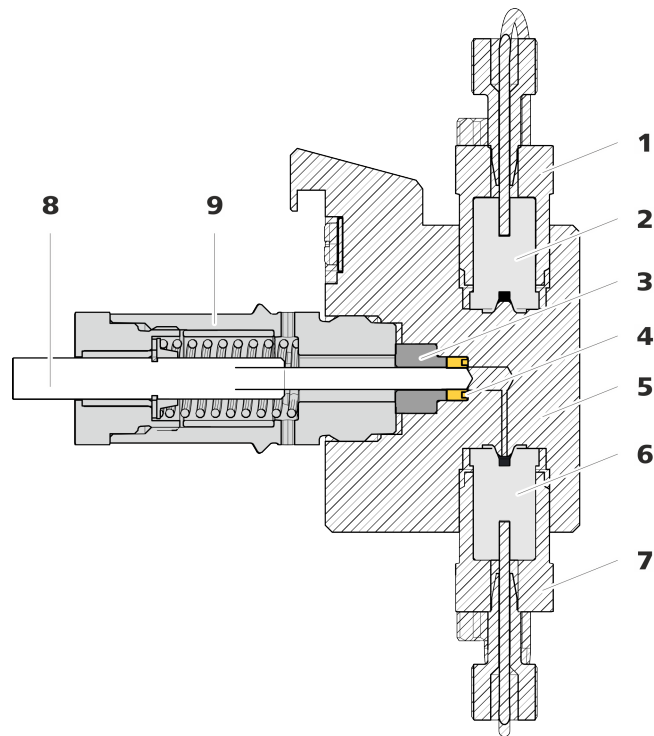

Figure 17 High-pressure pump – Cross-section

<b>1</b>	<b>Outlet valve holder</b>	<b>2</b>	<b>Outlet valve (6.2824.160)</b>
<b>3</b>	<b>Backup ring</b>	<b>4</b>	<b>Piston seal (6.2741.020)</b>
<b>5</b>	<b>Pump head</b>	<b>6</b>	<b>Inlet valve (6.2824.170)</b>
<b>7</b>	<b>Inlet valve holder</b>	<b>8</b>	<b>Zirconium oxide piston (6.2824.070)</b>
<b>9</b>	<b>Piston cartridge</b>		

#### Accessories

For this step, you need the following accessories:

You can find these parts in the accessory kit: *Vario/Flex Basic* (6.5000.000).

- Adjustable wrench (6.2621.000)
- Tool for piston seals (6.2617.010) consisting of a tip (**18-1**) for removing the old piston seal and a sleeve (**18-2**) for inserting the new piston seal.

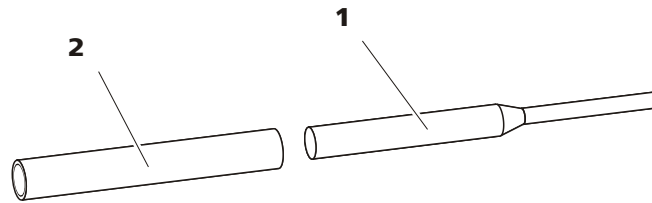

Figure 18 Tool for piston seal (6.2617.010)

**1 Tip**

**2 Sleeve**

*Spare part*

For this step, you need a new piston seal (6.2741.020).

### Replacing the piston seal

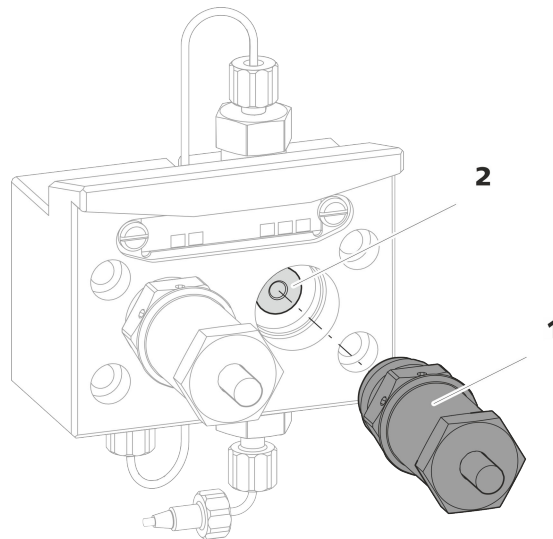

Figure 19 Removing the piston cartridge from the pump head

**1 Piston cartridge**

**2 Backup ring**

#### 1 Removing the piston cartridge

Loosen the piston cartridge (19-**1**) using the adjustable wrench and then unscrew it from the pump head by hand. Set it aside.

#### 2 Removing the backup ring

Shake the backup ring (19-**2**) out of the piston opening. Set it aside.

### 3 Removing the old piston seal



#### CAUTION

Screwing the (6.2617.010) special tool for the piston seal into the piston seal destroys this completely!



#### CAUTION

Avoid touching the sealing surface in the pump head with the tool!

Only screw the tip (18-1) of the tool for the piston seal far enough into the piston seal that the seal can be pulled out.

### 4 Inserting the new piston seal into the tool

Insert the new piston seal into the recess of the sleeve (20-1) of the tool for piston seal. The sealing spring must be visible from the outside.

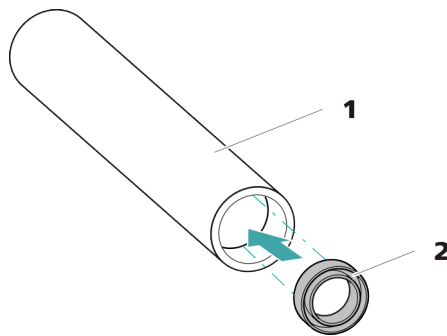

Figure 20 Inserting the piston seal into the tool

#### 1 Tool for piston seal (6.2617.010)

Sleeve for inserting the new piston seal.

#### 2 Piston seal (6.2741.020)

### 5 Inserting the new piston seal into the pump head

Guide the sleeve (18-2) of the tool for the piston seal with inserted piston seal into the pump head. Press the seal into the pump head recess using the wide end of the tip (18-1) of the tool.

### Cleaning or replacing the zirconium oxide piston

Prerequisites:



- The pump head has been removed (see "Removing the pump head", page 71).
- The piston cartridge is removed (see "Replacing the piston seal", page 74).

For this task, you need the following accessories:

- Zirconium oxide piston (6.2824.070)
- Adjustable wrench (6.2621.000) from the accessory kit: *Vario/Flex Basic* (6.5000.000).

### 1 Breaking down the piston cartridge



#### CAUTION

Inside the piston cartridge there is a taut spring that can launch out of the piston cartridge if the tension is released suddenly.

When opening the piston cartridge, counteract the pressure from the spring and carefully unscrew the cartridge.

- Loosen the piston cartridge's screw with an adjustable wrench and carefully unscrew the screw by hand while counteracting the pressure from the taut spring.
- Remove the zirconium oxide piston and place it on a paper towel.
- Remove the spring retainer, the spring and the inner plastic sleeve from the piston cartridge and lay them next to the piston.
- Place the backup ring you put aside with the remaining parts.

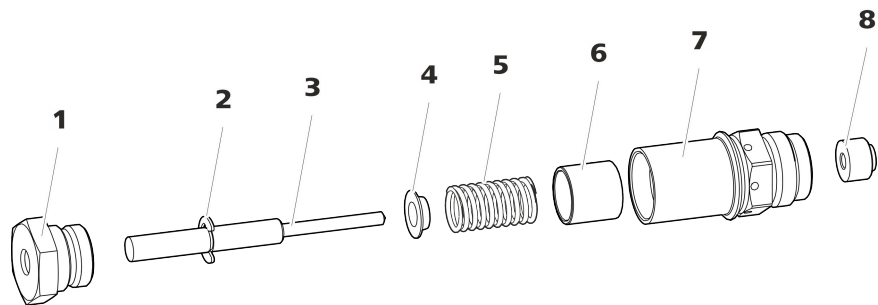

Figure 21 Parts of the piston cartridge

<b>1</b>	<b>Piston cartridge screw</b>	<b>2</b>	<b>Retaining washer</b>
<b>3</b>	<b>Zirconium oxide piston (6.2824.070)</b>	<b>4</b>	<b>Spring retainer</b>
<b>5</b>	<b>Spring (6.2824.060)</b>	<b>6</b>	<b>Inner plastic sleeve</b> Protects from metallic abrasion.
<b>7</b>	<b>Piston cartridge</b>	<b>8</b>	<b>Backup ring</b>

## 2 Cleaning the parts of the piston cartridge

- If the zirconium oxide piston has become contaminated due to abrasion or deposits, then clean it using a fine abrasive cleaning powder, rinse it using ultrapure water until it is free of particles and dry it.

The zirconium oxide piston must be replaced if it is heavily contaminated or scratched.

- Rinse the other parts of the piston with ultrapure water and dry with a lint-free cloth.

## 3 Replacing the zirconium oxide piston

- Remove the retaining washer (21-2) from the old piston. If the retaining washer sits too tightly, use a pointed object to loosen the retaining washer.
- Assemble the retaining washer at the same point on the new piston.

## 4 Putting the piston cartridge together

- Insert the inner plastic sleeve, the spring and the spring retainer into the piston cartridge.
- Slide the zirconium oxide piston carefully into the piston cartridge until its tip emerges from the small opening of the piston cartridge.
- Attach the screw and tighten it by hand.

## Mounting the piston

### 1 Reinserting the backup ring

Clean the backup ring (17-3) with ultrapure water and reinsert it.

### 2 Reinserting the piston cartridge

Screw the assembled piston cartridge back into the pump head and tighten, first by hand, then also using an adjustable wrench by approx. 15°.

Clean the second piston cartridge in the same way.

## Mounting the pump head

For this step, you need the following accessories:

You can find these parts in the accessory kit: *Vario/Flex Basic* (6.5000.000).

*Accessories*



- 4 mm hex key (6.2621.030)

### Mounting the pump head



#### NOTE

The pump head cannot be mounted the wrong way, as it has fastening bolts with different bore hole depths, i.e., one fastening bolt is longer than all others. The bore hole with the greatest depth must therefore be aligned with the longest bolt.

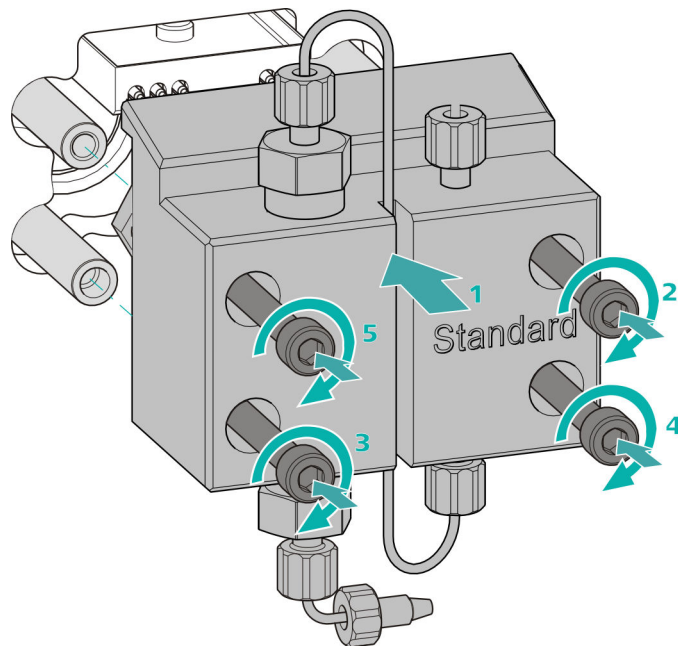

- 1** ▪ Push the pump head onto the four fastening bolts (1).  
▪ Tighten the four fastening screws using the hex key (6.2621.030) alternating crosswise.

### Connecting the entry and exit for the high-pressure pump

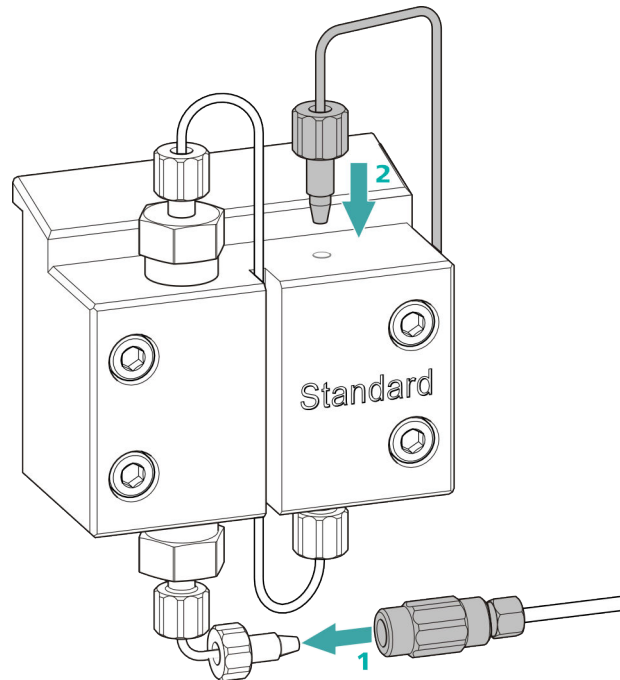

- 1
  - Remove the stopper from the coupling. Tighten the coupling to the pressure screw located on the pump head inlet capillary (1).
  - Reconnect the pump head outlet capillary to the pump head outlet (2).

## 5.9 Servicing the inline filter



### NOTE

You can find a video sequence for this task in the *Multimedia Guide IC Maintenance* or on the Internet at <http://ic-help.metrohm.com/>.

#### Maintenance interval

The filter must be replaced at least every 3 months; it may need to be replaced more frequently, depending on the application.

#### Accessories

For this task, you need the following accessories:

- Two adjustable wrenches (6.2621.000) from the accessory kit: Vario/Flex Basic (6.5000.000)
- Tweezers
- A new filter from the packaging (6.2821.130)



### Removing the filter

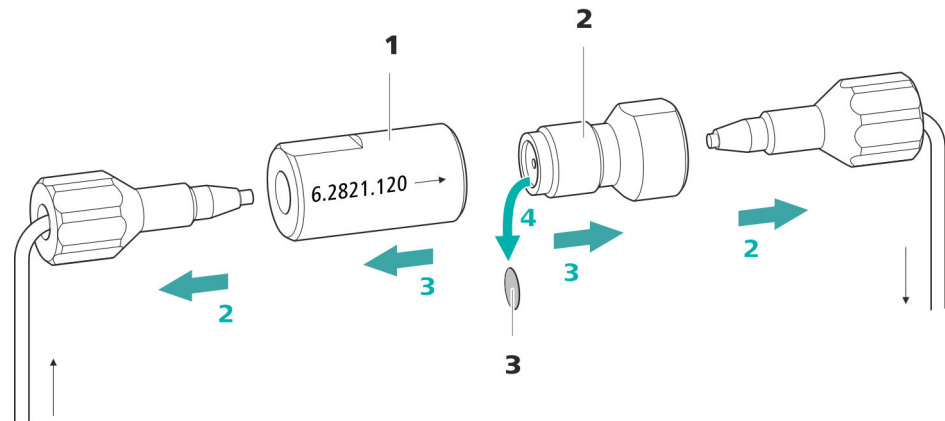

Figure 22 Inline filter – Removing the filter

#### 1 Filter housing

Inline filter housing. Part of the accessories (6.2821.120).

#### 2 Filter screw

Screw for the inline filter. Part of the accessories (6.2821.120).

#### 3 Filter (6.2821.130)

Pack contains 10 pieces.

#### 1 Shutting off the flow

Switch off the high-pressure pump in the software.

#### 2 Removing the inline filter

Unscrew both pressure screws from the inline filter.

#### 3 Unscrewing the filter screw

Use two adjustable wrenches (6.2621.000) to loosen the filter screw (22-2) from the filter housing (22-1) and unscrew it by hand.

#### 4 Removing the filter

Remove the old filter (22-3) using tweezers.

### Inserting a new filter

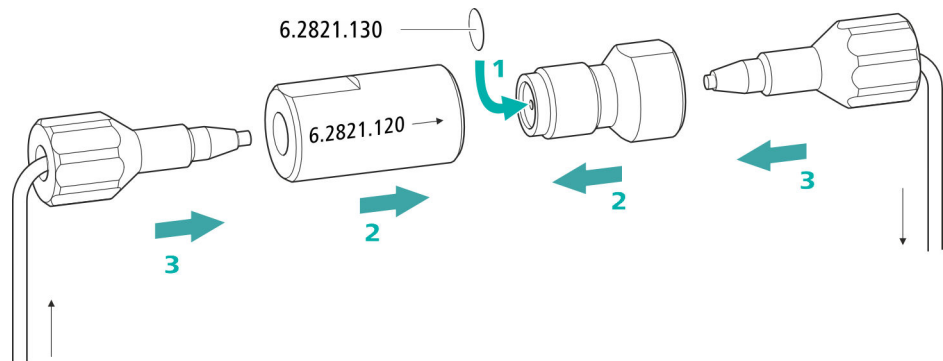

#### 1 Inserting a new filter

- Use tweezers to carefully place a new filter into the filter screw (22-2) so that it is flat and press it firmly into place with the rear of the tweezers.

#### 2 Installing the filter screw

- Screw the filter screw (22-2) back into the filter housing (22-1) and tighten by hand. Then use two adjustable wrenches (6.2621.000) to tighten it slightly.

#### 3 Remounting the inline filter

- Screw pressure screws back onto the inline filter. Take care to ensure that the flow direction matches that inscribed on the inline filter.

#### 4 Rinsing the inline filter

- Dismantle the guard column (if present) and the separation column and replace with a coupling (6.2744.040).
- Rinse the instrument with eluent.
- Reinsert the columns after 10 minutes.

## 5.10 Servicing the pulsation absorber



### CAUTION

---

The pulsation absorber is maintenance-free and must not be opened.

## 5.11 Injection valve

Maintenance on the injection valve is best performed by specialist personnel from Metrohm during annual service.

## 5.12 Metrohm Suppressor Module (MSM)

### 5.12.1 Notes for operating the Metrohm Suppressor Module (MSM)



### NOTE

---

The suppressor units must never be regenerated in the same flow direction the eluent is pumped. Therefore, always mount the inlet and outlet capillaries according to the diagram outlined in *Chapter Connecting the Metrohm Suppressor Module (MSM)*, page 33.

The Metrohm Suppressor Module (MSM) consists of three suppressor units, which, in rotation, are (1.) used for suppression, (2.) regenerated with regeneration solution and (3.) rinsed with ultrapure water or with suppressed eluent. In order to record each new chromatogram under comparable conditions, work is normally performed with a freshly regenerated and rinsed suppressor unit.



### CAUTION

---

The Metrohm Suppressor Module (MSM) must never be switched over if liquid is not flowing through it, since otherwise it may become jammed. If the Metrohm Suppressor Module (MSM) is in a dry state, it must be rinsed for at least five minutes before it may be switched over.

**CAUTION**

The Metrohm Suppressor Module (MSM) must be regenerated (see chapter 5.12.3.2, page 84), cleaned (see chapter 5.12.3.4, page 86) or replaced (see chapter 5.12.3.5, page 89) if the capacity of the Metrohm Suppressor Module (MSM) is reduced or if the backpressure is high.

## 5.12.2 Taking care of the suppressor housing

**CAUTION**

### The transparent suppressor housing can become fogged.

The suppressor housing is made of PMMA (poly(methyl methacrylate)). It can become scratched and foggy if cleaned improperly. This can make viewing the rotor difficult or impossible.

- Do **not use any scouring agents** for cleaning.
- Do **not use any solvents** for cleaning.

## 5.12.3 Servicing the Metrohm Suppressor Module (MSM)

### 5.12.3.1 Parts of the Metrohm Suppressor Module (MSM)

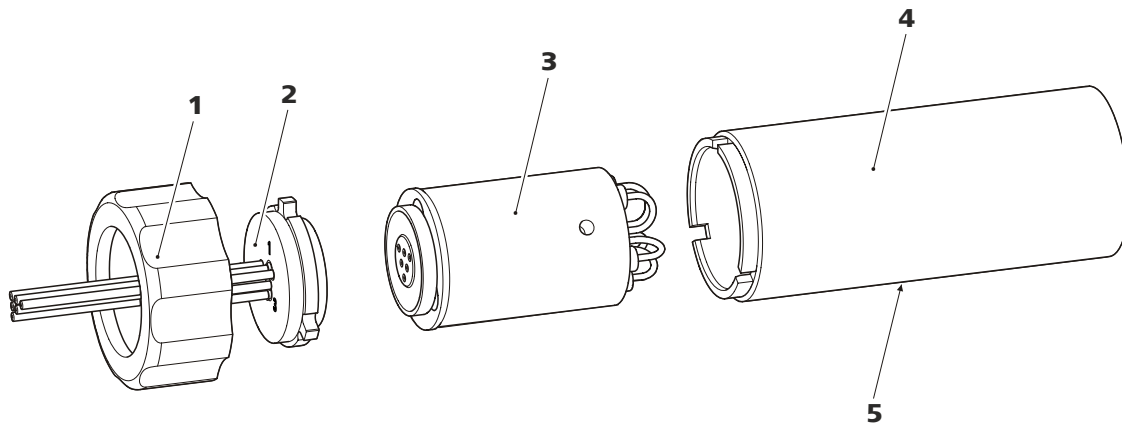

Figure 23 Parts of the Metrohm Suppressor Module (MSM)

**1** Union nut

**3** Rotor

**5** Slot in the housing

**2** Connecting piece

**4** Housing



## 2 Regenerating the Metrohm Suppressor Module (MSM)

Regenerate the three suppressor units one after the other for approx. 15 minutes using one of the solutions mentioned above.

- Connect the capillary labeled **regenerant** to the outlet of the high-pressure pump using a coupling (6.2744.040).
- Set the flow of the high-pressure pump to 0.5 mL/min in the software.
- Connect the regeneration solution to the high-pressure pump.
- Switch on the high-pressure pump.  
If the pressure decreases during regeneration, slowly increase the flow of the pump to a maximum of 2 mL/min. When doing so, make sure that the pressure does not exceed 2 MPa!
- After approx. 15 minutes, switch off the high-pressure pump.
- In the software, use the **Step** command to switch to the next suppressor unit and regenerate it as described above.
- As soon as all three suppressor units have been regenerated, disconnect the capillary labeled **regenerant** from the coupling.

## 3 Rinsing the Metrohm Suppressor Module (MSM)

After regeneration, each of the three suppressor units must be rinsed with degassed ultrapure water for about 15 minutes.

- Connect the capillary labeled **rinsing solution** to the outlet of the high-pressure pump using a coupling (6.2744.040).
- Set the flow of the high-pressure pump to 0.5 mL/min in the software.
- Connect the ultrapure water to the high-pressure pump.
- Switch on the high-pressure pump.  
If the pressure decreases during rinsing, slowly increase the flow of the pump to a maximum of 2 mL/min. When doing so, make sure that the pressure does not exceed 2 MPa!
- After approx. 15 minutes, switch off the high-pressure pump.
- In the software, use the **Step** command to switch to the next suppressor unit and rinse it as described above.
- As soon as all three suppressor units have been rinsed, disconnect the capillary labeled **rinsing solution** from the coupling.

## 4 Connecting the Metrohm Suppressor Module (MSM) to the IC system

- Reconnect the capillaries of the MSM labeled **regenerant** and **rinsing solution** to the IC system.
- Reconnect the entry and the exit of the high-pressure pump to the IC system.



- Irremediable blockage of the MSM (solutions can no longer be pumped through the MSM).
- Irremediable jamming of the MSM (MSM can no longer be switched over).

## Cleaning the Metrohm Suppressor Module (MSM)

### 1 Disconnecting the Metrohm Suppressor Module (MSM) from the IC system

- Switch off the instrument.
- Disconnect all capillaries of the MSM from the IC system.

### 2 Dismantling the Metrohm Suppressor Module (MSM)

- Unscrew the union nut (23-1) from the housing (23-4).
- Pull the connecting piece (23-2) out of the housing together with the rotor (23-3).

If the rotor gets stuck in the housing, you can push it out as follows:

Put a pointed object into the slot in the housing and use it to push out the rotor.

- Loosen the connecting piece from the rotor with a turning movement.

### 3 Rinsing the capillaries

- Connect each of the six PTFE capillaries connected to the connecting piece (23-2) in sequential order to the high-pressure pump and pump ultrapure water through them.
- Check whether water comes out at the connecting piece.

If one of the capillaries remains blocked, the connecting piece (see *"Replacing parts of the Metrohm Suppressor Module (MSM)"*, page 89) must be replaced (order number 6.2835.010).

### 4 Cleaning the rotor

- Clean the sealing surface of the rotor (23-3) with ethanol using a lint-free cloth.

### 5 Inserting the rotor



#### CAUTION

The rotor may be destroyed during start-up if it is not inserted correctly.

For an overview of the rotors, see figure , page 30

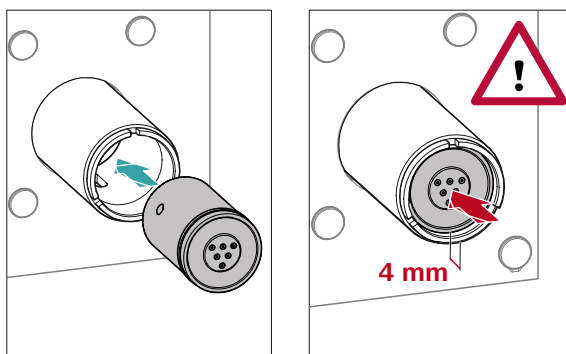

- Insert the rotor (23-3) into the housing (23-4) in such a way that the tubing connections on the rear of the rotor fit into the corresponding recesses inside the housing and one of the three holes of the rotor is visible from below in the slot of the housing (23-5).



#### NOTE

The rotor's sealing surface is located approx. 4 mm deep inside the suppressor drive if the rotor is inserted correctly.

If this is not the case, then the rotor must be moved into the correct position using careful turning. If the rotor cannot be turned or removed, it can be moved into the correct position from below by means of a pointed object (e.g. a screwdriver).

### 6 Cleaning the connecting piece

- Clean the sealing surface of the connecting piece (23-2) with ethanol using a lint-free cloth.

### 7 Inserting the connecting piece

See also Chapter 3.12.1, page 30

- Insert the connecting piece (23-2) into the housing in such a way that connector 1 is on top and the three pins of the connecting piece fit into the corresponding recesses on the housing.
- Reattach the union nut (23-1) and tighten by hand (do not use a tool).

### 8 Connecting and conditioning the Metrohm Suppressor Module (MSM)

- Reconnect the MSM to the IC system.
- Before switching the MSM over for the first time, rinse each of the three suppressor units with solution for five minutes.

### 5.12.3.5 Replacing parts of the Metrohm Suppressor Module (MSM)

Parts of the Metrohm Suppressor Module (MSM) may need to be replaced in the following cases:

- Irremediable loss of suppressor capacity (reduced phosphate sensitivity and/or significant rise in the baseline).
- Irremediable blockage of the MSM (solutions can no longer be pumped through the MSM).

Both the rotor and the connecting piece can be replaced.

#### Replacing parts of the Metrohm Suppressor Module (MSM)

##### 1 Disconnecting the Metrohm Suppressor Module (MSM) from the IC system

- Switch off the instrument.
- Disconnect all capillaries of the MSM from the IC system.

##### 2 Dismantling the Metrohm Suppressor Module (MSM)

- Unscrew the union nut (23-1) from the housing (23-4).
- Pull the connecting piece (23-2) out of the housing together with the rotor (23-3).

If the rotor gets stuck in the housing, you can push it out as follows:

Put a pointed object into the slot in the housing and use it to push out the rotor.

- Loosen the connecting piece from the rotor with a turning movement.

##### 3 Cleaning the new rotor

- Clean the sealing surface of the new rotor (23-3) with ethanol using a lint-free cloth.

##### 4 Inserting the new rotor



#### CAUTION

The rotor may be destroyed during start-up if it is not inserted correctly.

**NOTE**

The adapter (6.2842.020) (see "Inserting small rotors", page 32) is required in order to insert a small rotor into the suppressor drive.

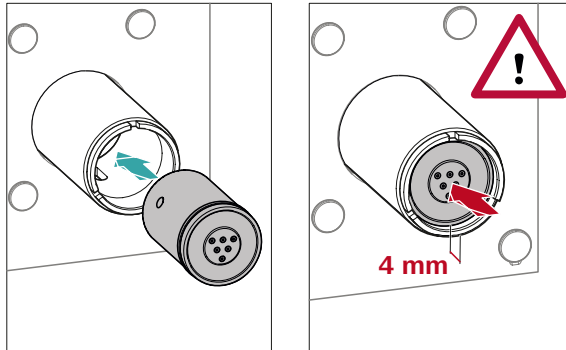

- Insert the new rotor (23-3) into the housing (23-4) in such a way that the tubing connections on the rear of the rotor fit into the corresponding recesses inside the housing and one of the three holes of the rotor is visible from below in the slot of the housing (23-5).

**NOTE**

The rotor's sealing surface is located approx. 4 mm deep inside the suppressor drive if the rotor is inserted correctly.

If this is not the case, then the rotor must be moved into the correct position using careful turning. If the rotor cannot be turned or removed, it can be moved into the correct position from below by means of a pointed object (e.g. a screwdriver).

**5 Cleaning the new connecting piece**

- Clean the sealing surface of the new connecting piece (23-2) with ethanol using a lint-free cloth.

**6 Inserting the new connecting piece**

See also Chapter 3.12.1, Page 30

- Insert the connecting piece (23-2) into the housing in such a way that connector 1 is on top and the three pins of the connecting piece fit into the corresponding recesses on the housing.
- Reattach the union nut (23-1) and tighten by hand (do not use a tool).

## 7 Connecting and conditioning the Metrohm Suppressor Module (MSM)

- Reconnect all capillaries of the MSM to the IC system.
- Before switching the MSM over for the first time, rinse the three suppressor units with solution for five minutes.

## 5.13 Peristaltic pump

### 5.13.1 Notes on operating the peristaltic pump

The flow rate of the peristaltic pump depends on the drive speed (set using the software), the contact pressure and, above all, the inner diameter of the pump tubing. Depending on the application, different pump tubing is used. Select pump tubing that best matches your application (see table 2, page 38).



#### CAUTION

The service life of the pump tubing primarily depends on the contact pressure.

If the peristaltic pump is switched off for long periods, lift up the tubing cartridges on the right side by releasing the snap-action levers. This ensures that the contact pressure will be maintained once it has been set.



#### CAUTION

The pump tubing (6.1826.xxx) is made of PVC or PP and therefore must not be used for rinsing with solutions containing organic solvents. In this case, use different pump tubing or use another pump for rinsing.

### 5.13.2 Servicing the peristaltic pump

#### 5.13.2.1 Replacing the pump tubing

Pieces of pump tubing inserted into the peristaltic pump are consumables with a limited service life.

Pieces of pump tubing with 3 stoppers are tensioned in the tubing cartridge so that they end up positioned between two stoppers. This results in two possible positions for the tubing cartridge. Once the pump tubing exhibits significant signs of wear, it can be tensioned a second time in the other respective position.

*Maintenance interval*    Replace the pump tubing every 2 months.



Replace the pump tubing every 4 weeks if the peristaltic pump is being used continuously.

### 5.13.2.2 Replacing the filter

The filters inserted into the pump tubing connection with locking nut and filter (6.2744.180) must be replaced regularly.

#### Maintenance interval

We recommend replacing the filters (6.2821.130) (24-2) every three months. The filters may need to be replaced more frequently, depending on the application.

#### Accessories

For this step, you need the following accessories:

- 1 filter from the spare filter set (6.2821.130)
- 2 adjustable wrenches (6.2621.000)
- Tweezers

### Replacing the filter

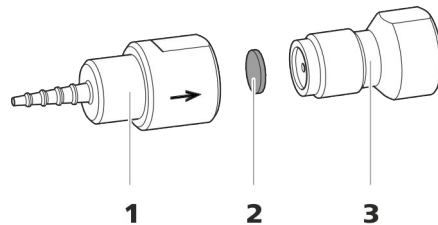

Figure 24 Pump tubing connection – Replacing the filter

**1** Tubing olive

**2** Filter (6.2821.130)

Pack contains 10 pieces.

**3** Filter screw

#### 1 Unscrewing the filter screw

- Unscrew the filter screw (24-3) from the tubing olive (24-1) using the two adjustable wrenches.

#### 2 Replacing the filter

- Remove the old filter (24-2) using tweezers.
- Use tweezers to place the new filter (24-2) on the filter screw (24-3) so that it is **flat** and press it firmly into place with the rear of the tweezers.

### 3 Installing the filter screw

- Screw the filter screw (24-3) back into the tubing olive (24-1) and start by tightening it by hand. Finish tightening it using the two adjustable wrenches.

## 5.14 Servicing the detector

Follow the maintenance instructions in the the detector's manual.

## 5.15 Rinsing the sample path

Before a new sample is measured, the sample path must be rinsed with it long enough to prevent the measuring result from being falsified by the previous sample (sample carry-over).

The time required to rinse the sample path with the new sample is called the rinsing time. The rinsing time depends on the transfer time.

The transfer time corresponds to the time the sample needs to flow from the sample vessel to the end of the sample loop. The transfer time depends on the following factors:

- The pump capacity of the peristaltic pump or of the Dosino that is used for the sample transfer.
- The total capillary volume
- The volume of the gas removed from the sample by the sample degasser (if a sample degasser is present and connected)

The transfer time can be determined as follows:

### Determining the transfer time

#### 1 Emptying the sample path

Pump air through the sample path (pump tubing, tubing connections, capillary in the degasser, sample loop) for several minutes until all liquid is displaced by the air.

#### 2 Unscrewing the sample loop

Unscrew the end of the sample loop.

#### 3 Aspirating the sample and measuring the time

Aspirate a sample typical for the later application and use a stopwatch to measure the time the sample needs to go from the sample vessel to the end of the sample loop.



The time upon stopping the watch is the "transfer time".

#### 4 Tightening the sample loop again

Tighten the sample loop again.

If the sample is injected automatically, the rinsing time must be at least three times the **transfer time**.

### Checking the rinsing time

You can determine if the applied rinsing time is sufficient by measuring the sample carry-over directly. Proceed as follows to do this:

#### 1 Preparing two samples

- **Sample A:** A typical sample for the application.
- **Sample B:** Ultrapure water.

#### 2 Determining "Sample A"

Allow "Sample A" to run through the sample path for the duration of the rinsing time; inject and then measure it.

#### 3 Determining "Sample B"

Allow "Sample B" to run through the sample path for the duration of the rinsing time; inject and then measure it.

#### 4 Calculating the sample carry-over

The sample carry-over corresponds to the ratio of the peak areas of the measurement from Sample B to the measurement from Sample A. The smaller this ratio, the smaller the amount of sample carry-over. This ratio can be changed by varying the rinsing time. This can be used to determine the required rinsing time for the application.

## 5.16 Separation column

### 5.16.1 Separating efficiency

The analysis quality that can be attained depends in a large part on the separating efficiency of the separation column being used. The separating efficiency of the selected separation column must be sufficient for the current analysis problems. If difficulties arise, start by checking the quality of the separation column in each case by recording a standard chromatogram.

You can find detailed information on the separation columns available from Metrohm in the leaflet provided along with your separation column, in the **Metrohm IC Column Program** (available from your Metrohm representative) or on the Internet at <http://www.metrohm.com> in the Ion Chromatography product area. You can find information on special IC applications in the corresponding "**Application Bulletins**" or "**Application Notes**", which are available on the Internet at <http://www.metrohm.com> in the Applications area or free of charge upon request from your responsible Metrohm representative.

### 5.16.2 Protecting the separation column

We recommend using the following protective measures so that the separation column retains its separating efficiency for as long as possible:

- Microfilter both the sample and the eluent (0.45 µm filter) and aspirate the eluent via the aspiration filter (6.2821.090) as well.
- Always use a guard column. Information regarding which guard column is suitable for your separation column can be found in the **Metrohm IC Column Program** (which is available from your Metrohm representative), the leaflet provided along with your separation column or the product information about the separation column at <http://www.metrohm.com> (Ion Chromatography product area), or it can be obtained directly from your representative.
- Use the pulsation absorber.

### 5.16.3 Storing the separation column

Always store separation columns you do not need in a sealed and filled state according to the column manufacturer's specifications.

### 5.16.4 Regenerating the separation column

The separation column can be regenerated according to the column manufacturer's specifications if the separation characteristics of the column have deteriorated. You can find information on regenerating separation columns available from Metrohm on the leaflet provided with every column.



**NOTE**

---

Regeneration is intended as a last resort. It should not be carried out regularly.

## 6 Troubleshooting

<b>Problem</b>	<b>Cause</b>	<b>Remedy</b>
<b>Marked drop in pressure.</b>	<i>Leak in the system.</i>	Check the capillary connections and seal leaks, if necessary ( <i>see chapter 3.2, page 14</i> ).
	<i>The eluent is not sufficiently degassed.</i>	Ensure that the connectors for the eluent degasser are firmly connected ( <i>see chapter 5.6, page 64</i> ).
<b>The baseline has a large amount of noise.</b>	<i>The eluent path has a leak.</i>	Check the eluent path and fix the leak. If necessary, tighten the pressure screws using a wrench (6.2739.000).
	<i>High-pressure pump – Contaminated pump valves.</i>	Clean the pump valves ( <i>see chapter 5.8, page 66</i> ).
	<i>The eluent path is blocked.</i>	Check the eluent path and eliminate the blockage.
	<i>Contaminations in the eluent</i>	Check the quality of the chemicals and the water.
	<i>High-pressure pump – Defective piston seals.</i>	Replace the piston seals ( <i>see chapter 5.8, page 66</i> ).
	<i>The pulsation absorber is not connected or is defective.</i>	Connect ( <i>see chapter 3.10, page 27</i> ) or replace the pulsation absorber.
	<i>Thermal equilibrium is not yet attained.</i>	Condition the instrument with the column oven switched on ( <i>see chapter 3.22, page 56</i> ).
<b>The baseline is drifting.</b>	<i>Leak in the system.</i>	Check all capillary connections and seal leaks, if necessary ( <i>see chapter 3.2, page 14</i> ).
	<i>The organic solvent in the eluent is evaporating.</i>	<ul style="list-style-type: none"> <li>▪ Check the eluent bottle cap (<i>see chapter 3.6, page 21</i>).</li> <li>▪ Constantly stir the eluent.</li> </ul>
	<i>The inline filter (6.2821.120) is blocked.</i>	Replace the filter (6.2821.130) .
<b>The pressure in the system markedly increases.</b>	<i>The inline filter (6.2821.120) is blocked.</i>	Replace the filter (6.2821.130) .



<b>Problem</b>	<b>Cause</b>	<b>Remedy</b>
<b>The peristaltic pump is pumping too little.</b>	<i>Peristaltic pump – Contact pressure too weak.</i>	Correctly set the contact pressure (see "Setting the contact pressure correctly", page 41).
	<i>Peristaltic pump – Filter blocked.</i>	Replace the filter (see "Replacing the filter", page 92).
	<i>Peristaltic pump – Pump tubing defective.</i>	Replace the pump tubing (see chapter 5.13.2.1, page 91).
<b>Data of the separation column cannot be read.</b>	<i>Column chip dirty.</i>	Clean the contact surfaces of the column chip with ethanol.
	<i>Column chip is defective.</i>	<ol style="list-style-type: none"> <li>1. Save column configuration in MagIC Net.</li> <li>2. Notify Metrohm Service.</li> </ol>
<b>Individual peaks are greater than expected.</b>	<i>Sample – Sample carry-over from previous measurements.</i>	Check the rinsing time (see "Checking the rinsing time", page 94).
<b>MSM – Insufficient flow of regeneration solution or rinsing solution.</b>	<i>Peristaltic pump – Contact pressure too weak.</i>	Correctly set the contact pressure .
	<i>Peristaltic pump – Filter blocked.</i>	Replace the filter (see chapter 5.13.2.2, page 92).
	<i>Peristaltic pump – Pump tubing defective.</i>	Replace the pump tubing.
<b>The background conductivity is too high.</b>	<i>The MSM is not connected.</i>	Connect the MSM (see chapter 3.12, page 30).
	<i>The incorrect eluent is being used.</i>	Change the eluent (see chapter 5.5.2, page 64).
	<i>MSM – No or insufficient flow of regeneration solution or rinsing solution.</i>	Check the flow of the regeneration solution and of the rinsing solution .
<b>The retention times are poorly reproducible.</b>	<i>The eluent path has a leak.</i>	Check all of the connections along the eluent path and fix the leak.
	<i>The eluent path is blocked.</i>	Check the eluent path and eliminate the blockage.
	<i>The eluent contains gas bubbles.</i>	<ul style="list-style-type: none"> <li>▪ Check the connectors of the eluent degasser .</li> </ul>



<b>Problem</b>	<b>Cause</b>	<b>Remedy</b>
<b>Vacuum is not being built</b>	<i>Eluent degasser – Vacuum connection on the rear of the instrument is not (tightly) sealed.</i>	<ul style="list-style-type: none"><li>▪ Seal the <b>Vacuum</b> connector tightly with a threaded stopper (6.1446.040).</li></ul>



## 7 Technical specifications

### 7.1 Reference conditions

The technical specifications listed in this chapter refer to the following reference conditions:

<i>Ambient temperature</i>	+25 °C (±3 °C)
<i>Instrument status</i>	> 40 minutes in operation

### 7.2 Ambient conditions

#### *Operation*

<i>Nominal function range</i>	+5 to +45 °C at max. 80% relative humidity, non-condensing
-------------------------------	---

<i>Storage</i>	+5 to +45 °C at max. 80% relative humidity, non-condensing
----------------	---

<i>Altitude / Pressure range</i>	max. 3,000 m.a.s.l. sea level / min. 700 mbar
----------------------------------	---

<i>Overvoltage category</i>	II
-----------------------------	----

<i>Pollution degree</i>	2
-------------------------	---

### 7.3 Housing

#### *Dimensions*

*Width* 302 mm

*Height* 562 mm

*Depth* 368 mm

<i>Base tray, housing and bottle holder material</i>	Polyurethane hard foam (PUR) with flame retardation for fire class UL 94 V-0, CFC-free, coated
--	--

<i>IP degree of protection</i>	IP 20
--------------------------------	-------

#### *Controls*

*Indicators* LED for standby indicator

*On/off switch* On the rear of the instrument

## 7.4 Weight

2.930.2360                      25.93 kg (without accessories)

## 7.5 Leak sensor

*Type*                              Electronic, no calibration necessary

## 7.6 Column oven

*Type*                              Resistance heating for thermostating an intelligent column with a length of up to 300 mm.

*Adjustable temperature range*                      +0 - +80 °C, in 0.1 °C increments

*Heating*                              Ambient temperature of +5 °C - ambient temperature of +40 °C

*Temperature reproducibility*                      ±0.2 °C

*Stability*                              < 0.05 °C

*Heating time*                      < 30 minutes from 20 to 40 °C

## 7.7 Eluent degasser

*Material*                              Fluoropolymer

*Resistance to solvents*                      No restriction (except PFC)

*Time to establish vacuum*                      < 60 s



## 7.8 High-pressure pump

<i>Type</i>	<ul style="list-style-type: none"> <li>▪ Serial dual-piston pump</li> <li>▪ Intelligent pump head recognition</li> <li>▪ Chemically inert</li> <li>▪ Metal-free pump heads</li> <li>▪ Materials in contact with the eluent: PEEK, ZrO<sub>2</sub>, PTFE/PE</li> <li>▪ Self-optimizing flow and pressure</li> </ul>
<i>Flow rate</i>	
<i>Adjustable flow range</i>	0.001 - 20 mL/min 0.01 - 5 mL/min with standard PEEK pump head
<i>Flow increment</i>	1 µL/min
<i>Reproducibility of the eluent flow</i>	< 0.1% deviation
<i>Pressure range</i>	
<i>Pump</i>	0 - 50.0 MPa (0 - 500 bar)
<i>Pump head</i>	0 - 35.0 MPa (0 - 350 bar) (applies for the standard PEEK pump head)
<i>Residual pulsation</i>	< 1%
<i>Safety shutdown</i>	
<i>Function</i>	Automatic shutdown upon reaching the pressure limits
<i>Maximum pressure limit</i>	<ul style="list-style-type: none"> <li>▪ Adjustable from 0.1 - 50 MPa (1 - 500 bar)</li> <li>▪ The pump is automatically shut down at the first piston stroke above the maximum limit value</li> </ul>
<i>Minimum pressure limit</i>	<ul style="list-style-type: none"> <li>▪ Adjustable from 0 - 49 MPa (0 - 490 bar)</li> <li>▪ The shutdown mechanism is inactive at 0 MPa</li> <li>▪ The shutdown mechanism becomes active two minutes after system start</li> <li>▪ The pump is automatically shut down after three piston strokes below the minimum pressure limit</li> </ul>

## 7.9 Injection valve

<i>Actuator switching time</i>	typ. 100 ms
<i>Maximum operating pressure</i>	35 MPa (350 bar)
<i>Material</i>	PEEK

## 7.10 Metrohm Suppressor Module (MSM)

<i>Resistance to solvents</i>	No restriction
<i>Switching time</i>	typ. 100 ms

## 7.11 Peristaltic pump

<i>Type</i>	2-channel peristaltic pump
<i>Shift direction</i>	Clockwise/counterclockwise
<i>Rotational speed</i>	0 - 42 rpm in 7 levels of 6 rpm each
<i>Pumping characteristics</i>	0.3 mL/min at 18 rpm; with standard pump tubing (6.1826.420)
<i>Pump tubing material</i>	Recommended: PharMed® (Ismaprene)

## 7.12 Detector

You can find the technical specifications for the detector in the manual for the detector.



## 7.13 Sample degasser

<i>Material</i>	Fluoropolymer
<i>Resistance to solvents</i>	No restriction (except PFC)
<i>Time to establish vacuum</i>	< 60 s

## 7.14 Energy supply

<i>Nominal voltage range</i>	100–240 V ( $\pm$ 10%)
<i>Nominal frequency range</i>	50–60 Hz ( $\pm$ 3%)
<i>Power consumption</i>	<ul style="list-style-type: none"> <li>▪ 65 W for typical analysis application</li> <li>▪ 25 W standby (conductivity detector to 40 °C)</li> </ul>
<i>Power supply unit</i>	<ul style="list-style-type: none"> <li>▪ up to 300 W maximum, electronically monitored</li> <li>▪ internal fuse 3.15 A</li> </ul>

## 7.15 Interfaces

<i>USB</i>	
<i>Input</i>	1 USB upstream, type B (labeled <b>PC</b> for connecting to a computer)
<i>Output</i>	2 USB downstream, type A (labeled <b>USB 1</b> and <b>USB 2</b> )
<i>MSB</i>	2 MSB 8-pin Mini DIN (female) (labeled <b>MSB 1</b> and <b>MSB 2</b> for Dosino, stirrer, remote lines, etc.)
<i>Detector</i>	1 15-pin high-density D-sub (female) (labeled <b>Detector</b> )
<i>Column recognition</i>	for an intelligent column
<i>Leak sensor</i>	1 jack plug (labeled <b>Leak Sensor</b> )
<i>Further connections</i>	
<i>Auxiliary</i>	1 15-pin DSUB (female)
<i>Service</i>	1 15-pin DSUB (female)

## 8 Accessories

Up-to-date information on the scope of delivery and on optional accessories for your instrument can be found on the Internet. You can download this information using the article number as follows:

### Downloading the accessories list

- 1** Type <https://www.metrohm.com/> into your Internet browser.
- 2** Under **Find products, accessories, and applications by**, enter the article number (e.g. **2.930.2360**).  
The search result is displayed.
- 3** Under **Products**, click on **More information**.  
Detailed information regarding the product is shown on various tabs.
- 4** On the **Included parts** tab, click on **Download the PDF**.  
The PDF file with the accessories data will be created.



#### NOTE

When you receive your new instrument, we recommend downloading the accessories list from the Internet, printing it out and keeping it together with the manual for reference purposes.



- Organic contamination  
 Suppressor ..... 84
- Overvoltage category ..... 102
- P**
- 
- Peristaltic pump  
 Installation ..... 38  
 Maintenance ..... 91  
 Mode of operation ..... 42  
 Operation ..... 91  
 Technical specifications ..... 105
- Piston of the high-pressure pump  
 ..... 67
- Piston seal ..... 67
- Power connection ..... 47
- Power consumption ..... 106
- Power supply unit ..... 106
- Precipitate ..... 65
- Pressure increase ..... 65
- Pressure limit ..... 104
- Pressure range ..... 104
- Protection  
 Inline filter ..... 26
- Pulsation ..... 67
- Pulsation absorber  
 Installation ..... 27
- Pump tubing  
 Install ..... 38  
 Service life ..... 91
- Pump tubings  
 Overview ..... 38
- R**
- 
- Reference conditions ..... 102
- Regeneration ..... 59  
 Anion suppressor ..... 84  
 Cation suppressor ..... 86
- Rinse  
 Guard column ..... 52  
 Pump tubing ..... 91  
 Sample path ..... 93  
 Separation column ..... 55
- Rinsing time ..... 94
- S**
- 
- Safety instructions ..... 3
- Safety shutdown ..... 104
- Sample  
 Carry-over ..... 93  
 Sample loop ..... 28  
 Transfer time ..... 93
- Sample degasser  
 Installation ..... 44  
 Technical specifications ..... 106
- Sample loop ..... 28
- Sample path  
 Rinse ..... 93
- Sea level ..... 102
- Separation column  
 Installation ..... 52  
 Protection ..... 2, 27, 95  
 Regeneration ..... 95  
 Rinse ..... 55  
 Separating efficiency ..... 95  
 Storage ..... 95
- Service ..... 4, 59
- Shutting down ..... 60
- Storage ..... 102
- Supply voltage ..... 4
- Suppression rotor  
 see Suppressor ..... 84, 86
- Suppressor  
 Clean ..... 86
- Install rotor ..... 30
- Installation ..... 30
- Maintenance ..... 82
- Operation ..... 82
- Replacing parts ..... 89
- Switching ..... 82
- Technical specifications ..... 105
- Suppressor drive  
 see "Suppressor" ..... 30
- T**
- 
- Technical specifications  
 Detector ..... 106  
 Eluent degasser ..... 103  
 High-pressure pump ..... 104  
 Injection valve ..... 105  
 Interfaces ..... 106  
 Leak sensor ..... 103  
 Peristaltic pump ..... 105  
 Reference conditions ..... 102  
 Sample degasser ..... 106  
 Suppressor ..... 105
- Temperature ..... 102
- Transfer time ..... 93
- Transport locking screws ..... 17
- Tubings  
 Installation ..... 14
- U**
- 
- USB ..... 106
- V**
- 
- Vacuum pump  
 Protection ..... 18
- Valve  
 See also "Injection valve" ..... 28
- Voltage ..... 106