

930 Compact IC Flex



930 Compact IC Flex SeS/PP

Manual

8.930.8009EN / v6 / 2025-04-30



Metrohm AG
CH-9100 Herisau
Switzerland
+41 71 353 85 85
info@metrohm.com
www.metrohm.com

930 Compact IC Flex

930 Compact IC Flex SeS/PP

2.930.1500

Manual

Technical Communication
Metrohm AG
CH-9100 Herisau

This documentation is protected by copyright. All rights reserved.

This documentation is an original document.

This documentation has been prepared with great care. However, errors can never be entirely ruled out. Please send comments regarding possible errors to the address above.

Disclaimer

Deficiencies arising from circumstances that are not the responsibility of Metrohm, such as improper storage or improper use, etc., are expressly excluded from the warranty. Unauthorized modifications to the product (e.g., conversions or attachments) exclude any liability on the part of the manufacturer for resulting damage and its consequences. Instructions and notes in the Metrohm product documentation must be strictly followed. Otherwise, Metrohm's liability is excluded.

Table of contents

1	Introduction	1
1.1	Instrument description	1
1.2	Accessories and additional information	3
1.3	Symbols and conventions	3
2	Safety	5
2.1	Intended use	5
2.2	Responsibility of the operator	5
2.3	Requirements for operating personnel	6
2.4	Safety instructions	6
2.4.1	General notes on safety	6
2.4.2	Electrical safety	6
2.4.3	Tubing and capillary connections	7
2.4.4	Flammable solvents and chemicals	8
2.4.5	Recycling and disposal	8
3	Overview of the instrument	9
3.1	Front	9
3.2	Rear	10
3.3	Feed-throughs for capillaries and cables	12
4	Installation	15
4.1	Setting up the instrument	15
4.1.1	Packaging	15
4.1.2	Checks	15
4.1.3	Location	15
4.2	Capillary connections in the IC system	15
4.3	Removing transport locking screws	18
4.4	Connecting the drainage tubing and leak sensor	19
4.4.1	Installing the drainage tubing	19
4.4.2	Connecting the leak sensor	21
4.5	Connecting the eluent bottle	21
4.6	Installing the high-pressure pump	26
4.7	Installing an inline filter	27
4.8	Installing the pulsation absorber	27
4.9	Injection valve	28



4.10	Metrohm Suppressor Module (MSM)	30
4.10.1	Inserting the rotors	31
4.10.2	Connecting the Metrohm Suppressor Module (MSM)	33
4.11	Peristaltic pump	38
4.11.1	Installing the peristaltic pump	38
4.11.2	Mode of operation for the peristaltic pump	42
4.12	Metrohm CO₂ Suppressor (MCS)	43
4.12.1	General information on the MCS	43
4.12.2	Connecting the MCS	43
4.12.3	Installing the CO ₂ Absorber	45
4.13	Installing the conductivity detector	46
4.14	Installing the amperometric detector	47
4.15	Connecting the instrument to a computer	48
4.16	Connecting the instrument to the power grid	49
4.17	Initial start-up	50
4.18	Connecting and rinsing the guard column	52
4.19	Connecting and rinsing the separation column	54
4.20	Conditioning	57
5	Operation	59
6	Operation and maintenance	60
6.1	IC system	60
6.1.1	Operation	60
6.1.2	Care	60
6.1.3	Maintenance by Metrohm Service	60
6.1.4	Shutting down and recommissioning	61
6.2	Capillary connections	62
6.3	Servicing the door	62
6.4	Handling the eluent	62
6.4.1	Manufacturing eluent	63
6.4.2	Changing the eluent	63
6.5	Notes on operating the high-pressure pump	64
6.6	Servicing the high-pressure pump	64
6.7	Servicing the inline filter	78
6.8	Servicing the pulsation absorber	81
6.9	Injection valve	81
6.10	Metrohm Suppressor Module (MSM)	81
6.10.1	Notes for operating the Metrohm Suppressor Module (MSM)	81
6.10.2	Taking care of the suppressor housing	82

6.10.3	Servicing the Metrohm Suppressor Module (MSM)	82
6.11	Peristaltic pump	90
6.11.1	Notes on operating the peristaltic pump	90
6.11.2	Servicing the peristaltic pump	90
6.12	Maintenance on the Metrohm CO₂ Suppressor (MCS)	92
6.12.1	Replacing the CO ₂ Absorber	92
6.13	Detector maintenance	93
6.14	Rinsing the sample path	93
6.15	Separation column	94
6.15.1	Separating efficiency	94
6.15.2	Protecting the separation column	95
6.15.3	Storing the separation column	95
6.15.4	Regenerating the separation column	95
7	Troubleshooting	96
7.1	96
8	Technical specifications	101
8.1	Reference conditions	101
8.2	Ambient conditions	101
8.3	Housing	101
8.4	Weight	102
8.5	Leak sensor	102
8.6	High-pressure pump	102
8.7	Injection valve	103
8.8	Metrohm Suppressor Module (MSM)	103
8.9	Peristaltic pump	103
8.10	Metrohm CO ₂ Suppressor (MCS)	103
8.11	Detector	104
8.12	Energy supply	104
8.13	Interfaces	104
	Index	105



Table of figures

Figure 1	Front	9
Figure 2	Rear	10
Figure 3	Feed-throughs on the door	12
Figure 4	Openings for capillaries and cables	13
Figure 5	Ducts for capillaries	14
Figure 6	Removing the transport locking screws	18
Figure 7	Installing the eluent bottle cap	22
Figure 8	Installing the tubing weighting and aspiration filter	24
Figure 9	High-pressure pump with purge valve	26
Figure 10	Inline filter	27
Figure 11	Pulsation absorber	28
Figure 12	Exchanging the sample loop	29
Figure 13	Metrohm Suppressor Module (MSM) – Connection capillaries	34
Figure 14	Peristaltic pump	42
Figure 15	Connecting the MCS	44
Figure 16	High-pressure pump – Parts	65
Figure 17	High-pressure pump – Cross-section	72
Figure 18	Tool for piston seal (6.2617.010)	73
Figure 19	Removing the piston cartridge from the pump head	73
Figure 20	Inserting the piston seal into the tool	74
Figure 21	Parts of the piston cartridge	75
Figure 22	Inline filter – Removing the filter	79
Figure 23	Parts of the Metrohm Suppressor Module (MSM)	82
Figure 24	Pump tubing connection – Replacing the filter	91

1 Introduction

1.1 Instrument description

The 930 Compact IC Flex is a robust ion chromatograph. It is distinguished by:

- Its intelligence: All of the functions are monitored, optimized and documented in an FDA-compatible manner. Intelligent components, such as iColumns, save important data onto a chip.
- Its compact design: It has a small footprint.
- Its transparency: All components are easily accessible and located for simple visibility and can be monitored during operation through a large window.
- Its safety: The wet end and the electronics are physically separated, thereby preventing fluids from coming into contact with the electronics to a large extent. A leak sensor is integrated into the wet end.
- Its environmental compatibility.
- Its low noise emission.
- The intelligent MagIC Net software.

The 930 Compact IC Flex is operated using the MagIC Net software. A USB cable is used to connect the instrument to a computer with MagIC Net installed. The intelligent software detects the instrument automatically and checks its functionality. The software controls and monitors the instrument, evaluates the measured data and manages it in a database.

The 930 Compact IC Flex SeS/PP consists of the following modules:

Housing

The sturdy housing contains the instrument's electronic components, including their interfaces and one connector for a separation column. In addition, the housing provides space for a conductivity detector or an amperometric detector. Capillaries and cables can be fed into and out of the instrument through several openings.

Leak sensor

The leak sensor detects leaking liquid that collects in the instrument's base tray. Liquid that leaks in the instrument is routed to the base tray using drainage tubing and detected there.

High-pressure pump

The intelligent and low-pulsation high-pressure pump pumps the eluent through the IC system. It is equipped with a chip where its technical

are equipped with a chip where their technical specifications and history (start-up, operating hours, injections etc) are stored.

1.2 Accessories and additional information

Additional information is available on the Metrohm website (<https://www.metrohm.com>):

- Product family
- Product versions
- Accessories
- Documents about the product

Downloading the accessories list



NOTE

The accessories list is a part of the product documentation. Download the accessories list and store it as a reference.

1. Use the search function to search for the product.
2. Open the desired product version.
3. Download the accessories list.

1.3 Symbols and conventions

The following symbols and formatting may appear in this documentation:

(5-12)	Cross-reference to figure legend The first number refers to the figure number, the second to the instrument part in the figure.
1	Instruction step Perform the steps one after the other.
Method	Dialog text, parameter in the software
File ► New	Menu or menu item
[Continue]	Button or key
	WARNING This symbol draws attention to a possible life-threatening hazard or risk of injury.



WARNING

This symbol draws attention to a possible hazard due to electrical current.



WARNING

This symbol draws attention to a possible hazard due to heat or hot instrument parts.



WARNING

This symbol draws attention to a possible biological hazard.



WARNING

Warning of optical radiation



CAUTION

This symbol draws attention to possible damage to instruments or instrument parts.



NOTICE

This symbol highlights additional information and tips.

2 Safety

2.1 Intended use

The 930 Compact IC Flex SeS/PP is used for the determination of anions, cations or polar substances with sequential suppression using ion chromatography.

Sequential suppression consists of:

- Chemical suppression with a Metrohm Suppressor Module (MSM) and subsequent
- CO₂ suppression with the Metrohm CO₂ Suppressor (MCS).

Background conductivity is reduced to a minimum with sequential suppression.

The instrument can also be used as needed for the determination of cations, polar substances or anions without suppression.

This instrument is suitable for processing chemicals and flammable samples. Therefore, the use of the 930 Compact IC Flex requires the user to have basic knowledge and experience in handling toxic and caustic substances. Knowledge regarding the application of fire prevention measures prescribed for laboratories is also mandatory.

2.2 Responsibility of the operator

The operator must ensure that basic regulations on occupational safety and accident prevention in chemical laboratories are observed. The operator has the following responsibilities:

- Instruct personnel in the safe handling of the product.
- Train personnel in the use of the product according to the user documentation (e.g. install, operate, clean, eliminate faults).
- Train staff on basic occupational safety and accident prevention regulations.
- Provide personal protective equipment (e.g. protective glasses, gloves).
- Provide suitable tools and equipment to carry out the work safely.

The product may be used only when it is in perfect condition. The following measures are required to ensure the safe operation of the product:

- Check the condition of the product before use.
- Remedy defects and malfunctions immediately.
- Maintain and clean the product regularly.

2.3 Requirements for operating personnel

Only qualified personnel may operate the product. Qualified personnel are persons who meet the following requirements:

- Basic regulations on occupational safety and accident prevention for chemical laboratories are known and complied with.
- Knowledge of handling hazardous chemicals is present. Personnel have the ability to recognize and avoid potential dangers.
- Knowledge regarding the application of fire prevention measures for laboratories is available.
- Safety-relevant information is communicated and understood. The personnel can operate the product safely.
- The user documentation has been read and understood. The personnel operate the product according to the instructions in the user documentation.

2.4 Safety instructions

2.4.1 General notes on safety



WARNING

Operate this instrument only according to the information contained in this documentation.

This instrument left the factory in a flawless state in terms of technical safety. To maintain this state and ensure non-hazardous operation of the instrument, the following instructions must be observed carefully.

2.4.2 Electrical safety

The electrical safety when working with the instrument is ensured as part of the international standard IEC 61010.



WARNING

Only personnel qualified by Metrohm are authorized to carry out service work on electronic components.



WARNING

Never open the housing of the instrument. The instrument could be damaged by this. There is also a risk of serious injury if live components are touched.

There are no parts inside the housing which can be serviced or replaced by the user.

Supply voltage



WARNING

An incorrect supply voltage can damage the instrument.

Only operate this instrument with a supply voltage specified for it (see rear panel of the instrument).

Protection against electrostatic charges



WARNING

Electronic components are sensitive to electrostatic charges and can be destroyed by discharges.

Do not fail to pull the power cord out of the power socket before you set up or disconnect electrical plug connections at the rear of the instrument.

The device is to be operated only with the door closed.

2.4.3 Tubing and capillary connections



CAUTION

Leaks in tubing and capillary connections are a safety risk. Tighten all connections well by hand. Avoid applying excessive force to tubing connections. Damaged tubing ends lead to leakage. Appropriate tools can be used to loosen connections.

Check the connections regularly for leakage. If the instrument is used mainly in unattended operation, then weekly inspections are mandatory.

2.4.4 Flammable solvents and chemicals



WARNING

All relevant safety measures are to be observed when working with flammable solvents and chemicals.

- Set up the instrument in a well-ventilated location (e.g. fume cupboard).
- Keep all sources of flame far from the workplace.
- Clean up spilled liquids and solids immediately.
- Follow the safety instructions of the chemical manufacturer.

2.4.5 Recycling and disposal

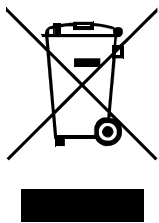

Properly dispose of chemicals and of the product to reduce negative effects on the environment and public health. Local authorities, waste disposal companies or dealers provide more detailed information on disposal. Observe the WEEE EU directive (WEEE = Waste Electrical and Electronic Equipment) for the proper disposal of waste electronic equipment within the European Union.

3 Overview of the instrument

3.1 Front

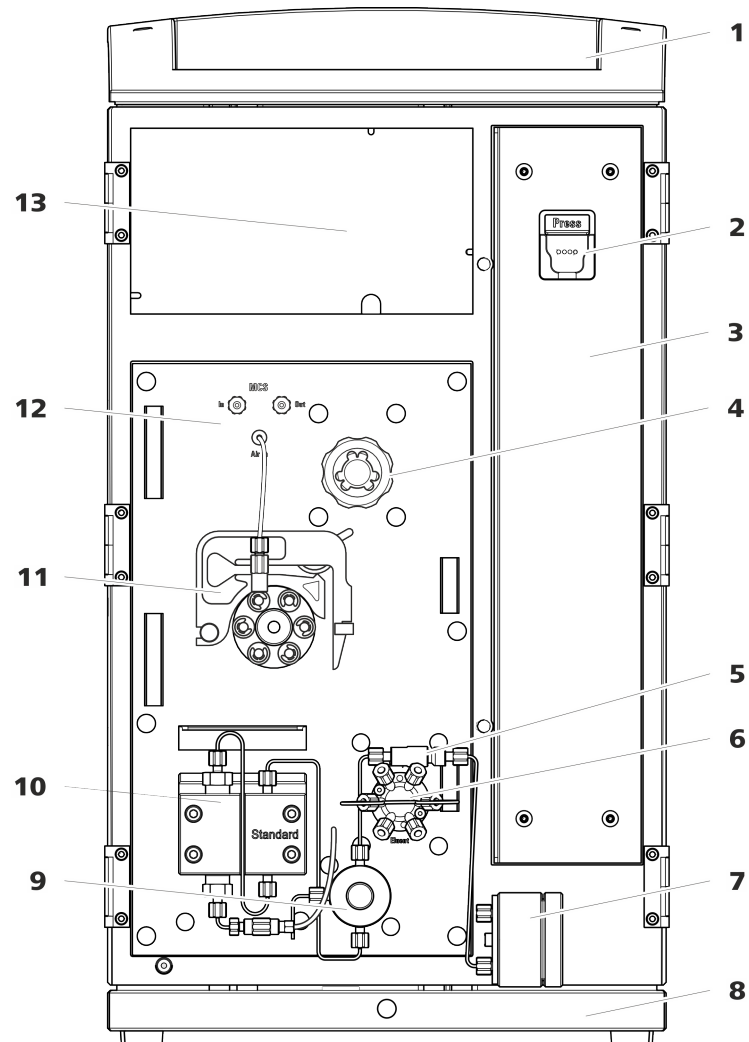

Figure 1 Front

1	Bottle holder	2	Column holder For hanging the separation column (iColumn). With column recognition.
3	Column chamber	4	Metrohm Suppressor Module (MSM)
5	Inline filter	6	Injection valve
7	Pulsation absorber	8	Base tray
9	Purge valve	10	High-pressure pump



11 Peristaltic pump

13 Detector chamber
Room for the detector and the adsorption cartridge for the MCS.

12 Metrohm CO₂ Suppressor (MCS)

3.2 Rear

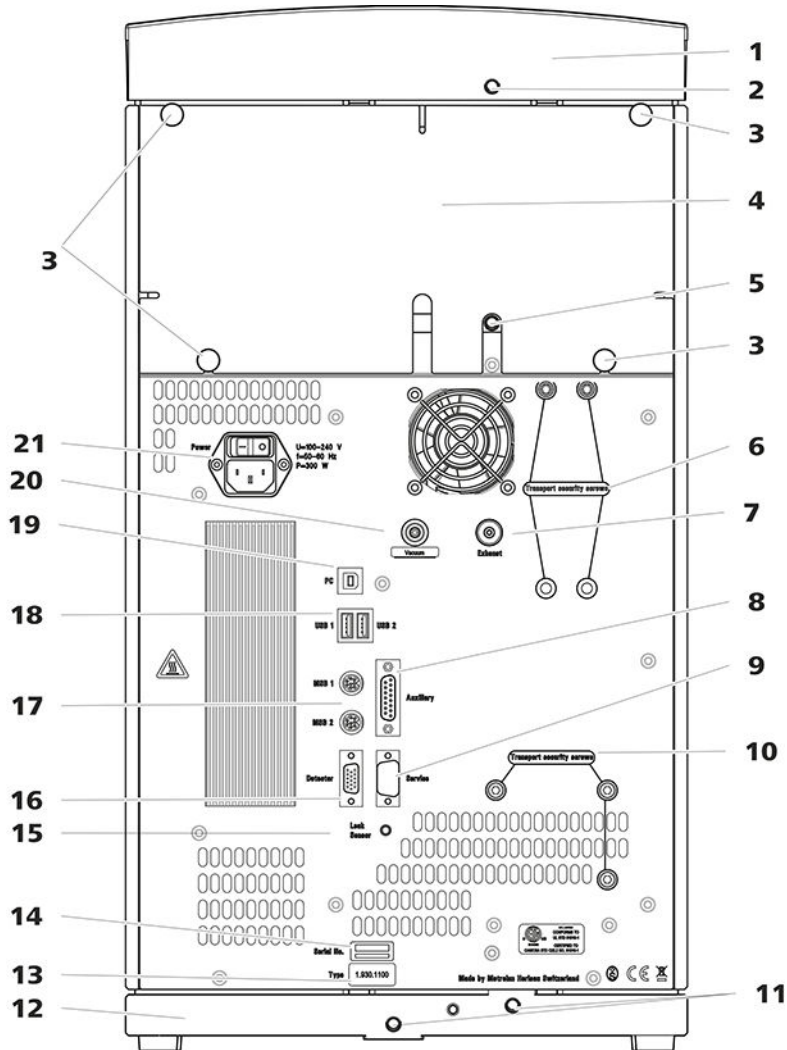

Figure 2 Rear

1 Bottle holder

3 Knurled screws
For fastening the removable back panel.

2 Drainage tubing connection
For connecting the drainage tubing, which guides escaped fluids away from the bottle holder.

4 Back panel
Removable. Enables access to the detector chamber.

- | | |
|---|--|
| <p>5 Drainage tubing connection
For connecting the drainage tubing, which guides escaped liquids away from the detector chamber.</p> <p>7 Exhaust opening
Labeled <i>Exhaust</i>. For extracting the air from the vacuum chamber.</p> <p>9 Service connection socket
For Metrohm service only.</p> <p>11 Drainage tubing connections
For connecting two drainage tubings that guide the escaped fluid to the leak sensor and from there to the waste container.</p> <p>13 Type plate</p> <p>15 Leak sensor connection socket
Labeled <i>Leak Sensor</i>. For connecting the leak sensor connection cable.</p> <p>17 MSB connection sockets
Labeled <i>MSB 1</i> and <i>MSB 2</i>. For connecting MSB devices.</p> <p>19 PC connection socket
For connecting the instrument to the computer with the USB cable (6.2151.020).</p> <p>21 Power socket
Power socket for connecting the power cable and power switch for switching the instrument on and off.</p> | <p>6 Transport locking screws
For securing the vacuum pump when transporting the instrument.</p> <p>8 Auxiliary connection socket
For connecting an 891 Professional Analog Out (2.891.0010).</p> <p>10 Transport locking screws
For securing the high-pressure pump when transporting the instrument.</p> <p>12 Base tray
With leak sensor.</p> <p>14 Serial number</p> <p>16 Detector connection socket
Labeled <i>Detector</i>. For connecting Metrohm detectors.</p> <p>18 USB connection sockets
Labeled <i>USB 1</i> and <i>USB 2</i>. For connecting USB devices.</p> <p>20 Vacuum connection
Plugged with a stopper.</p> |
|---|--|

Openings on the back panel

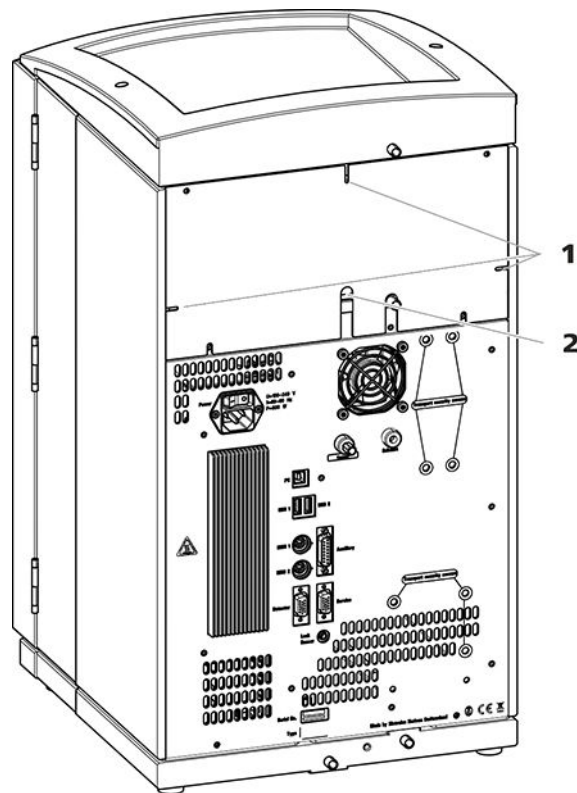

Figure 4 Openings for capillaries and cables

1 Openings for capillaries

2 Openings for cables

The removable back panel is outfitted with openings through which capillaries and cables can be lead out of the detector chamber.

Ducts for capillaries

There are ducts for capillaries between the instrument and base tray as well as between the instrument and the bottle holder. The capillaries can be fed to the front of the instrument from both sides of the instrument and from the front of the instrument to the back of the instrument.

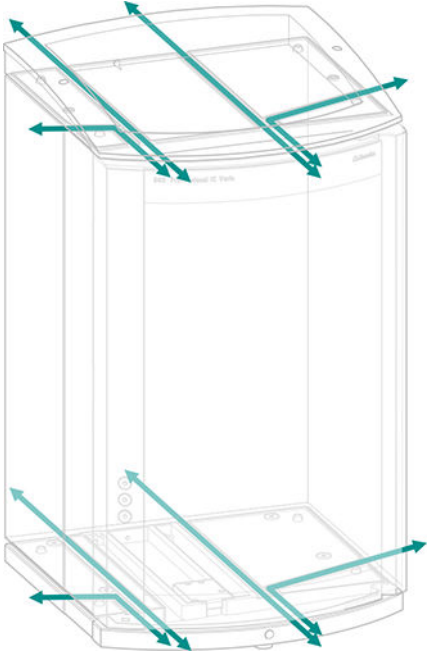

Figure 5 Ducts for capillaries

4 Installation

4.1 Setting up the instrument

4.1.1 Packaging

The instrument is supplied in protective packaging together with the separately packed accessories. Keep this packaging, as only this ensures safe transportation of the instrument.

4.1.2 Checks

Immediately after receipt, check whether the shipment has arrived complete and without damage by comparing it with the delivery note.

4.1.3 Location

The instrument has been developed for operation indoors and may not be used in explosive environments.

Place the instrument in a location of the laboratory which is suitable for operation and free of vibrations and which provides protection against corrosive atmosphere and contamination by chemicals.

The instrument should be protected against excessive temperature fluctuations and direct sunlight.

4.2 Capillary connections in the IC system

Generally speaking, capillary connections between 2 components of an IC system are made up of one connection capillary and 2 pressure screws used to connect the capillary to the respective components.

Pressure screws

Three types of pressure screws are used in the IC system:

Number	Designation	Use
6.2744.010 / 6.2744.014	Pressure screw	On the injection valve
6.2744.070	Pressure screw, short	High-pressure pump, purge valve, inline filter, pulsation absorber, separation columns
6.2744.090	Pressure screw, long	MCS, sample degasser, 10-port valve

Pressure screws are tightened and loosened by hand. A tool is not needed.

Also see: *PEEK pressure screws 1x1* video on the Internet <http://ic-help.metrohm.com>.

Connection capillaries

PEEK capillaries and PTFE capillaries are used in the IC system.

PEEK capillaries (polyetheretherketone)

PEEK capillaries are pressure-stable up to 400 bar (depending on the inner diameter), flexible, chemically inert and have an extremely smooth surface. They can be readily cut down to the desired length with the capillary cutter (6.2621.080).

Use:

- PEEK capillaries with an inner diameter of 0.25 mm (6.1831.010) for the entire high-pressure section.
- PEEK capillaries with an inner diameter of 0.5 mm (6.1831.180) for the sample path.

PTFE capillaries (poly(tetrafluoroethylene))

PTFE capillaries are transparent and enable visual tracing of the liquids to be pumped. They are chemically inert, flexible and temperature-resistant up to 80 °C. They can be readily cut down to the desired length with the capillary cutter (6.2621.080).

Use:

PTFE capillaries (6.1803.0x0) are used for the low-pressure section.

- PTFE capillaries with an inner diameter of 0.5 mm for sample processing and for the transfer of rinsing solutions (they are not necessarily included in the scope of delivery of the instrument).

Capillary connections



NOTE

Sprays of chemicals caused by capillaries slipping out

If you work with an increased system pressure (> 15 MPa), capillaries may slip out of the pressure screws. This can lead to sprays of chemicals.

To avoid this, we recommend

- degreasing the ends of the capillaries before installing them. Dampen a cloth with acetone and wipe off the ends of the capillaries before connecting them with the pressure screws.
- tightening the pressure screws firmly using a wrench (6.2739.000).

In order to achieve optimum analysis results, capillary connections in an IC system must be absolutely tight and free of dead volume. Dead volume

occurs if 2 capillary ends connected to each other do not fit exactly, thus allowing liquid to escape. There are 2 possible causes for this:

- The capillary ends do not have exactly flat edges.
- The two capillary ends do not completely meet.

One prerequisite for dead-volume-free capillary connection is that both capillary ends are cut exactly flat. Therefore we recommend cutting PEEK capillaries only with a capillary cutter (6.2621.080).

Also see: *Cutting capillaries* video on the Internet <http://ic-help.metrohm.com>.

Creating dead-volume-free capillary connections

To create dead-volume-free capillary connections, proceed as follows:

- 1** Wipe off the end of the capillary with a cloth dampened with acetone.
- 2** Slide the pressure screw over the capillary. Ensure that the capillary protrudes 1 to 2 mm from the tip of the pressure screw.
- 3** Push the capillary into the connection or coupling as far as it will go and hold it there.
- 4** Only then start turning the pressure screw. Hold the capillary in the stop position while turning it shut.

Colored sleeves for PEEK capillaries

The enclosed set of varicolored sleeves for PEEK capillaries (6.2251.000) serves to easily differentiate the various flows of liquid in the system through color coding. Each capillary conveying a given liquid (e.g. eluent) can be marked with sleeves of the same color.

- 1** Slide a colored sleeve of a selected color over a capillary and move it to an easily visible position.
- 2** Heat the colored sleeve, e.g. with a hairdryer.

The colored sleeve shrinks and adapts to the shape of the capillary.



NOTE

In order to arrange capillaries more clearly, they can be bundled with the spiral band (6.1815.010).

4.3 Removing transport locking screws

To avoid damage to the drives for the high-pressure pump and the vacuum pump during transport, the pumps are secured with transport locking screws. These are located at the rear of the instrument and labeled with **Transport security screws**.

Remove these transport locking screws before the initial start-up.

Accessories

For this step you need:

- 4 mm hex key (6.2621.030)

Removing the transport locking screws

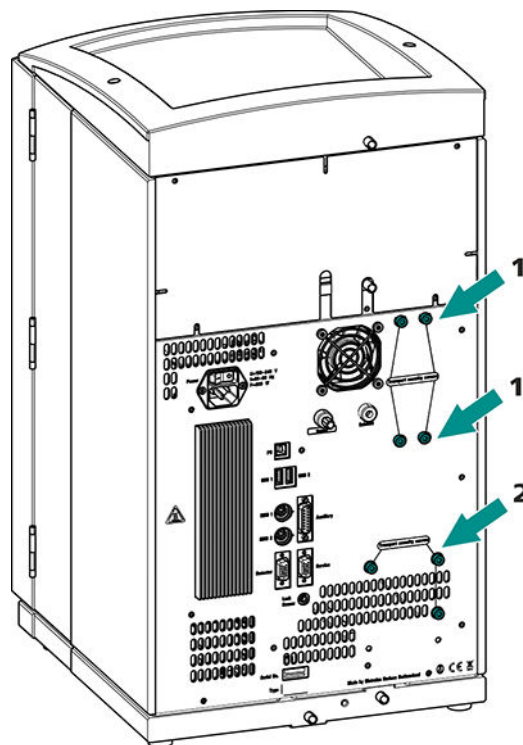

Figure 6 Removing the transport locking screws

1 Transport locking screws

For the vacuum pump. Only present if the instrument has a degasser or a CO₂ Suppressor (MCS).

2 Transport locking screws

For the high-pressure pump.

- 1 Remove all of the transport locking screws with the hex key.

Store the transport locking screws in a safe place. Reinsert the transport locking screws each time you transport the instrument a significant distance.



CAUTION

The pumps may be damaged if you transport the instrument without inserting the transport locking screws.

4.4 Connecting the drainage tubing and leak sensor

The leak sensor detects leaking liquid that collects in the instrument's base tray. Liquid that leaks in the bottle holder or in the detector chamber is conveyed to the base tray using drainage tubing and is detected there.

If the leak sensor detects a leak in the IC system, the IC instrument is switched off. The software displays a warning.

The leak sensor functions properly only if the following preconditions are met:

- The drainage tubing is connected.
- The leak sensor connection cable is inserted into the leak sensor connection socket.
- The 930 Compact IC Flex is switched on.
- The leak sensor is switched to **active** in the software.

4.4.1 Installing the drainage tubing

Liquid that leaks in the bottle holder or detector chamber flows to the rear of the instrument. Openings on the bottle holder and in the detector chamber allow the liquid to drain. The drainage tubing has to be mounted at these openings. This drainage tubing guides the leaking liquid to the base tray where the leak sensor is located.

Accessories

For this step you need the following parts from the accessory kit: Vario/Flex Basic (6.5000.000):

- 2 × silicone tubing (6.1816.020)
- Y connector (6.1807.010)

You also need scissors.



Connecting the drainage tubing

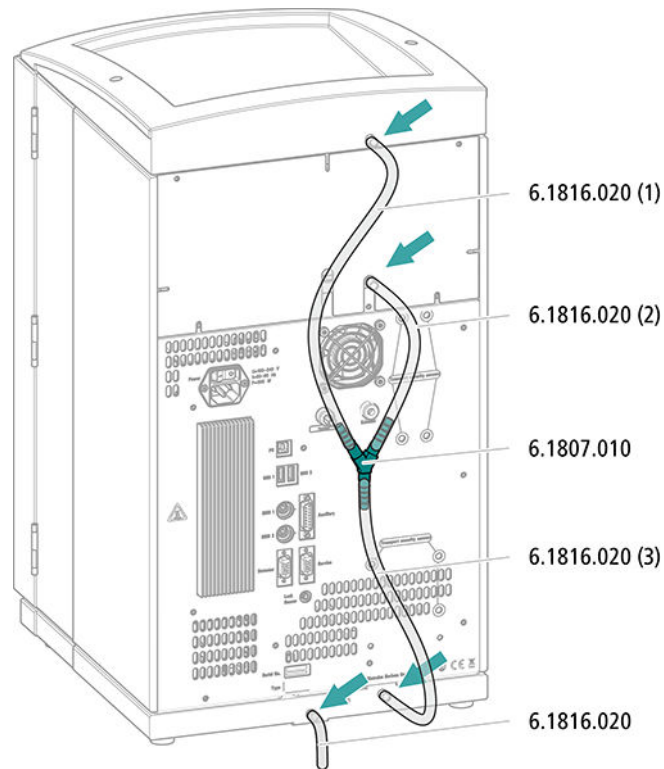

- 1** Cut a piece of silicone tubing into three pieces using scissors: 2 × approx. 40 cm and 1 × 20 cm.
- 2** Attach one end of the 40 cm long piece to the drainage tubing connection on the bottle holder.
- 3** Attach one end of the 20 cm long piece to the drainage tubing connection on the detector chamber.
- 4** Attach each of the loose ends of both pieces of silicone tubing to one end of the Y connector.
- 5** Attach one end of the second 40 cm long piece to the third end of the Y connector.
Attach the loose end to the right-side drainage tubing connection on the base tray.
- 6** Attach one end of the second piece of silicone tubing to the left-side drainage tubing connection on the base tray.

Route the loose end into a waste container.

4.4.2 Connecting the leak sensor

Plugging in the leak sensor connection cable

The leak sensor connection cable is coiled up in the base tray.

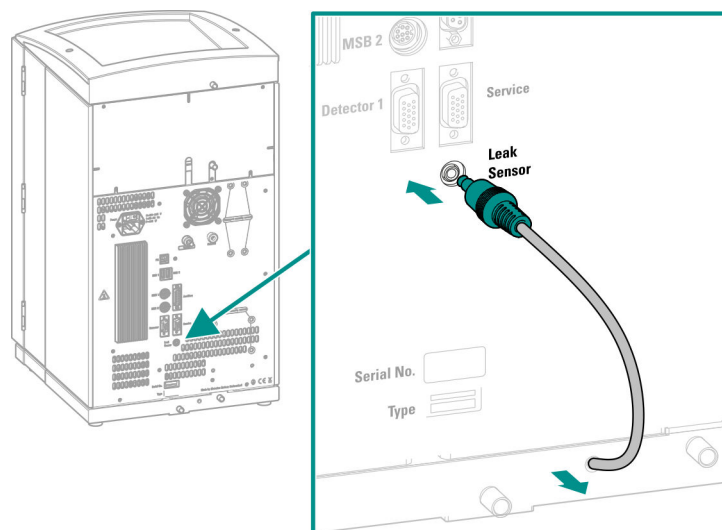

- 1 Pull the leak sensor connection cable out of the base tray as far as needed.
- 2 Plug the plug for the leak sensor connection cable into the leak sensor connection socket (labeled **Leak Sensor**).

4.5 Connecting the eluent bottle

The eluent is aspirated out of the eluent bottle via the eluent aspiration tubing. The eluent aspiration tubing is installed on the entry to the high-pressure pump.

The tubing must be fed out of the instrument through a suitable opening (see "Openings on the back panel", page 13) before the loose end can be connected to the eluent bottle.

Accessories

For this step, you need the following accessories:

These parts are part of the *Vario/Flex ONE* accessory kit (6.5000.010).

- Eluent bottle (6.1608.070)



- The *eluent bottle cap GL 45* accessory set (6.1602.160)
This accessory set contains the bottle cap, an M6 tubing nipple, an M8 tubing nipple, two O-rings and an M6 and M8 threaded stopper.
- The *tubing adapter for aspiration filter* accessory set (6.2744.210)
This accessory set contains a filter holder, a clamping screw and tubing weighting.
- An aspiration filter (6.2821.090)
- The adsorber tube (6.1609.000)
- The SGJ clip (6.2023.020)

Connecting the eluent aspiration tubing

1 Installing the eluent bottle cap (6.1602.160)

- Start by pushing the M8 tubing nipple onto the loose end of the eluent aspiration tubing, followed by the O-ring.
- Push the loose end of the eluent aspiration tubing through the M8 opening of the bottle cap and screw it on for the time being.

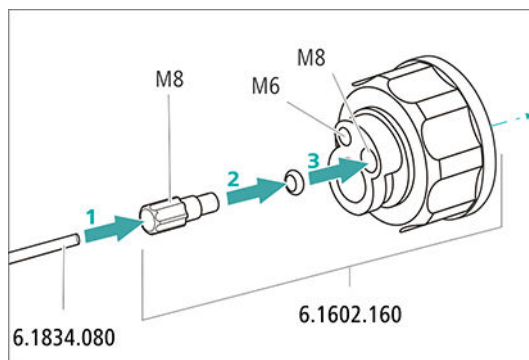

Figure 7 Installing the eluent bottle cap

2 Mounting the tubing adapter

Install the parts of the *tubing adapter for aspiration filter* (6.2744.210) accessory set:

- Start by pushing the tubing weighting onto the loose end of the eluent aspiration tubing.
- Then push the clamping screw onto the loose end of the eluent aspiration tubing.
- Lastly, push the filter holder onto the loose end of the eluent aspiration tubing and screw it onto the tubing nipple.
The end of the tubing should extend approximately 1 cm.

3 Pre-rinsing the aspiration filter



NOTE

Always wear gloves when handling the aspiration filter.

In order to avoid air bubbles after the installation of the aspiration filter, we recommend pre-rinsing the aspiration filter with ultrapure water or eluent.

For pre-rinsing, you will need the adapter Luer inner, M6 outer (6.02744.050), a syringe and a vessel with ultrapure water or eluent.

- Screw the adapter to the aspiration filter.
- Insert the syringe into the adapter.

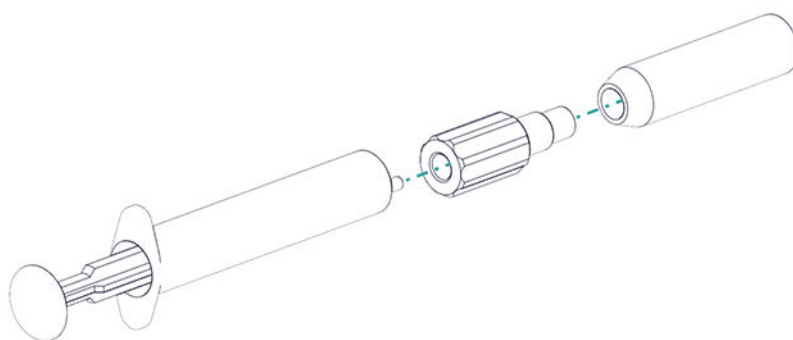

- Immerse the aspiration filter in a vessel with ultrapure water or eluent.
- Fill the syringe completely with ultrapure water or eluent 3 times and then empty it again each time.

4 Mounting the aspiration filter



NOTE

Always wear gloves when handling the aspiration filter.

- Place the loose end of the eluent aspiration tubing into the aspiration filter.
The end of the tubing should reach approximately to the center of the aspiration filter.
- Tighten the aspiration filter to the filter holder.

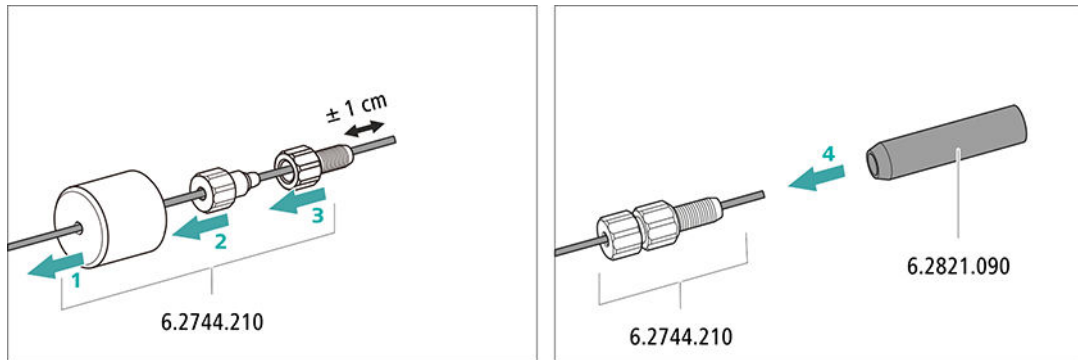
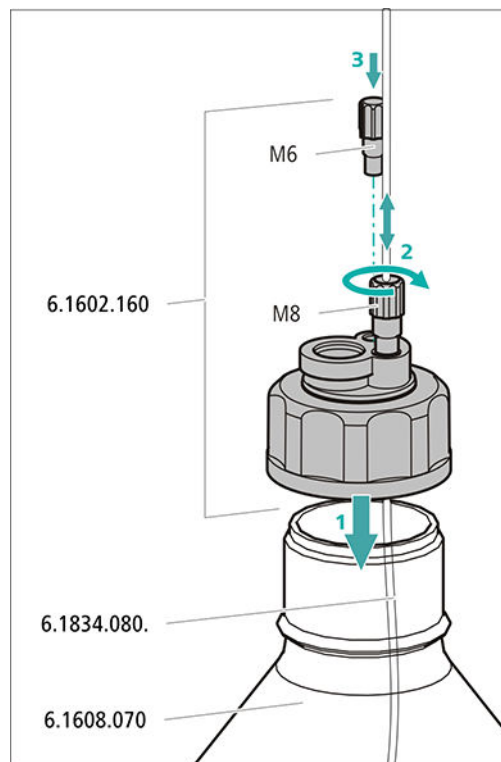

Figure 8 Installing the tubing weighting and aspiration filter

5 Installing the eluent bottle cap on the eluent bottle

- Insert the eluent aspiration tubing into the eluent bottle (6.1608.070).
- Tighten the bottle cap on the eluent bottle.
- Adjust the length of the eluent aspiration tubing so that the aspiration filter is at the bottom of the eluent bottle. Then fix it in place using the M8 tubing nipple.
- Seal the M6 opening on the bottle cap with the M6 threaded stopper from the accessory set.



6 Mounting the adsorber tube



NOTE

Depending on the eluent used, the adsorber tube (6.1609.000) must be filled differently:

- For alkaline eluents or eluents with a low buffer capacity: first a little cotton, then with CO₂ absorber material.
 - For all other eluents: Only with cotton.
- Remove the plastic cover from the large opening of the adsorber tube. Fill the adsorber tube and close it again using the plastic cover.
 - Insert the adsorber tube into the bottle cap's large opening. Fasten it to the bottle cap using the ground-joint clip (6.2023.020).

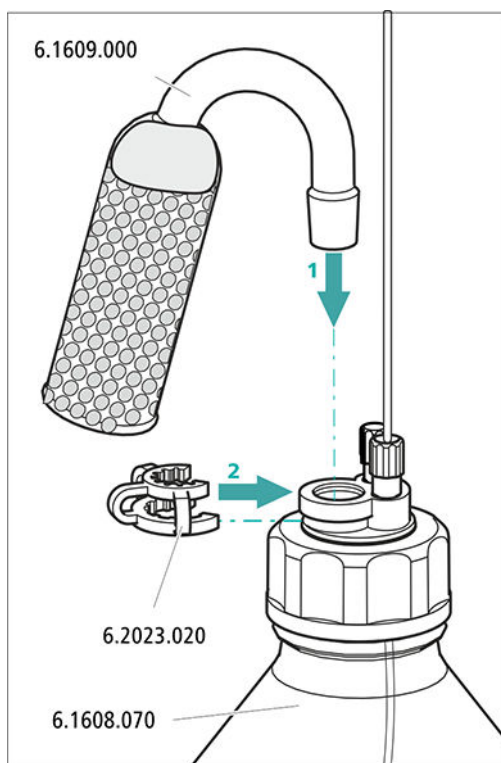



4.6 Installing the high-pressure pump

The intelligent and low-pulsation high-pressure pump pumps the eluent through the system. It is equipped with a chip where its technical specifications and "life history" (operating hours, service data, etc.) are stored.

The high-pressure pump consists of:

- The pump head, which pumps the eluent through the system.
- The purge valve used for bleeding the pump head.

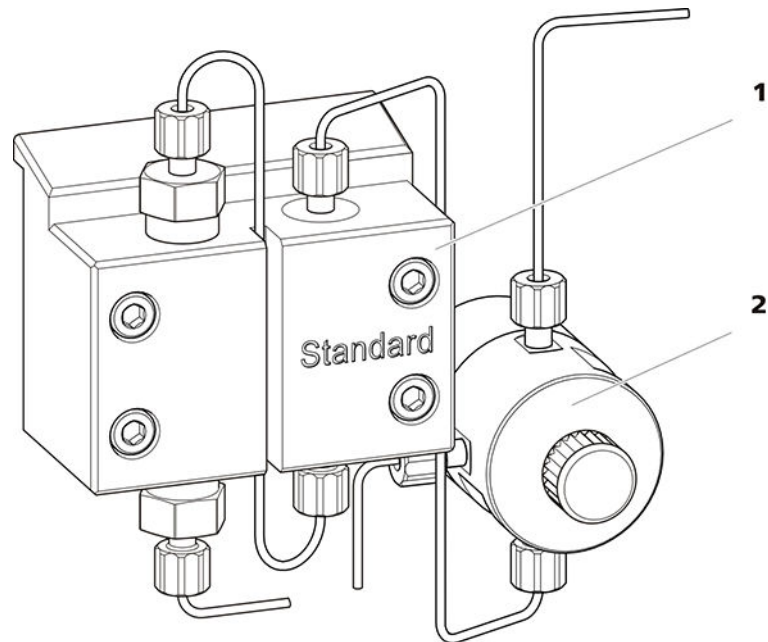

Figure 9 High-pressure pump with purge valve

1 Pump head

2 Purge valve

The high-pressure pump is completely connected. No installation work is required.

4.7 Installing an inline filter

Inline filters protect the separation column reliably from potential contamination from the eluent. The small filter pads with 2 µm pore size can be replaced quickly and easily. They remove particles from the solutions.

An inline filter (6.2821.120) is installed between the purge valve and the pulsation absorber as protection against particles.

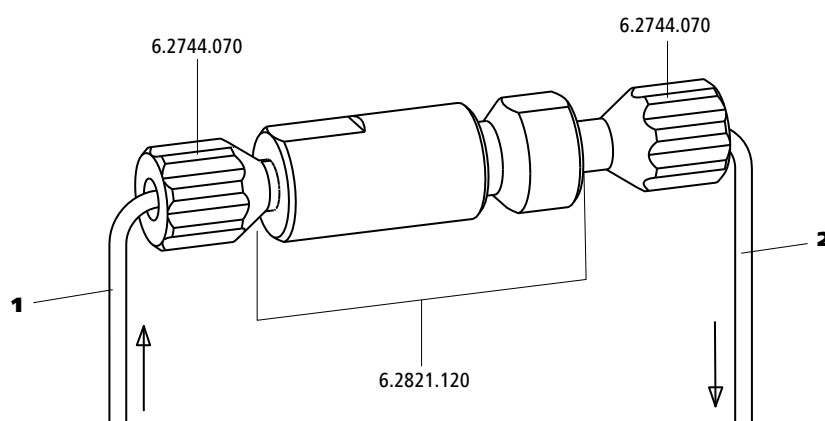

Figure 10 Inline filter

1 Inlet capillary

Connected to the purge valve.

2 Outlet capillary

Connected to the pulsation absorber.

The inline filter is completely connected. No installation work is required.

4.8 Installing the pulsation absorber

The pulsation absorber is installed between the high-pressure pump and the injection valve. It protects the separation column from damage caused by pressure fluctuations, e.g. when the injection valve is switched, and reduces interfering pulsations during highly sensitive measurements.

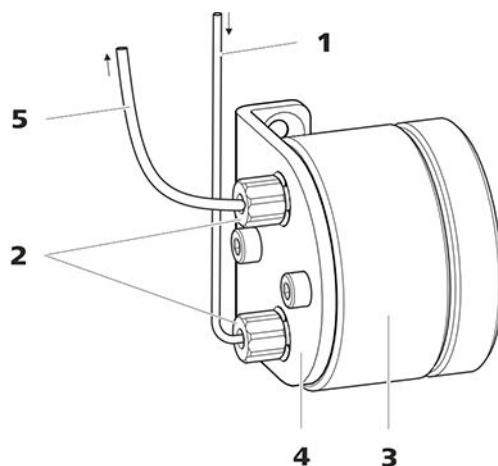

Figure 11 Pulsation absorber

1	Connection capillary Connection to inline filter.	2	PEEK pressure screws, short (6.2744.070)
3	Pulsation absorber (6.2620.150)	4	Holder for pulsation absorber
5	Connection capillary Connection to injection valve.		

The pulsation absorber is completely connected. No installation work is required.

4.9 Injection valve

The injection valve connects the eluent path to the sample path. By a quick and precise switching of the valve a defined quantity of sample solution is injected and flushed to the separation column with the eluent.

The quantity of sample solution injected is determined by:

- the volume of the sample loop or
- by an 800 Dosino when the Metrohm intelligent Partial Loop Injection Technique (MiPT) is used.

The choice of sample loop depends on the application. The following sample loops are normally used:

Table 1 Which sample loop do I need?

Application	Sample loop
Cation determination	20 µL
Anion determination with suppression	20 µL
Anion determination without suppression	100 µL
MiPT	250 µL

The injection valve is completely connected. No installation work is required.

Optional: Exchanging the sample loop

The sample loop can be replaced to match the application (see table 1, page 28).



NOTE

Only use PEEK pressure screws (6.2744.010) to connect capillaries and the sample loop to the injection valve.

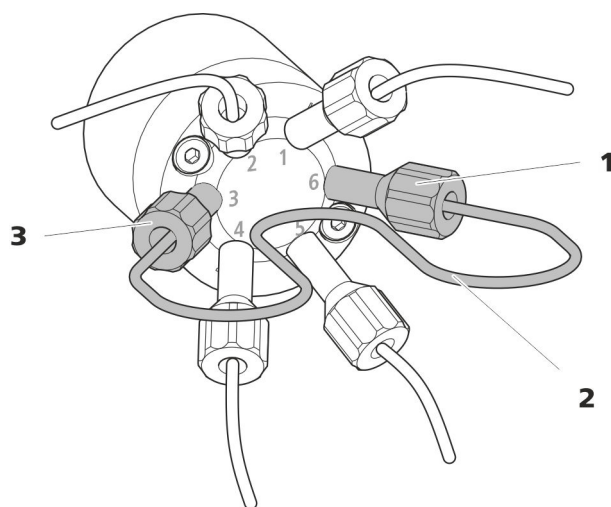

Figure 12 Exchanging the sample loop

1 Pressure screw
Fastened to Port 6.

2 Sample loop

3 Pressure screw
Fastened to Port 3.

Exchanging the sample loop



NOTE

Observe a dead-volume-free installation of the sample loop (see "Creating dead-volume-free capillary connections", page 17).

1 Removing the existing sample loop

- Loosen the pressure screws (6.2744.010) at Port 3 and Port 6.
- Remove the sample loop.



2 Installing a new sample loop

- Fasten one end of the sample loop to Port 3 using a PEEK pressure screw (6.2744.010).
- Use the second PEEK pressure screw (6.2744.010) to fasten the other end of the sample loop to Port 6.

4.10 Metrohm Suppressor Module (MSM)

The suppressor drive of the 930 Compact IC Flex can hold various rotors. The large rotors, such as the MSM-HC Rotor A (6.2842.000) and the MSM-HC Rotor C (6.2842.200) can be inserted directly.

The small rotors, such as the MSM Rotor A (6.2832.000) and the MSM-LC Rotor A (6.2844.000), must first be fitted into the adapter (6.2842.020), which can then be inserted into the suppressor housing.

A connecting piece (6.2835.010) is used for all rotors for connecting the Metrohm Suppressor Module (MSM) to the IC system.

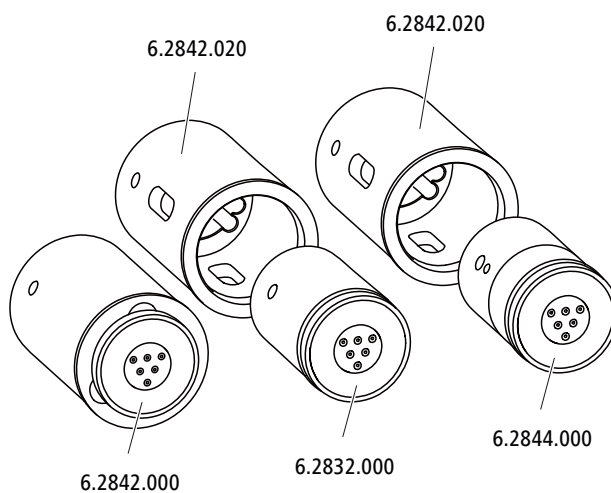

NOTE

The instruments are supplied without rotor and without adapter. The suitable rotor and the adapter, if required, must be ordered separately.

4.10.1 Inserting the rotors

Accessories

For this step, you need the following accessories:

- For suppression: MSM Rotor A (6.2832.000) or MSM-HC Rotor A (6.2842.000), MSM-LC Rotor A (6.2844.000) or MSM-HC Rotor C (6.2842.200) or MSM-HC Rotor C (6.2842.200)
- Optional: Adapter (6.2842.020)
- Connecting piece (6.2835.010)

Large rotors can be inserted directly into the rotor housing.



CAUTION

The rotor may be destroyed during start-up if not inserted correctly. Therefore, follow the following instructions exactly.

Inserting large rotors

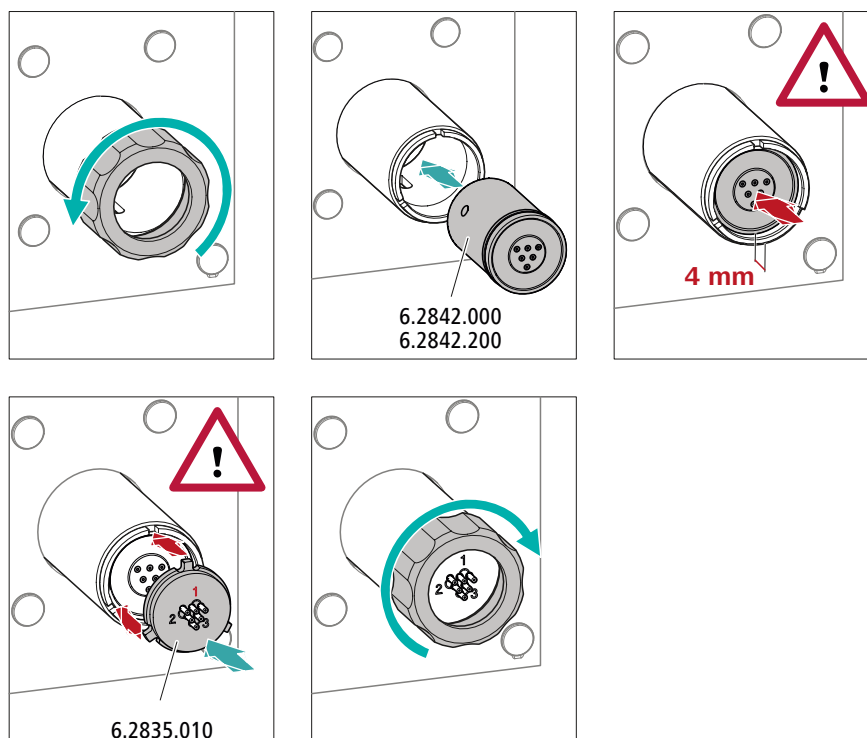

1 Removing the union nut

Loosen the union nut and remove it.

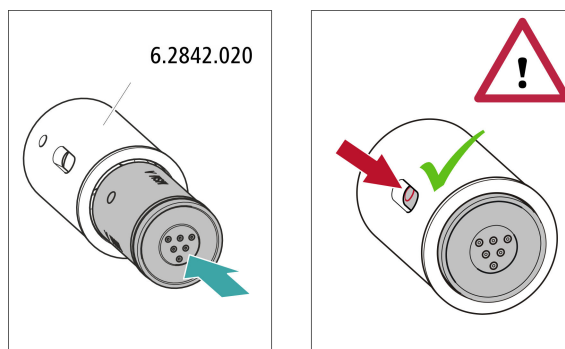

1 Inserting the rotor into the adapter



CAUTION

An incorrectly inserted rotor may be **destroyed** during start-up.

- Clean the sealing surface of the rotor with ethanol using a lint-free cloth.
- Insert the rotor into the adapter so that the tubing connections on the rear of the rotor fit into the corresponding recesses inside the adapter and one of the 3 holes of the rotor is visible in the slot of the adapter.

2 Inserting the adapter

Insert the adapter into the suppressor drive just like a large rotor (see "Inserting large rotors", page 31).

4.10.2 Connecting the Metrohm Suppressor Module (MSM)

The 3 entries and exits of the suppressor units, numbered 1, 2 and 3 on the connecting piece, each have 2 permanently installed PTFE capillaries.

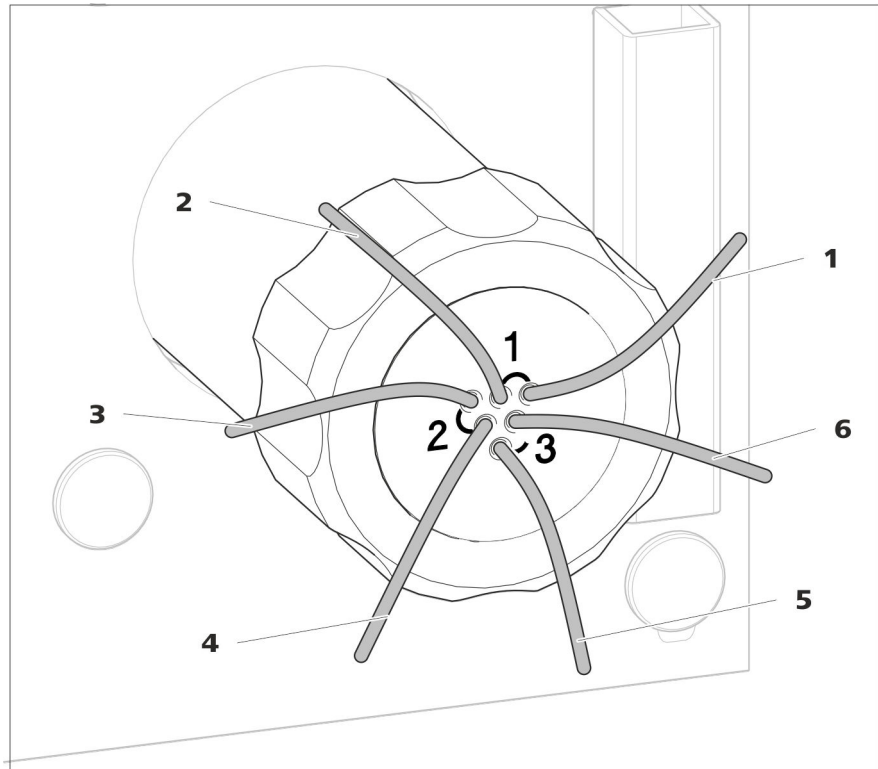
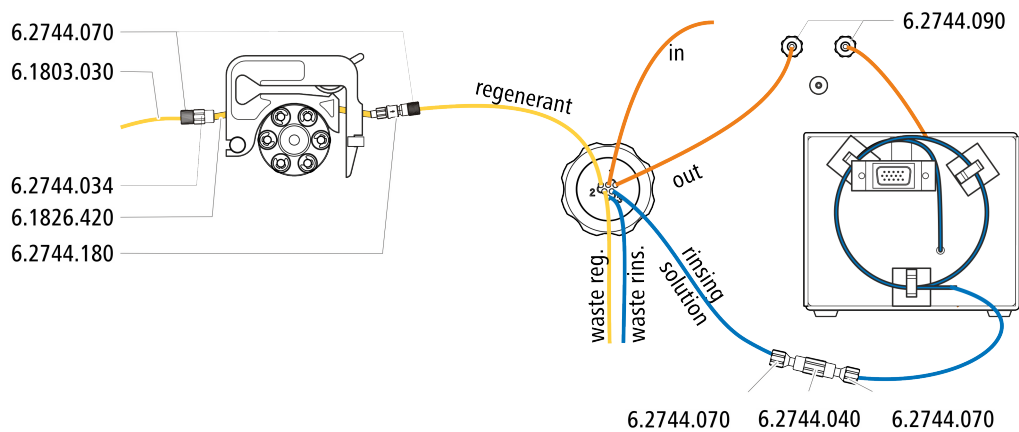

Figure 13 Metrohm Suppressor Module (MSM) – Connection capillaries

1 out Outlet capillary for the eluent.	2 in Inlet capillary for the eluent.
3 regenerant Inlet capillary for the regeneration solution.	4 waste reg. Outlet capillary for the regeneration solution; to the waste container.
5 waste rins. Outlet capillary for the rinsing solution; to the waste container.	6 rinsing solution Inlet capillary for the rinsing solution.

Recommended installation



Alternative installation

For the alternative installation, a second tubing cartridge (6.2755.000) is required that must be ordered separately with the following accessories:

- Tubing cartridge (6.2755.000)
- Coupling olive/UNF 10/32 2x (6.2744.034)
- Pump tubing connection with locking nut and filter (6.2744.180)
- Pump tubing PharMed® (orange/yellow) 3 stoppers (6.1826.420)
- Glass bottle / 1000 mL / GL 45 (6.1608.020)
- Bottle cap / GL 45 - 3 × UNF 10/32 (6.1602.150)
- PTFE capillaries 0.5 mm inner diameter / 3 m (6.1803.030)

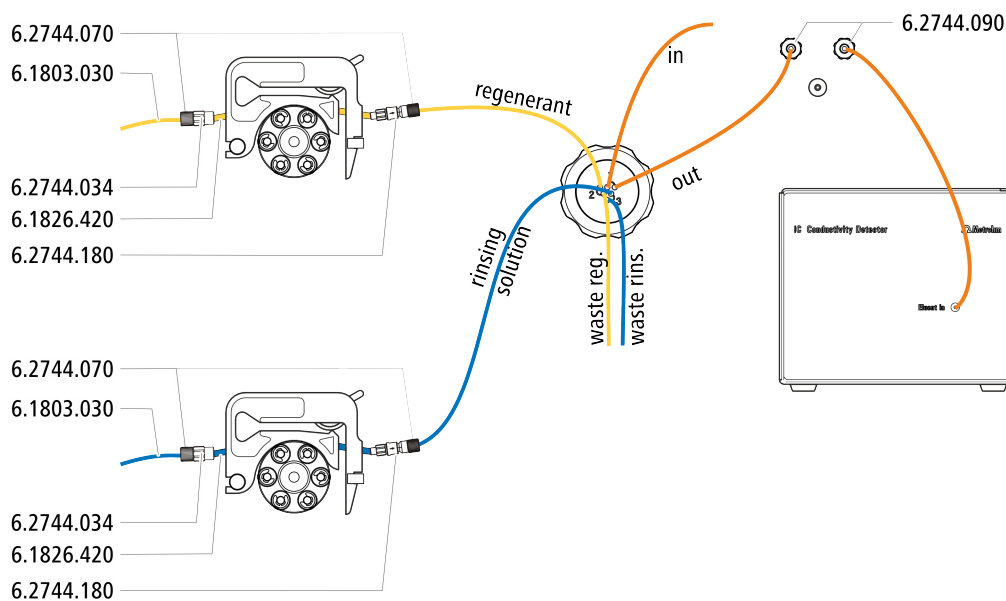

4.10.2.1 Installing the eluent path

The eluent path is connected with the capillaries *in* and *out*.

- 1 Connect the capillary labeled *in* to the exit of the separation column using a short pressure screw (6.2744.070).
- 2 Use a long pressure screw (6.2744.090) to connect the capillary labeled *out* to the inlet of the MCS (see chapter 4.12.2, page 43).

4.10.2.2 Installing bottles with auxiliary solutions

Accessories

To connect the bottles of the auxiliary solutions, you will need the following accessories:

- Accessories from the accessory kit: IC Vario/Flex SeS (6.5000.020)

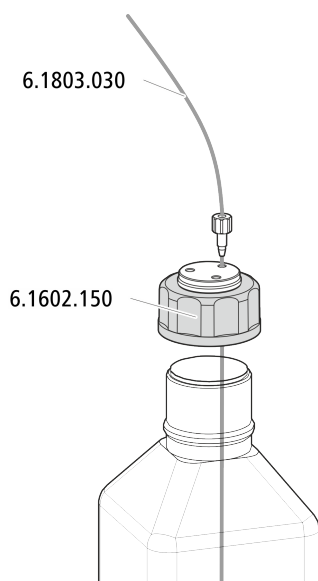

4.10.2.3 Connecting the regeneration solution

The regeneration solution is connected to the *regenerant* capillary.

Connecting the regeneration solution to the peristaltic pump

For this step, you need the following accessories:

- Accessory kit: Flex/Vario: SeS (6.5000.020)
- Pump tubing (6.1826.420)
- Tubing olive with filter and locking nut (6.2744.180)
- Tubing olive (6.2744.034)
- Tubing cartridge of the peristaltic pump

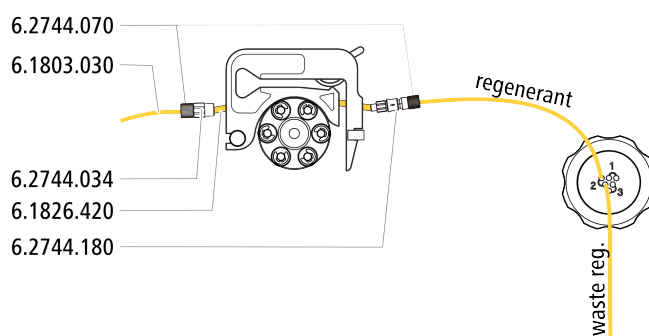

- 1** Prepare a tubing cartridge of the peristaltic pump for the regeneration solution (*see chapter 4.11.1, page 38*).
- 2** Connect the capillary labeled *regenerant* to the exit of the pump tubing using a pressure screw (6.2744.070).
- 3** Connect the PTFE capillary from the regeneration solution bottle to the inlet of the pump tubing.

4.10.2.4 Connecting the rinsing solution

Various possibilities exist for rinsing the Metrohm Suppressor Module:

- Rinsing solution via STREAM (recommended)
Use the eluent from the conductivity detector as rinsing solution.
- Rinsing solution via peristaltic pump
Prepare the rinsing solution in a separate bottle and convey it with the peristaltic pump.

The rinsing solution is connected to the *rinsing solution* capillary.

Connecting the rinsing solution inlet with STREAM

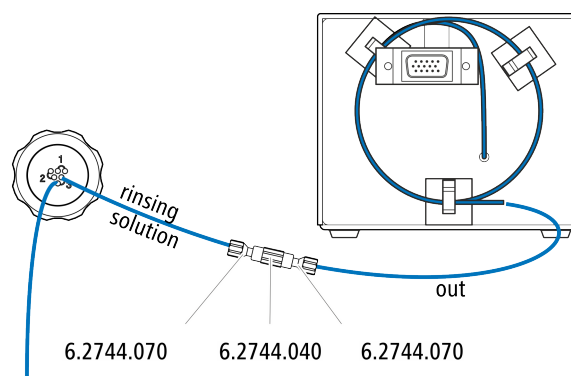

- 1 Connect the detector outlet capillary of the conductivity detector and the capillary labeled *rinsing solution* to each other using a coupling (6.2744.040) and two pressure screws (6.2744.070).



NOTE

The detector outlet capillary must not be shortened.

Connecting the rinsing solution inlet to the peristaltic pump

For this step, you need the following accessories: (not contained in its entirety in the standard accessories):

- Pump tubing (6.1826.420)
- Tubing olive with filter and locking nut (6.2744.180)
- Tubing olive (6.2744.034)
- Tubing cartridge (6.2755.000)
- 2 short pressure screws (6.2744.070)
- PTFE capillary (6.1803.030) (connected with the bottle with the rinsing solution)

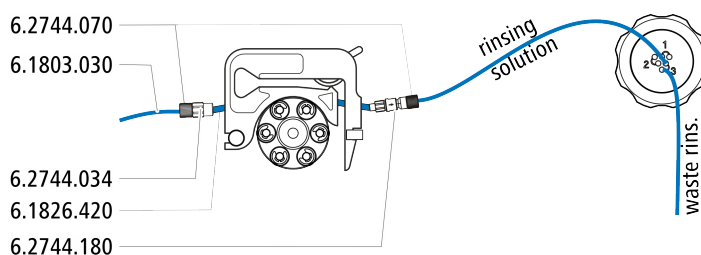

- 1** Prepare a tubing cartridge of the peristaltic pump for the regeneration solution (see chapter 4.11.1, page 38).
- 2** Connect the capillary labeled *rinsing solution* to the exit of the pump tubing using a pressure screw (6.2744.070).
- 3** Connect the PTFE capillary from the rinsing solution bottle to the inlet of the pump tubing.

4.11 Peristaltic pump

4.11.1 Installing the peristaltic pump

Installing the pump tubing

Pump tubing can differ in terms of material, diameter and thus flow rate. Different pump tubing is used depending on the application.

Table 2 Pump tubings



Order number	Name	Material	Inner diameter	Use
6.1826.310	Pump tubing LFL (orange/green), 3 stoppers	PVC (Tygon®)	0.38 mm	Pump tubing for bromate determination using the triiodide method.
6.1826.320	Pump tubing LFL (orange/yellow), 3 stoppers	PVC (Tygon®)	0.48 mm	For acceptor solutions for Inline Dialysis and for Inline Ultrafiltration.
6.1826.330	Pump tubing LFL (orange/white), 3 stoppers	PVC (Tygon®)	0.64 mm	No special applications.
6.1826.340	Pump tubing LFL (black/black), 3 stoppers	PVC (Tygon®)	0.76 mm	For sample solution in Inline Dialysis.
6.1826.360	Pump tubing LFL (white/white), 3 stoppers	PVC (Tygon®)	1.02 mm	For sample transfer.
6.1826.380	Pump tubing LFL (gray/gray), 3 stoppers	PVC (Tygon®)	1.25 mm	For Inline Dilution.

Order number	Name	Material	Inner diameter	Use
6.1826.390	Pump tubing LFL (yellow/yellow), 3 stoppers	PVC (Tygon®)	1.37 mm	For sample solution in Inline Ultrafiltration.
6.1826.420	Pump tubing PharMed® (orange/yellow), 3 stoppers	Ismaprene	0.51 mm	For suppressor solutions.

Selecting the pump tubing and adapter

- 1 Select pump tubing suitable for the application (*see table 2, page 38*).
- 2 Select an adapter suitable for the pump tubing. The adapters are included with the pump tubing connection with locking nut and filter (6.2744.180).

Table 3 Pump tubing and suitable adapters

Pump tubing	Adapter
6.1826.310 (orange/green)	
6.1826.320 (orange/yellow)	
6.1826.330 (orange/white)	
6.1826.340 (black/black)	
6.1826.360 (white/white)	
6.1826.380 (gray/gray)	
6.1826.390 (yellow/yellow)	
6.1826.420 (orange/yellow)	

Installing the pump tubing

For this step, you need the following accessories:

- Tubing cartridge (6.2755.000)
- Pump tubing (6.1826.XXX)
- Coupling olive/UNF 10/32 (6.2744.034)



- Pump tubing connection with locking nut and filter (6.2744.180): Includes a locknut, 3 adapters and a tubing olive with filter holder.
- 2 × pressure screw, short (6.2744.070)

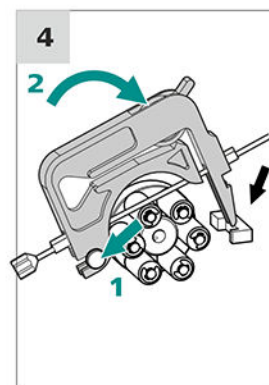
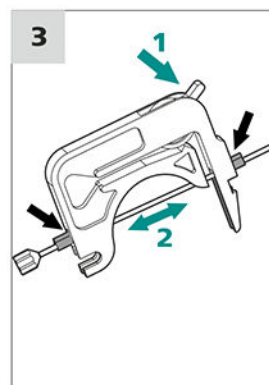
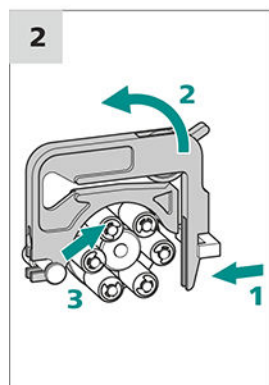
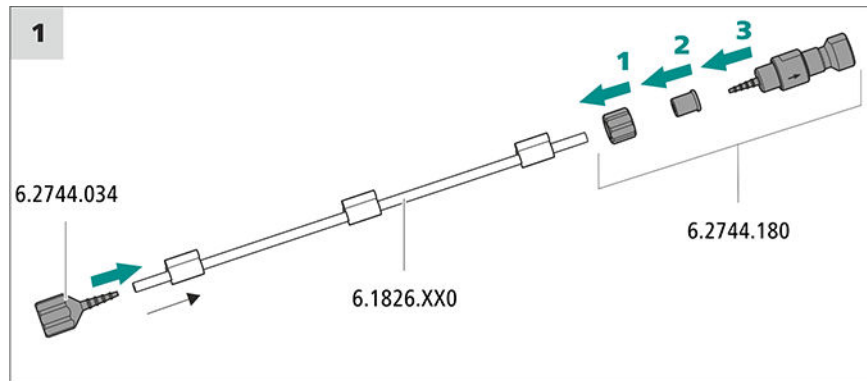

1 Connecting the pump tubing

- Attach the coupling olive/UNF 10/32 (6.2744.034) to the pump tubing inlet. Push the end of the pump tubing over at least the second notch of the olive so that the pump tubing is firmly in place.
- Assemble the pump tubing connection with locking nut and filter (6.2744.180) at the pump tubing exit:
 - Push the locknut onto the pump tubing.
 - Push the appropriate adapter onto the pump tubing.
 - Place the tubing olive with the filter holder into the pump tubing so that the pump tubing is firmly in place; push the end of the pump tubing over at least the second notch of the olive.
 - Tighten it using the union nut.

2 Removing the tubing cartridge

- Press in the tubing cartridge's snap-action lever.
- Tilt the tubing cartridge upwards.
- Unhook the tubing cartridge from the mounting bolt.

3 Inserting the pump tubing

- Press the tubing cartridge's contact pressure lever down all the way.
- Place the pump tubing in the tubing cartridge. Fit the tubing cartridge between two stoppers. The stoppers must snap into the corresponding holder of the tubing cartridge.

4 Inserting the tubing cartridge

- Hang the tubing cartridge in the mounting bolt and press it in the cartridge holder until you hear the snap-action lever snap in.

Setting the flow rate

The flow rate of the peristaltic pump depends on many factors:

- The inner diameter of the pump tubing
- The rotational speed of the drive
- The contact pressure of the tubing cartridge



NOTE

Pieces of pump tubing are consumables. The service life of the pump tubing depends on the contact pressure, among other factors.

Setting the contact pressure correctly

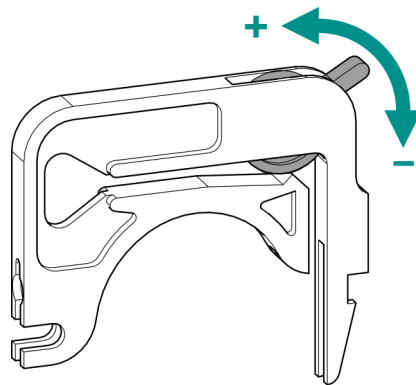

- 1 ▪ Fully loosen the contact pressure lever, i.e. press it all the way down.
 - In the software, activate the drive of the peristaltic pump with the desired speed.
 - Raise the contact pressure lever one step at a time until liquid flows.



- When liquid starts flowing, raise the contact pressure lever by an additional two ratchet increments.

The contact pressure is now set optimally.

4.11.2 Mode of operation for the peristaltic pump

The peristaltic pump is used for pumping sample and auxiliary solutions. It can rotate in both directions.

The peristaltic pump pumps liquids based on the displacement principle. The pump tubing is clamped between the rollers (14-5) and the tubing cartridge (14-2). During operation, the peristaltic pump drive rotates the roller hub (14-6), so that the rollers (14-5) advance the liquid in the pump tubing.

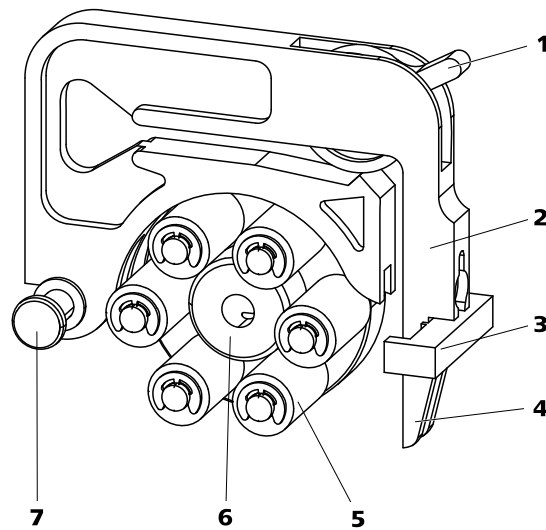

Figure 14 Peristaltic pump

1	Contact pressure lever	2	Tubing cartridge (6.2755.000)
3	Cartridge holder	4	Snap-action lever
5	Rollers	6	Roller hub
7	Mounting bolt		

4.12 Metrohm CO₂ Suppressor (MCS)

4.12.1 General information on the MCS



NOTE

The Metrohm CO₂ Suppressor (MCS) is used only in conjunction with conductivity detection with chemical suppression.

The Metrohm CO₂ Suppressor (MCS) removes the CO₂ from the eluent stream. This lowers the background conductivity, improves detection sensitivity and minimizes the injection peak and carbonate peak.

CO₂ can enter the eluent flow through the sample itself or can develop due to the suppression reaction in the suppressor. Connecting the MCS between the suppressor and detector minimizes the carbonate peak in the chromatogram.

The MCS essentially consists of a degassing cell containing a capillary made from a fluoropolymer membrane. The capillary is permeable to gases. The degassing cell is connected to the vacuum pump. In the degassing cell, the eluent is directed through the capillary made of a fluoropolymer membrane. At the same time, the vacuum pump generates a vacuum and draws in the air from the outside. The pressure and concentration difference this creates in the degassing cell relative to inside the capillary causes the CO₂ to be diffused out of the eluent flow. The ambient air is drawn in by the CO₂ Absorber to filter out the CO₂ from the air.

4.12.2 Connecting the MCS

The MCS is connected between the Metrohm Suppressor Module (MSM) and the conductivity detector.

Connecting the MCS

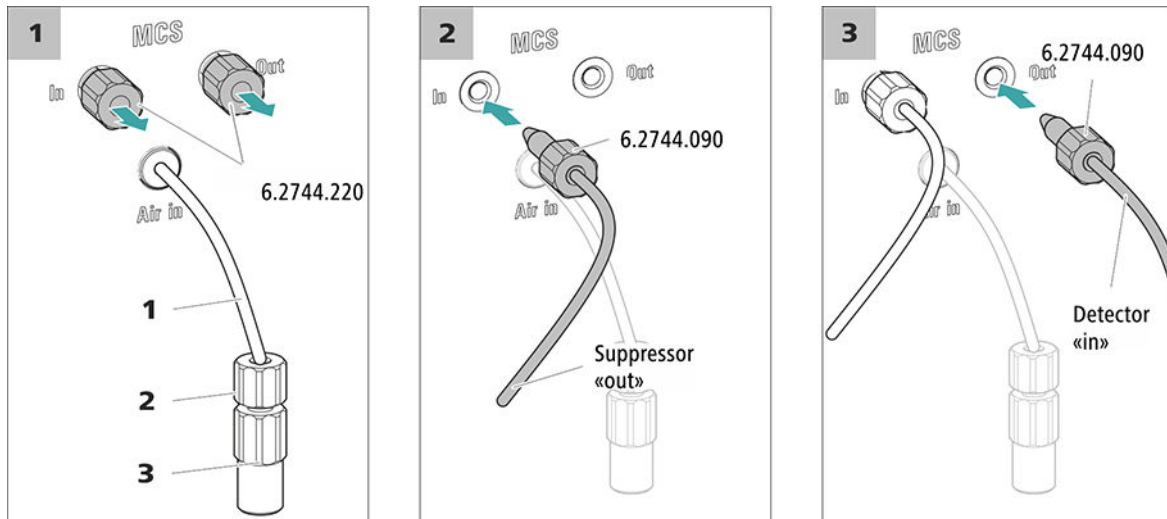

Figure 15 Connecting the MCS

1 Air aspiration capillary

For aspirating air with low CO₂ content (via the CO₂ Absorber).

2 Pressure screw, short (6.2744.070)

Installed on the air aspiration capillary.

3 Luer coupling (6.2744.120)

Mounted on the air aspiration capillary with a pressure screw (6.2744.070).

1 Removing the threaded stoppers

Remove and keep the two threaded stoppers (6.2744.220) from the inlet and outlet of the MCS.

2 Connection from the suppressor

Use a long pressure screw (6.2744.090) to connect the capillary of the MSM labeled **out** to the input of the MCS (labeled **In**).

3 Connection to the detector

Connect the inlet capillary of the conductivity detector with a long pressure screw (6.2744.090) to the MCS outlet (labeled **Out**).



CAUTION

If the MCS is not used, then the inlet and outlet must be sealed with the threaded stoppers (6.2744.220).

4.12.3 Installing the CO₂ Absorber

The aspirated air must have the lowest CO₂ content possible in order for the CO₂ to be removed from the eluent efficiently. In order to achieve this, the air is aspirated through the CO₂ Absorber (6.2837.100).

Accessories

For this step, the following accessories are required:

- CO₂ Absorber (6.2837.100)
The CO₂ Absorber is in the accessory kit: Vario/Flex SeS (6.5000.020).

Preparing the CO₂ Absorber

Prepare the CO₂ Absorber for use as follows:

- 1 Remove the protective cap from the tip of the CO₂ Absorber.

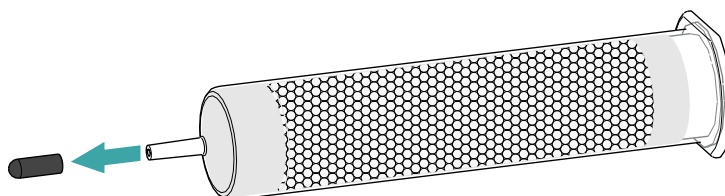

- 2 Attach the dust filter to the tip of the CO₂ Absorber.

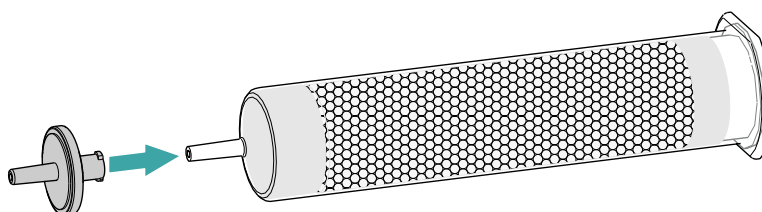

- 3 Remove the label from the lid of the CO₂ Absorber.

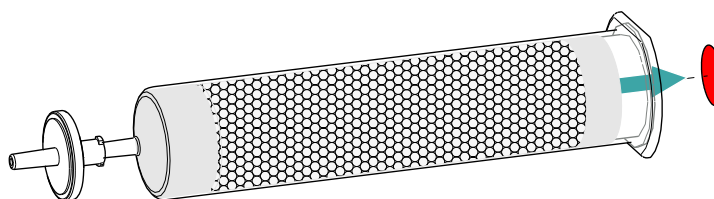

As a result, the small opening in the lid of the CO₂ Absorber is opened, through which the air is then aspirated.

The CO₂ Absorber is now ready for installation.

**NOTE**

The new CO₂ Absorber (6.2837.100) works **without** upstream H₂O adsorber cartridge.

Installing the CO₂ Absorber

Accessories

- Prepared CO₂ Absorber (6.2837.100)

**CAUTION**

The following preparatory steps absolutely must be carried out for CO₂ suppression to operate correctly.

Install the CO₂ Absorber as follows:

1 Connecting the CO₂ Absorber

Attach the capillary connected to the Metrohm CO₂ Suppressor's (MCS) **Air in** connector to the tip of the CO₂ Absorber.

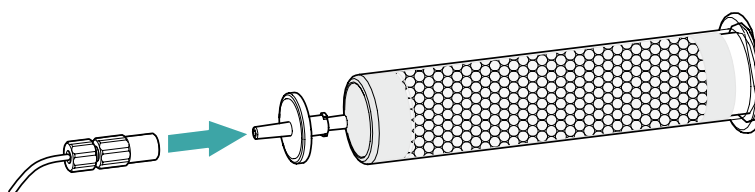
**2 Placing the CO₂ Absorber in the instrument**

- Place the CO₂ Absorber into the instrument's detector chamber.

4.13 Installing the conductivity detector

The 930 Compact IC Flex provides enough space for one detector and additional accessories in the detector chamber. The detector is available as a separate device and is supplied with a separate manual.

Placing the detector in the instrument

Follow the instructions in the chapter *Inserting the detector* in the manual for the detector.

Connecting the detector to the eluent path



NOTE

The separation column is not inserted into the instrument until it is being started up for the first time. Until then, the detector inlet capillary has to be connected to the *out* outlet of the MCS using a long pressure screw (6.2744.090).

Accessories

For this step, you need the following accessories:

- Pressure screw, long (6.2744.090)

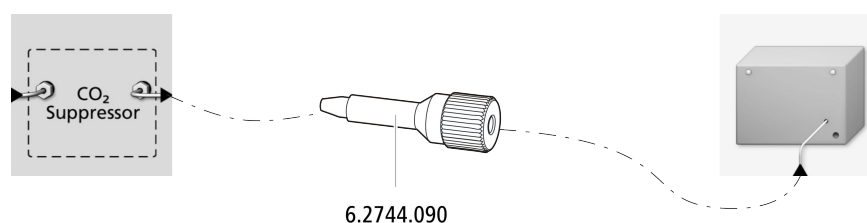

- 1 Tighten the detector inlet capillary to the *Out* outlet of the MCS using a long pressure screw (6.2744.090).

4.14 Installing the amperometric detector

The 930 Compact IC Flex provides enough space for one detector and additional accessories in the detector chamber. The detector is available as separate device and is supplied with a separate manual.

Placing the detector in the instrument

Follow the instructions in the chapter *Inserting the detector* in the manual for the detector.

4.15 Connecting the instrument to a computer



NOTE

If the instrument is connected to the computer, then it must be switched off.

Accessories

For this step, you need the following accessories:

- USB connection cable (6.2151.020) from the accessory kit: Vario/Flex Basic (6.5000.000)

Connecting the USB cable

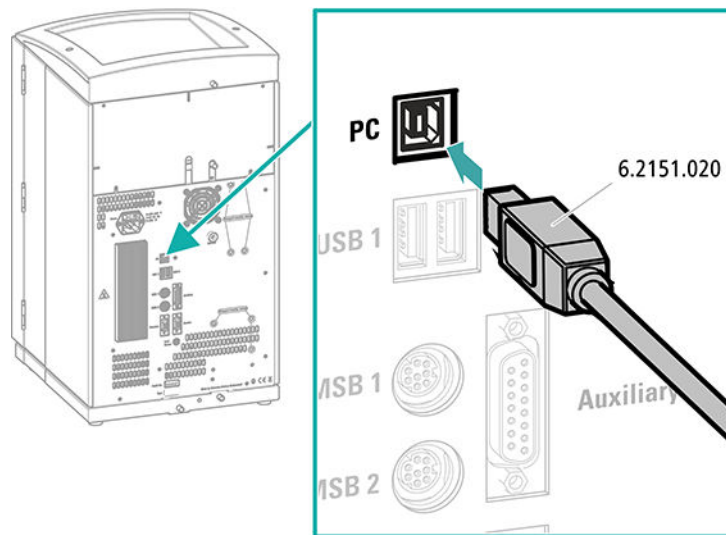

- 1 Insert the USB cable into the computer connection socket on the rear of the instrument.
- 2 Insert the other end into a USB port on the computer.

4.16 Connecting the instrument to the power grid



WARNING

Electric shock from electrical potential

Risk of injury by touching live components or through moisture on live parts.

- Never open the housing of the instrument while the power cord is still connected.
- Protect live parts (e.g. power supply unit, power cord, connection sockets) against moisture.
- Unplug the power plug immediately if you suspect that moisture has gotten inside the instrument.
- Only personnel who have been issued Metrohm qualifications may perform service and repair work on electrical and electronic parts.

Connecting the power cord

Accessories

Power cord with the following specifications:

- Length: max. 2 m
- Number of cores: 3, with protective conductor
- Instrument plug: IEC 60320 type C13
- Conductor cross-section 3x min. 0.75 mm² / 18 AWG
- Power plug:
 - according to customer requirement (6.2122.XX0)
 - min. 10 A



NOTE

Do not use a not permitted power cord!

1 Plugging in the power cord

- Plug the power cord into the instrument's power socket.
- Connect the power cord to the power grid.

3 Starting the equilibration

- Start the equilibration in MagIC Net: **Workplace ▶ Run ▶ Equilibration ▶ Start HW.**

4 Deaerating the high-pressure pump

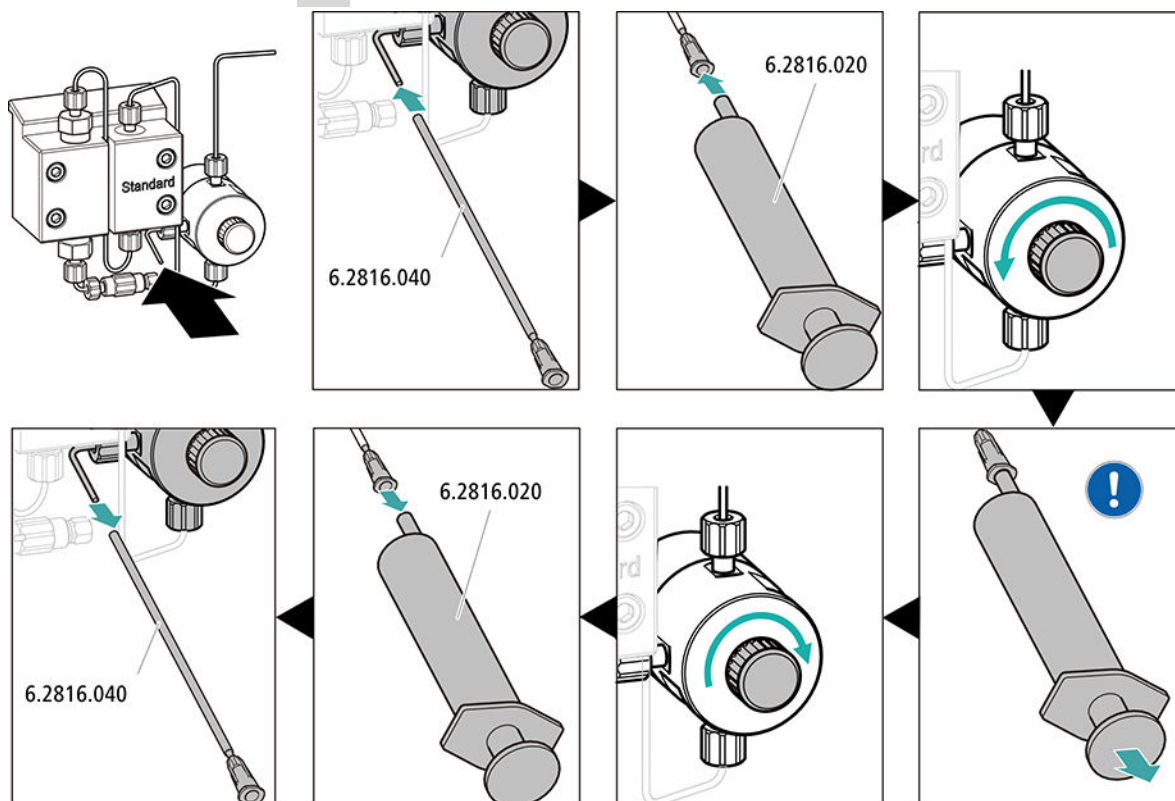

- Push the end of the purge needle (6.2816.040) over the end of the purge capillary on the purge valve.
- Insert the syringe (6.2816.020) in the Luer connector of the purge needle.
- Open the purge valve using the rotary knob (approx. $\frac{1}{2}$ turn).
- Switch on the high-pressure pump in MagIC Net.
- Use the syringe to aspirate eluent until there are no more air bubbles in the eluent aspiration tubing.
- Switch off the high-pressure pump in MagIC Net.
- Seal the purge valve using the rotary knob.
- Remove the syringe from the purge needle.
- Pull the purge needle out of the purge capillary.

5 Adjusting the contact pressure of the peristaltic pump

- Adjust the contact pressure of the peristaltic pump (see "Setting the contact pressure correctly", page 41).

6 Rinsing the instrument without columns

- Rinse the instrument (without columns) with eluent for 10 minutes.

4.18 Connecting and rinsing the guard column

Guard columns protect separation columns and significantly increase their service life. The guard columns available from Metrohm are either actual guard columns or guard column cartridges used together with a cartridge holder. The process of installing a guard column cartridge into the corresponding holder is described in the cartridge leaflet.

**NOTE**

Metrohm recommends always working with guard columns. They protect the separation columns and can be replaced regularly as needed.

**NOTE**

Information regarding which guard column is suitable for your separation column can be found in the **Metrohm Column Program** (which is available from your regional Metrohm representative), the column leaflet and the product information at <http://www.metrohm.com> (Ion Chromatography product area), or it can be obtained directly from your representative.

**CAUTION**

New guard columns are filled with solution and sealed with stoppers or caps on both sides.

Before inserting the guard column, ensure that this solution can be mixed with the eluent being used (follow the information provided by the manufacturer).

**NOTE**

Only connect the guard column after the initial start-up of the instrument (*see chapter 4.17, page 50*). Until then, replace the guard column and the separation column with couplings (6.2744.040).

Accessories

For this step, you need the following accessories:

- Guard column (suitable for separation column)

Connecting the guard column

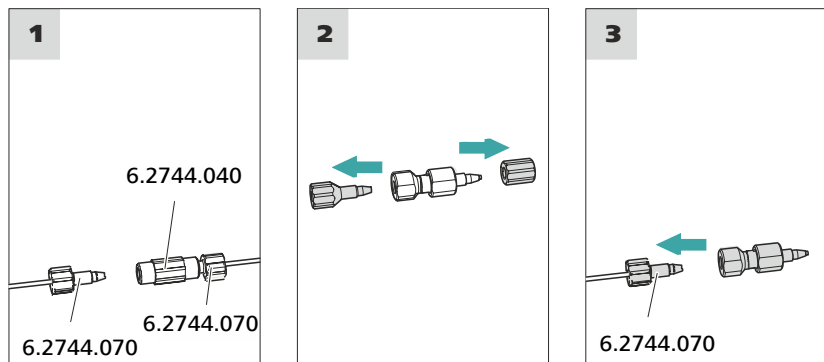

1 Removing the coupling

Remove the coupling (6.2744.040) installed between the column inlet capillary and the column outlet capillary for the initial start-up.

2 Preparing the guard column

- Remove the stoppers or the stopper and the sealing cap from the guard column.

3 Connecting the guard column



CAUTION

When inserting the guard column, ensure that it is inserted correctly based on the marked flow direction (if specified).

- Fasten the inlet of the guard column to the column inlet capillary using a short pressure screw (6.2744.070).
- If the guard column is connected to the separation column using a connection capillary, fasten this connection capillary to the guard column outlet with a pressure screw.

Rinsing the guard column

1 Rinsing the guard column

- Place a beaker under the guard column's outlet.

**NOTE**

Connect the separation column only after the initial start-up of the instrument. Until that point, insert a coupling (6.2744.040) instead of the guard column and separation column.

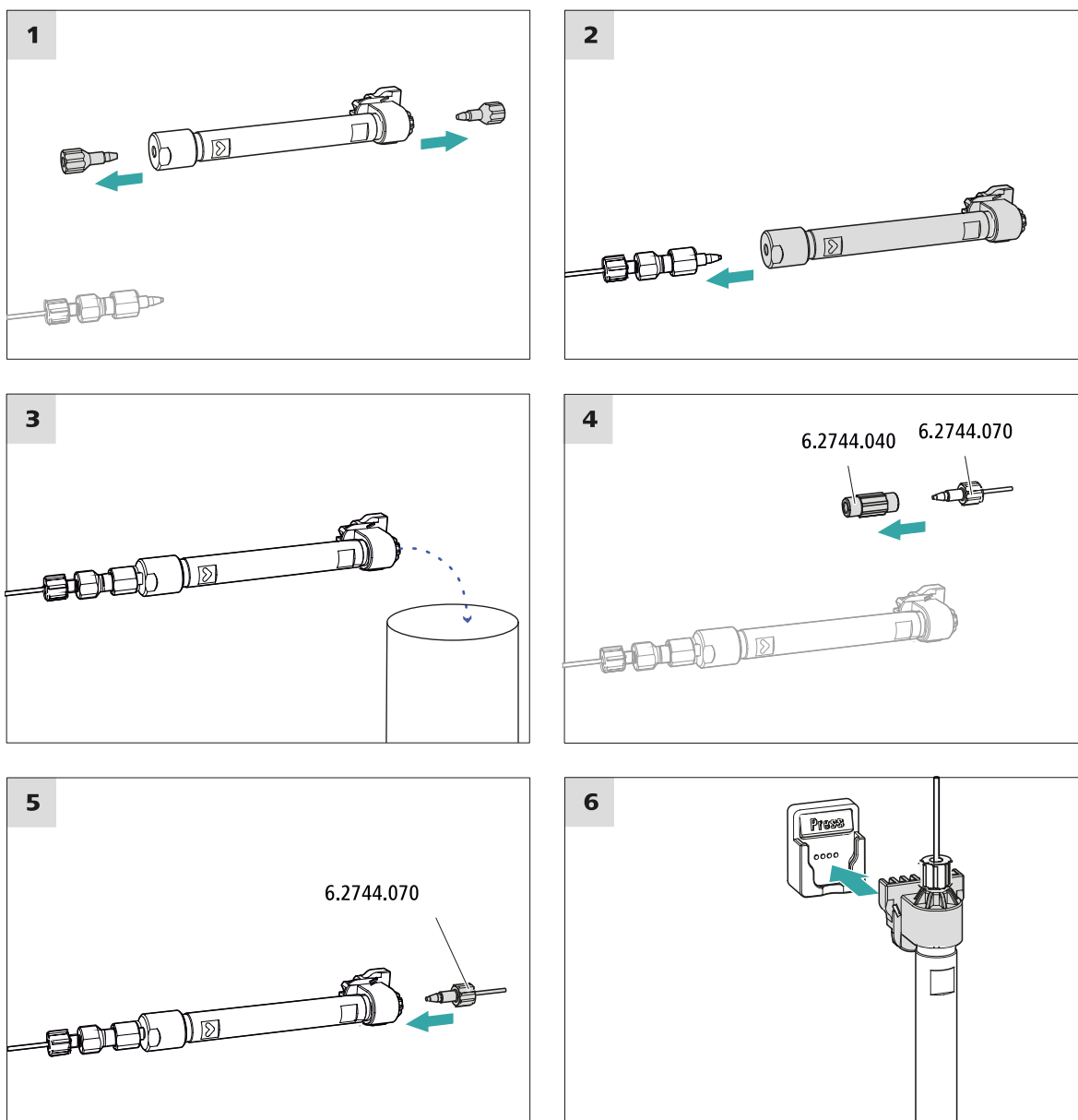
**Connecting the separation column****1 Removing the stoppers**

- Remove the stoppers from the separation column.

4.20 Conditioning

In the following cases, the system must be conditioned with eluent until a stable baseline has been reached:

- After installation
- After each time the instrument is switched on
- After each eluent change



NOTE

The conditioning time can lengthen considerably if the composition of the eluent is modified.

Conditioning the system

1 Preparing the software



CAUTION

Ensure that the configured flow rate is not higher than the flow rate permitted for the corresponding column (refer to the column leaflet and chip data record).

- Start the **MagIC Net** computer program.
- Open the **Equilibration** tab in MagIC Net: **Workplace ► Run ► Equilibration**.
- Select (or create) a suitable method.
Also see: *MagIC Net Tutorial* and online help.

2 Preparing the instrument

- Ensure that the column is inserted correctly in accordance with the flow direction marked on the sticker (arrow has to point in the direction of flow).
- Ensure that the eluent aspiration tubing is immersed in the eluent and that there is enough eluent in the eluent bottle.

3 Starting the equilibration

- Start the equilibration in MagIC Net: **Workplace ► Run ► Equilibration ► Start HW**.



- Visually inspect whether all capillaries and their connections from the high-pressure pump to the detector are leak-tight. If eluent is leaking out anywhere, tighten the corresponding pressure screw further, or loosen the pressure screw, check the end of the capillary and shorten it using the capillary cutter if necessary and retighten the pressure screw.

4 Conditioning the system

Continue rinsing the system with eluent until the desired stability level for the baseline has been attained .

The instrument is now ready for measuring samples.

5 Operation

The 930 Compact IC Flex SeS/PP is operated solely using the MagIC Net software. You can find information on operating the software in the tutorial for MagIC Net or in the online help.

6 Operation and maintenance

6.1 IC system

6.1.1 Operation

In order to avoid disruptive temperature influences, protect the analysis system, including the eluent bottle, from direct sunlight.

6.1.2 Care

The instrument requires appropriate care. Excess contamination of the instrument results in malfunctions and a reduction in the service life of the sturdy mechanical and electronic components.

The instrument must be cleaned immediately if chemicals or solvents are spilled on it. In particular, the plug connections (particularly the power plug) must be protected against contamination.



CAUTION

The instrument has been designed so that liquid is largely prevented from being able to get inside the instrument. However, unplug the power plug immediately if you suspect that corrosive media have gotten inside the instrument. This is the only way to prevent extreme damage to the instrument electronics. Notify Metrohm Service.



WARNING

Electric shock caused by live parts

Never open the housing of the instrument.

Only trained personnel are permitted to open the housing of the instrument.

6.1.3 Maintenance by Metrohm Service

Maintenance of the instrument is best carried out as part of an annual service performed by specialist personnel from Metrohm. A shorter maintenance interval is recommended if you frequently work with caustic and corrosive chemicals. Metrohm Service offers every form of technical advice for maintenance and service of all Metrohm instruments.

6.1.4 Shutting down and recommissioning

If the instrument is no longer used for a prolonged period, remove the guard column and the separation column. Rinse the IC system until it is salt-free with a mixture of methanol and ultrapure water (1:4). This prevents eluent salts from crystallizing and then causing damage.

Rinsing the IC system to be free of salts

- 1** In the software, stop the hardware and wait until the pressure in the high-pressure pump has been released.
- 2** Remove the guard column and the separation column from the eluent path. Connect the connection capillaries directly with each other using a coupling (6.2744.040).
- 3** Rinse the IC system for 15 minutes with methanol/ultrapure water mixture (1:4).
- 4** Optional: Only if the IC system is equipped with a suppressor.
In the software, switch the Metrohm Suppressor Module (MSM) 2 times during the rinsing process at 5-minute intervals in each case (STEP command).
- 5** Optional: Only if the IC system is equipped with a suppressor and a peristaltic pump.
Rinse the pump tubings used for the peristaltic pump with water for 15 minutes at level 1. Finish by releasing the contact pressure at the peristaltic pump. Finish by releasing the contact pressure at the peristaltic pump.

Putting the IC system back into operation

- 1** Check that a coupling (6.2744.040) is installed in place of the guard column and the separation column.
- 2** Rinse the IC system with freshly prepared eluent for 15 minutes.
- 3** Remove the coupling and install the guard column and the separation column (*see Chapter 4.18, page 52 and Chapter 4.19, page 54*).

6.4.1 Manufacturing eluent

Chemicals used for manufacturing eluents must have a purity grade of at least "p.a.". They may be diluted only by using ultrapure water (resistance > 18.2 MΩ*cm). (These specifications apply generally for all reagents used in ion chromatography.)

Newly manufactured eluents always need to be microfiltered (0.45 µm filter).

The composition of the eluent plays a critical role in chromatographic analysis:

Concentration	An increase in the concentration generally leads to shorter retention times and faster separation, but also to a higher background conductivity signal.
pH	pH changes lead to shifts in dissociation equilibria and thus to changes in retention times.
Organic solvents	Adding organic solvents (e.g. methanol, acetone or acetonitrile) to a watery eluent generally speeds up lipophilic ions.

6.4.2 Changing the eluent

Ensure that no precipitates can form when changing the eluent. Immediately successive solutions must be miscible. If the system must be rinsed with organic solvents, several solvents with rising or falling lipophilicity must be used.



NOTE

To change the eluent, remove the guard column and the separation column. Connect the capillaries using a coupling (6.2744.040) and two pressure screws (6.2744.070).

6.5 Notes on operating the high-pressure pump



CAUTION

The pump head is filled ex works with methanol/ultrapure water. Ensure that the eluent used is miscible with this solvent.

Keep the following recommendations in mind in order to protect the high-pressure pump from damage as much as possible during operation:

- To protect the high-pressure pump from **foreign particles**, we recommend filtering the eluent through a filter with a pore size of 0.45 µm and aspirating it via an aspiration filter (6.2821.090).
- Ensure that no precipitates can form when changing the eluent. Salt crystals between the piston and seal cause abrasive particles that can find their way into the eluent. These particles lead to contaminated valves, an increase in pressure and, in extreme cases, scratched pistons and thus to leakages in the high-pressure pump.
Immediately successive solutions must always be miscible. If the system must be rinsed with organic solvents, use several solvents with rising or falling lipophilicity.
- In order to protect the pump seals, ensure that the pump is never operated dry. Therefore ensure that the eluent supply is correctly connected and that there is enough eluent in the eluent bottle each time before turning on the pump.

6.6 Servicing the high-pressure pump



NOTE

You can find a video sequence for this task in the *Multimedia Guide IC Maintenance* or on the Internet at <http://ic-help.metrohm.com/>.

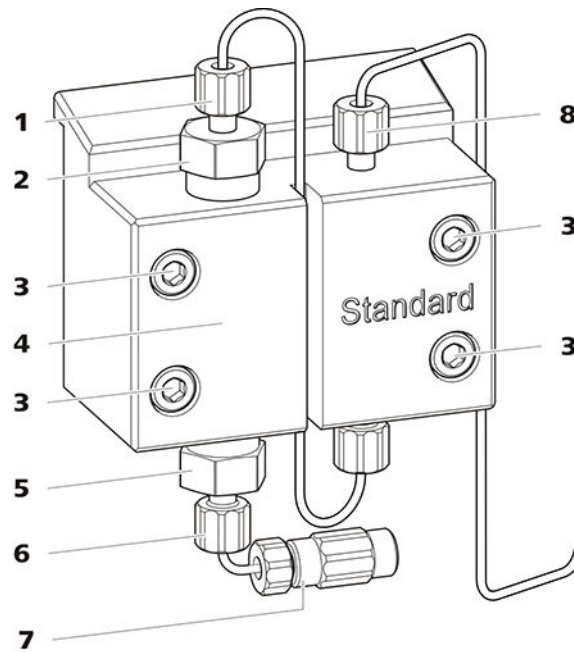

Figure 16 High-pressure pump – Parts

1 Pressure screw, short (6.2744.070) Fastened to the outlet valve holder.	2 Outlet valve holder
3 Fastening screw	4 Pump head
5 Inlet valve holder	6 Pressure screw, short (6.2744.070) Fastened to the inlet valve holder.
7 Eluent aspiration tubing connector Consists of a coupling with a pressure screw.	8 Pressure screw, short (6.2744.070) Fastened to the pump output.

Maintenance interval The following parts of the high-pressure pump must be serviced at least once per year:

- Inlet valve (6.2824.170)
- Outlet valve (6.2824.160)
- Piston seal (6.2741.020)
- Zirconium oxide piston (6.2824.070)

Maintenance tasks can also be carried out if the following problems occur:

- Unstable baseline (pulsations, flow fluctuations)



CAUTION

Maintenance work on the high-pressure pump may not be carried out unless the **instrument is switched off**.



Recommended procedure

We recommend the following procedure for the maintenance of the pump head:

1. Service the inlet valve and the outlet valve.
2. Remove the pump head.
3. Service both pistons, one after the other.
 - a. Remove piston.
 - b. Dismantle the piston.
 - c. Replace the piston seal.
 - d. Replace the zirconium oxide piston.
 - e. Assemble the piston.
 - f. Insert the piston.
4. Reinstall the pump head.

You can find brief video sequences on the following maintenance steps on the Internet at <http://ic-help.metrohm.com/>.

Servicing the outlet valve and inlet valve

Accessories

For this step, you need the following accessories:

You can find these parts in the accessory kit: *Vario/Flex Basic* (6.5000.000).

- Adjustable wrench (6.2621.000)

Cleaning the outlet valve

Spare parts

If the outlet valve cannot be cleaned, you will need a new outlet valve (6.2824.160) for this step.

1 Removing the outlet valve

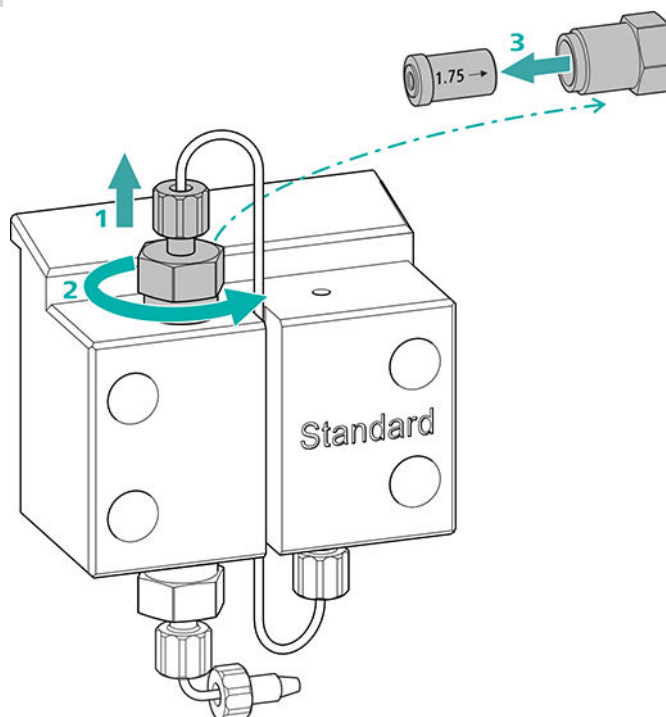

- Unscrew the connection capillary to the auxiliary piston from the outlet valve holder (16-2) (1).
- Start by loosening the outlet valve holder with the adjustable wrench and then unscrew it by hand (2) and remove it.
- Remove the outlet valve from the outlet valve holder (3).

2 Cleaning the outlet valve

- Start by rinsing the outlet valve in the direction of eluent flow using a wash bottle filled with ultrapure water, RBS™ solution or acetone. (The direction of eluent flow is marked on the valve by an arrow.)

The rinsing solution must come out at the valve exit.

If no more solution comes out, then the valve is blocked.

- Rinse the outlet valve in the direction opposite the eluent flow using a wash bottle filled with ultrapure water, RBS™ solution or acetone.

The rinsing solution may only come out at the valve exit.

The outlet valve must be replaced if it is still clogged after cleaning.

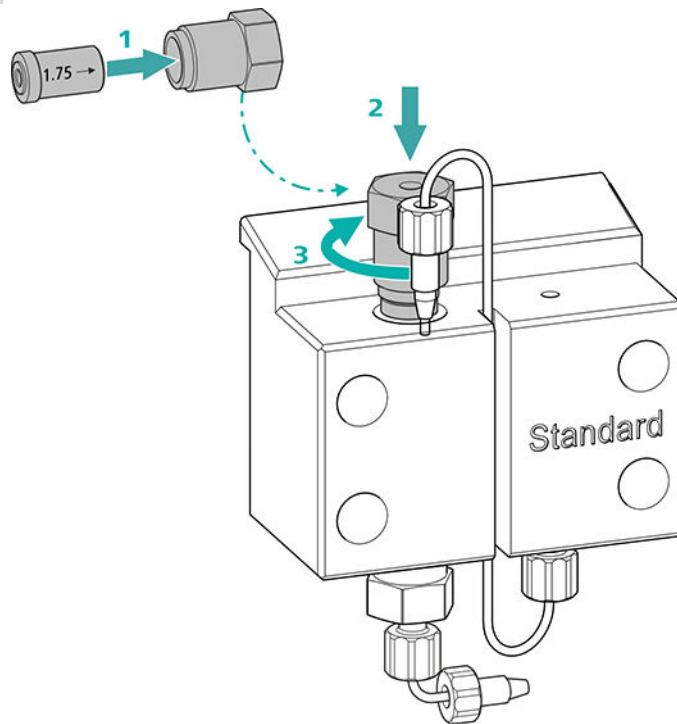
3 Reinserting the outlet valve into the pump head

- Insert the outlet valve into the outlet valve holder (the seal must be visible) (1).
- Screw the outlet valve holder up into the pump head (2) and tighten it firmly by hand and then retighten it one additional $\frac{3}{4}$ turn using the adjustable wrench (3).
- Tighten the connection capillary to the auxiliary piston back onto the outlet valve holder.

Cleaning the inlet valve

Spare parts

If the inlet valve cannot be cleaned, you will need a new inlet valve (6.2824.170) for this step.

1 Removing the inlet valve

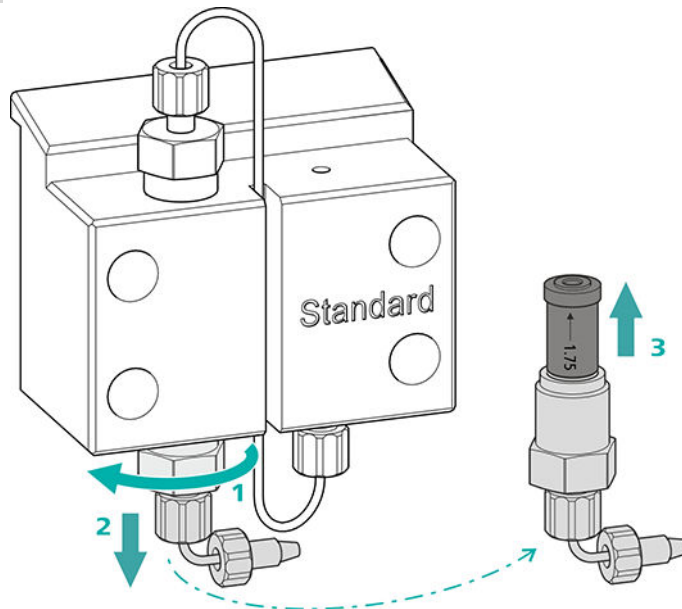

- Unscrew the connection capillary to the connection of the eluent aspiration tubing (16-7).
- Start by loosening the inlet valve holder with the adjustable wrench (1) and then unscrew it by hand (2) and remove it.
- Remove the inlet valve from the inlet valve holder (3).

2 Cleaning the inlet valve

- Start by rinsing the inlet valve in the direction of eluent flow using a wash bottle filled with ultrapure water, RBS™ solution or acetone. (The direction of eluent flow is marked on the valve by an arrow.)

The rinsing solution must come out at the valve exit.

If no more solution comes out, then the valve is blocked.

- Rinse the inlet valve in the direction opposite the eluent flow using a wash bottle filled with ultrapure water, RBS™ solution or acetone.

The rinsing solution may only come out at the valve exit.

The inlet valve must be replaced if it is still clogged after cleaning.

3 Reinserting the inlet valve into the pump head

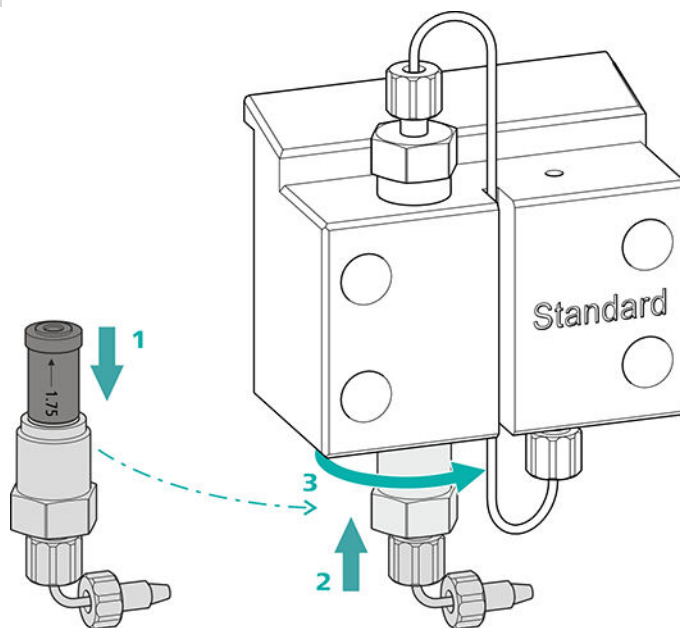

- Insert the inlet valve into the inlet valve holder (the seal must be visible) (1).
- Screw the inlet valve holder up into the pump head (2) and tighten it firmly by hand and then retighten it one additional $\frac{3}{4}$ turn using the adjustable wrench (3).
- Refasten the connection capillary to the connection of the eluent aspiration tubing (16-7).

Removing the pump head

Accessories

For this step, you need the following accessories:

You can find these parts in the accessory kit: *Vario/Flex Basic* (6.5000.000).

- 4 mm hex key (6.2621.030)

Removing the pump head

Prerequisites:

- Is the high-pressure pump switched off?
- Has the pressure been released?
- Is the instrument switched off?

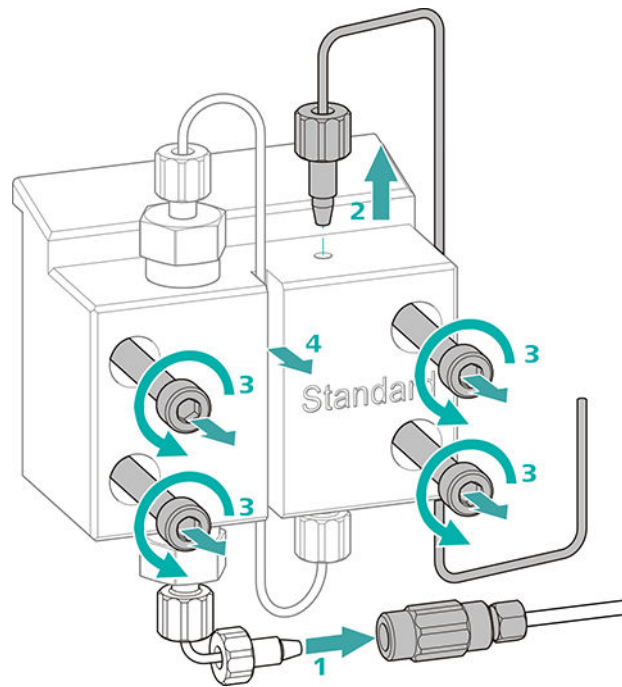

- 1** Release the coupling from the pressure screw and seal it with a stopper.
- 2** Unscrew and remove the pressure screw on the pump head's outlet (16-8).
- 3** Loosen and remove the four fastening screws (16-3) using the hex key.
- 4** Remove the pump head (16-4).

Servicing the piston

Carry out the following work on both pistons in turn.

Servicing a piston consists of the following tasks:

1. Replace the piston seal.
2. Clean or replace the zirconium oxide piston.
3. Reinstall the piston.

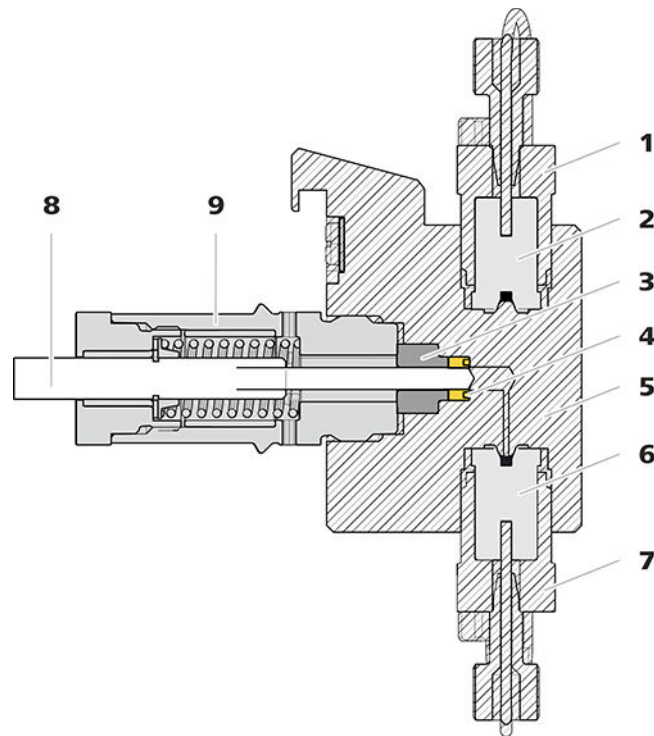

Figure 17 High-pressure pump – Cross-section

1	Outlet valve holder	2	Outlet valve (6.2824.160)
3	Backup ring	4	Piston seal (6.2741.020)
5	Pump head	6	Inlet valve (6.2824.170)
7	Inlet valve holder	8	Zirconium oxide piston (6.2824.070)
9	Piston cartridge		

Accessories

For this step, you need the following accessories:

You can find these parts in the accessory kit: *Vario/Flex Basic* (6.5000.000).

- Adjustable wrench (6.2621.000)
- Tool for piston seals (6.2617.010) consisting of a tip (*18-1*) for removing the old piston seal and a sleeve (*18-2*) for inserting the new piston seal.

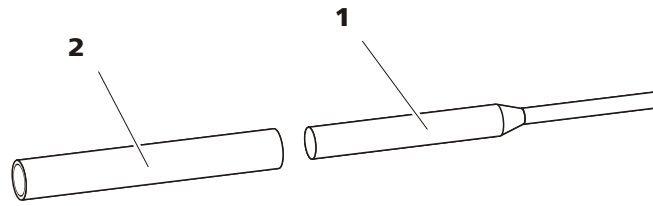

Figure 18 Tool for piston seal (6.2617.010)

1 Tip

2 Sleeve

Spare part

For this step, you need a new piston seal (6.2741.020).

Replacing the piston seal

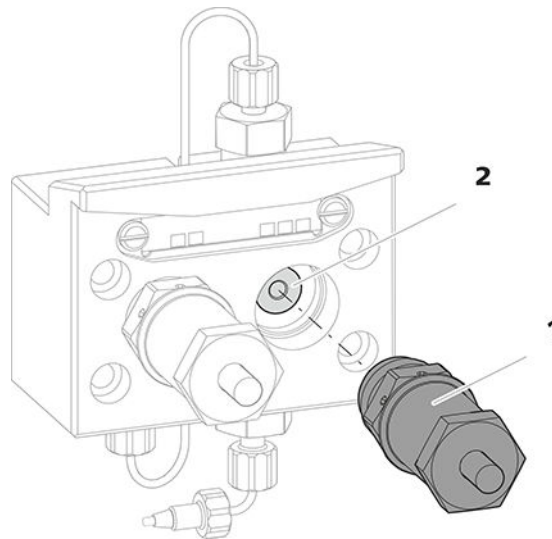

Figure 19 Removing the piston cartridge from the pump head

1 Piston cartridge

2 Backup ring

1 Removing the piston cartridge

Loosen the piston cartridge (19-**1**) using the adjustable wrench and then unscrew it from the pump head by hand. Set it aside.

2 Removing the backup ring

Shake the backup ring (19-**2**) out of the piston opening. Set it aside.



3 Removing the old piston seal



CAUTION

Screwing the (6.2617.010) special tool for the piston seal into the piston seal destroys this completely!



CAUTION

Avoid touching the sealing surface in the pump head with the tool!

Only screw the tip (18-1) of the tool for the piston seal far enough into the piston seal that the seal can be pulled out.

4 Inserting the new piston seal into the tool

Insert the new piston seal into the recess of the sleeve (20-1) of the tool for piston seal. The sealing spring must be visible from the outside.

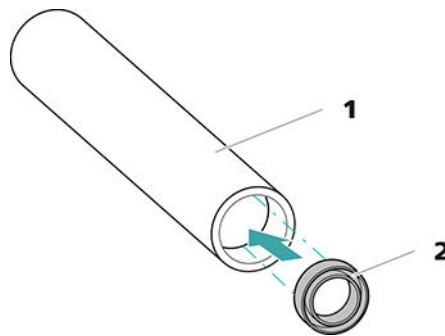

Figure 20 Inserting the piston seal into the tool

1 Tool for piston seal (6.2617.010)
Sleeve for inserting the new piston seal.

2 Piston seal (6.2741.020)

5 Inserting the new piston seal into the pump head

Guide the sleeve (18-2) of the tool for the piston seal with inserted piston seal into the pump head. Press the seal into the pump head recess using the wide end of the tip (18-1) of the tool.

Cleaning or replacing the zirconium oxide piston

Prerequisites:

- The pump head has been removed (see "Removing the pump head", page 70).
- The piston cartridge is removed (see "Replacing the piston seal", page 73).

For this task, you need the following accessories:

- Zirconium oxide piston (6.2824.070)
- Adjustable wrench (6.2621.000) from the accessory kit: *Vario/Flex Basic* (6.5000.000).

1 Breaking down the piston cartridge



CAUTION

Inside the piston cartridge there is a taut spring that can launch out of the piston cartridge if the tension is released suddenly.

When opening the piston cartridge, counteract the pressure from the spring and carefully unscrew the cartridge.

- Loosen the piston cartridge's screw with an adjustable wrench and carefully unscrew the screw by hand while counteracting the pressure from the taut spring.
- Remove the zirconium oxide piston and place it on a paper towel.
- Remove the spring retainer, the spring and the inner plastic sleeve from the piston cartridge and lay them next to the piston.
- Place the backup ring you put aside with the remaining parts.

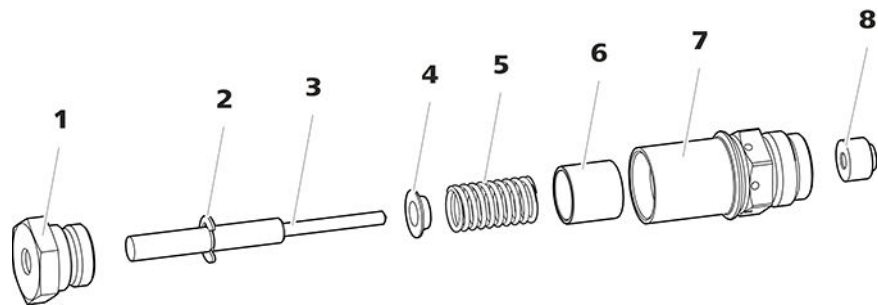

Figure 21 Parts of the piston cartridge

1	Piston cartridge screw	2	Retaining washer
3	Zirconium oxide piston (6.2824.070)	4	Spring retainer
5	Spring (6.2824.060)	6	Inner plastic sleeve Protects from metallic abrasion.
7	Piston cartridge	8	Backup ring



2 Cleaning the parts of the piston cartridge

- If the zirconium oxide piston has become contaminated due to abrasion or deposits, then clean it using a fine abrasive cleaning powder, rinse it using ultrapure water until it is free of particles and dry it.

The zirconium oxide piston must be replaced if it is heavily contaminated or scratched.

- Rinse the other parts of the piston with ultrapure water and dry with a lint-free cloth.

3 Replacing the zirconium oxide piston

- Remove the retaining washer (21-2) from the old piston. If the retaining washer sits too tightly, use a pointed object to loosen the retaining washer.
- Assemble the retaining washer at the same point on the new piston.

4 Putting the piston cartridge together

- Insert the inner plastic sleeve, the spring and the spring retainer into the piston cartridge.
- Slide the zirconium oxide piston carefully into the piston cartridge until its tip emerges from the small opening of the piston cartridge.
- Attach the screw and tighten it by hand.

Mounting the piston

1 Reinserting the backup ring

Clean the backup ring (17-3) with ultrapure water and reinsert it.

2 Reinserting the piston cartridge

Screw the assembled piston cartridge back into the pump head and tighten, first by hand, then also using an adjustable wrench by approx. 15°.

Clean the second piston cartridge in the same way.

Mounting the pump head

For this step, you need the following accessories:

You can find these parts in the accessory kit: *Vario/Flex Basic* (6.5000.000).

Accessories

- 4 mm hex key (6.2621.030)

Mounting the pump head



NOTE

The pump head cannot be mounted the wrong way, as it has fastening bolts with different bore hole depths, i.e., one fastening bolt is longer than all others. The bore hole with the greatest depth must therefore be aligned with the longest bolt.

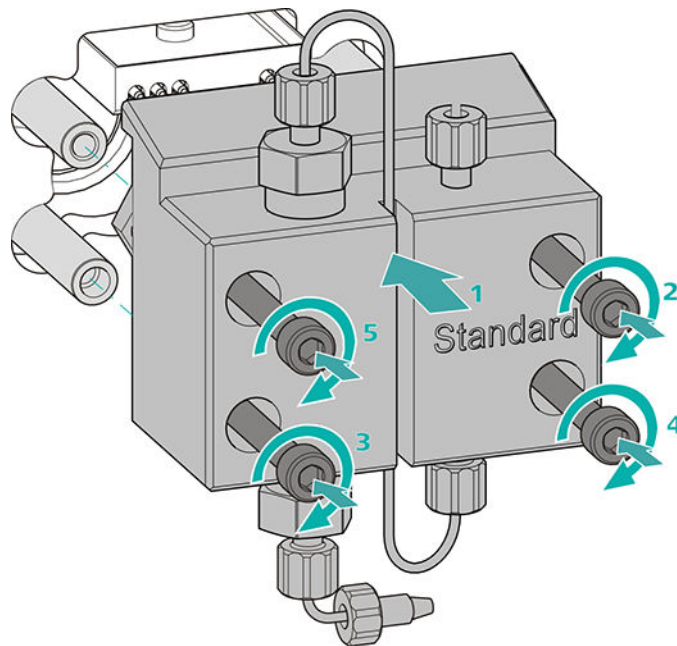

- 1
 - Push the pump head onto the four fastening bolts (1).
 - Tighten the four fastening screws using the hex key (6.2621.030) alternating crosswise.

Connecting the entry and exit for the high-pressure pump

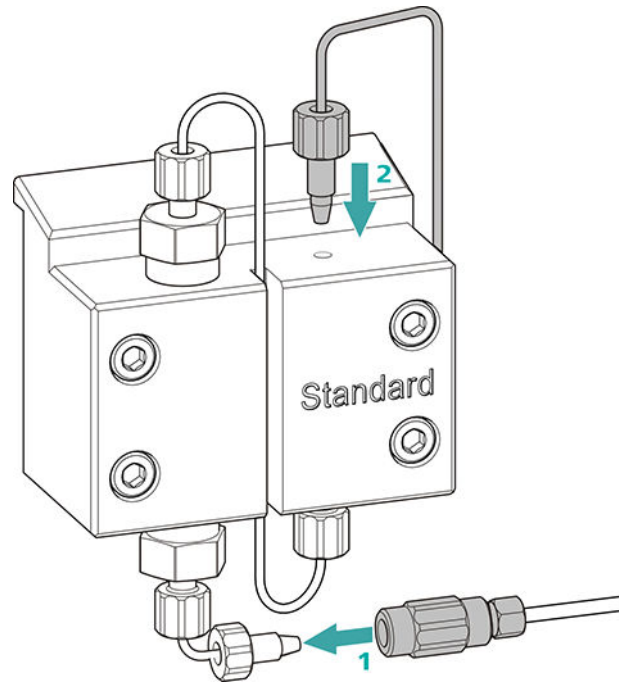

- 1
 - Remove the stopper from the coupling. Tighten the coupling to the pressure screw located on the pump head inlet capillary (1).
 - Reconnect the pump head outlet capillary to the pump head outlet (2).

6.7 Servicing the inline filter



NOTE

You can find a video sequence for this task in the *Multimedia Guide IC Maintenance* or on the Internet at <http://ic-help.metrohm.com/>.

Maintenance interval

The filter must be replaced at least every 3 months; it may need to be replaced more frequently, depending on the application.

Accessories

For this task, you need the following accessories:

- Two adjustable wrenches (6.2621.000) from the accessory kit: Vario/Flex Basic (6.5000.000)
- Tweezers
- A new filter from the packaging (6.2821.130)

Removing the filter

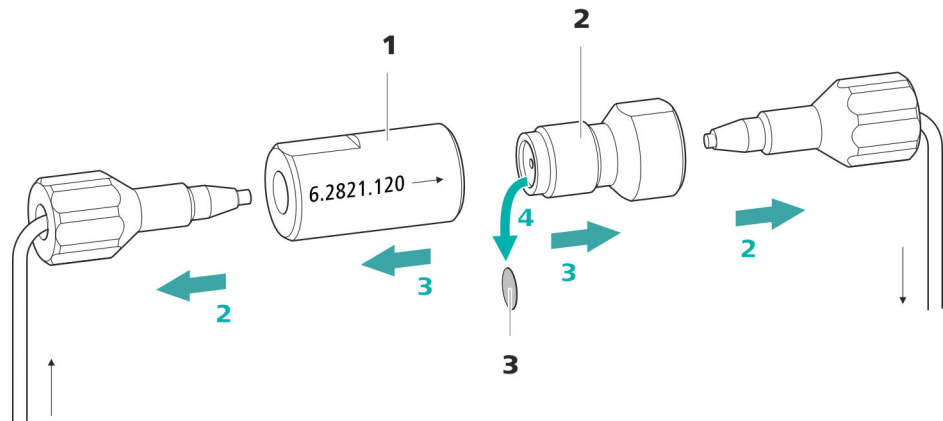

Figure 22 Inline filter – Removing the filter

1 Filter housing

Inline filter housing. Part of the accessories (6.2821.120).

2 Filter screw

Screw for the inline filter. Part of the accessories (6.2821.120).

3 Filter (6.2821.130)

Pack contains 10 pieces.

1 Shutting off the flow

Switch off the high-pressure pump in the software.

2 Removing the inline filter

Unscrew both pressure screws from the inline filter.

3 Unscrewing the filter screw

Use two adjustable wrenches (6.2621.000) to loosen the filter screw (22-2) from the filter housing (22-1) and unscrew it by hand.

4 Removing the filter

Remove the old filter (22-3) using tweezers.

Inserting a new filter

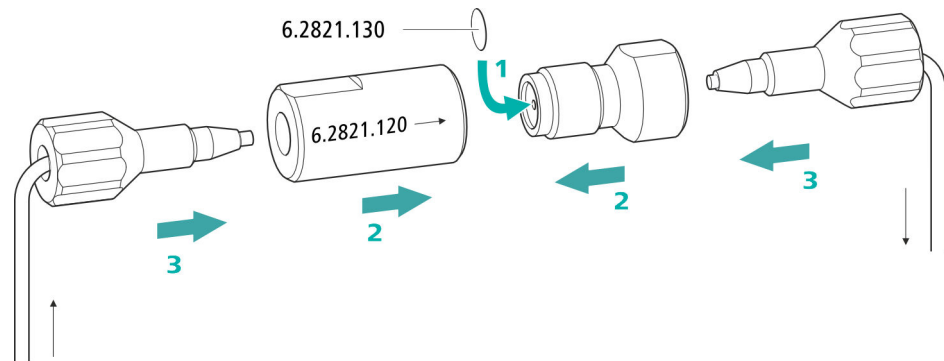

1 Inserting a new filter

- Use tweezers to carefully place a new filter into the filter screw (22-2) so that it is flat and press it firmly into place with the rear of the tweezers.

2 Installing the filter screw

- Screw the filter screw (22-2) back into the filter housing (22-1) and tighten by hand. Then use two adjustable wrenches (6.2621.000) to tighten it slightly.

3 Remounting the inline filter

- Screw pressure screws back onto the inline filter. Take care to ensure that the flow direction matches that inscribed on the inline filter.

4 Rinsing the inline filter

- Dismantle the guard column (if present) and the separation column and replace with a coupling (6.2744.040).
- Rinse the instrument with eluent.
- Reinsert the columns after 10 minutes.

6.8 Servicing the pulsation absorber



CAUTION

The pulsation absorber is maintenance-free and must not be opened.

6.9 Injection valve

Maintenance on the injection valve is best performed by specialist personnel from Metrohm during annual service.

6.10 Metrohm Suppressor Module (MSM)

6.10.1 Notes for operating the Metrohm Suppressor Module (MSM)



NOTE

The suppressor units must never be regenerated in the same flow direction the eluent is pumped. Therefore, always mount the inlet and outlet capillaries according to the diagram outlined in *Chapter Connecting the Metrohm Suppressor Module (MSM)*, page 33.

The Metrohm Suppressor Module (MSM) consists of three suppressor units, which, in rotation, are (1) used for suppression, (2) regenerated with regeneration solution and (3) rinsed with ultrapure water or with suppressed eluent. In order to record each new chromatogram under comparable conditions, work is normally performed with a freshly regenerated and rinsed suppressor unit.



CAUTION

The Metrohm Suppressor Module (MSM) must never be switched over if liquid is not flowing through it, since otherwise it may become jammed. If the Metrohm Suppressor Module (MSM) is in a dry state, it must be rinsed for at least five minutes before it may be switched over.



CAUTION

The Metrohm Suppressor Module (MSM) must be regenerated (see chapter 6.10.3.2, page 83), cleaned (see chapter 6.10.3.4, page 85) or replaced (see chapter 6.10.3.5, page 88) if the capacity of the Metrohm Suppressor Module (MSM) is reduced or if the backpressure is high.

6.10.2 Taking care of the suppressor housing



CAUTION

The transparent suppressor housing can become fogged.

The suppressor housing is made of PMMA (poly(methyl methacrylate)). It can become scratched and foggy if cleaned improperly. This can make viewing the rotor difficult or impossible.

- Do **not use any scouring agents** for cleaning.
- Do **not use any solvents** for cleaning.

6.10.3 Servicing the Metrohm Suppressor Module (MSM)

6.10.3.1 Parts of the Metrohm Suppressor Module (MSM)

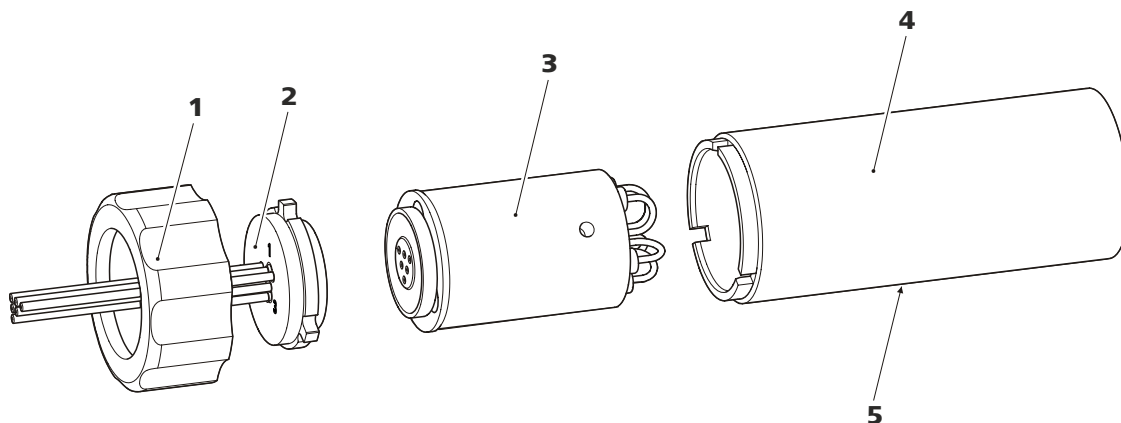

Figure 23 Parts of the Metrohm Suppressor Module (MSM)

1	Union nut	2	Connecting piece
3	Rotor	4	Housing
5	Slot in the housing		

6.10.3.2 Regenerating the anion suppression rotor

If the anion suppressor units are loaded with certain heavy metals (such as iron) or organic contamination for long periods, then the standard regeneration solution may no longer be able to completely remove them. This constantly reduces the capacity of the suppressor units, which results in reduced phosphate sensitivity in mild cases and a large increase in the baseline in severe cases.

If such capacity problems occur at one or more positions, all anion suppressor units must be regenerated with one of the following solutions:

Regeneration solutions

- **Contamination with heavy metals or elevated backpressure:**
1 mol/L H₂SO₄ + 0.1 mol/L oxalic acid
- **Contamination with organic cationic complexing agents:**
0.1 mol/L H₂SO₄ / 0.1 mol/L oxalic acid / acetone 5%
- **Heavy contamination with organic substances:**
0.2 mol/L H₂SO₄ / acetone ≥ 20%
- **Contamination by certain environmental samples**
1 mol/L H₃PO₄



NOTE

If phosphoric acid has been used once as regeneration solution in an IC system, you will have to continue using phosphoric acid for regeneration. Regenerating it with sulfuric acid again can lead to problems in the baseline.



CAUTION

Pump tubing made of PVC must not be used for solutions containing organic solvents.

We recommend using the high-pressure pump for regeneration.

Regenerating the anion suppressor rotor

1 Disconnecting the Metrohm Suppressor Module (MSM) from the IC system

- Disconnect the capillaries of the MSM labeled **regenerant** and **rinsing solution** from the IC system.



2 Regenerating the Metrohm Suppressor Module (MSM)

Regenerate the three suppressor units one after the other for approx. 15 minutes using one of the solutions mentioned above.

- Connect the capillary labeled **regenerant** to the outlet of the high-pressure pump using a coupling (6.2744.040).
- Set the flow of the high-pressure pump to 0.5 mL/min in the software.
- Connect the regeneration solution to the high-pressure pump.
- Switch on the high-pressure pump.
If the pressure decreases during regeneration, slowly increase the flow of the pump to a maximum of 2 mL/min. When doing so, make sure that the pressure does not exceed 2 MPa!
- After approx. 15 minutes, switch off the high-pressure pump.
- In the software, use the **Step** command to switch to the next suppressor unit and regenerate it as described above.
- As soon as all three suppressor units have been regenerated, disconnect the capillary labeled **regenerant** from the coupling.

3 Rinsing the Metrohm Suppressor Module (MSM)

After regeneration, each of the three suppressor units must be rinsed with degassed ultrapure water for about 15 minutes.

- Connect the capillary labeled **rinsing solution** to the outlet of the high-pressure pump using a coupling (6.2744.040).
- Set the flow of the high-pressure pump to 0.5 mL/min in the software.
- Connect the ultrapure water to the high-pressure pump.
- Switch on the high-pressure pump.
If the pressure decreases during rinsing, slowly increase the flow of the pump to a maximum of 2 mL/min. When doing so, make sure that the pressure does not exceed 2 MPa!
- After approx. 15 minutes, switch off the high-pressure pump.
- In the software, use the **Step** command to switch to the next suppressor unit and rinse it as described above.
- As soon as all three suppressor units have been rinsed, disconnect the capillary labeled **rinsing solution** from the coupling.

4 Connecting the Metrohm Suppressor Module (MSM) to the IC system

- Reconnect the capillaries of the MSM labeled **regenerant** and **rinsing solution** to the IC system.
- Reconnect the entry and the exit of the high-pressure pump to the IC system.

6.10.3.3 Regenerating the cation suppression rotor

If the cation suppressor units are exposed to certain contaminations for prolonged periods, then these contaminations can no longer be removed completely with the standard regeneration solution. The performance of the suppressor units declines continuously, as indicated by a rise of the baseline or asymmetrical peaks.

If such problems occur at one or more positions, then treat all of the cation suppressor units as follows:

Regenerating the cation suppressor

1 Stopping the regeneration solution

Stop the regeneration solution feed.

2 Regenerating the first cation suppressor unit

Rinse the system with eluent until the suppressor unit is completely exhausted (indicated by a significant increase in conductivity). This can take up to 240 minutes under standard conditions.

3 Regenerating the second cation suppressor unit

In the software, use the **Step** command to switch to the next suppressor unit. Repeat step 2.

4 Regenerating the third cation suppressor unit

In the software, use the **Step** command to switch to the next suppressor unit. Repeat step 2.

5 Restoring the regeneration solution

As soon as all three suppressor units are completely exhausted, restore the regeneration solution feed.

6 Equilibrating the system

Equilibrate the system as usual (*see chapter "Conditioning" in the manual for the ion chromatograph*).

6.10.3.4 Cleaning the Metrohm Suppressor Module (MSM)

In the following cases, it may be necessary to clean the Metrohm Suppressor Module (MSM):

- Increased backpressure at the MSM's connection tubing.

For an overview of the rotors, see figure , page 30

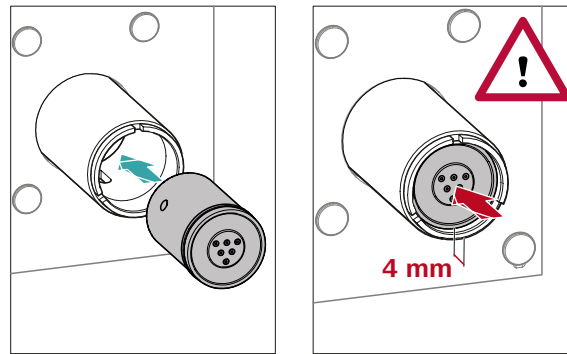

- Insert the rotor (23-3) into the housing (23-4) in such a way that the tubing connections on the rear of the rotor fit into the corresponding recesses inside the housing and one of the three holes of the rotor is visible from below in the slot of the housing (23-5).



NOTE

The rotor's sealing surface is located approx. 4 mm deep inside the suppressor drive if the rotor is inserted correctly.

If this is not the case, then the rotor must be moved into the correct position using careful turning. If the rotor cannot be turned or removed, it can be moved into the correct position from below by means of a pointed object (e.g. a screwdriver).

6 Cleaning the connecting piece

- Clean the sealing surface of the connecting piece (23-2) with ethanol using a lint-free cloth.

7 Inserting the connecting piece

See also Chapter 4.10.1, page 31

- Insert the connecting piece (23-2) into the housing in such a way that connector 1 is on top and the three pins of the connecting piece fit into the corresponding recesses on the housing.
- Reattach the union nut (23-1) and tighten by hand (do not use a tool).

8 Connecting and conditioning the Metrohm Suppressor Module (MSM)

- Reconnect the MSM to the IC system.

- Before switching the MSM over for the first time, rinse each of the three suppressor units with solution for five minutes.

6.10.3.5 Replacing parts of the Metrohm Suppressor Module (MSM)

Parts of the Metrohm Suppressor Module (MSM) may need to be replaced in the following cases:

- Irremediable loss of suppressor capacity (reduced phosphate sensitivity and/or significant rise in the baseline).
- Irremediable blockage of the MSM (solutions can no longer be pumped through the MSM).

Both the rotor and the connecting piece can be replaced.

Replacing parts of the Metrohm Suppressor Module (MSM)

1 Disconnecting the Metrohm Suppressor Module (MSM) from the IC system

- Switch off the instrument.
- Disconnect all capillaries of the MSM from the IC system.

2 Dismantling the Metrohm Suppressor Module (MSM)

- Unscrew the union nut (23-1) from the housing (23-4).
- Pull the connecting piece (23-2) out of the housing together with the rotor (23-3).

If the rotor gets stuck in the housing, you can push it out as follows:

Put a pointed object into the slot in the housing and use it to push out the rotor.

- Loosen the connecting piece from the rotor with a turning movement.

3 Cleaning the new rotor

- Clean the sealing surface of the new rotor (23-3) with ethanol using a lint-free cloth.

4 Inserting the new rotor



CAUTION

The rotor may be destroyed during start-up if it is not inserted correctly.

**NOTE**

The adapter (6.2842.020) (see "Inserting small rotors", page 32) is required in order to insert a small rotor into the suppressor drive.

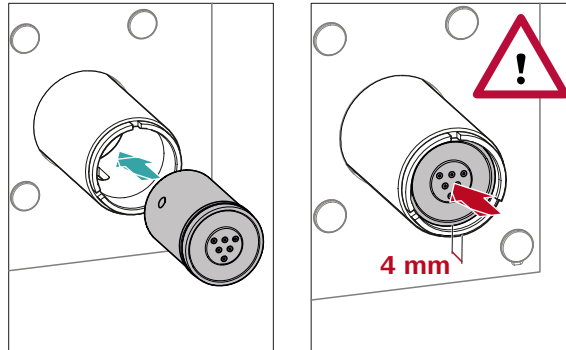

- Insert the new rotor (23-3) into the housing (23-4) in such a way that the tubing connections on the rear of the rotor fit into the corresponding recesses inside the housing and one of the three holes of the rotor is visible from below in the slot of the housing (23-5).

**NOTE**

The rotor's sealing surface is located approx. 4 mm deep inside the suppressor drive if the rotor is inserted correctly.

If this is not the case, then the rotor must be moved into the correct position using careful turning. If the rotor cannot be turned or removed, it can be moved into the correct position from below by means of a pointed object (e.g. a screwdriver).

5 Cleaning the new connecting piece

- Clean the sealing surface of the new connecting piece (23-2) with ethanol using a lint-free cloth.

6 Inserting the new connecting piece

See also Chapter 4.10.1, Page 31

- Insert the connecting piece (23-2) into the housing in such a way that connector 1 is on top and the three pins of the connecting piece fit into the corresponding recesses on the housing.
- Reattach the union nut (23-1) and tighten by hand (do not use a tool).

7 Connecting and conditioning the Metrohm Suppressor Module (MSM)

- Reconnect all capillaries of the MSM to the IC system.
- Before switching the MSM over for the first time, rinse the three suppressor units with solution for five minutes.

6.11 Peristaltic pump

6.11.1 Notes on operating the peristaltic pump

The flow rate of the peristaltic pump depends on the drive speed (set using the software), the contact pressure and, above all, the inner diameter of the pump tubing. Depending on the application, different pump tubing is used. Select pump tubing that best matches your application (see table 2, page 38).



CAUTION

The service life of the pump tubing primarily depends on the contact pressure.

If the peristaltic pump is switched off for long periods, lift up the tubing cartridges on the right side by releasing the snap-action levers. This ensures that the contact pressure will be maintained once it has been set.



CAUTION

The pump tubing (6.1826.xxx) is made of PVC or PP and therefore must not be used for rinsing with solutions containing organic solvents. In this case, use different pump tubing or use another pump for rinsing.

6.11.2 Servicing the peristaltic pump

6.11.2.1 Replacing the pump tubing

Pieces of pump tubing inserted into the peristaltic pump are consumables with a limited service life.

Pieces of pump tubing with 3 stoppers are tensioned in the tubing cartridge so that they end up positioned between two stoppers. This results in two possible positions for the tubing cartridge. Once the pump tubing exhibits significant signs of wear, it can be tensioned a second time in the other respective position.

Maintenance interval Replace the pump tubing every 2 months.

Replace the pump tubing every 4 weeks if the peristaltic pump is being used continuously.

6.11.2.2 Replacing the filter

The filters inserted into the pump tubing connection with locking nut and filter (6.2744.180) must be replaced regularly.

Maintenance interval We recommend replacing the filters (6.2821.130) (24-2) every 3 months. The filters may need to be replaced more frequently, depending on the application.

Accessories For this step, you need the following accessories:

- 1 filter from the spare filter set (6.2821.130)
- 2 adjustable wrenches (6.2621.000)
- Tweezers

Replacing the filter

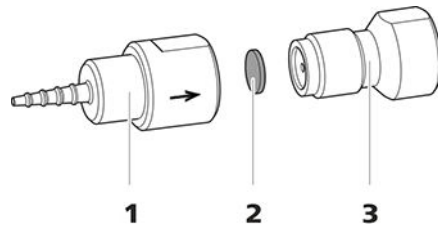

Figure 24 Pump tubing connection – Replacing the filter

1 Tubing olive

2 Filter (6.2821.130)
Pack contains 10 pieces.

3 Filter screw

1 Unscrewing the filter screw

- Unscrew the filter screw (24-3) from the tubing olive (24-1) using the two adjustable wrenches.

2 Replacing the filter

- Remove the old filter (24-2) using tweezers.
- Use tweezers to place the new filter (24-2) on the filter screw (24-3) so that it is **flat** and press it firmly into place with the rear of the tweezers.

6.13 Detector maintenance

Follow the maintenance instructions in the the detector's manual.

6.14 Rinsing the sample path

Before a new sample is measured, the sample path must be rinsed with it long enough to prevent the measuring result from being falsified by the previous sample (sample carry-over).

The time required to rinse the sample path with the new sample is called the rinsing time. The rinsing time depends on the transfer time.

The transfer time corresponds to the time the sample needs to flow from the sample vessel to the end of the sample loop. The transfer time depends on the following factors:

- The pump capacity of the peristaltic pump or of the Dosino that is used for the sample transfer.
- The total capillary volume
- The volume of the gas removed from the sample by the sample degasser (if a sample degasser is present and connected)

The transfer time can be determined as follows:

Determining the transfer time

1 Emptying the sample path

Pump air through the sample path (pump tubing, tubing connections, capillary in the degasser, sample loop) for several minutes until all liquid is displaced by the air.

2 Unscrewing the sample loop

Unscrew the end of the sample loop.

3 Aspirating the sample and measuring the time

Aspirate a sample typical for the later application and use a stop-watch to measure the time the sample needs to go from the sample vessel to the end of the sample loop.

The time upon stopping the watch is the "transfer time".

4 Tightening the sample loop again

Tighten the sample loop again.



If the sample is injected automatically, the rinsing time must be at least three times the **transfer time**.

Checking the rinsing time

You can determine if the applied rinsing time is sufficient by measuring the sample carry-over directly. Proceed as follows to do this:

1 Preparing two samples

- **Sample A:** A typical sample for the application.
- **Sample B:** Ultrapure water.

2 Determining "Sample A"

Allow "Sample A" to run through the sample path for the duration of the rinsing time; inject and then measure it.

3 Determining "Sample B"

Allow "Sample B" to run through the sample path for the duration of the rinsing time; inject and then measure it.

4 Calculating the sample carry-over

The sample carry-over corresponds to the ratio of the peak areas of the measurement from Sample B to the measurement from Sample A. The smaller this ratio, the smaller the amount of sample carry-over. This ratio can be changed by varying the rinsing time. This can be used to determine the required rinsing time for the application.

6.15 Separation column

6.15.1 Separating efficiency

The analysis quality that can be attained depends in a large part on the separating efficiency of the separation column being used. The separating efficiency of the selected separation column must be sufficient for the current analysis problems. If difficulties arise, start by checking the quality of the separation column in each case by recording a standard chromatogram.

You can find detailed information on the separation columns available from Metrohm in the leaflet provided along with your separation column, in the **Metrohm IC Column Program** (available from your Metrohm representative) or on the Internet at <http://www.metrohm.com> in the Ion Chromatography product area. You can find information on special IC applications in the corresponding "**Application Bulletins**" or "**Application Notes**", which are available on the Internet at <http://>

.....

www.metrohm.com in the Applications area or free of charge upon request from your responsible Metrohm representative.

6.15.2 Protecting the separation column

We recommend using the following protective measures so that the separation column retains its separating efficiency for as long as possible:

- Microfilter both the sample and the eluent (0.45 µm filter) and aspirate the eluent via the aspiration filter (6.2821.090) as well.
- Always use a guard column. Information regarding which guard column is suitable for your separation column can be found in the **Metrohm IC Column Program** (which is available from your Metrohm representative), the leaflet provided along with your separation column or the product information about the separation column at <http://www.metrohm.com> (Ion Chromatography product area), or it can be obtained directly from your representative.
- Use the pulsation absorber.

6.15.3 Storing the separation column

Always store separation columns you do not need in a sealed and filled state according to the column manufacturer's specifications.

6.15.4 Regenerating the separation column

The separation column can be regenerated according to the column manufacturer's specifications if the separation characteristics of the column have deteriorated. You can find information on regenerating separation columns available from Metrohm on the leaflet provided with every column.



NOTE

Regeneration is intended as a last resort. It should not be carried out regularly.

Problem	Cause	Remedy
	<i>The MSM is blocked.</i>	<ul style="list-style-type: none"> Regenerate the MSM (see chapter 6.10.3.2, page 83). <p>Note: 6.2821.180 pump tubing connection with filter must be used.</p>
	<i>Guard column – Blocked.</i>	Replace the guard column (see chapter 4.18, page 52).
	<i>Separation column – Blocked.</i>	<ul style="list-style-type: none"> Regenerate the separation column (see chapter 6.15.4, page 95). Replace the separation column (see "Connecting the separation column", page 55). <p>Note: Samples should always be microfiltered .</p>
	<i>Injection valve – blocked.</i>	Have the valve cleaned (by a Metrohm service engineer).
The retention times in the chromatogram have changed unexpectedly.	<i>Eluent - Incorrect concentration</i>	Create eluent with correct concentration.
	<i>Separation column – Diminished separating efficiency.</i>	<ul style="list-style-type: none"> Regenerate the separation column (see chapter 6.15.4, page 95). Replace the separation column (see "Connecting the separation column", page 55).
	<i>The eluent contains gas bubbles.</i>	<ul style="list-style-type: none"> Purge the high-pressure pump (see figure , page 51).
	<i>High-pressure pump – Defective.</i>	Request Metrohm Service.
Peak areas are lower than expected.	<i>Sample – There is a leak in the sample path.</i>	Find and fix the leak in the sample path.
	<i>Sample – The sample path is blocked.</i>	Find and eliminate the blockage in the sample path.
	<i>Sample – The sample loop is not (completely) filled.</i>	Adjust the transfer time for the sample (see "Determining the transfer time", page 93).
	<i>Sample – There are gas bubbles in the sample.</i>	Use the sample degasser .
	<i>MCS – The CO₂ suppressor is not connected.</i>	Connect the CO ₂ suppressor.

Problem	Cause	Remedy
	<i>The eluent contains gas bubbles.</i>	<ul style="list-style-type: none"> ▪ Purge the high-pressure pump (see chapter 4.17, page 50).
Baseline increasing strongly.	<i>Insufficient flow of regeneration solution or rinsing solution.</i>	See problem "MSM – Insufficient flow of regeneration solution or rinsing solution."
	<i>MSM – Reduced capacity.</i>	Regenerate the MSM (see chapter 6.10.3.2, page 83).
	<i>SPM – Reduced capacity.</i>	Regenerate the SPM (see chapter 6.10.3.2, page 83).
Chromatograms have poor resolution	<i>Separation column – Diminished separating efficiency.</i>	<ul style="list-style-type: none"> ▪ Regenerate the separation column (see chapter 6.15.4, page 95). ▪ Replace the separation column (see "Connecting the separation column", page 55).
Extreme spread of the peaks in the chromatogram. Splitting (dual peaks)	<i>Capillary connections – Dead volume in the system.</i>	Check the capillary connections (see chapter 4.2, page 15) (use PEEK capillaries with an inner diameter of 0.25 mm between the injection valve and the detector).
	<i>Guard column – Diminished efficiency.</i>	Replace the guard column (see chapter 4.18, page 52).
	<i>Separation column – Dead volume at the column head.</i>	<ul style="list-style-type: none"> ▪ Install the separation column in the opposite flow direction (if the leaflet says this is permissible) and rinse into a beaker. ▪ Replace the separation column (see "Connecting the separation column", page 55).
Precision problems - the measured values are highly scattered.	<i>Injection valve – Sample loop.</i>	Check the installation of the sample loop (see "Optional: Exchanging the sample loop", page 29).
	<i>Sample – There are gas bubbles in the sample.</i>	Use the sample degasser .
	<i>Sample – The rinsing volume is too small.</i>	Increase the rinsing time (see chapter 6.14, page 93).
	<i>Injection valve – Defective.</i>	Request Metrohm Service.



Problem	Cause	Remedy
	<i>MCS – The vacuum is too low.</i>	<ul style="list-style-type: none">▪ Check the connectors. If they are OK:▪ Contact the regional Metrohm service representative.

8 Technical specifications

8.1 Reference conditions

The technical specifications listed in this chapter refer to the following reference conditions:

<i>Ambient temperature</i>	+25 °C (±3 °C)
<i>Instrument status</i>	> 40 minutes in operation

8.2 Ambient conditions

Operation

<i>Nominal function range</i>	+5 to +45 °C at max. 80% relative humidity, non-condensing
-------------------------------	---

<i>Storage</i>	+5 to +45 °C at max. 80% relative humidity, non-condensing
----------------	---

<i>Altitude / Pressure range</i>	max. 3,000 m.a.s.l. sea level / min. 700 mbar
----------------------------------	---

<i>Overvoltage category</i>	II
-----------------------------	----

<i>Pollution degree</i>	2
-------------------------	---

8.3 Housing

Dimensions

<i>Width</i>	302 mm
--------------	--------

<i>Height</i>	562 mm
---------------	--------

<i>Depth</i>	368 mm
--------------	--------

<i>Base tray, housing and bottle holder material</i>	Polyurethane hard foam (PUR) with flame retardation for fire class UL 94 V-0, CFC-free, coated
--	--

<i>IP degree of protection</i>	IP 20
--------------------------------	-------

Controls

<i>Indicators</i>	LED for standby indicator
-------------------	---------------------------

<i>On/off switch</i>	On the rear of the instrument
----------------------	-------------------------------



8.4 Weight

2.930.1500 24.68 kg (without accessories)

8.5 Leak sensor

Type Electronic, no calibration necessary

8.6 High-pressure pump

Type

- Serial dual-piston pump
- Intelligent pump head recognition
- Chemically inert
- Metal-free pump heads
- Materials in contact with the eluent: PEEK, ZrO₂, PTFE/PE
- Self-optimizing flow and pressure

Flow rate

Adjustable flow range 0.001–20 mL/min
0.01–5 mL/min with standard PEEK pump head

Flow increment 1 µL/min

Reproducibility of the eluent flow < 0.1% deviation

Pressure range

Pump 0–50.0 MPa (0–500 bar)

Pump head 0–35.0 MPa (0–350 bar) (applies for the standard PEEK pump head)

Residual pulsation < 1%

Safety shutdown

Function Automatic shutdown upon reaching the pressure limits

Maximum pressure limit

- Adjustable from 0.1–50 MPa (1–500 bar)
- The pump is automatically shut down at the first piston stroke above the maximum limit value

Minimum pressure limit

- Adjustable from 0–49 MPa (0–490 bar)
- The shutdown mechanism is inactive at 0 MPa
- The shutdown mechanism becomes active two minutes after system start
- The pump is automatically shut down after three piston strokes below the minimum pressure limit

8.7 Injection valve

<i>Actuator switching time</i>	typ. 100 ms
<i>Maximum operating pressure</i>	35 MPa (350 bar)
<i>Material</i>	PEEK

8.8 Metrohm Suppressor Module (MSM)

<i>Resistance to solvents</i>	No restriction
<i>Switching time</i>	typ. 100 ms

8.9 Peristaltic pump

<i>Type</i>	2-channel peristaltic pump
<i>Rotation direction</i>	Clockwise/counterclockwise
<i>Rotational speed</i>	0–42 rpm in 7 levels of 6 rpm each
<i>Pumping characteristics</i>	0.3 mL/min at 18 rpm; with standard pump tubing (6.1826.420)
<i>Pump tubing material</i>	Recommended: PharMed® (Ismaprene)

8.10 Metrohm CO₂ Suppressor (MCS)

<i>Material</i>	Fluoropolymer
<i>Resistance to solvents</i>	no restriction (except PFC)
<i>Vacuum</i>	
<i>Working range</i>	microprocessor-controlled/stabilized
<i>Time to establish after starting</i>	< 30 s
<i>Capillary volume</i>	400 µL
<i>Recommended flow range</i>	0.1–1.0 mL/min

Index

A

Ambient conditions 101
 Anion suppressor
 Regeneration 83
 Aspiration filter (6.2821.090) 62
 Aspiration tubing for eluent 22

B

Baseline
 Condition 58
 Unstable 65

C

Capillaries
 Installation 15
 Carry-over 93
 Cation suppressor
 Regeneration 85
 Clean
 Inlet valve 69
 Outlet valve 67
 Suppressor 85
 CO₂ Absorber
 Connector 45
 Replace 92
 Column
 see "Separation column" 54
 Column recognition 104
 Computer connection 48
 Conditioning 58
 Connect
 Power grid 49
 To computer 48
 Connections
 Installation 15
 Contamination
 High-pressure pump 64
 Valves for the high-pressure
 pump 65
 Contamination of suppressor
 Heavy metals 83
 Organic 83
 Crystallization
 High-pressure pump 64

D

Detector
 Interface 104
 Dimensions 101
 Door 62

Drainage tubing
 Installation 19

E

Electrostatic charge 7
 Eluent
 Aspirate 22
 Change 63
 Manufacturing 63
 Eluent bottle
 Installation 21
 Energy supply 104
 Equilibration 51, 57

F

Feed-through
 For cables 12
 For capillaries 12
 Filter
 Aspiration filter 62
 see "Inline filter" 27
 Flow fluctuations 65
 Flow increment 102
 Flow range 102
 Flow rate 102
 Frequency 104

G

Guard column
 Installation 52
 Rinse 52, 53

H

Heavy metals
 Contamination of suppressor
 83
 High-pressure pump
 Maintenance 64
 Protection 19, 64
 Technical specifications 102
 Housing 101
 Humidity 101

I

IC column
 see "Separation column" 54
 Injection valve 2
 Installation 28
 Maintenance 81
 Technical specifications 103

Inline filter 27
 Installation
 Connections 15
 Drainage tubing 19
 Eluent bottle 21
 Guard column 52
 Injection valve 28
 Leak sensor 21
 MCS 43
 Peristaltic pump 38
 Pulsation absorber 27
 Pump tubing 38
 Separation column 54
 Suppressor 30

Interface

 Further connections 104
 Leak sensor 104
 MSB 104
 USB 104
 Interfaces 104

L

Leak sensor
 Installation 21
 Interface 104
 Technical specifications 102
 Leak-tightness 52
 Leakage 65
 Leaky piston seals 65
 Loop
 See also "Sample loop" 28

M

Maintenance
 High-pressure pump 64
 Injection valve 81
 Peristaltic pump 90
 Suppressor 81
 Material 101
 MCS
 Absorber connector 45
 Capillary connection 43
 Installation 43
 Technical specifications 103
 Use 43
 MSB 104

O

Operation 101
 Peristaltic pump 90

Index

- Suppressor 81
- Organic contamination
- Suppressor 83
- Overvoltage category 101
- P**
-
- Peristaltic pump
- Installation 38
 - Maintenance 90
 - Mode of operation 42
 - Operation 90
 - Technical specifications 103
- Piston of the high-pressure pump 65
- Piston seal 65
- Power connection 49
- Power consumption 104
- Power supply unit 104
- Precipitate 64
- Pressure increase 64
- Pressure limit 102
- Pressure range 102
- Protection
- Inline filter 27
- Pulsation 65
- Pulsation absorber
- Installation 27
- Pump tubing
- Install 38
 - Service life 90
- Pump tubings
- Overview 38
- R**
-
- Reference conditions 101
- Regeneration 60
- Anion suppressor 83
- Cation suppressor 85
- Rinse
- Guard column 52, 53
 - Pump tubing 90
 - Sample path 93
 - Separation column 56
- Rinsing
- Separation column 54
- Rinsing time 94
- S**
-
- Safety instructions 6
- Safety shutdown 102
- Sample
- Carry-over 93
 - Sample loop 28
 - Transfer time 93
- Sample loop 28
- Sample path
- Rinse 93
- Sea level 101
- Separation column
- Installation 54
 - Protection 2, 27, 95
 - Regeneration 95
 - Rinse 56
 - Rinsing 54
 - Separating efficiency 94
 - Storage 95
- Service 6, 60
- Shutting down 61
- Storage 101
- Supply voltage 7
- Suppression rotor
- see Suppressor 83, 85
- Suppressor
- Clean 85
 - Install rotor 30
 - Installation 30
 - Maintenance 81
 - Operation 81
 - Replacing parts 88
 - Switching 81
 - Technical specifications 103
- Suppressor drive
- see "Suppressor" 30
- T**
-
- Technical specifications
- Detector 104
 - High-pressure pump 102
 - Injection valve 103
 - Interfaces 104
 - Leak sensor 102
 - MCS 103
 - Peristaltic pump 103
 - Reference conditions 101
 - Suppressor 103
 - Temperature 101
 - Transfer time 93
 - Transport locking screws 18
- Tubings
- Installation 15
- U**
-
- USB 104
- V**
-
- Vacuum pump
- Protection 19
- Valve
- See also "Injection valve" 28
- Voltage 104