

930 Compact IC Flex



930 Compact IC Flex ChS

Manual

8.930.8003EN / v3 / 2023-12-31



Metrohm AG
CH-9100 Herisau
Switzerland
Phone +41 71 353 85 85
Fax +41 71 353 89 01
info@metrohm.com
www.metrohm.com

930 Compact IC Flex

930 Compact IC Flex ChS

2.930.1200

Manual

Technical Communication
Metrohm AG
CH-9100 Herisau
techcom@metrohm.com

This documentation is protected by copyright. All rights reserved.

This documentation has been prepared with great care. However, errors can never be entirely ruled out. Please send comments regarding possible errors to the address above.

Table of contents

1	Introduction	1
1.1	Instrument description	1
1.2	Intended use	3
1.3	Safety instructions	3
1.3.1	General notes on safety	3
1.3.2	Electrical safety	3
1.3.3	Tubing and capillary connections	4
1.3.4	Flammable solvents and chemicals	5
1.3.5	Recycling and disposal	5
1.4	Symbols and conventions	5
2	Overview of the instrument	7
2.1	Front	7
2.2	Rear	8
2.3	Feed-throughs for capillaries and cables	10
3	Installation	13
3.1	Setting up the instrument	13
3.1.1	Packaging	13
3.1.2	Checks	13
3.1.3	Location	13
3.2	Capillary connections in the IC system	13
3.3	Removing transport locking screws	16
3.4	Connecting the drainage tubing and leak sensor	17
3.4.1	Installing the drainage tubing	17
3.4.2	Connecting the leak sensor	19
3.5	Connecting the eluent bottle	19
3.6	Installing the high-pressure pump	24
3.7	Installing an inline filter	25
3.8	Installing the pulsation absorber	25
3.9	Injection valve	26
3.10	Metrohm Suppressor Module (MSM)	28
3.10.1	Inserting the rotors	29
3.10.2	Connecting the Metrohm Suppressor Module (MSM)	32
3.11	Installing the conductivity detector	36
3.12	Installing the amperometric detector	37

3.13	Connecting the instrument to a computer	38
3.14	Connecting the instrument to the power grid	39
3.15	Initial start-up	40
3.16	Connecting and rinsing the guard column	42
3.17	Connecting the separation column	44
3.18	Conditioning	47
4	Operation	49
5	Operation and maintenance	50
5.1	IC system	50
5.1.1	Operation	50
5.1.2	Care	50
5.1.3	Maintenance by Metrohm Service	50
5.1.4	Shutting down and recommissioning	51
5.2	Capillary connections	52
5.3	Servicing the door	52
5.4	Handling the eluent	52
5.4.1	Manufacturing eluent	53
5.4.2	Changing the eluent	53
5.5	Notes on operating the high-pressure pump	54
5.6	Servicing the high-pressure pump	54
5.7	Servicing the inline filter	68
5.8	Servicing the pulsation absorber	71
5.9	Injection valve	71
5.10	Metrohm Suppressor Module (MSM)	71
5.10.1	Notes for operating the Metrohm Suppressor Module (MSM)	71
5.10.2	Taking care of the suppressor housing	72
5.10.3	Servicing the Metrohm Suppressor Module (MSM)	72
5.11	Servicing the detector	80
5.12	Rinsing the sample path	80
5.13	Separation column	82
5.13.1	Separating efficiency	82
5.13.2	Protecting the separation column	82
5.13.3	Storing the separation column	82
5.13.4	Regenerating the separation column	82
6	Troubleshooting	84
6.1	84

7	Technical specifications	88
7.1	Reference conditions	88
7.2	Ambient conditions	88
7.3	Housing	88
7.4	Weight	89
7.5	Leak sensor	89
7.6	High-pressure pump	89
7.7	Injection valve	90
7.8	Metrohm Suppressor Module (MSM)	90
7.9	Detector	90
7.10	Energy supply	90
7.11	Interfaces	91
8	Accessories	92
	Index	93



Table of figures

Figure 1	Front	7
Figure 2	Rear	8
Figure 3	Feed-throughs on the door	10
Figure 4	Openings for capillaries and cables	11
Figure 5	Ducts for capillaries	12
Figure 6	Removing the transport locking screws	16
Figure 7	Installing the eluent bottle cap	20
Figure 8	Installing the tubing weighting and aspiration filter	22
Figure 9	High-pressure pump with purge valve	24
Figure 10	Inline filter	25
Figure 11	Pulsation absorber	26
Figure 12	Exchanging the sample loop	27
Figure 13	Metrohm Suppressor Module (MSM) – Connection capillaries	32
Figure 14	High-pressure pump – Parts	55
Figure 15	High-pressure pump – Cross-section	62
Figure 16	Tool for piston seal (6.2617.010)	63
Figure 17	Removing the piston cartridge from the pump head	63
Figure 18	Inserting the piston seal into the tool	64
Figure 19	Parts of the piston cartridge	65
Figure 20	Inline filter – Removing the filter	69
Figure 21	Parts of the Metrohm Suppressor Module (MSM)	72

1 Introduction

1.1 Instrument description

The 930 Compact IC Flex is a robust ion chromatograph. It is distinguished by:

- Its intelligence: All of the functions are monitored, optimized and documented in an FDA-compatible manner. Intelligent components, such as iColumns, save important data onto a chip.
- Its compact design: It has a small footprint.
- Its transparency: All components are easily accessible and located for simple visibility and can be monitored during operation through a large window.
- Its safety: The wet end and the electronics are physically separated, thereby preventing fluids from coming into contact with the electronics to a large extent. A leak sensor is integrated into the wet end.
- Its environmental compatibility.
- Its low noise emission.
- The intelligent MagIC Net software.

The 930 Compact IC Flex is operated using the MagIC Net software. A USB cable is used to connect the instrument to a computer with MagIC Net installed. The intelligent software detects the instrument automatically and checks its functionality. The software controls and monitors the instrument, evaluates the measured data and manages it in a database.

The 930 Compact IC Flex ChS consists of the following modules:

Housing

The sturdy housing contains the instrument's electronic components, including their interfaces and one connector for a separation column. In addition, the housing provides space for a conductivity detector or an amperometric detector. Capillaries and cables can be fed into and out of the instrument through several openings.

Leak sensor

The leak sensor detects leaking liquid that collects in the instrument's base tray. Liquid that leaks in the instrument is routed to the base tray using drainage tubing and detected there.



High-pressure pump

The intelligent and low-pulsation high-pressure pump pumps the eluent through the IC system. It is equipped with a chip where its technical specifications and "life history" (operating hours, service data, etc.) are stored.

Inline filter

Inline filters protect the separation column reliably from potential contamination from the eluent. The filter pads with 2 µm pore size can be replaced quickly and easily. They remove particles from the solutions, such as bacteria and algae.

Pulsation absorber

The pulsation absorber protects the separation column from damage caused by pressure fluctuations, e.g. when the injection valve is switched, and reduces interfering pulsations during highly sensitive measurements.

Injection valve

The injection valve connects the eluent path to the sample path. By a quick and precise switching of the valve, a quantity of sample solution defined by the size of the sample loop is injected and flushed to the separation column with the eluent.

Metrohm Suppressor Module (MSM)

The chemical suppressor MSM consists of the suppressor drive, a rotor and, where applicable, an adapter. The suppressor drive gives you the flexibility to use different rotors according to the principle "one drive – many rotors". Suppression rotors with different capacities and construction or a rotor for sample preparation (SPM Rotor) are readily interchangeable with appropriate adapters as needed. The rotors are not included in the instrument's scope of delivery. The rotor required for the application and any adapter that is required must be ordered separately.

Detector

Metrohm offers a series of different detectors for various analysis tasks. A suitable detector type must be ordered as a separate device.

Separation column

The intelligent separation column separates different components according to their interactions with the column. Metrohm separation columns are equipped with a chip where their technical specifications and history (start-up, operating hours, injections etc) are stored.

1.2 Intended use

The 930 Compact IC Flex ChS is used for the determination of anions or polar substances with chemical suppression using ion chromatography.

It can also be used as needed for the determination of cations, polar substances or anions without chemical suppression.

This instrument is suitable for processing chemicals and flammable samples. Therefore, the use of the 930 Compact IC Flex requires the user to have basic knowledge and experience in handling toxic and caustic substances. Knowledge regarding the application of fire prevention measures prescribed for laboratories is also mandatory.

1.3 Safety instructions

1.3.1 General notes on safety



WARNING

Operate this instrument only according to the information contained in this documentation.

This instrument left the factory in a flawless state in terms of technical safety. To maintain this state and ensure non-hazardous operation of the instrument, the following instructions must be observed carefully.

1.3.2 Electrical safety

The electrical safety when working with the instrument is ensured as part of the international standard IEC 61010.



WARNING

Only personnel qualified by Metrohm are authorized to carry out service work on electronic components.



WARNING

Never open the housing of the instrument. The instrument could be damaged by this. There is also a risk of serious injury if live components are touched.

There are no parts inside the housing which can be serviced or replaced by the user.



Supply voltage



WARNING

An incorrect supply voltage can damage the instrument.

Only operate this instrument with a supply voltage specified for it (see rear panel of the instrument).

Protection against electrostatic charges



WARNING

Electronic components are sensitive to electrostatic charges and can be destroyed by discharges.

Do not fail to pull the power cord out of the power socket before you set up or disconnect electrical plug connections at the rear of the instrument.

The device is to be operated only with the door closed.

1.3.3 Tubing and capillary connections



CAUTION

Leaks in tubing and capillary connections are a safety risk. Tighten all connections well by hand. Avoid applying excessive force to tubing connections. Damaged tubing ends lead to leakage. Appropriate tools can be used to loosen connections.

Check the connections regularly for leakage. If the instrument is used mainly in unattended operation, then weekly inspections are mandatory.

1.3.4 Flammable solvents and chemicals



WARNING

All relevant safety measures are to be observed when working with flammable solvents and chemicals.

- Set up the instrument in a well-ventilated location (e.g. fume cupboard).
- Keep all sources of flame far from the workplace.
- Clean up spilled liquids and solids immediately.
- Follow the safety instructions of the chemical manufacturer.

1.3.5 Recycling and disposal

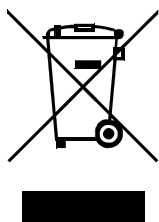

Properly dispose of chemicals and of the product to reduce negative effects on the environment and public health. Local authorities, waste disposal companies or dealers provide more detailed information on disposal. Observe the WEEE EU directive (WEEE = Waste Electrical and Electronic Equipment) for the proper disposal of waste electronic equipment within the European Union.

1.4 Symbols and conventions

The following symbols and formatting may appear in this documentation:

(5-12)	Cross-reference to figure legend The first number refers to the figure number, the second to the instrument part in the figure.
1	Instruction step Carry out these steps in the sequence shown.
Method	Dialog text, parameter in the software
File ► New	Menu or menu item
[Next]	Button or key
	WARNING This symbol draws attention to a possible life-threatening hazard or risk of injury.
	WARNING This symbol draws attention to a possible hazard due to electrical current.



WARNING

This symbol draws attention to a possible hazard due to heat or hot instrument parts.



WARNING

This symbol draws attention to a possible biological hazard.



CAUTION

This symbol draws attention to possible damage to instruments or instrument parts.



NOTE

This symbol highlights additional information and tips.

2 Overview of the instrument

2.1 Front

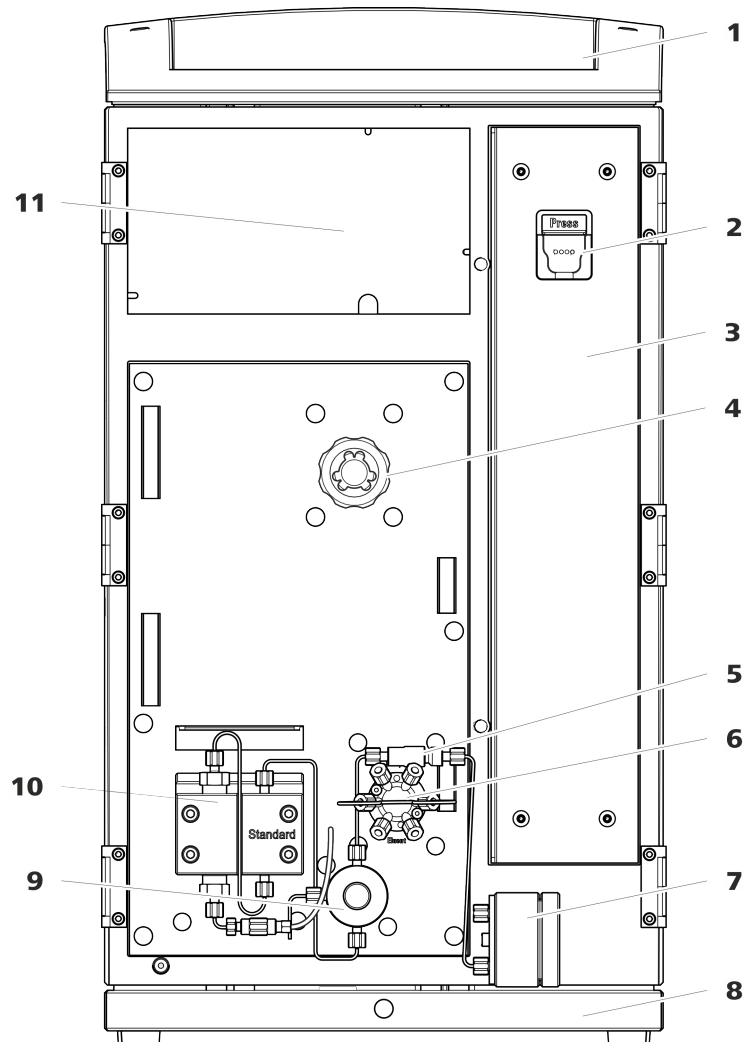

Figure 1 Front

1 Bottle holder

Offers space for the eluent bottle and additional accessories.

3 Column chamber

5 Inline filter

7 Pulsation absorber

2 Column holder

For hanging the separation column (iColumn). With column recognition.

4 Metrohm Suppressor Module (MSM)

6 Injection valve

8 Base tray

With leak sensor.



9 Purge valve

For deaerating the high-pressure pump. With rotary knob in the center and pressure sensor.

10 High-pressure pump

Pumps the eluent through the IC system.

11 Detector chamber

Offers space for an embedded detector and additional accessories.

2.2 Rear

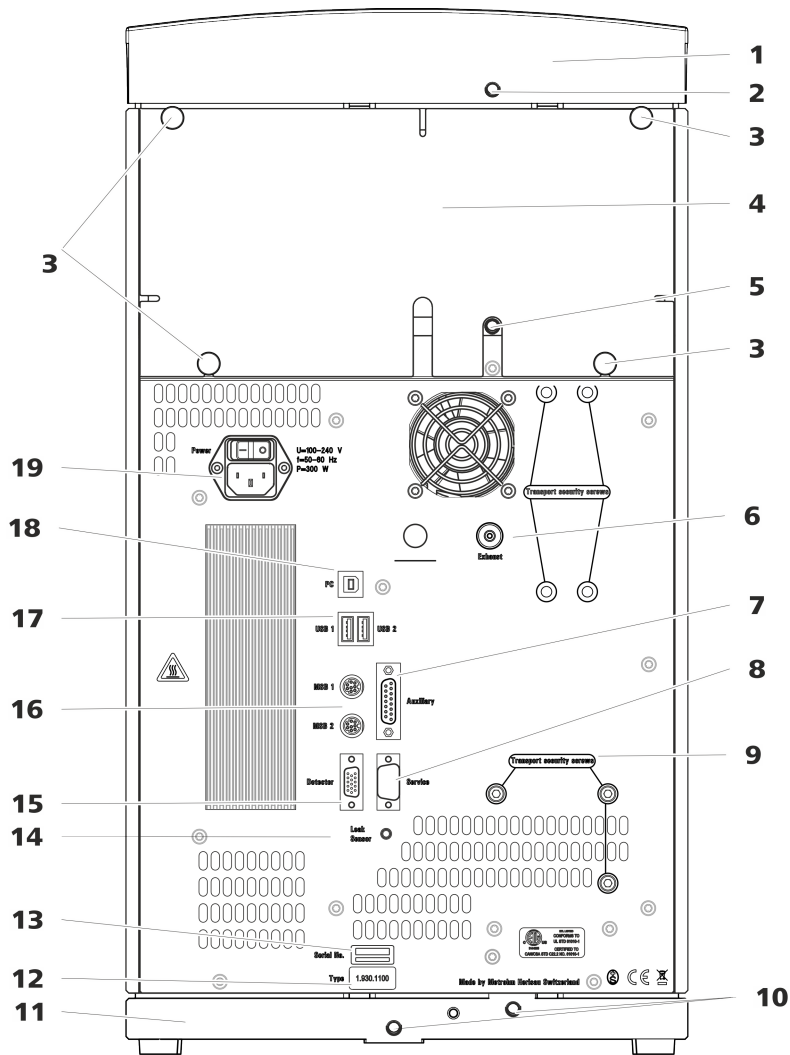

Figure 2 Rear

1 Bottle holder

2 Drainage tubing connection

For connecting the drainage tubing, which guides escaped fluids away from the bottle holder.



<p>3 Knurled screws For fastening the removable back panel.</p>	<p>4 Back panel Removable. Enables access to the detector chamber.</p>
<p>5 Drainage tubing connection For connecting the drainage tubing, which guides escaped liquids away from the detector chamber.</p>	<p>6 Exhaust opening Labeled <i>Exhaust</i>. For extracting the air from the vacuum chamber.</p>
<p>7 Auxiliary connection socket For connecting an 891 Professional Analog Out (2.891.0010).</p>	<p>8 Service connection socket For Metrohm service only.</p>
<p>9 Transport locking screws For securing the high-pressure pump when transporting the instrument.</p>	<p>10 Drainage tubing connections For connecting two drainage tubings that guide the escaped fluid to the leak sensor and from there to the waste container.</p>
<p>11 Base tray With leak sensor.</p>	<p>12 Type plate</p>
<p>13 Serial number</p>	<p>14 Leak sensor connection socket Labeled <i>Leak Sensor</i>. For connecting the leak sensor connection cable.</p>
<p>15 Detector connection socket Labeled <i>Detector</i>. For connecting Metrohm detectors.</p>	<p>16 MSB connection sockets Labeled <i>MSB 1</i> and <i>MSB 2</i>. For connecting MSB devices.</p>
<p>17 USB connection sockets Labeled <i>USB 1</i> and <i>USB 2</i>. For connecting USB devices.</p>	<p>18 PC connection socket For connecting the instrument to the computer with the USB cable (6.2151.020).</p>
<p>19 Power socket Power socket for connecting the power cable and power switch for switching the instrument on and off.</p>	

2.3 Feed-throughs for capillaries and cables

Multiple openings are available for leading capillaries into the instrument and for leading capillaries and cables out of the instrument:

- Openings on the door
- Openings on the back panel
- Ducts between the instrument and the base tray as well as between the instrument and the bottle holder (see figure 5, page 12)

Openings on the door

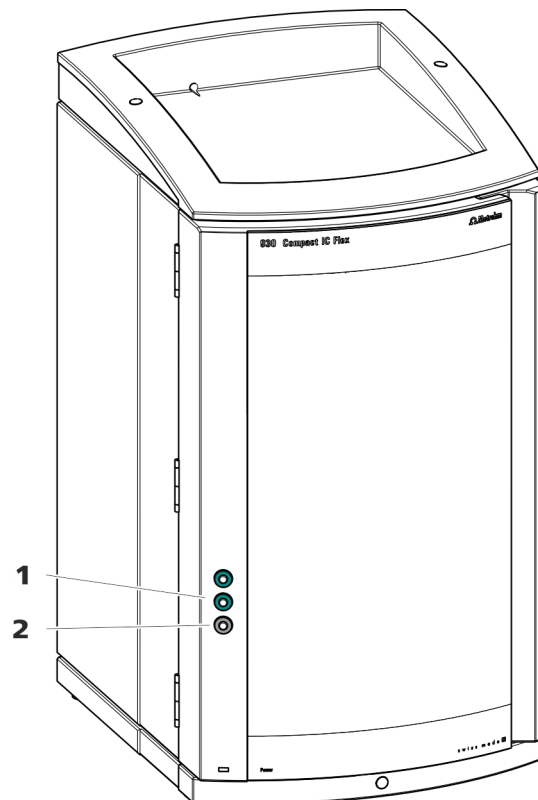

Figure 3 Feed-throughs on the door

1 Luer connector

For connecting a capillary from inside and for inserting a syringe (6.2816.020) from outside. For manual sample injection.

2 Opening for capillaries

For up to 3 capillaries.

An opening for up to 3 capillaries is located on the door of the instrument.

The two Luer connections above are not actually openings; the capillaries are fastened to the Luer connection from within using PEEK pressure screws. You can use a syringe to inject or draw out liquid from the outside.

Openings on the back panel

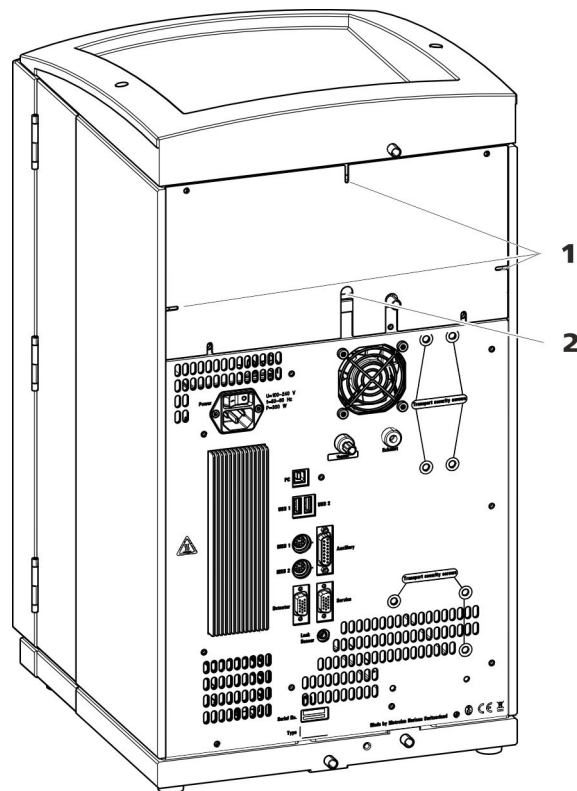

Figure 4 Openings for capillaries and cables

1 Openings for capillaries

2 Openings for cables

The removable back panel is outfitted with openings through which capillaries and cables can be lead out of the detector chamber.

Ducts for capillaries

There are ducts for capillaries between the instrument and base tray as well as between the instrument and the bottle holder. The capillaries can be fed to the front of the instrument from both sides of the instrument and from the front of the instrument to the back of the instrument.

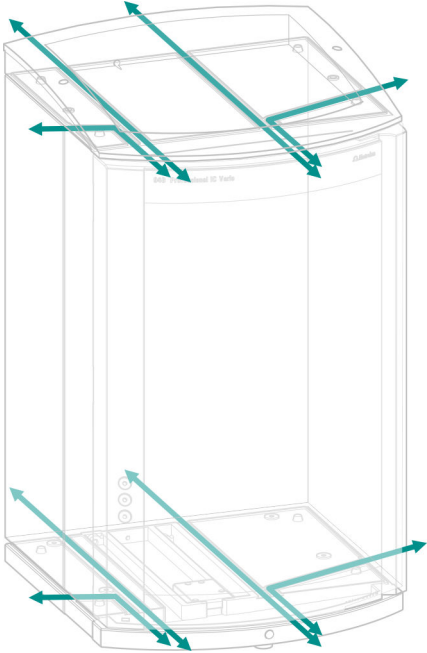

Figure 5 Ducts for capillaries

3 Installation

3.1 Setting up the instrument

3.1.1 Packaging

The instrument is supplied in protective packaging together with the separately packed accessories. Keep this packaging, as only this ensures safe transportation of the instrument.

3.1.2 Checks

Immediately after receipt, check whether the shipment has arrived complete and without damage by comparing it with the delivery note.

3.1.3 Location

The instrument has been developed for operation indoors and may not be used in explosive environments.

Place the instrument in a location of the laboratory which is suitable for operation, free of vibrations, protected from corrosive atmosphere, and contamination by chemicals.

The instrument should be protected against excessive temperature fluctuations and direct sunlight.

3.2 Capillary connections in the IC system

Generally speaking, capillary connections between two components of an IC system are made up of one connection capillary and two pressure screws used to connect the capillary to the respective components.

Pressure screws

Three types of pressure screws are used in the IC system:

Number	Designation	Use
6.2744.010 / 6.2744.014	Pressure screw	On the injection valve
6.2744.070	Pressure screw, short	High-pressure pump, purge valve, inline filter, pulsation absorber, separation columns
6.2744.090	Pressure screw, long	MCS, sample degasser, 10-port valve

Pressure screws are tightened and loosened by hand. A tool is not needed.

occurs if two capillary ends connected to each other do not fit exactly, thus allowing liquid to escape. There are two possible causes for this:

- The capillary ends do not have exactly flat edges.
- The two capillary ends do not completely meet.

One prerequisite for dead-volume-free capillary connection is that both capillary ends are cut exactly flat. Therefore we recommend cutting PEEK capillaries only with a capillary cutter (6.2621.080).

Also see: *Cutting capillaries* video on the Internet <http://ic-help.metrohm.com>.

Creating dead-volume-free capillary connections

To create dead-volume-free capillary connections, proceed as follows:

- 1** Wipe off the end of the capillary with a cloth dampened with acetone.
- 2** Slide the pressure screw over the capillary. Ensure that the capillary protrudes 1 to 2 mm from the tip of the pressure screw.
- 3** Push the capillary into the connection or coupling as far as it will go and hold it there.
- 4** Only then start turning the pressure screw. Hold the capillary in the stop position while turning it shut.

Colored sleeves for PEEK capillaries

The enclosed set of varicolored sleeves for PEEK capillaries (6.2251.000) serves to easily differentiate the various flows of liquid in the system through color coding. Each capillary conveying a given liquid (e.g. eluent) can be marked with sleeves of the same color.

- 1** Slide a colored sleeve of a selected color over a capillary and move it to an easily visible position.
- 2** Heat the colored sleeve, e.g. with a hairdryer.

The colored sleeve shrinks and adapts to the shape of the capillary.



NOTE

In order to arrange capillaries more clearly, they can be bundled with the spiral band (6.1815.010).

3.3 Removing transport locking screws

To avoid damage to the drives for the high-pressure pump and the vacuum pump during transport, the pumps are secured with transport locking screws. These are located at the rear of the instrument and labeled with **Transport security screws**.

Remove these transport locking screws before the initial start-up.

Accessories

For this step you need:

- 4 mm hex key (6.2621.030)

Removing the transport locking screws

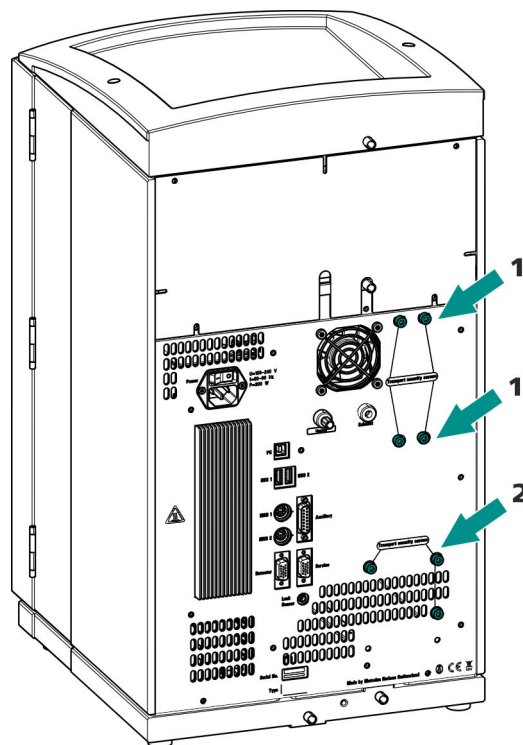

Figure 6 Removing the transport locking screws

1 Transport locking screws

For the vacuum pump. Only present if the instrument has a degasser or a CO₂ Suppressor (MCS).

2 Transport locking screws

For the high-pressure pump.

- 1 Remove all of the transport locking screws with the hex key.

Store the transport locking screws in a safe place. Reinsert the transport locking screws each time you transport the instrument a significant distance.



CAUTION

The pumps may be damaged if you transport the instrument without inserting the transport locking screws.

3.4 Connecting the drainage tubing and leak sensor

The leak sensor detects leaking liquid that collects in the instrument's base tray. Liquid that leaks in the bottle holder or in the detector chamber is conveyed to the base tray using drainage tubing and is detected there.

If the leak sensor detects a leak in the IC system, the IC instrument is switched off. The software displays a warning.

The leak sensor functions properly only if the following preconditions are met:

- The drainage tubing is connected.
- The leak sensor connection cable is inserted into the leak sensor connection socket.
- The 930 Compact IC Flex is switched on.
- The leak sensor is switched to **active** in the software.

3.4.1 Installing the drainage tubing

Liquid that leaks in the bottle holder or detector chamber flows to the rear of the instrument. Openings on the bottle holder and in the detector chamber allow the liquid to drain. The drainage tubing has to be mounted at these openings. This drainage tubing guides the leaking liquid to the base tray where the leak sensor is located.

Accessories

For this step you need the following parts from the accessory kit: Vario/Flex Basic (6.5000.000):

- 2 × silicone tubing (6.1816.020)
- Y connector (6.1807.010)

You also need scissors.



Connecting the drainage tubing

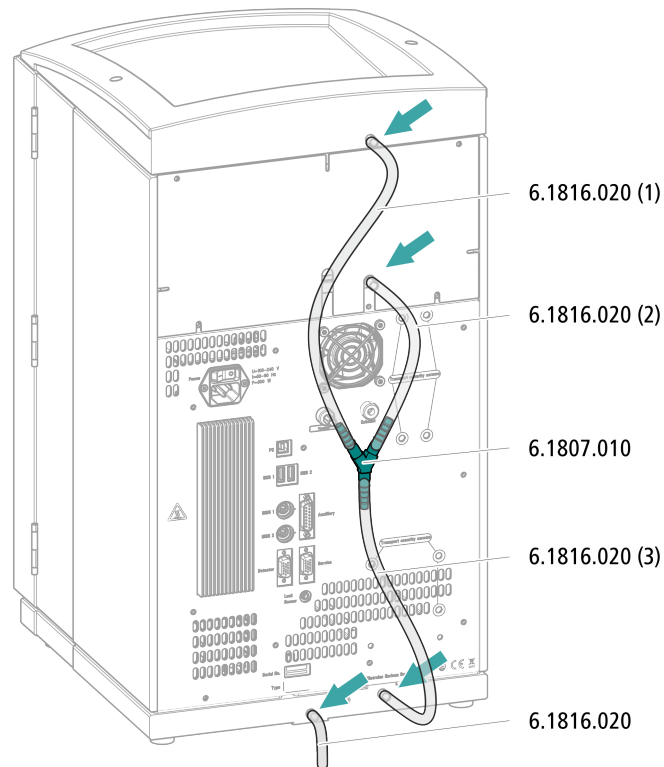

- 1** Cut a piece of silicone tubing into three pieces using scissors: 2 × approx. 40 cm and 1 × 20 cm.
- 2** Attach one end of the 40 cm long piece to the drainage tubing connection on the bottle holder.
- 3** Attach one end of the 20 cm long piece to the drainage tubing connection on the detector chamber.
- 4** Attach each of the loose ends of both pieces of silicone tubing to one end of the Y connector.
- 5** Attach one end of the second 40 cm long piece to the third end of the Y connector.
Attach the loose end to the right-side drainage tubing connection on the base tray.
- 6** Attach one end of the second piece of silicone tubing to the left-side drainage tubing connection on the base tray.

Route the loose end into a waste container.

3.4.2 Connecting the leak sensor

Plugging in the leak sensor connection cable

The leak sensor connection cable is coiled up in the base tray.

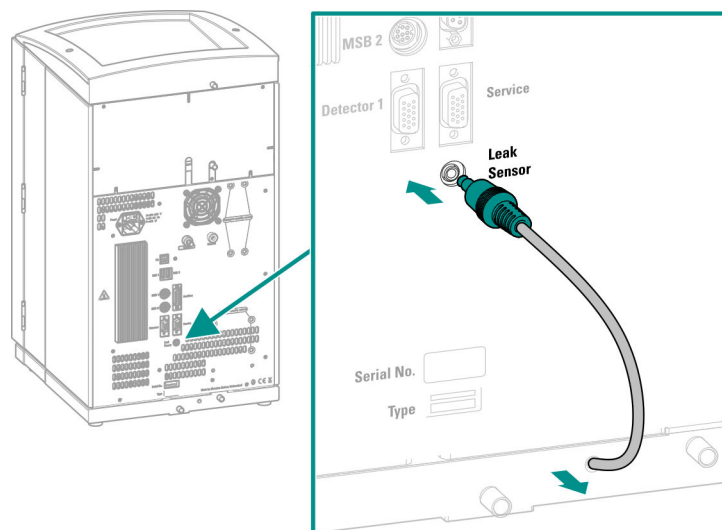

- 1 Pull the leak sensor connection cable out of the base tray as far as needed.
- 2 Plug the plug for the leak sensor connection cable into the leak sensor connection socket (labeled **Leak Sensor**).

3.5 Connecting the eluent bottle

The eluent is aspirated out of the eluent bottle via the eluent aspiration tubing. The eluent aspiration tubing is installed on the entry to the high-pressure pump.

The tubing must be fed out of the instrument through a suitable opening (see "Openings on the back panel", page 11) before the loose end can be connected to the eluent bottle.

Accessories

For this step, you need the following accessories:

These parts are part of the *Vario/Flex ONE* accessory kit (6.5000.010).

- Eluent bottle (6.1608.070)



- The *eluent bottle cap GL 45* accessory set (6.1602.160)
This accessory set contains the bottle cap, an M6 tubing nipple, an M8 tubing nipple, two O-rings and an M6 and M8 threaded stopper.
- The *tubing adapter for aspiration filter* accessory set (6.2744.210)
This accessory set contains a filter holder, a clamping screw and tubing weighting.
- An aspiration filter (6.2821.090)
- The adsorber tube (6.1609.000)
- The SGJ clip (6.2023.020)

Connecting the eluent aspiration tubing

1 Installing the eluent bottle cap (6.1602.160)

- Start by pushing the M8 tubing nipple onto the loose end of the eluent aspiration tubing, followed by the O-ring.
- Push the loose end of the eluent aspiration tubing through the M8 opening of the bottle cap and screw it on for the time being.

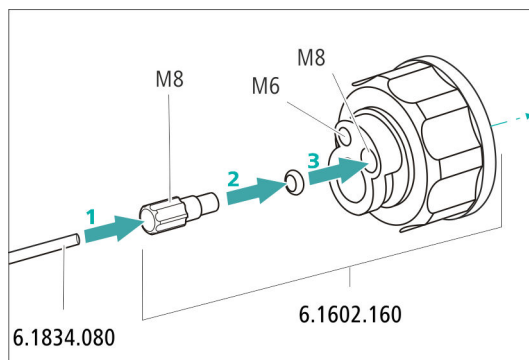

Figure 7 Installing the eluent bottle cap

2 Mounting the tubing adapter

Install the parts of the *tubing adapter for aspiration filter* (6.2744.210) accessory set:

- Start by pushing the tubing weighting onto the loose end of the eluent aspiration tubing.
- Then push the clamping screw onto the loose end of the eluent aspiration tubing.
- Lastly, push the filter holder onto the loose end of the eluent aspiration tubing and screw it onto the tubing nipple.
The end of the tubing should extend approximately 1 cm.

3 Pre-rinsing the aspiration filter



NOTE

Always wear gloves when handling the aspiration filter.

In order to avoid air bubbles after the installation of the aspiration filter, we recommend pre-rinsing the aspiration filter with ultrapure water or eluent.

For pre-rinsing, you will need the adapter Luer inner, M6 outer (6.02744.050), a syringe and a vessel with ultrapure water or eluent.

- Screw the adapter to the aspiration filter.
- Insert the syringe into the adapter.

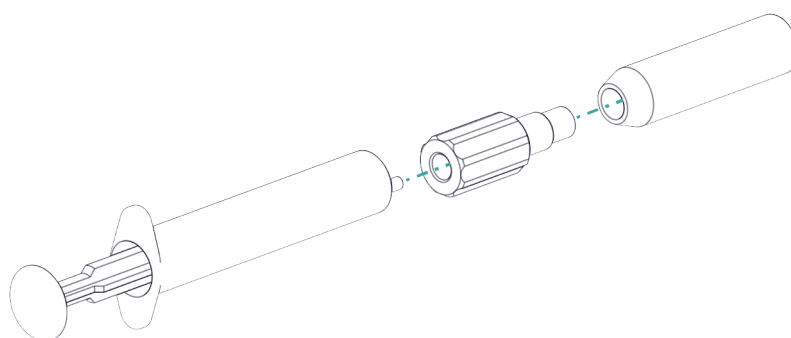

- Immerse the aspiration filter in a vessel with ultrapure water or eluent.
- Fill the syringe completely with ultrapure water or eluent 3 times and then empty it again each time.

4 Mounting the aspiration filter



NOTE

Always wear gloves when handling the aspiration filter.

- Place the loose end of the eluent aspiration tubing into the aspiration filter.
The end of the tubing should reach approximately to the center of the aspiration filter.
- Tighten the aspiration filter to the filter holder.

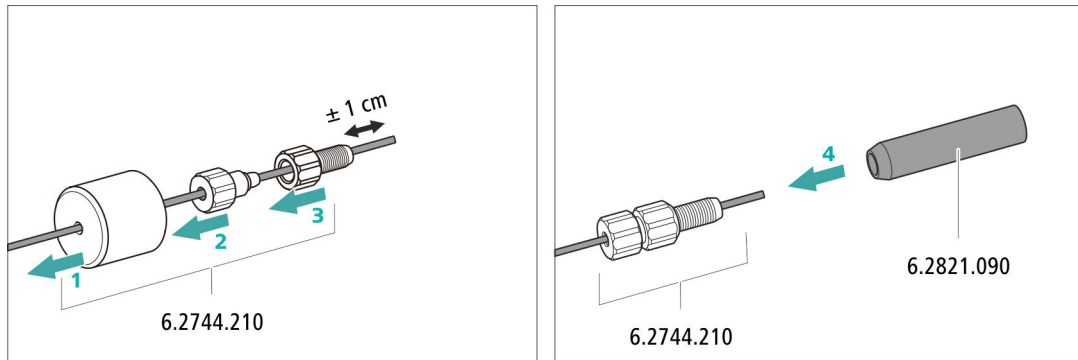
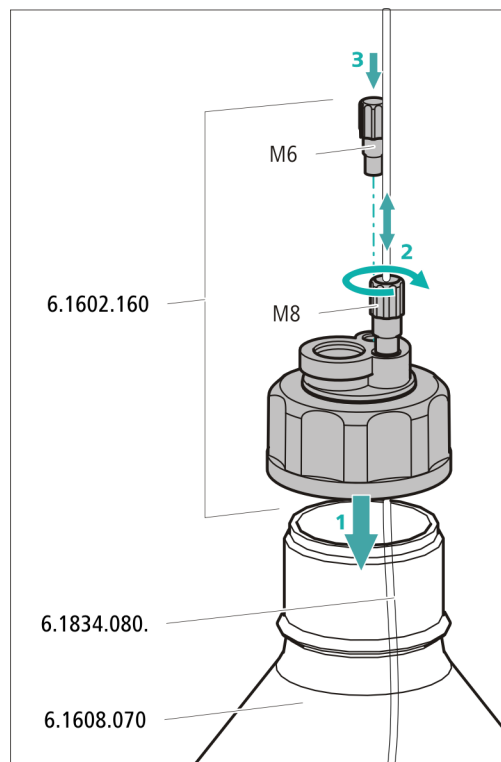

Figure 8 Installing the tubing weighting and aspiration filter

5 Installing the eluent bottle cap on the eluent bottle

- Insert the eluent aspiration tubing into the eluent bottle (6.1608.070).
- Tighten the bottle cap on the eluent bottle.
- Adjust the length of the eluent aspiration tubing so that the aspiration filter is at the bottom of the eluent bottle. Then fix it in place using the M8 tubing nipple.
- Seal the M6 opening on the bottle cap with the M6 threaded stopper from the accessory set.



6 Mounting the adsorber tube



NOTE

Depending on the eluent used, the adsorber tube (6.1609.000) must be filled differently:

- For alkaline eluents or eluents with a low buffer capacity: first a little cotton, then with CO₂ adsorber material.
 - For all other eluents: only with cotton.
- Remove the plastic cover from the large opening of the adsorber tube. Fill the adsorber tube and close it again using the plastic cover.
 - Insert the adsorber tube into the bottle cap's large opening. Fasten it to the bottle cap using the ground-joint clip (6.2023.020).

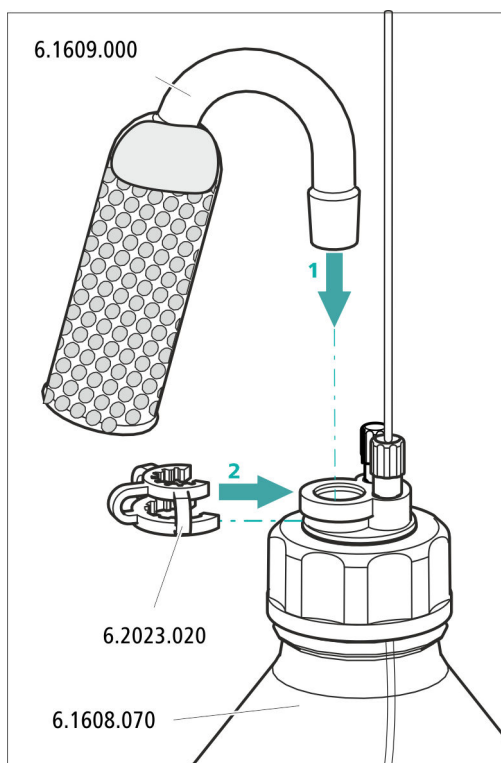



3.6 Installing the high-pressure pump

The intelligent and low-pulsation high-pressure pump pumps the eluent through the system. It is equipped with a chip where its technical specifications and "life history" (operating hours, service data, etc.) are saved.

The high-pressure pump consists of:

- The pump head, which pumps the eluent through the system.
- The purge valve used for bleeding the pump head.

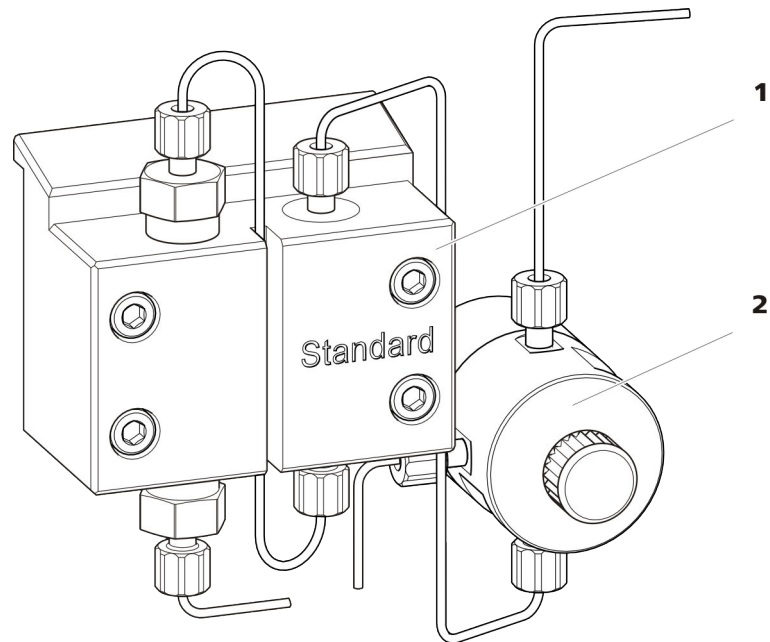

Figure 9 High-pressure pump with purge valve

1 Pump head

2 Purge valve

The high-pressure pump is completely connected. No installation work is required.

3.7 Installing an inline filter

Inline filters protect the separation column reliably from potential contamination from the eluent. The small filter pads with 2 µm pore size can be replaced quickly and easily. They remove particles from the solutions.

An inline filter (6.2821.120) is installed between the purge valve and the pulsation absorber as protection against particles.

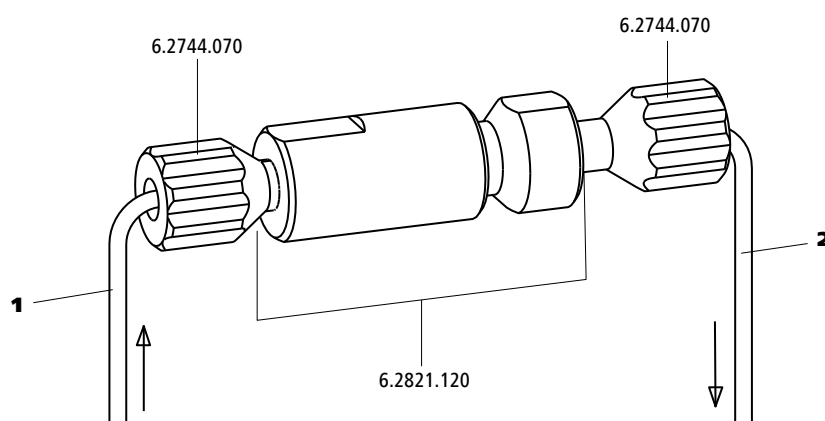

Figure 10 Inline filter

1 Inlet capillary

Connected to the purge valve.

2 Outlet capillary

Connected to the pulsation absorber.

The inline filter is completely connected. No installation work is required.

3.8 Installing the pulsation absorber

The pulsation absorber is installed between the high-pressure pump and the injection valve. It protects the separation column from damage caused by pressure fluctuations, e.g. when the injection valve is switched, and reduces interfering pulsations during highly sensitive measurements.

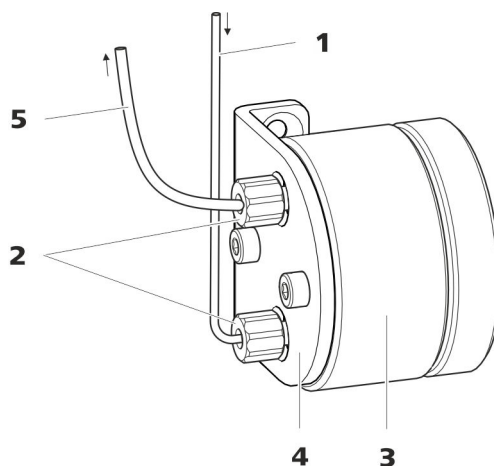

Figure 11 Pulsation absorber

1	Connection capillary Connection to inline filter.	2	PEEK pressure screws, short (6.2744.070)
3	Pulsation absorber (6.2620.150)	4	Holder for pulsation absorber
5	Connection capillary Connection to injection valve.		

The pulsation absorber is completely connected. No installation work is required.

3.9 Injection valve

The injection valve connects the eluent path to the sample path. By a quick and precise switching of the valve a defined quantity of sample solution is injected and flushed to the separation column with the eluent.

The quantity of sample solution injected is determined by:

- the volume of the sample loop or
- by an 800 Dosino when the Metrohm intelligent Partial Loop Injection Technique (MiPT) is used.

The choice of sample loop depends on the application. The following sample loops are normally used:

Table 1 Which sample loop do I need?

Application	Sample loop
Cation determination	20 µL
Anion determination with suppression	20 µL
Anion determination without suppression	100 µL
MiPT	250 µL

Application**Sample loop**

The injection valve is completely connected. No installation work is required.

Optional: Exchanging the sample loop

The sample loop can be replaced to match the application (see table 1, page 26).

**NOTE**

Only use PEEK pressure screws (6.2744.010) to connect capillaries and the sample loop to the injection valve.

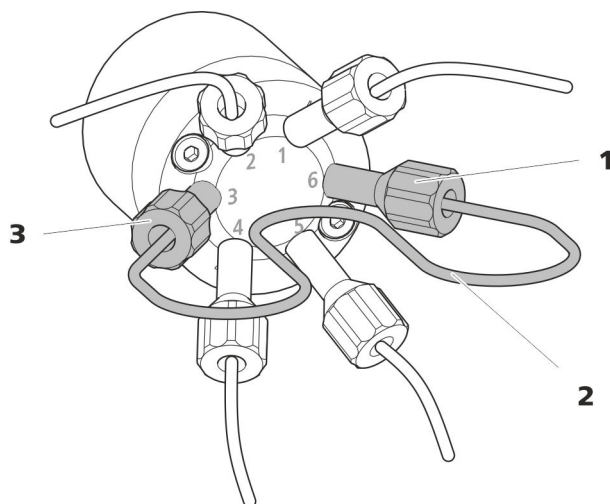

Figure 12 Exchanging the sample loop

1 Pressure screw
Fastened to Port 6.

2 Sample loop

3 Pressure screw
Fastened to Port 3.

Exchanging the sample loop



NOTE

Observe a dead-volume-free installation of the sample loop (see "Creating dead-volume-free capillary connections", page 15).

1 Removing the existing sample loop

- Loosen the pressure screws (6.2744.010) at Port 3 and Port 6.
- Remove the sample loop.

2 Installing a new sample loop

- Fasten one end of the sample loop to Port 3 using a PEEK pressure screw (6.2744.010).
- Use the second PEEK pressure screw (6.2744.010) to fasten the other end of the sample loop to Port 6.

3.10 Metrohm Suppressor Module (MSM)

The suppressor drive of the 930 Compact IC Flex can hold various rotors. The large rotors, such as the MSM-HC Rotor A (6.2842.000) and the MSM-HC Rotor C (6.2842.200) can be inserted directly.

The small rotors, such as the MSM Rotor A (6.2832.000) and the MSM-LC Rotor A (6.2844.000), must first be fitted into the adapter (6.2842.020), which can then be inserted into the suppressor housing.

A connecting piece (6.2835.010) is used for all rotors for connecting the Metrohm Suppressor Module (MSM) to the IC system.

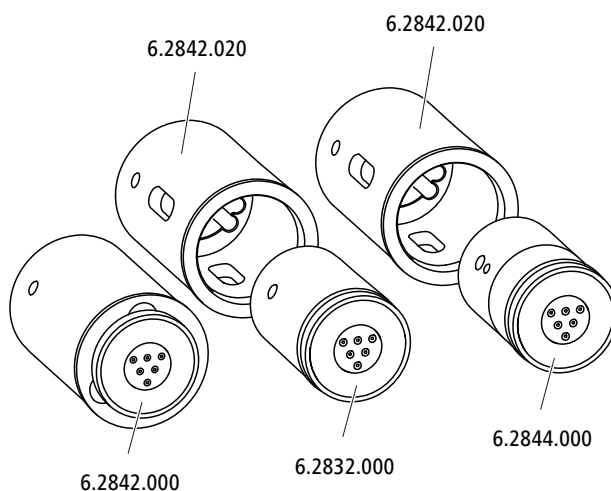

**NOTE**

The instruments are supplied without rotor and without adapter.
The suitable rotor and the adapter, if required, must be ordered separately.

3.10.1 Inserting the rotors*Accessories*

For this step, you need the following accessories:

- For suppression: MSM Rotor A (6.2832.000) or MSM-HC Rotor A (6.2842.000), MSM-LC Rotor A (6.2844.000) or MSM-HC Rotor C (6.2842.200) or MSM-HC Rotor C (6.2842.200)
- Optional: Adapter (6.2842.020)
- Connecting piece (6.2835.010)

Large rotors can be inserted directly into the rotor housing.

**CAUTION**

The rotor may be destroyed during start-up if not inserted correctly.
Therefore, follow the following instructions exactly.

Inserting large rotors

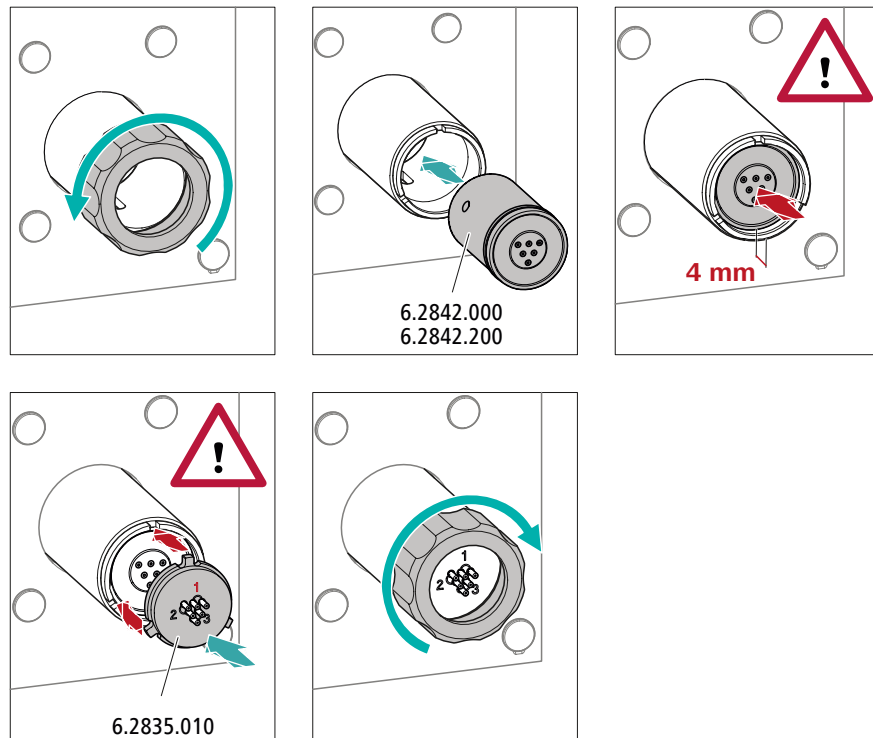

1 Removing the union nut

Loosen the union nut and remove it.

2 Inserting the rotor

- Clean the sealing surface of the rotor with ethanol using a lint-free cloth.
- Insert the rotor into the suppressor drive so that the tubing connections on the rear of the rotor fit into the corresponding recesses inside the suppressor drive and one of the three holes of the rotor is visible from below in the slot of the suppressor drive.



NOTE

The rotor's sealing surface is located approx. 4 mm deep inside the suppressor drive if the rotor is inserted correctly.

If this is not the case, then the rotor must be moved into the correct position using careful turning. If the rotor cannot be turned or removed, it can be moved into the correct position from below by means of a pointed object (e.g. a screwdriver).

3 Inserting the connecting piece

- Clean the sealing surface of the connecting piece with ethanol using a lint-free cloth.
- Insert the connecting piece into the suppressor drive so that connector 1 is on top and the three pins of the connecting piece fit into the corresponding recesses on the suppressor drive.

4 Attaching the union nut

Tighten the union nut on the thread of the suppressor drive by hand (do not use any tools).

Inserting small rotors

You need the adapter (6.2842.020) in order to insert a small rotor into the suppressor drive.

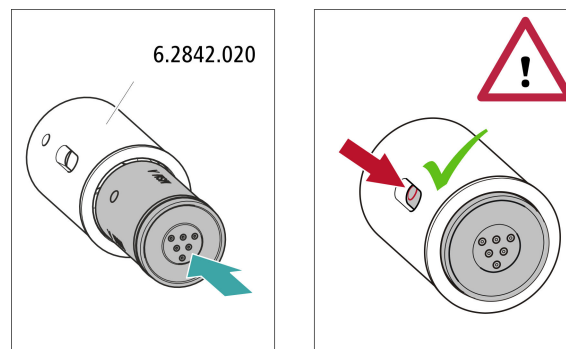

1 Inserting the rotor into the adapter



CAUTION

An incorrectly inserted rotor may be **destroyed** during start-up.

- Clean the sealing surface of the rotor with ethanol using a lint-free cloth.
- Insert the rotor into the adapter so that the tubing connections on the rear of the rotor fit into the corresponding recesses inside the adapter and one of the three holes of the rotor is visible in the slot of the adapter.

2 Inserting the adapter

Insert the adapter into the suppressor drive just like a large rotor (see "Inserting large rotors", page 30).

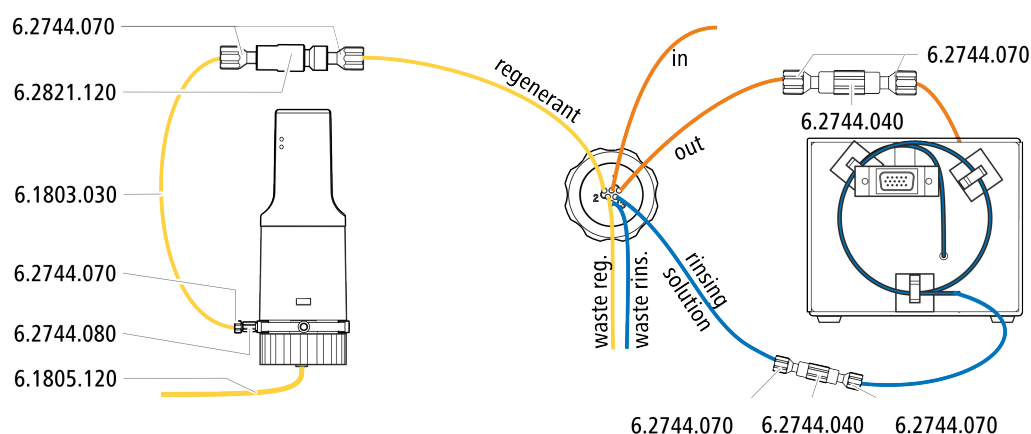
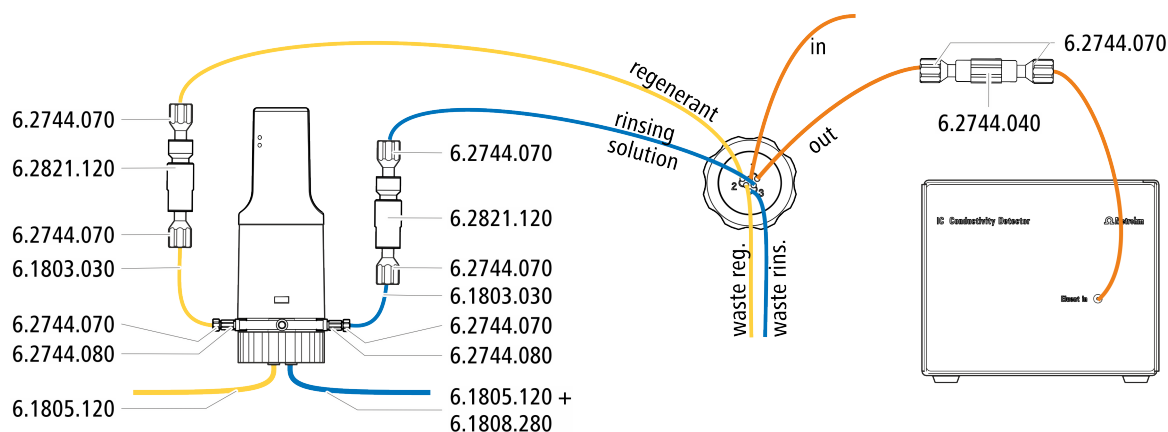
Recommended installation**Alternative installation****3.10.2.1 Installing the eluent path**

The eluent path is connected with the capillaries *in* and *out*.

- 1** Connect the capillary labeled *in* to the outlet of the separation column using a short pressure screw (6.2744.070).
- 2** Connect the capillary labeled *out* to the detector inlet capillary using one coupling (6.2744.040) and two pressure screws (6.2744.070) (see manual of the conductivity detector).

3.10.2.2 Installing bottles with auxiliary solutions*Accessories*

To connect the bottles of the auxiliary solutions, you will need the following accessories:

- Accessories from the accessory kit: IC Vario/Flex ChS (6.5000.030)
- Accessories from IC equipment: Dosino Regeneration (6.5330.190)

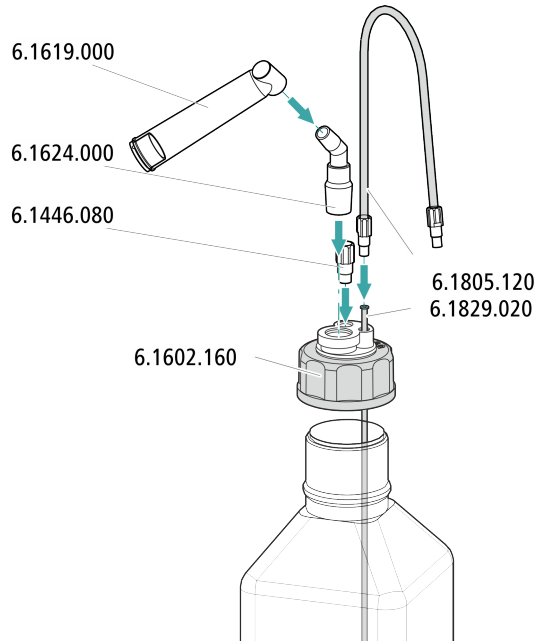

3.10.2.3 Connecting the regeneration solution

The regeneration solution is connected to the *regenerant* capillary.

Connecting the regeneration solution to a Dosino

For this step, you need the following accessories:

- Dosino (2.800.0010)
- Accessory kit: Flex/Vario: ChS (6.5000.030)
- IC equipment: Dosino Regeneration (6.5330.190)

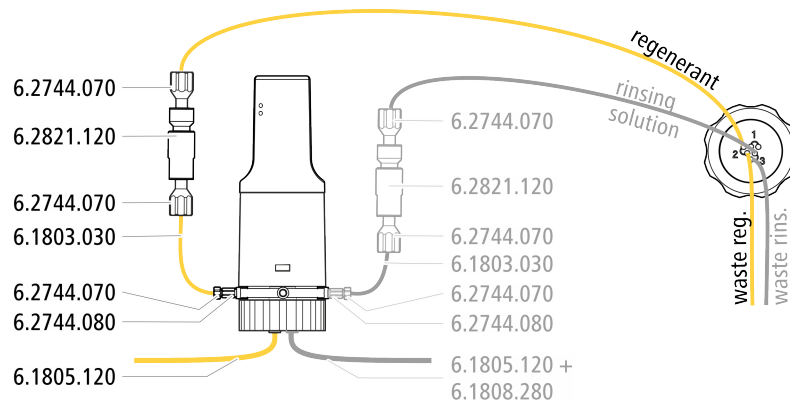

- 1** Connect the capillary labeled *regenerant* to the outlet of the inline filter (6.2821.120) using a pressure screw (6.2744.070).
- 2** Use a pressure screw (6.2744.070) to fasten a piece of the PTFE capillary (6.1803.030) to the inlet of the inline filter.

- 3 Use a pressure screw (6.2744.070) and an adapter (6.2744.080) to fasten the other end of the PTFE capillary to Port 1 of the Dosino.
- 4 Connect the FEP tubing (6.1805.120) from the bottle with the regeneration solution to Port 2 of the Dosino.

3.10.2.4 Connecting the rinsing solution

Various possibilities exist for rinsing the Metrohm Suppressor Module:

- Rinsing solution via STREAM (recommended)
Use the eluent from the conductivity detector as rinsing solution.
- Rinsing solution via Dosino
Prepare the rinsing solution in a separate bottle and convey it with a Dosino.

The rinsing solution is connected to the *rinsing solution* capillary.

Connecting the rinsing solution inlet with STREAM

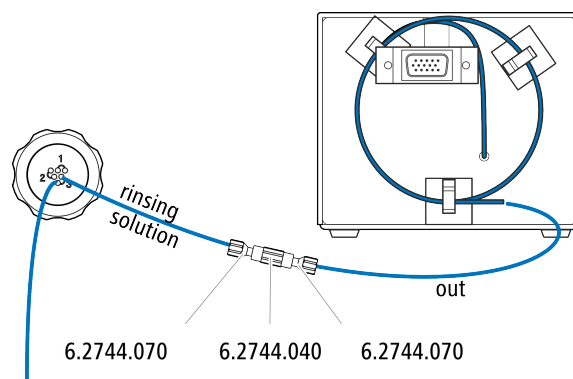

- 1 Connect the detector outlet capillary of the conductivity detector and the capillary labeled *rinsing solution* to each other using a coupling (6.2744.040) and two pressure screws (6.2744.070).



NOTE

The detector outlet capillary must not be shortened.

Connecting the rinsing solution inlet to the Dosino

The *rinsing solution* capillary can be connected to the Dosino to which the *regenerant* capillary is already connected.

For this step, you need the following accessories: (not contained in its entirety in the standard accessories):

- 3 short pressure screws (6.2744.070)

- Inline filter (6.2821.120)
- PTFE capillary (6.1803.030)
- Adapter M6/UNF (6.2744.080)
- FEP tubing M6 / 100 cm (6.1805.120)
- Adapter Dosino Port 4, M6 inner (6.1808.280)

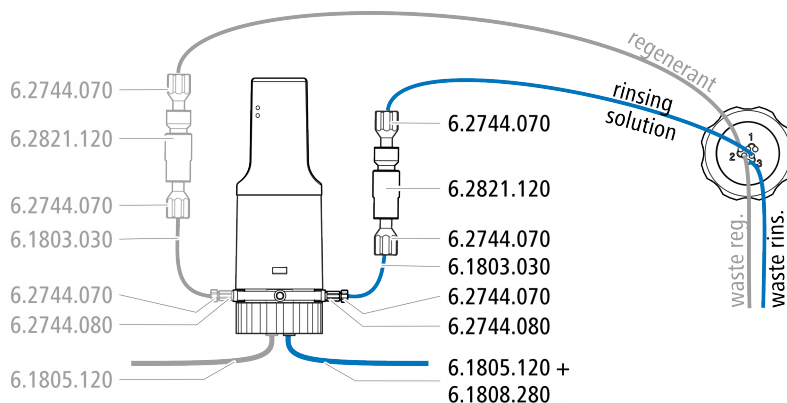

- 1** Fasten the capillary labeled *rinsing solution* to the outlet of an inline filter (6.2821.120) using a pressure screw (6.2744.070).
- 2** Use a pressure screw (6.2744.070) to fasten a piece of the PTFE capillary (6.1803.030) to the inlet of the inline filter.
- 3** Use a pressure screw (6.2744.070) and an adapter (6.2744.080) to fasten the other end of the PTFE capillary to Port 3 of the Dosino.
- 4** Connect the FEP tubing (6.1805.120) from the bottle with the rinsing solution with the adapter (6.1808.280) to Port 4 of the Dosino.

3.11 Installing the conductivity detector

The 930 Compact IC Flex provides enough space for one detector and additional accessories in the detector chamber. The detector is available as separate device and is supplied with a separate manual.

Placing the detector in the instrument

Follow the instructions in the chapter *Inserting the detector* in the manual for the detector.

Connecting the detector to the eluent path



NOTE

The separation column is not inserted into the instrument until it is being started up for the first time. Until then, the detector inlet capillary has to be connected to the *out* capillary of the Metrohm Suppressor Module (MSM) using a coupling (6.2744.040).

Accessories

For this step, you need the following accessories:

- Coupling (6.2744.040)
- 2 × pressure screw (6.2744.070)

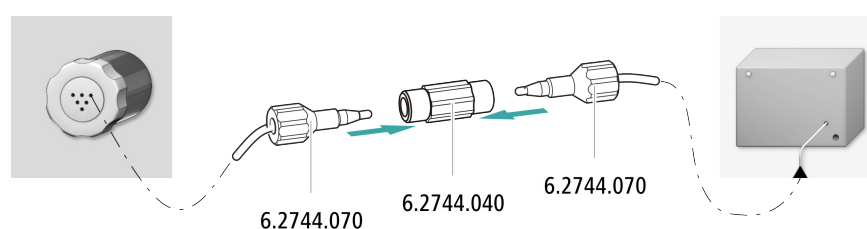

- 1 Connect the *out* capillary of the Metrohm Suppressor Module (MSM) and the detector inlet capillary to each other using a coupling (6.2744.040) and two short pressure screws (6.2744.070).

3.12 Installing the amperometric detector

The 930 Compact IC Flex provides enough space for one detector and additional accessories in the detector chamber. The detector is available as separate device and is supplied with a separate manual.

Placing the detector in the instrument

Follow the instructions in the chapter *Inserting the detector* in the manual for the detector.



3.13 Connecting the instrument to a computer



NOTE

If the instrument is connected to the computer, then it must be switched off.

Accessories

For this step, you need the following accessories:

- USB connection cable (6.2151.020) from the accessory kit: Vario/Flex Basic (6.5000.000)

Connecting the USB cable

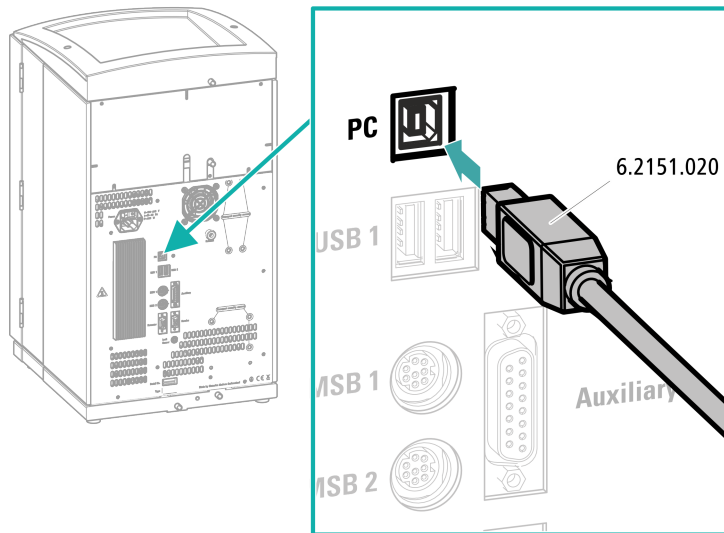

- 1 Insert the USB cable into the computer connection socket on the rear of the instrument.
- 2 Insert the other end into a USB port on the computer.

3.14 Connecting the instrument to the power grid



WARNING

Electric shock from electrical potential

Risk of injury by touching live components or through moisture on live parts.

- Never open the housing of the instrument while the power cord is still connected.
- Protect live parts (e.g. power supply unit, power cord, connection sockets) against moisture.
- Unplug the power plug immediately if you suspect that moisture has gotten inside the instrument.
- Only personnel who have been issued Metrohm qualifications may perform service and repair work on electrical and electronic parts.

Connecting the power cord

Accessories

Power cord with the following specifications:

- Length: max. 2 m
- Number of cores: 3, with protective conductor
- Instrument plug: IEC 60320 type C13
- Conductor cross-section 3x min. 1.0 mm² / 18 AWG
- Power plug:
 - according to customer requirement (6.2122.XX0)
 - min. 10 A



NOTE

Do not use a not permitted power cord!

1 Plugging in the power cord

- Plug the power cord into the instrument's power socket.
- Connect the power cord to the power grid.

3 Starting equilibration

- Start the equilibration in MagIC Net: **Workplace ► Run ► Equilibration ► Start HW.**

4 Deaerating the high-pressure pump

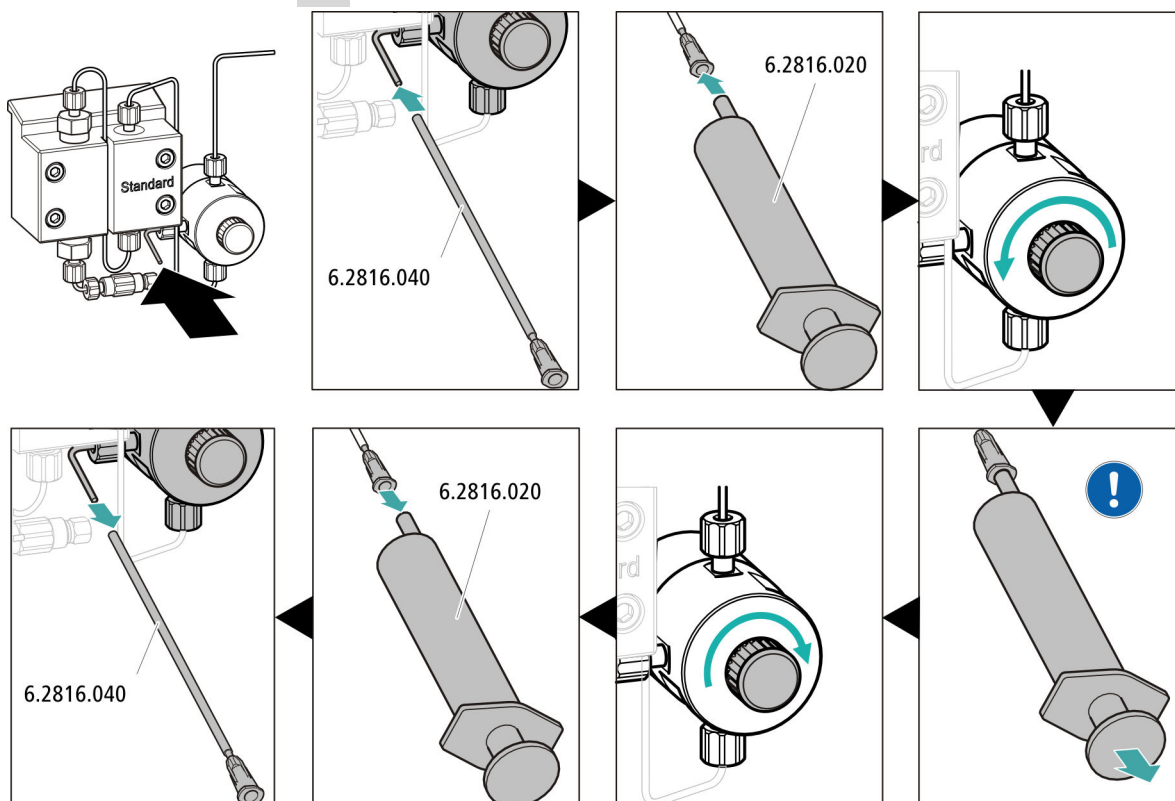

- Push the end of the purge needle (6.2816.040) over the end of the purge capillary on the purge valve.
- Insert the syringe (6.2816.020) in the Luer connector of the purge needle.
- Open the purge valve using the rotary knob (approx. $\frac{1}{2}$ turn).
- Switch on the high-pressure pump in MagIC Net.
- Use the syringe to aspirate eluent until there are no more air bubbles in the eluent aspiration tubing.
- Switch off the high-pressure pump in MagIC Net.
- Seal the purge valve using the rotary knob.
- Remove the syringe from the purge needle.
- Pull the purge needle out of the purge capillary.

5 Rinsing the instrument without columns

- Rinse the instrument (without columns) with eluent for 10 minutes.

Connecting the guard column

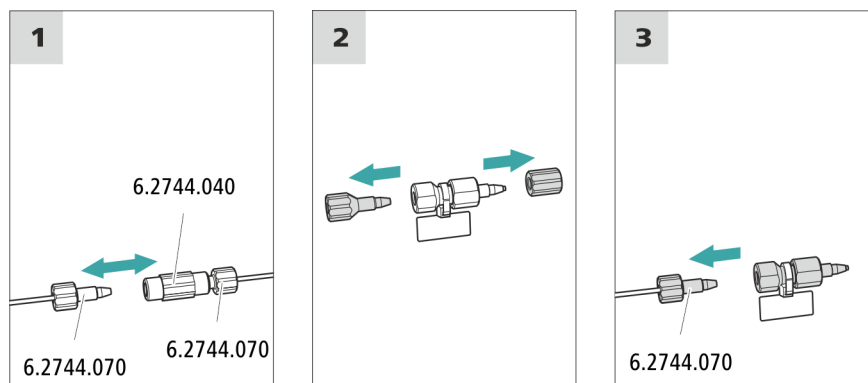

1 Removing the coupling

Remove the coupling (6.2744.040) installed between the column inlet capillary and the column outlet capillary for the initial start-up.

2 Preparing the guard column

- Remove the stoppers or the stopper and the sealing cap from the guard column.

3 Connecting the guard column



CAUTION

When inserting the guard column, ensure that it is inserted correctly based on the marked flow direction (if specified).

- Fasten the inlet of the guard column to the column inlet capillary using a short pressure screw (6.2744.070).
- If the guard column is connected to the separation column using a connection capillary, fasten this connection capillary to the guard column outlet with a pressure screw.

Rinsing the guard column

1 Rinsing the guard column

- Place a beaker under the guard column's outlet.



- Start manual control in MagIC Net and select the high-pressure pump: **Manual ► Manual control ► Pump**
 - **Flow: in accordance with column leaflet**
 - **On**
- Rinse the guard column with eluent for approx. 5 minutes.
- Stop the high-pressure pump in the manual control in MagIC Net again: **Off**.

3.17 Connecting the separation column

The smart separation column (iColumn) is the heart of ion chromatographic analysis. It separates the different components according to their interactions with the column. Metrohm separation columns are equipped with a chip where their technical specifications and history (start-up, operating hours, injections etc) are stored.



NOTE

Information regarding which separation column is suitable for your application can be found in the **Metrohm Column Program**, the product information for the separation column or it can be obtained through your representative.

You can find product information for your separation column at <http://www.metrohm.com> in the Ion Chromatography product area.

A test chromatogram and a leaflet accompanies every column. Detailed information on special IC applications can be found in the corresponding "**Application Bulletins**" or "**Application Notes**". You can find these online at <http://www.metrohm.com> in the Applications area or request them from your responsible Metrohm representative free of charge.



CAUTION

New separation columns are filled with a solution and sealed with stoppers on both sides. Before inserting the column, ensure that this solution can be mixed with the eluent being used (follow the information provided by the manufacturer).



NOTE

Connect the separation column only after the initial start-up of the instrument. Until that point, insert a coupling (6.2744.040) instead of the guard column and separation column.

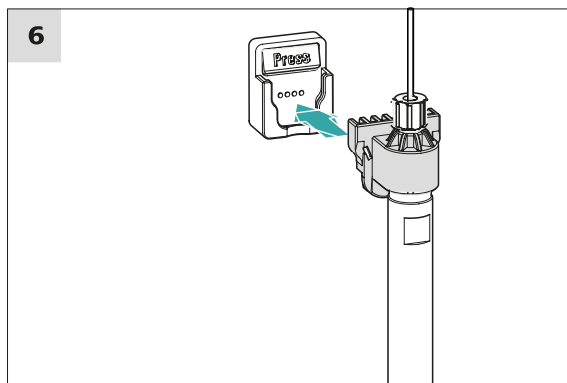
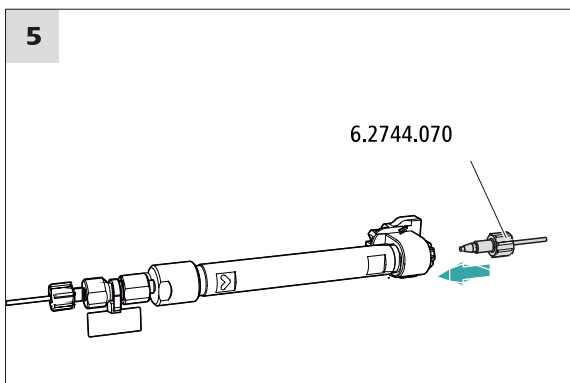
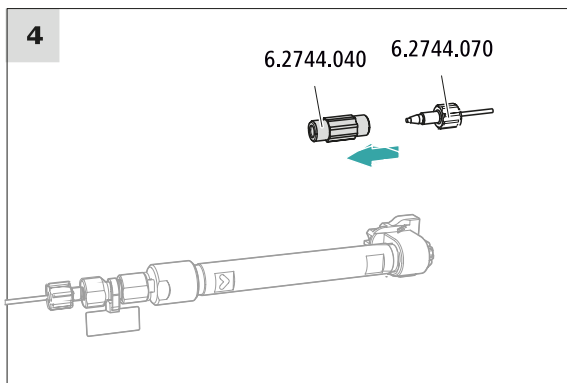
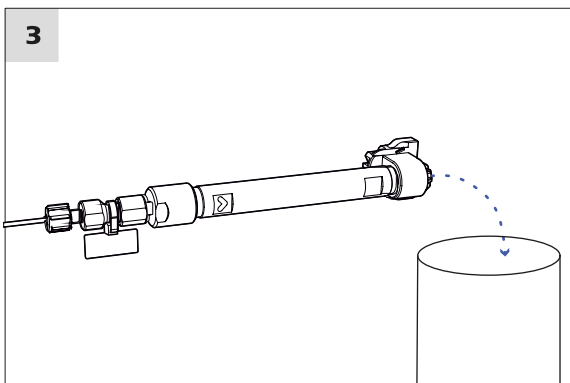
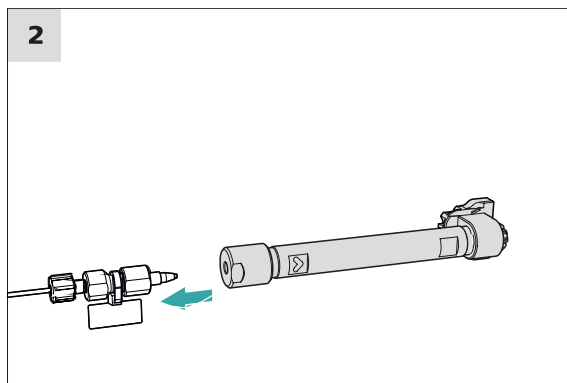
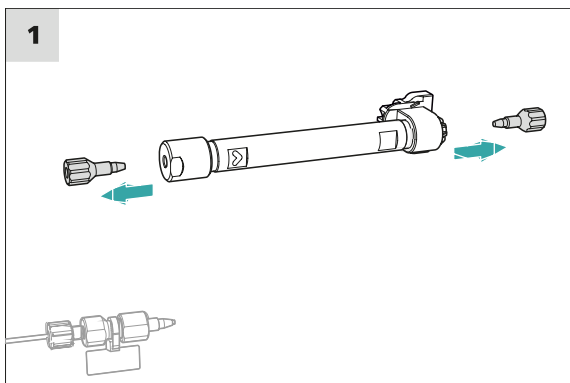

Connecting the separation column

1 Removing the stoppers

- Remove the stoppers from the separation column.

3.18 Conditioning

In the following cases, the system must be conditioned with eluent until a stable baseline has been reached:

- After installation
- After each time the instrument is switched on
- After each eluent change



NOTE

The conditioning time can lengthen considerably if the composition of the eluent is modified.

Conditioning the system

1 Preparing the software



CAUTION

Ensure that the configured flow rate is not higher than the flow rate permitted for the corresponding column (refer to the column leaflet and chip data record).

- Start the **MagIC Net** computer program.
- Open the **Equilibration** tab in MagIC Net: **Workplace ► Run ► Equilibration**.
- Select (or create) a suitable method.
Also see: *MagIC Net Tutorial* and online help.

2 Preparing the instrument

- Ensure that the column is inserted correctly in accordance with the flow direction marked on the sticker (arrow has to point in the direction of flow).
- Ensure that the eluent aspiration tubing is immersed in the eluent and that there is enough eluent in the eluent bottle.

3 Starting equilibration

- Start the equilibration in MagIC Net: **Workplace ► Run ► Equilibration ► Start HW**.



- Visually inspect whether all capillaries and their connections from the high-pressure pump to the detector are leak-tight. If eluent is leaking out anywhere, tighten the corresponding pressure screw further, or loosen the pressure screw, check the end of the capillary and shorten it using the capillary cutter if necessary and retighten the pressure screw.

4 Conditioning the system

Continue rinsing the system with eluent until the desired stability level for the baseline has been attained .

The instrument is now ready for measuring samples.

4 Operation

The 930 Compact IC Flex ChS is operated solely using the MagIC Net software. You can find information on operating the software in the tutorial for MagIC Net or in the online help.

5.1.4 Shutting down and recommissioning

If the instrument is no longer used for a prolonged period, remove the guard column and the separation column. Rinse the IC system until it is salt-free with a mixture of methanol and ultrapure water (1:4). This prevents eluent salts from crystallizing and then causing damage. This prevents eluent salts from crystallizing and then causing consequential damage.

Rinsing the IC system to be free of salts

- 1** In the software, stop the hardware and wait until the pressure in the high-pressure pump has been released.
- 2** Remove the guard column and the separation column from the eluent path. Connect the connection capillaries directly with each other using a coupling (6.2744.040).
- 3** Rinse the IC system for 15 minutes with methanol/ultrapure water mixture (1:4).
- 4** Optional: Only if the IC system is equipped with a suppressor.
In the software, switch the Metrohm Suppressor Module (MSM) twice during the rinsing process at five-minute intervals in each case (STEP command).
- 5** Optional: Only if the IC system is equipped with a suppressor and a peristaltic pump.
Rinse the pump tubings used for the peristaltic pump with water for 15 minutes at level 1. Finish by releasing the contact pressure at the peristaltic pump.

Putting the IC system back into operation

- 1** Check that a coupling (6.2744.040) is installed in place of the guard column and the separation column.
- 2** Rinse the IC system with freshly prepared eluent for 15 minutes.
- 3** Remove the coupling and install the guard column and the separation column (see Chapter 3.16, page 42 and Chapter 3.17, page 44).

5.4.1 Manufacturing eluent

Chemicals used for manufacturing eluents must have a purity grade of at least "p.a.". They may be diluted only by using ultrapure water (resistance > 18.2 MΩ*cm). (These specifications apply generally for all reagents used in ion chromatography.)

Newly manufactured eluents always need to be microfiltered (0.45 µm filter).

The composition of the eluent plays a critical role in chromatographic analysis:

Concentration	An increase in the concentration generally leads to shorter retention times and faster separation, but also to a higher background conductivity signal.
pH	pH changes lead to shifts in dissociation equilibria and thus to changes in retention times.
Organic solvents	Adding organic solvents (e.g. methanol, acetone or acetonitrile) to a watery eluent generally speeds up lipophilic ions.

5.4.2 Changing the eluent

Ensure that no precipitates can form when changing the eluent. Immediately successive solutions must be miscible. If the system must be rinsed with organic solvents, several solvents with rising or falling lipophilicity must be used.



NOTE

To change the eluent, remove the guard column and the separation column. Connect the capillaries using a coupling (6.2744.040) and two pressure screws (6.2744.070).

5.5 Notes on operating the high-pressure pump



CAUTION

The pump head is filled ex works with methanol/ultrapure water. Ensure that the eluent used is miscible with this solvent.

Keep the following recommendations in mind in order to protect the high-pressure pump from damage as much as possible during operation:

- To protect the high-pressure pump from **foreign particles**, we recommend filtering the eluent through a filter with a pore size of 0.45 µm and aspirating it via an aspiration filter (6.2821.090).
- Ensure that no precipitates can form when changing the eluent. Salt crystals between the piston and seal cause abrasive particles that can find their way into the eluent. These particles lead to contaminated valves, an increase in pressure and, in extreme cases, scratched pistons and thus to leakages in the high-pressure pump.
Immediately successive solutions must always be miscible. If the system must be rinsed with organic solvents, use several solvents with rising or falling lipophilicity.
- In order to protect the pump seals, ensure that the pump is never operated dry. Therefore ensure that the eluent supply is correctly connected and that there is enough eluent in the eluent bottle each time before turning on the pump.

5.6 Servicing the high-pressure pump



NOTE

You can find a video sequence for this task in the *Multimedia Guide IC Maintenance* or on the Internet at <http://ic-help.metrohm.com/>.

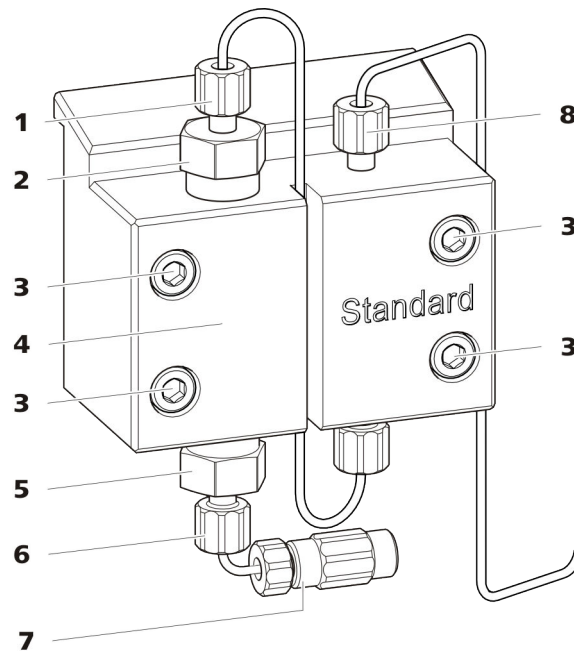

Figure 14 High-pressure pump – Parts

1 Pressure screw, short (6.2744.070) Fastened to the outlet valve holder.	2 Outlet valve holder
3 Fastening screw	4 Pump head
5 Inlet valve holder	6 Pressure screw, short (6.2744.070) Fastened to the inlet valve holder.
7 Eluent aspiration tubing connector Consists of a coupling with a pressure screw.	8 Pressure screw, short (6.2744.070) Fastened to the pump output.

Maintenance interval The following parts of the high-pressure pump must be serviced at least once per year:

- Inlet valve (6.2824.170)
- Outlet valve (6.2824.160)
- Piston seal (6.2741.020)
- Zirconium oxide piston (6.2824.070)

Maintenance tasks can also be carried out if the following problems occur:

- Unstable baseline (pulsations, flow fluctuations)



CAUTION

Maintenance work on the high-pressure pump may not be carried out unless the **instrument is switched off**.



Recommended procedure

We recommend the following procedure for the maintenance of the pump head:

1. Service the inlet valve and the outlet valve.
2. Remove the pump head.
3. Service both pistons, one after the other.
 - a. Remove piston.
 - b. Dismantle the piston.
 - c. Replace the piston seal.
 - d. Replace the zirconium oxide piston.
 - e. Assemble the piston.
 - f. Insert the piston.
4. Reinstall the pump head.

You can find brief video sequences on the following maintenance steps on the Internet at <http://ic-help.metrohm.com/>.

Servicing the outlet valve and inlet valve

Accessories

For this step, you need the following accessories:

You can find these parts in the accessory kit: *Vario/Flex Basic* (6.5000.000).

- Adjustable wrench (6.2621.000)

Cleaning the outlet valve

Spare parts

If the outlet valve cannot be cleaned, you will need a new outlet valve (6.2824.160) for this step.

1 Removing the outlet valve

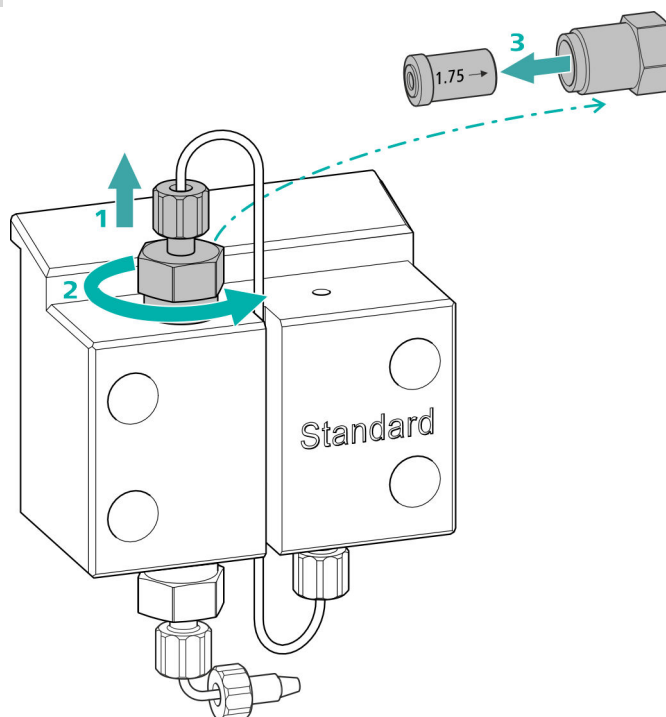

- Unscrew the connection capillary to the auxiliary piston from the outlet valve holder (14-2) (1).
- Start by loosening the outlet valve holder with the adjustable wrench and then unscrew it by hand (2) and remove it.
- Remove the outlet valve from the outlet valve holder (3).

2 Cleaning the outlet valve

- Start by rinsing the outlet valve in the direction of eluent flow using a wash bottle filled with ultrapure water, RBS™ solution or acetone. (The direction of eluent flow is marked on the valve by an arrow.)
The rinsing solution must come out at the valve outlet.
If no more solution comes out, then the valve is blocked.
- Rinse the outlet valve in the direction opposite the eluent flow using a wash bottle filled with ultrapure water, RBS™ solution or acetone.
The rinsing solution may only come out at the valve outlet.

The outlet valve must be replaced if it is still clogged after cleaning.



3 Reinserting the outlet valve into the pump head

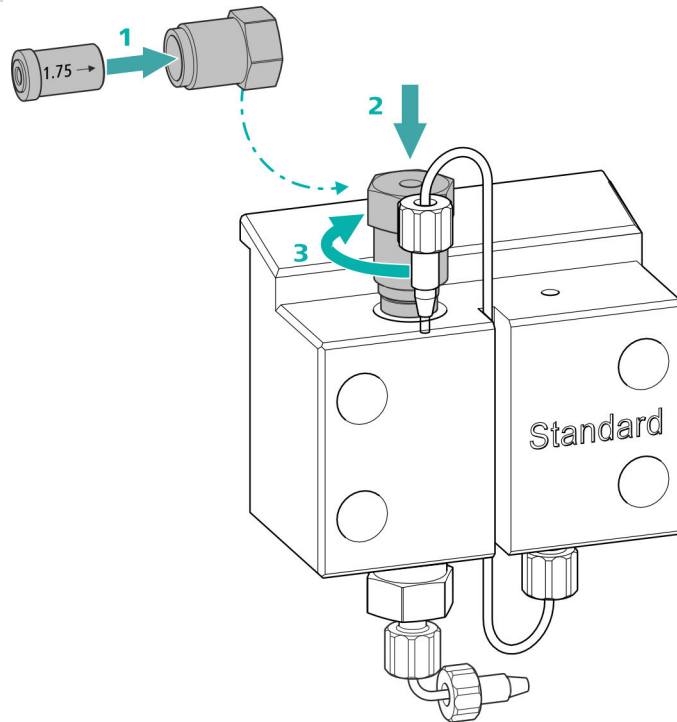

- Insert the outlet valve into the outlet valve holder (the seal must be visible) (1).
- Screw the outlet valve holder up into the pump head (2) and tighten it firmly by hand and then retighten it one additional $\frac{1}{4}$ turn using the adjustable wrench (3).
- Tighten the connection capillary to the auxiliary piston back onto the outlet valve holder.

Cleaning the inlet valve

Spare parts

If the inlet valve cannot be cleaned, you will need a new inlet valve (6.2824.170) for this step.

1 Removing the inlet valve

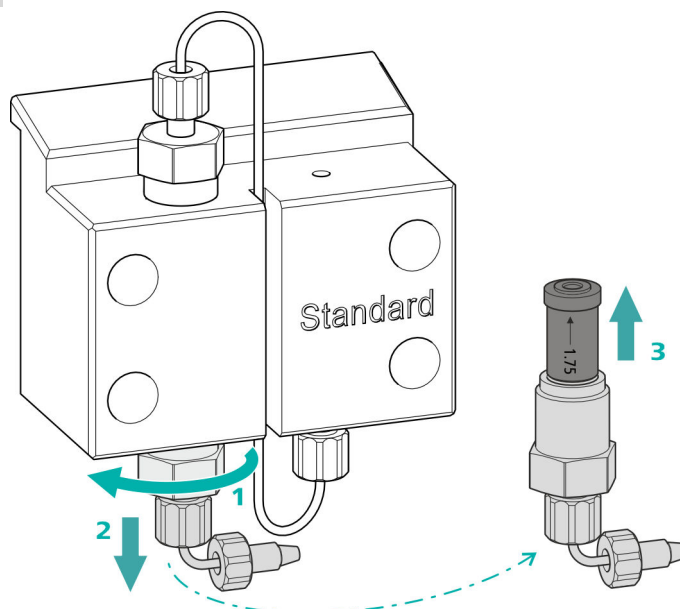

- Unscrew the connection capillary to the connection of the eluent aspiration tubing (14-7).
- Start by loosening the inlet valve holder with the adjustable wrench (1) and then unscrew it by hand (2) and remove it.
- Remove the inlet valve from the inlet valve holder (3).

2 Cleaning the inlet valve

- Start by rinsing the inlet valve in the direction of eluent flow using a wash bottle filled with ultrapure water, RBS™ solution or acetone. (The direction of eluent flow is marked on the valve by an arrow.)

The rinsing solution must come out at the valve outlet.

If no more solution comes out, then the valve is blocked.

- Rinse the inlet valve in the direction opposite the eluent flow using a wash bottle filled with ultrapure water, RBS™ solution or acetone.

The rinsing solution may only come out at the valve outlet.

The inlet valve must be replaced if it is still clogged after cleaning.

3 Reinserting the inlet valve into the pump head

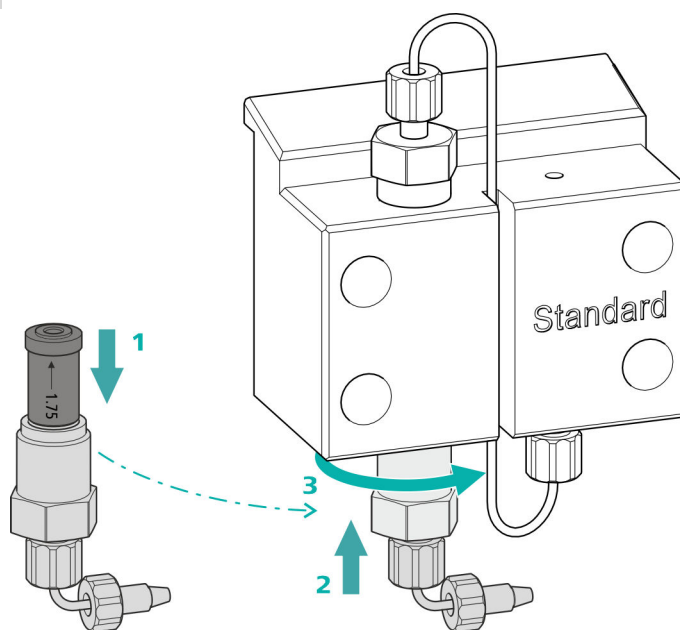

- Insert the inlet valve into the inlet valve holder (the seal must be visible) (1).
- Screw the inlet valve holder up into the pump head (2) and tighten it firmly by hand and then retighten it one additional $\frac{1}{4}$ turn using the adjustable wrench (3).
- Refasten the connection capillary to the connection of the eluent aspiration tubing (14-7).

Removing the pump head

Accessories

For this step, you need the following accessories:

You can find these parts in the accessory kit: *Vario/Flex Basic* (6.5000.000).

- 4 mm hex key (6.2621.030)

Removing the pump head

Prerequisites:

- Is the high-pressure pump switched off?
- Has the pressure been released?
- Is the instrument switched off?

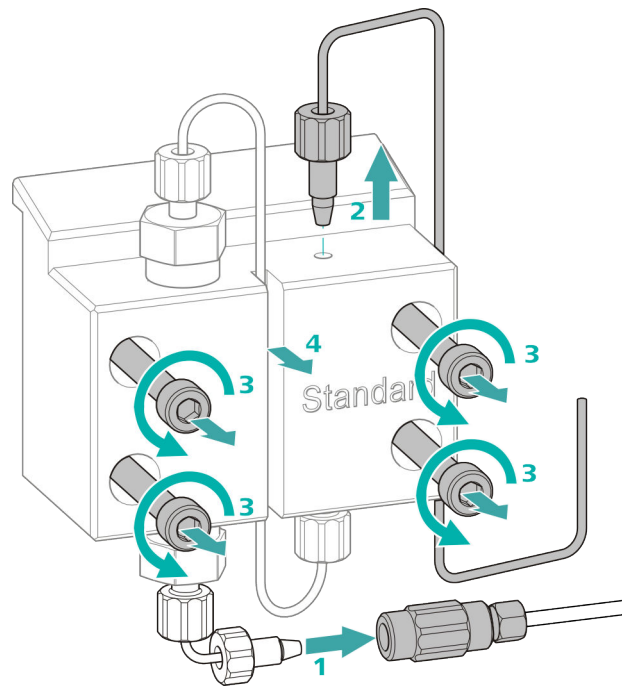

- 1** Release the coupling from the pressure screw and seal it with a stopper.
- 2** Unscrew and remove the pressure screw on the pump head's outlet (14-8).
- 3** Loosen and remove the four fastening screws (14-3) using the hex key.
- 4** Remove the pump head (14-4).

Servicing the piston

Carry out the following work on both pistons in turn.

Servicing a piston consists of the following tasks:

1. Replace the piston seal.
2. Clean or replace the zirconium oxide piston.
3. Reinstall the piston.

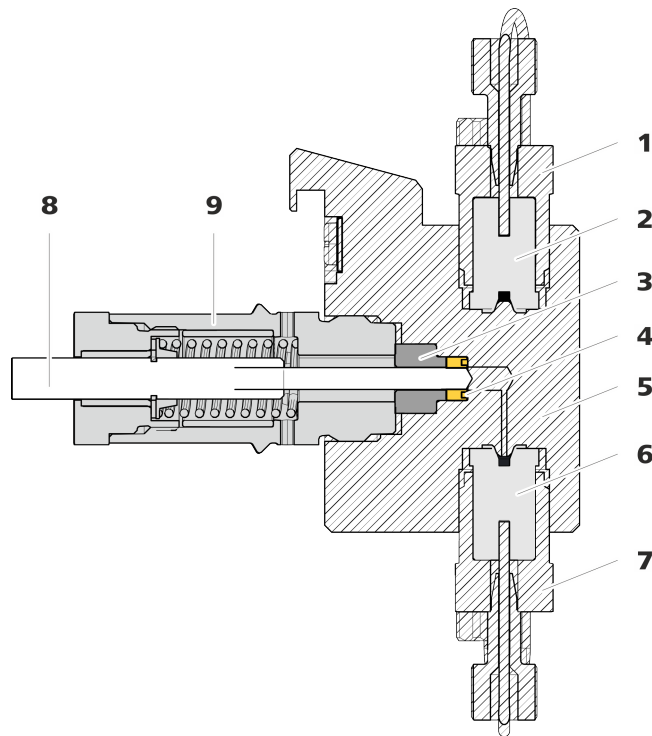

Figure 15 High-pressure pump – Cross-section

1	Outlet valve holder	2	Outlet valve (6.2824.160)
3	Backup ring	4	Piston seal (6.2741.020)
5	Pump head	6	Inlet valve (6.2824.170)
7	Inlet valve holder	8	Zirconium oxide piston (6.2824.070)
9	Piston cartridge		

Accessories

For this step, you need the following accessories:

You can find these parts in the accessory kit: *Vario/Flex Basic* (6.5000.000).

- Adjustable wrench (6.2621.000)
- Tool for piston seals (6.2617.010) consisting of a tip (16-1) for removing the old piston seal and a sleeve (16-2) for inserting the new piston seal.

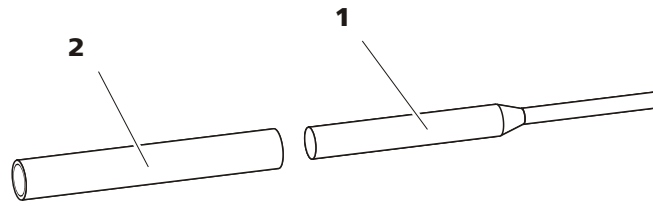

Figure 16 Tool for piston seal (6.2617.010)

1 Tip

2 Sleeve

Spare part

For this step, you need a new piston seal (6.2741.020).

Replacing the piston seal

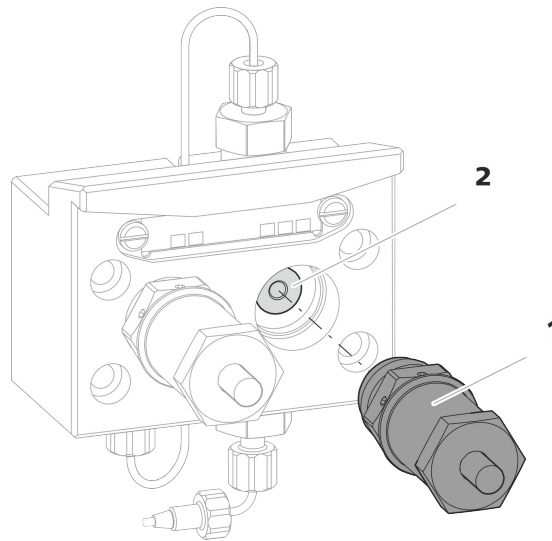

Figure 17 Removing the piston cartridge from the pump head

1 Piston cartridge

2 Backup ring

1 Removing the piston cartridge

Loosen the piston cartridge (17-**1**) using the adjustable wrench and then unscrew it from the pump head by hand. Set it aside.

2 Removing the backup ring

Shake the backup ring (17-**2**) out of the piston opening. Set it aside.



3 Removing the old piston seal



CAUTION

Screwing the (6.2617.010) special tool for the piston seal into the piston seal destroys this completely!



CAUTION

Avoid touching the sealing surface in the pump head with the tool!

Only screw the tip (16-1) of the tool for the piston seal far enough into the piston seal that the seal can be pulled out.

4 Inserting the new piston seal into the tool

Insert the new piston seal into the recess of the sleeve (18-1) of the tool for piston seal. The sealing spring must be visible from the outside.

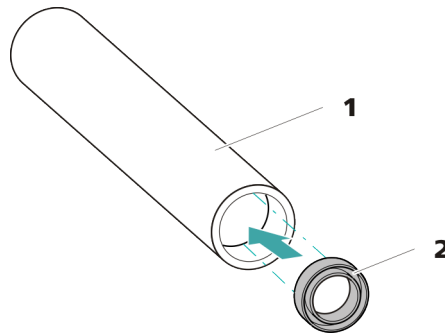

Figure 18 Inserting the piston seal into the tool

1 Tool for piston seal (6.2617.010)
Sleeve for inserting the new piston seal.

2 Piston seal (6.2741.020)

5 Inserting the new piston seal into the pump head

Guide the sleeve (16-2) of the tool for the piston seal with inserted piston seal into the pump head. Press the seal into the pump head recess using the wide end of the tip (16-1) of the tool.

Cleaning or replacing the zirconium oxide piston

Prerequisites:

- The pump head has been removed (see "Removing the pump head", page 60).
- The piston cartridge is removed (see "Replacing the piston seal", page 63).

For this task, you need the following accessories:

- Zirconium oxide piston (6.2824.070)
- Adjustable wrench (6.2621.000) from the accessory kit: *Vario/Flex Basic* (6.5000.000).

1 Breaking down the piston cartridge



CAUTION

Inside the piston cartridge there is a taut spring that can launch out of the piston cartridge if the tension is released suddenly.

When opening the piston cartridge, counteract the pressure from the spring and carefully unscrew the cartridge.

- Loosen the piston cartridge's screw with an adjustable wrench and carefully unscrew the screw by hand while counteracting the pressure from the taut spring.
- Remove the zirconium oxide piston and place it on a paper towel.
- Remove the spring retainer, the spring and the inner plastic sleeve from the piston cartridge and lay them next to the piston.
- Place the backup ring you put aside with the remaining parts.

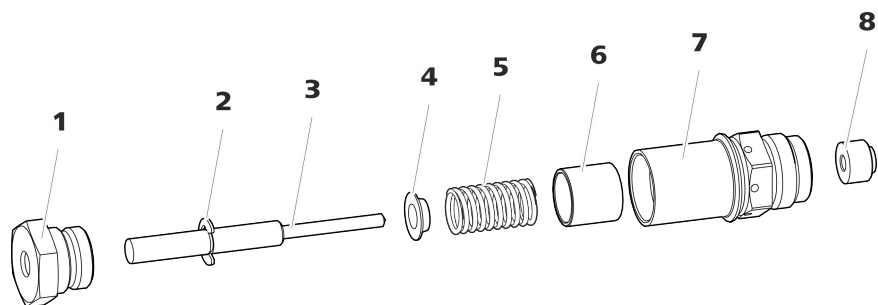

Figure 19 Parts of the piston cartridge

1	Piston cartridge screw	2	Retaining washer
3	Zirconium oxide piston (6.2824.070)	4	Spring retainer
5	Spring (6.2824.060)	6	Inner plastic sleeve Protects from metallic abrasion.
7	Piston cartridge	8	Backup ring



2 Cleaning the parts of the piston cartridge

- If the zirconium oxide piston has become contaminated due to abrasion or deposits, then clean it using a fine abrasive cleaning powder, rinse it using ultrapure water until it is free of particles and dry it.

The zirconium oxide piston must be replaced if it is heavily contaminated or scratched.

- Rinse the other parts of the piston with ultrapure water and dry with a lint-free cloth.

3 Replacing the zirconium oxide piston

- Remove the retaining washer (19-2) from the old piston. If the retaining washer sits too tightly, use a pointed object to loosen the retaining washer.
- Assemble the retaining washer at the same point on the new piston.

4 Putting the piston cartridge together

- Insert the inner plastic sleeve, the spring and the spring retainer into the piston cartridge.
- Slide the zirconium oxide piston carefully into the piston cartridge until its tip emerges from the small opening of the piston cartridge.
- Attach the screw and tighten it by hand.

Mounting the piston

1 Reinserting the backup ring

Clean the backup ring (15-3) with ultrapure water and reinsert it.

2 Reinserting the piston cartridge

Screw the assembled piston cartridge back into the pump head and tighten, first by hand, then also using an adjustable wrench by approx. 15°.

Clean the second piston cartridge in the same way.

Mounting the pump head

For this step, you need the following accessories:

You can find these parts in the accessory kit: *Vario/Flex Basic* (6.5000.000).

Accessories

- 4 mm hex key (6.2621.030)

Mounting the pump head



NOTE

The pump head cannot be mounted the wrong way, as it has fastening bolts with different bore hole depths, i.e., one fastening bolt is longer than all others. The bore hole with the greatest depth must therefore be aligned with the longest bolt.

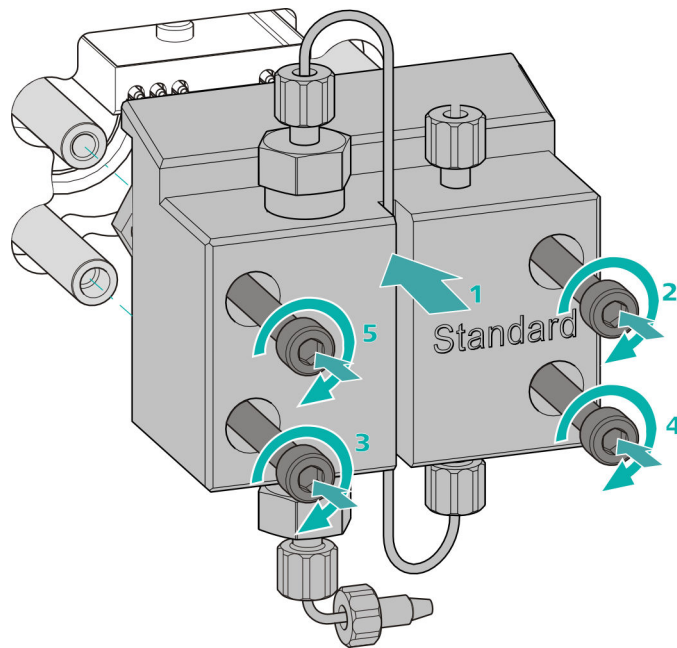

- 1
 - Push the pump head onto the four fastening bolts (1).
 - Tighten the four fastening screws using the hex key (6.2621.030) alternating crosswise.

Connecting the entry and exit for the high-pressure pump

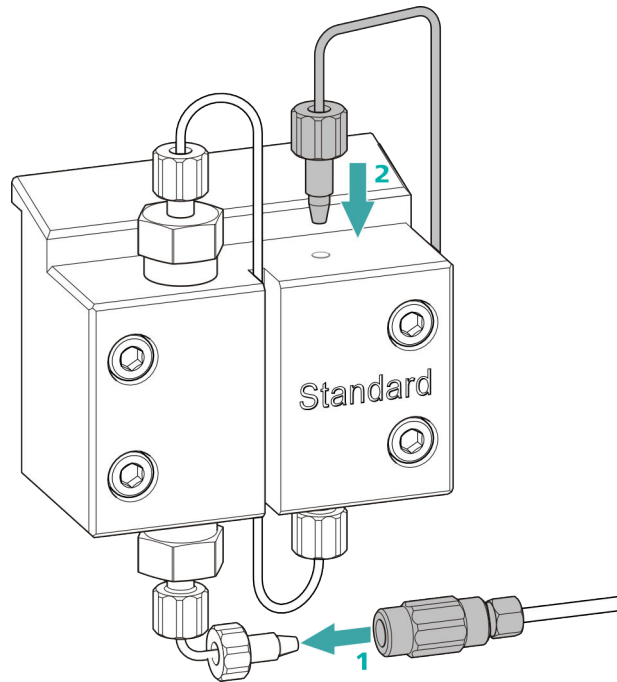

- 1
 - Remove the stopper from the coupling. Tighten the coupling to the pressure screw located on the pump head inlet capillary (1).
 - Reconnect the pump head outlet capillary to the pump head outlet (2).

5.7 Servicing the inline filter



NOTE

You can find a video sequence for this task in the *Multimedia Guide IC Maintenance* or on the Internet at <http://ic-help.metrohm.com/>.

Maintenance interval

The filter must be replaced at least every 3 months; it may need to be replaced more frequently, depending on the application.

Accessories

For this task, you need the following accessories:

- Two adjustable wrenches (6.2621.000) from the accessory kit: Vario/Flex Basic (6.5000.000)
- Tweezers
- A new filter from the packaging (6.2821.130)

Removing the filter

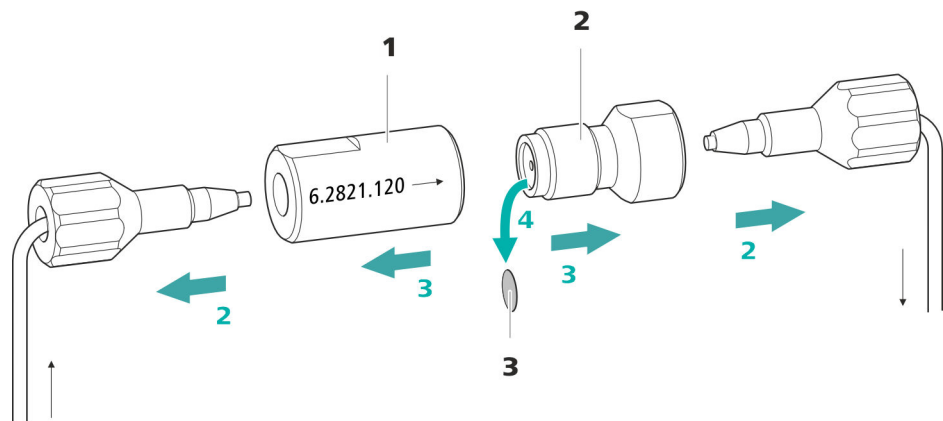

Figure 20 Inline filter – Removing the filter

1 Filter housing

Inline filter housing. Part of the accessories (6.2821.120).

2 Filter screw

Screw for the inline filter. Part of the accessories (6.2821.120).

3 Filter (6.2821.130)

Pack contains 10 pieces.

1 Shutting off the flow

Switch off the high-pressure pump in the software.

2 Removing the inline filter

Unscrew both pressure screws from the inline filter.

3 Unscrewing the filter screw

Use two adjustable wrenches (6.2621.000) to loosen the filter screw (20-2) from the filter housing (20-1) and unscrew it by hand.

4 Removing the filter

Remove the old filter (20-3) using tweezers.

Inserting a new filter

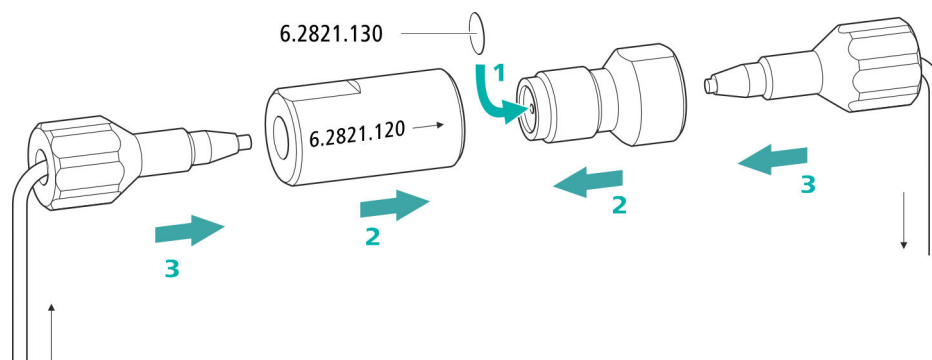

1 Inserting a new filter

- Use tweezers to carefully place a new filter into the filter screw (20-2) so that it is flat and press it firmly into place with the rear of the tweezers.

2 Installing the filter screw

- Screw the filter screw (20-2) back into the filter housing (20-1) and tighten by hand. Then use two adjustable wrenches (6.2621.000) to tighten it slightly.

3 Remounting the inline filter

- Screw pressure screws back onto the inline filter. Take care to ensure that the flow direction matches that inscribed on the inline filter.

4 Rinsing the inline filter

- Dismantle the guard column (if present) and the separation column and replace with a coupling (6.2744.040).
- Rinse the instrument with eluent.
- Reinsert the columns after 10 minutes.

5.8 Servicing the pulsation absorber



CAUTION

The pulsation absorber is maintenance-free and must not be opened.

5.9 Injection valve

Maintenance on the injection valve is best performed by specialist personnel from Metrohm during annual service.

5.10 Metrohm Suppressor Module (MSM)

5.10.1 Notes for operating the Metrohm Suppressor Module (MSM)



NOTE

The suppressor units must never be regenerated in the same flow direction the eluent is pumped. Therefore, always mount the inlet and outlet capillaries according to the diagram outlined in *Chapter Connecting the Metrohm Suppressor Module (MSM)*, page 32.

The Metrohm Suppressor Module (MSM) consists of three suppressor units, which, in rotation, are (1.) used for suppression, (2.) regenerated with regeneration solution and (3.) rinsed with ultrapure water or with suppressed eluent. In order to record each new chromatogram under comparable conditions, work is normally performed with a freshly regenerated and rinsed suppressor unit.



CAUTION

The Metrohm Suppressor Module (MSM) must never be switched over if liquid is not flowing through it, since otherwise it may become jammed. If the Metrohm Suppressor Module (MSM) is in a dry state, it must be rinsed for at least five minutes before it may be switched over.



CAUTION

The Metrohm Suppressor Module (MSM) must be regenerated (see chapter 5.10.3.2, page 73), cleaned (see chapter 5.10.3.4, page 75) or replaced (see chapter 5.10.3.5, page 78) if the capacity of the Metrohm Suppressor Module (MSM) is reduced or if the backpressure is high.

5.10.2 Taking care of the suppressor housing



CAUTION

The transparent suppressor housing can become fogged.

The suppressor housing is made of PMMA (poly(methyl methacrylate)). It can become scratched and foggy if cleaned improperly. This can make viewing the rotor difficult or impossible.

- Do **not use any scouring agents** for cleaning.
- Do **not use any solvents** for cleaning.

5.10.3 Servicing the Metrohm Suppressor Module (MSM)

5.10.3.1 Parts of the Metrohm Suppressor Module (MSM)

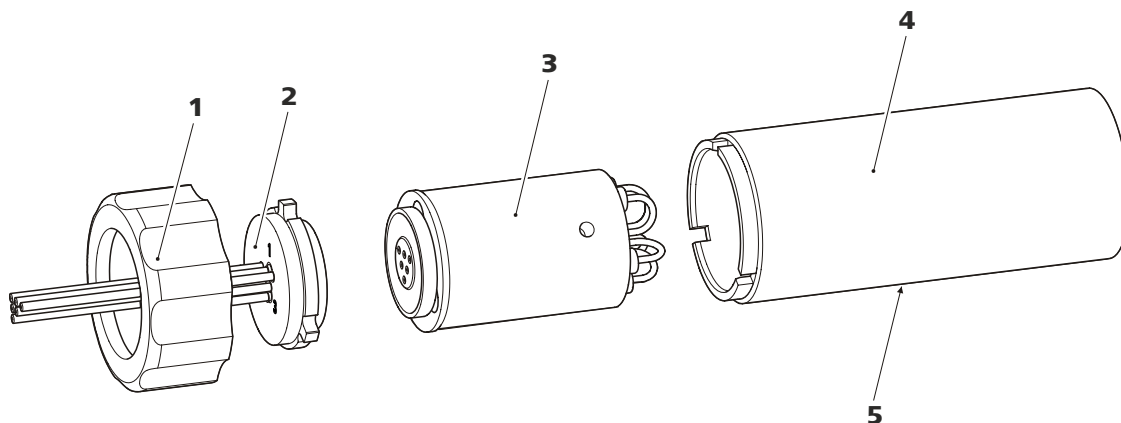

Figure 21 Parts of the Metrohm Suppressor Module (MSM)

1	Union nut	2	Connecting piece
3	Rotor	4	Housing
5	Slot in the housing		

5.10.3.2 Regenerating the anion suppression rotor

If the anion suppressor units are loaded with certain heavy metals (such as iron) or organic contamination for long periods, then the standard regeneration solution may no longer be able to completely remove them. This constantly reduces the capacity of the suppressor units, which results in reduced phosphate sensitivity in mild cases and a large increase in the baseline in severe cases.

If such capacity problems occur at one or more positions, all anion suppressor units must be regenerated with one of the following solutions:

Regeneration solutions

- **Contamination with heavy metals or elevated backpressure:**
1 mol/L H₂SO₄ + 0.1 mol/L oxalic acid
- **Contamination with organic cationic complexing agents:**
0.1 mol/L H₂SO₄ / 0.1 mol/L oxalic acid / acetone 5%
- **Heavy contamination with organic substances:**
0.2 mol/L H₂SO₄ / acetone ≥ 20%
- **Contamination by certain environmental samples**
1 mol/L H₃PO₄



NOTE

If phosphoric acid has been used once as regeneration solution in an IC system, you will have to continue using phosphoric acid for regeneration. Regenerating it with sulfuric acid again can lead to problems in the baseline.



CAUTION

Pump tubing made of PVC must not be used for solutions containing organic solvents.

We recommend using the high-pressure pump for regeneration.

Regenerating the anion suppressor rotor

1 Disconnecting the Metrohm Suppressor Module (MSM) from the IC system

- Disconnect the capillaries of the MSM labeled **regenerant** and **rinsing solution** from the IC system.

5.10.3.3 Regenerating the cation suppression rotor

If the cation suppressor units are exposed to certain contaminations for prolonged periods, then these contaminations can no longer be removed completely with the standard regeneration solution. The performance of the suppressor units declines continuously, as indicated by a rise of the baseline or asymmetrical peaks.

If such problems occur at one or more positions, then treat all of the cation suppressor units as follows:

Regenerating the cation suppressor

1 Stopping the regeneration solution

Stop the regeneration solution feed.

2 Regenerating the first cation suppressor unit

Rinse the system with eluent until the suppressor unit is completely exhausted (indicated by a significant increase in conductivity). This can take up to 240 minutes under standard conditions.

3 Regenerating the second cation suppressor unit

In the software, use the **Step** command to switch to the next suppressor unit. Repeat step 2.

4 Regenerating the third cation suppressor unit

In the software, use the **Step** command to switch to the next suppressor unit. Repeat step 2.

5 Restoring the regeneration solution

As soon as all three suppressor units are completely exhausted, restore the regeneration solution feed.

6 Equilibrating the system

Equilibrate the system as usual (*see chapter "Conditioning" in the manual for the ion chromatograph*).

5.10.3.4 Cleaning the Metrohm Suppressor Module (MSM)

In the following cases, it may be necessary to clean the Metrohm Suppressor Module (MSM):

- Increased backpressure at the MSM's connection tubing.

For an overview of the rotors, see figure , page 28

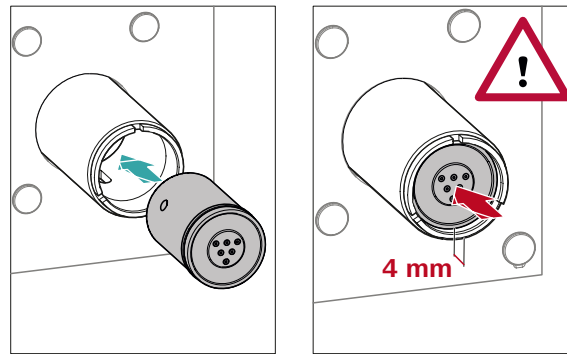

- Insert the rotor (21-3) into the housing (21-4) in such a way that the tubing connections on the rear of the rotor fit into the corresponding recesses inside the housing and one of the three holes of the rotor is visible from below in the slot of the housing (21-5).



NOTE

The rotor's sealing surface is located approx. 4 mm deep inside the suppressor drive if the rotor is inserted correctly.

If this is not the case, then the rotor must be moved into the correct position using careful turning. If the rotor cannot be turned or removed, it can be moved into the correct position from below by means of a pointed object (e.g. a screwdriver).

6 Cleaning the connecting piece

- Clean the sealing surface of the connecting piece (21-2) with ethanol using a lint-free cloth.

7 Inserting the connecting piece

See also Chapter 3.10.1, page 29

- Insert the connecting piece (21-2) into the housing in such a way that connector 1 is on top and the three pins of the connecting piece fit into the corresponding recesses on the housing.
- Reattach the union nut (21-1) and tighten by hand (do not use a tool).

8 Connecting and conditioning the Metrohm Suppressor Module (MSM)

- Reconnect the MSM to the IC system.
- Before switching the MSM over for the first time, rinse each of the three suppressor units with solution for five minutes.

**NOTE**

The adapter (6.2842.020) (see "Inserting small rotors", page 31) is required in order to insert a small rotor into the suppressor drive.

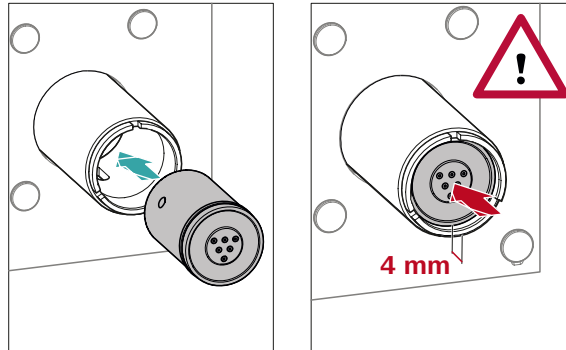

- Insert the new rotor (21-3) into the housing (21-4) in such a way that the tubing connections on the rear of the rotor fit into the corresponding recesses inside the housing and one of the three holes of the rotor is visible from below in the slot of the housing (21-5).

**NOTE**

The rotor's sealing surface is located approx. 4 mm deep inside the suppressor drive if the rotor is inserted correctly.

If this is not the case, then the rotor must be moved into the correct position using careful turning. If the rotor cannot be turned or removed, it can be moved into the correct position from below by means of a pointed object (e.g. a screwdriver).

5 Cleaning the new connecting piece

- Clean the sealing surface of the new connecting piece (21-2) with ethanol using a lint-free cloth.

6 Inserting the new connecting piece

See also Chapter 3.10.1, Page 29

- Insert the connecting piece (21-2) into the housing in such a way that connector 1 is on top and the three pins of the connecting piece fit into the corresponding recesses on the housing.
- Reattach the union nut (21-1) and tighten by hand (do not use a tool).



7 Connecting and conditioning the Metrohm Suppressor Module (MSM)

- Reconnect all capillaries of the MSM to the IC system.
- Before switching the MSM over for the first time, rinse the three suppressor units with solution for five minutes.

5.11 Servicing the detector

Follow the maintenance instructions in the the detector's manual.

5.12 Rinsing the sample path

Before a new sample is measured, the sample path must be rinsed with it long enough to prevent the measuring result from being falsified by the previous sample (sample carry-over).

The time required to rinse the sample path with the new sample is called the rinsing time. The rinsing time depends on the transfer time.

The transfer time corresponds to the time the sample needs to flow from the sample vessel to the end of the sample loop. The transfer time depends on the following factors:

- The pump capacity of the peristaltic pump or of the Dosino that is used for the sample transfer.
- The total capillary volume
- The volume of the gas removed from the sample by the sample degasser (if a sample degasser is present and connected)

The transfer time can be determined as follows:

Determining the transfer time

1 Emptying the sample path

Pump air through the sample path (pump tubing, tubing connections, capillary in the degasser, sample loop) for several minutes until all liquid is displaced by the air.

2 Unscrewing the sample loop

Unscrew the end of the sample loop.

3 Aspirating the sample and measuring the time

Aspirate a sample typical for the later application and use a stop-watch to measure the time the sample needs to go from the sample vessel to the end of the sample loop.

The time upon stopping the watch is the "transfer time".

4 Tightening the sample loop again

Tighten the sample loop again.

If the sample is injected automatically, the rinsing time must be at least three times the **transfer time**.

Checking the rinsing time

You can determine if the applied rinsing time is sufficient by measuring the sample carry-over directly. Proceed as follows to do this:

1 Preparing two samples

- **Sample A:** A typical sample for the application.
- **Sample B:** Ultrapure water.

2 Determining "Sample A"

Allow "Sample A" to run through the sample path for the duration of the rinsing time; inject and then measure it.

3 Determining "Sample B"

Allow "Sample B" to run through the sample path for the duration of the rinsing time; inject and then measure it.

4 Calculating the sample carry-over

The sample carry-over corresponds to the ratio of the peak areas of the measurement from Sample B to the measurement from Sample A. The smaller this ratio, the smaller the amount of sample carry-over. This ratio can be changed by varying the rinsing time. This can be used to determine the required rinsing time for the application.



NOTE

Regeneration is intended as a last resort. It should not be carried out regularly.

Problem	Cause	Remedy
	<i>Guard column – Blocked.</i>	Replace the guard column (<i>see chapter 3.16, page 42</i>).
	<i>Separation column – Blocked.</i>	<ul style="list-style-type: none"> ▪ Regenerate the separation column (<i>see chapter 5.13.4, page 82</i>). ▪ Replace the separation column (<i>see "Connecting the separation column", page 45</i>). <p>Note: Samples should always be microfiltered .</p>
	<i>Injection valve – blocked.</i>	Have the valve cleaned (by a Metrohm service engineer).
The retention times in the chromatogram have changed unexpectedly.	<i>Eluent - Incorrect concentration</i>	Create eluent with correct concentration.
	<i>Separation column – Diminished separating efficiency.</i>	<ul style="list-style-type: none"> ▪ Regenerate the separation column (<i>see chapter 5.13.4, page 82</i>). ▪ Replace the separation column (<i>see "Connecting the separation column", page 45</i>).
	<i>The eluent contains gas bubbles.</i>	<ul style="list-style-type: none"> ▪ Purge the high-pressure pump (<i>see figure , page 41</i>).
	<i>High-pressure pump – Defective.</i>	Request Metrohm Service.
Peak areas are lower than expected.	<i>Sample – There is a leak in the sample path.</i>	Find and fix the leak in the sample path.
	<i>Sample – The sample path is blocked.</i>	Find and eliminate the blockage in the sample path.
	<i>Sample – The sample loop is not (completely) filled.</i>	Adjust the transfer time for the sample (<i>see "Determining the transfer time", page 80</i>).
	<i>Sample – There are gas bubbles in the sample.</i>	Use the sample degasser .
Data of the separation column cannot be read.	<i>Column chip dirty.</i>	Clean the contact surfaces of the column chip with ethanol.
	<i>Column chip is defective.</i>	<ol style="list-style-type: none"> 1. Save column configuration in MagIC Net. 2. Notify Metrohm Service.

Problem	Cause	Remedy
Extreme spread of the peaks in the chromatogram. Splitting (dual peaks)	<i>Capillary connections – Dead volume in the system.</i>	Check the capillary connections (<i>see chapter 3.2, page 13</i>) (use PEEK capillaries with an inner diameter of 0.25 mm between the injection valve and detector).
	<i>Guard column – Diminished efficiency.</i>	Replace the guard column (<i>see chapter 3.16, page 42</i>).
	<i>Separation column – Dead volume at the column head.</i>	<ul style="list-style-type: none"> ▪ Install the separation column in the opposite flow direction (if the leaflet says this is permissible) and rinse into a beaker. ▪ Replace the separation column (<i>see "Connecting the separation column", page 45</i>).
Precision problems - the measured values are highly scattered.	<i>Injection valve – Sample loop.</i>	Check the installation of the sample loop (<i>see "Optional: Exchanging the sample loop", page 27</i>).
	<i>Sample – There are gas bubbles in the sample.</i>	Use the sample degasser .
	<i>Sample – The rinsing volume is too small.</i>	Increase the rinsing time (<i>see chapter 5.12, page 80</i>).
	<i>Injection valve – Defective.</i>	Request Metrohm Service.



7 Technical specifications

7.1 Reference conditions

The technical specifications listed in this chapter refer to the following reference conditions:

<i>Ambient temperature</i>	+25 °C (±3 °C)
<i>Instrument status</i>	> 40 minutes in operation

7.2 Ambient conditions

Operation

<i>Nominal function range</i>	+5 to +45 °C at max. 80% relative humidity, non-condensing
-------------------------------	---

<i>Storage</i>	+5 to +45 °C at max. 80% relative humidity, non-condensing
----------------	---

<i>Altitude / Pressure range</i>	max. 3,000 m.a.s.l. sea level / min. 700 mbar
----------------------------------	---

<i>Overvoltage category</i>	II
-----------------------------	----

<i>Pollution degree</i>	2
-------------------------	---

7.3 Housing

Dimensions

Width 302 mm

Height 562 mm

Depth 368 mm

<i>Base tray, housing and bottle holder material</i>	Polyurethane hard foam (PUR) with flame retardation for fire class UL 94 V-0, CFC-free, coated
--	--

<i>IP degree of protection</i>	IP 20
--------------------------------	-------

Controls

Indicators LED for standby indicator

On/off switch On the rear of the instrument

7.4 Weight

2.930.1200 22.32 kg (without accessories)

7.5 Leak sensor

Type Electronic, no calibration necessary

7.6 High-pressure pump

Type

- Serial dual-piston pump
- Intelligent pump head recognition
- Chemically inert
- Metal-free pump heads
- Materials in contact with the eluent: PEEK, ZrO₂, PTFE/PE
- Self-optimizing flow and pressure

Flow rate

Adjustable flow range 0.001 - 20 mL/min
 0.01 - 5 mL/min with standard PEEK pump head

Flow increment 1 µL/min

Reproducibility of the eluent flow < 0.1% deviation

Pressure range

Pump 0 - 50.0 MPa (0 - 500 bar)

Pump head 0 - 35.0 MPa (0 - 350 bar) (applies for the standard PEEK pump head)

Residual pulsation < 1%

Safety shutdown

Function Automatic shutdown upon reaching the pressure limits

Maximum pressure limit

- Adjustable from 0.1 - 50 MPa (1 - 500 bar)
- The pump is automatically shut down at the first piston stroke above the maximum limit value

Minimum pressure limit

- Adjustable from 0 - 49 MPa (0 - 490 bar)
- The shutdown mechanism is inactive at 0 MPa
- The shutdown mechanism becomes active two minutes after system start
- The pump is automatically shut down after three piston strokes below the minimum pressure limit



7.7 Injection valve

<i>Actuator switching time</i>	typ. 100 ms
<i>Maximum operating pressure</i>	35 MPa (350 bar)
<i>Material</i>	PEEK

7.8 Metrohm Suppressor Module (MSM)

<i>Resistance to solvents</i>	No restriction
<i>Switching time</i>	typ. 100 ms

7.9 Detector

You can find the technical specifications for the detector in the manual for the detector.

7.10 Energy supply

<i>Nominal voltage range</i>	100–240 V (\pm 10%)
<i>Nominal frequency range</i>	50–60 Hz (\pm 3%)
<i>Power consumption</i>	<ul style="list-style-type: none"> ▪ 65 W for typical analysis application ▪ 25 W standby (conductivity detector to 40 °C)
<i>Power supply unit</i>	<ul style="list-style-type: none"> ▪ up to 300 W maximum, electronically monitored ▪ internal fuse 3.15 A

7.11 Interfaces

USB

Input 1 USB upstream, type B (labeled **PC** for connecting to a computer)

Output 2 USB downstream, type A (labeled **USB 1** and **USB 2**)

MSB 2 MSB 8-pin Mini DIN (female) (labeled **MSB 1** and **MSB 2** for Dosino, stirrer, remote lines, etc.)

Detector 1 15-pin high-density D-sub (female) (labeled **Detector**)

Column recognition for an intelligent column

Leak sensor 1 jack plug (labeled **Leak Sensor**)

Further connections

Auxiliary 1 15-pin DSUB (female)

Service 1 15-pin DSUB (female)

8 Accessories

Up-to-date information on the scope of delivery and on optional accessories for your instrument can be found on the Internet. You can download this information using the article number as follows:

Downloading the accessories list

- 1 Type <https://www.metrohm.com/> into your Internet browser.
- 2 Under **Find products, accessories, and applications by**, enter the article number (e.g. **2.930.1200**).
The search result is displayed.
- 3 Under **Products**, click on **More information**.
Detailed information regarding the product is shown on various tabs.
- 4 On the **Included parts** tab, click on **Download the PDF**.
The PDF file with the accessories data will be created.



NOTE

When you receive your new instrument, we recommend downloading the accessories list from the Internet, printing it out and keeping it together with the manual for reference purposes.

Index

A

Ambient conditions 88
 Anion suppressor
 Regeneration 73
 Aspiration filter (6.2821.090) 52
 Aspiration tubing for eluent 20

B

Baseline
 Condition 48
 Unstable 55

C

Capillaries
 Installation 13
 Carry-over 80
 Cation suppressor
 Regeneration 75
 Clean
 Inlet valve 59
 Outlet valve 57
 Suppressor 75
 Column
 see "Separation column" 44
 Column recognition 91
 Computer connection 38
 Conditioning 48
 Connect
 Connect to power grid 39
 To computer 38
 Connections
 Installation 13
 Contamination
 High-pressure pump 54
 Valves for the high-pressure
 pump 55
 Contamination of suppressor
 Heavy metals 73
 Organic 73
 Crystallization
 High-pressure pump 54

D

Detector
 Interface 91
 Dimensions 88
 Door 52
 Drainage tubing
 Installation 17

E

Electrostatic charge 4
 Eluent
 Aspirate 20
 Change 53
 Manufacturing 53
 Eluent bottle
 Installation 19
 Energy supply 90
 Equilibration 41, 47

F

Feed-through
 For cables 10
 For capillaries 10
 Filter
 Aspiration filter 52
 see "Inline filter" 25
 Flow fluctuations 55
 Flow increment 89
 Flow range 89
 Flow rate 89
 Frequency 90

G

Guard column
 Installation 42
 Rinse 43

H

Heavy metals
 Contamination of suppressor
 73
 High-pressure pump
 Maintenance 54
 Protection 17, 54
 Technical specifications 89
 Housing 88
 Humidity 88

I

IC column
 see "Separation column" 44
 Injection valve 2
 Installation 26
 Maintenance 71
 Technical specifications 90
 Inline filter 25
 Installation
 Connections 13

Drainage tubing 17
 Eluent bottle 19
 Guard column 42
 Injection valve 26
 Leak sensor 19
 Pulsation absorber 25
 Separation column 44
 Suppressor 28

Interface

 Further connections 91
 Leak sensor 91
 MSB 91
 USB 91
 Interfaces 91

L

Leak sensor
 Installation 19
 Interface 91
 Technical specifications 89
 Leak-tightness 41
 Leakage 55
 Leaky piston seals 55
 Loop
 See also "Sample loop" 26

M

Maintenance
 High-pressure pump 54
 Injection valve 71
 Suppressor 71
 Material 88
 MSB 91

O

Operation 88
 Suppressor 71
 Organic contamination
 Suppressor 73
 Overvoltage category 88

P

Piston of the high-pressure pump
 55
 Piston seal 55
 Power connection 39
 Power consumption 90
 Power supply unit 90
 Precipitate 54
 Pressure increase 54

Index

- Pressure limit 89
Pressure range 89
Protection
 Inline filter 25
Pulsation 55
Pulsation absorber
 Installation 25
- R**
- Reference conditions 88
Regeneration 50
 Anion suppressor 73
 Cation suppressor 75
Rinse
 Guard column 43
 Sample path 80
 Separation column 46
Rinsing time 81
- S**
- Safety instructions 3
Safety shutdown 89
Sample
 Carry-over 80
 Sample loop 26
 Transfer time 80
Sample loop 26
- Sample path
 Rinse 80
Sea level 88
Separation column
 Installation 44
 Protection 2, 25, 82
 Regeneration 82
 Rinse 46
 Separating efficiency 82
 Storage 82
Service 3, 50
Shutting down 51
Storage 88
Supply voltage 4
Suppression rotor
 see Suppressor 73, 75
Suppressor
 Clean 75
 Install rotor 28
 Installation 28
 Maintenance 71
 Operation 71
 Replacing parts 78
 Switching 71
 Technical specifications 90
- Suppressor drive
 see "Suppressor" 28
- T**
- Technical specifications
 Detector 91
 High-pressure pump 89
 Injection valve 90
 Interfaces 91
 Leak sensor 89
 Reference conditions 88
 Suppressor 90
Temperature 88
Transfer time 80
Transport locking screws 16
Tubings
 Installation 13
- U**
- USB 91
- V**
- Vacuum pump
 Protection 17
Valve
 See also "Injection valve" 26
Voltage 90