

IC Professional Detector



896 Professional Detector – Amperometry

Manual
8.896.8005EN



Metrohm AG
CH-9100 Herisau
Switzerland
Phone +41 71 353 85 85
Fax +41 71 353 89 01
info@metrohm.com
www.metrohm.com

IC Professional Detector

896 Professional Detector – Amperometry

2.896.0020

Manual

Teachware
Metrohm AG
CH-9100 Herisau
teachware@metrohm.com

This documentation is protected by copyright. All rights reserved.

Although all the information given in this documentation has been checked with great care, errors cannot be entirely excluded. Should you notice any mistakes please send us your comments using the address given above.

Documentation in additional languages can be found on
<http://documents.metrohm.com>.

Table of contents

1	Introduction	1
1.1	Instrument description	1
1.2	Intended use	2
1.3	Safety instructions	2
1.3.1	General notes on safety	2
1.3.2	Electrical safety	2
1.3.3	Tubing and capillary connections	3
1.3.4	Flammable solvents and chemicals	4
1.3.5	Recycling and disposal	4
1.4	About the documentation	4
1.4.1	Content and scope	4
1.4.2	Symbols and conventions	5
2	Overview of the instrument	6
2.1	Front	6
2.2	Rear	8
3	Installation	9
3.1	Setting up the instrument	9
3.1.1	Packaging	9
3.1.2	Checks	9
3.1.3	Location	9
3.1.4	Proposed setup	9
3.2	Mounting base tray and bottle holder (optional)	10
3.2.1	Removing / mounting the base tray	10
3.2.2	Removing / mounting the bottle holder	12
3.3	Amperometric detector	15
3.4	Connecting the instrument	15
3.4.1	Connecting the instrument to the PC	15
3.4.2	Connecting the instrument to power supply	15
4	Start-up	17
4.1	Instrument test with dummy cell	17
4.2	Testing the leak sensor	19
4.3	Testing the preheating capillary	19
4.4	Testing the detector output capillary	20
4.5	Testing the measuring cell	22
4.6	Deaerating the measuring cell	24



4.7	Connecting the electrode connection cables	25
4.8	Attaching the front lid	27
5	Operation and maintenance	28
5.1	General notes	28
5.1.1	Care	28
5.1.2	Maintenance by Metrohm Service	28
5.1.3	Operation	28
5.1.4	Shutting down	29
5.2	Amperometric detector	29
5.2.1	Maintenance	29
5.2.2	Preheating capillary maintenance	29
5.3	Quality Management and validation with Metrohm	30
6	Troubleshooting	31
6.1	Problems with the hardware	31
6.2	Problems with the baseline	31
6.3	General remarks regarding sensitivity fluctuations	34
6.4	Problems with sensitivity	34
6.5	Problems with the pressure	35
6.6	Problems with the measuring signal	35
6.7	Problems with the chromatogram	36
6.8	Other problems	37
6.9	Systematic error diagnostics	38
7	Technical specifications	40
7.1	Reference conditions	40
7.2	Amperometric detector	40
7.3	Power connection	41
7.4	Leak sensor	42
7.5	Ambient conditions	42
7.6	Housing	42
7.7	Interfaces	43
7.8	Safety specifications	43
7.9	Electromagnetic compatibility (EMC)	44
8	Warranty (Guarantee)	45



9 Accessories	47
9.1 Scope of delivery	47
9.2 Optional accessories	49
Index	54



Table of figures

Figure 1	Front	6
Figure 2	Front - open	7
Figure 3	Rear	8

1 Introduction

1.1 Instrument description

The **896 Professional Detector – Amperometry** is an intelligent Stand-Alone Detector equipped with an amperometric detector.

As a stand-alone detector, it can for example be combined with instruments of the 850 Professional IC family for which all available detector connectors have already been assigned to conductivity detectors (AnCat systems or other multi-channel systems) and be used for the determination of electroactive substances in the mobile phase.

It is also possible to implement applications with the 896 Professional Detector – Amperometry that require amperometric detection, even with the instruments of the Compact IC family (881 and 882) and with the 883 Basic IC plus, which possess only one detector connector which would normally be occupied by a conductivity detector.

The 896 Professional Detector – Amperometry is a stand-alone detector that combines the advantages of the 850 IC Amperometric Detector with the combination opportunities of the 850 Professional IC instruments. It is directly controlled by the MagIC Net™ software.

872 Extension Modules, 891 Analog Out and 800 Dosinos, Remote Boxes, etc. can all be operated through the 896 Professional Detector – Amperometry. This opens up the flexibility of Metrohm IC systems considerably.

The instrument is comprised of the following modules:

Amperometric detector

With the 896 Professional Detector – Amperometry, electroactive substances can be determined in the mobile phase of an IC system. Amperometric methods are used for the determination, which combine an outstanding sensitivity with a high degree of selectivity. The installed potentiostat generates the voltages for the direct current amperometry (DC), for the pulse amperometry (PAD) and the flexible integrated pulse amperometry (flex-PAD) as well as for the recording of cyclovoltammograms. The installed preheating capillary ensures a constant eluent temperature on the cell.



1.2 Intended use

The 896 Professional Detector – Amperometry is used for the amperometric detection in an IC system. Its function is to make precise determinations of electroactive substances in the mobile phase of an IC or general liquid chromatography system.

The present instrument is used for working with chemicals and flammable samples. Usage of the 896 Professional Detector – Amperometry therefore requires the user to have basic knowledge and experience in the handling of toxic and caustic substances. Knowledge with respect to the application of the fire prevention measures prescribed for laboratories is also mandatory.

1.3 Safety instructions

1.3.1 General notes on safety



Warning

This instrument may only be operated in accordance with the specifications in this documentation.

This instrument has left the factory in a flawless state in terms of technical safety. To maintain this state and ensure non-hazardous operation of the instrument, the following instructions must be observed carefully.

1.3.2 Electrical safety

The electrical safety when working with the instrument is ensured as part of the international standard IEC 61010.



Warning

Only personnel qualified by Metrohm are authorized to carry out service work on electronic components.



Warning

Never open the housing of the instrument. The instrument could be damaged by this. There is also a risk of serious injury if live components are touched.

There are no parts inside the housing which can be serviced or replaced by the user.

Mains voltage



Warning

An incorrect mains voltage can damage the instrument.

Only operate this instrument with a mains voltage specified for it (see rear panel of the instrument).

Protection against electrostatic charges



Warning

Electronic components are sensitive to electrostatic charges and can be destroyed by discharges.

Do not fail to pull the mains cable out of the mains connection socket before you set up or disconnect electrical plug connections at the rear of the instrument.

1.3.3 Tubing and capillary connections



Caution

Leaks in tubing and capillary connections are a safety risk. Tighten all connections well by hand. Avoid applying excessive force to tubing connections. Damaged tubing ends lead to leakage. Appropriate tools can be used to loosen connections.

Check the connections regularly for leakage. If the instrument is used mainly in unattended operation, then weekly inspections are mandatory.



1.3.4 Flammable solvents and chemicals



Warning

All relevant safety measures are to be observed when working with flammable solvents and chemicals.

- Set up the instrument in a well-ventilated location (e.g. fume cupboard).
- Keep all sources of flame far from the workplace.
- Clean up spilled liquids and solids immediately.
- Follow the safety instructions of the chemical manufacturer.

1.3.5 Recycling and disposal

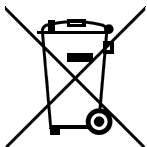

This product is covered by European Directive 2002/96/EC, WEEE – Waste from Electrical and Electronic Equipment.

The correct disposal of your old equipment will help to prevent negative effects on the environment and public health.

More details about the disposal of your old equipment can be obtained from your local authorities, from waste disposal companies or from your local dealer.

1.4 About the documentation



Caution

Please read through this documentation carefully before putting the instrument into operation. The documentation contains information and warnings which the user must follow in order to ensure safe operation of the instrument.

1.4.1 Content and scope







This document describes the **896 Professional Detector – Amperometry**, its assembly and connection to the IC instrument, as well as the installation, operation and maintenance of the individual components. Technical specifications, troubleshooting and information concerning scope of delivery and optional accessories make up the rest of the manual.

You will find additional information on the installation and maintenance of the IC instrument and the Sample Processor in the respective manuals.

Additional information for configuration and operation with MagIC Net™ can be found in the "Tutorial for MagIC Net™" or in the MagIC Net™ online help.

1.4.2 Symbols and conventions

The following symbols and formatting may appear in this documentation:

(5-12)	Cross-reference to figure legend
	The first number refers to the figure number, the second to the instrument part in the figure.
1	Instruction step
	Carry out these steps in the sequence shown.
Method	Dialog text, parameter in the software
File ▶ New	Menu or menu item
[Next]	Button or key
	Warning
	This symbol draws attention to a possible life hazard or risk of injury.
	Warning
	This symbol draws attention to a possible hazard due to electrical current.
	Warning
	This symbol draws attention to a possible hazard due to heat or hot instrument parts.
	Warning
	This symbol draws attention to a possible biological hazard.
	Caution
	This symbol draws attention to a possible damage of instruments or instrument parts.
	Note
	This symbol marks additional information and tips.



2 Overview of the instrument

2.1 Front

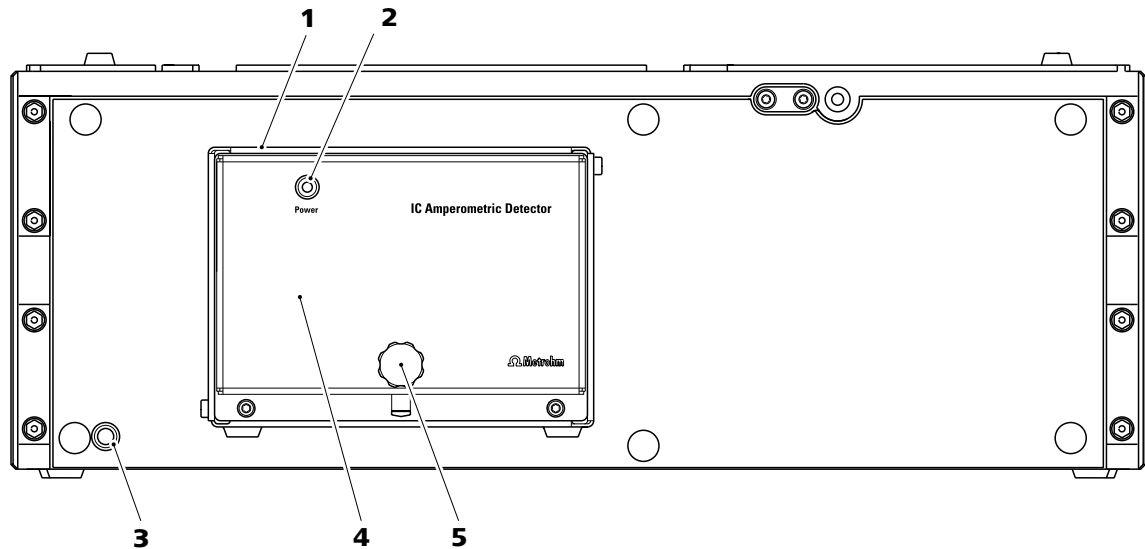

Figure 1 Front

1 Amperometric detector

Permanently installed.

3 Power LED

Standby indicator instrument.

5 Knurled screw

For removing the front lid.

2 Power LED

Standby indicator detector.

4 Front lid

For the amperometric detector.

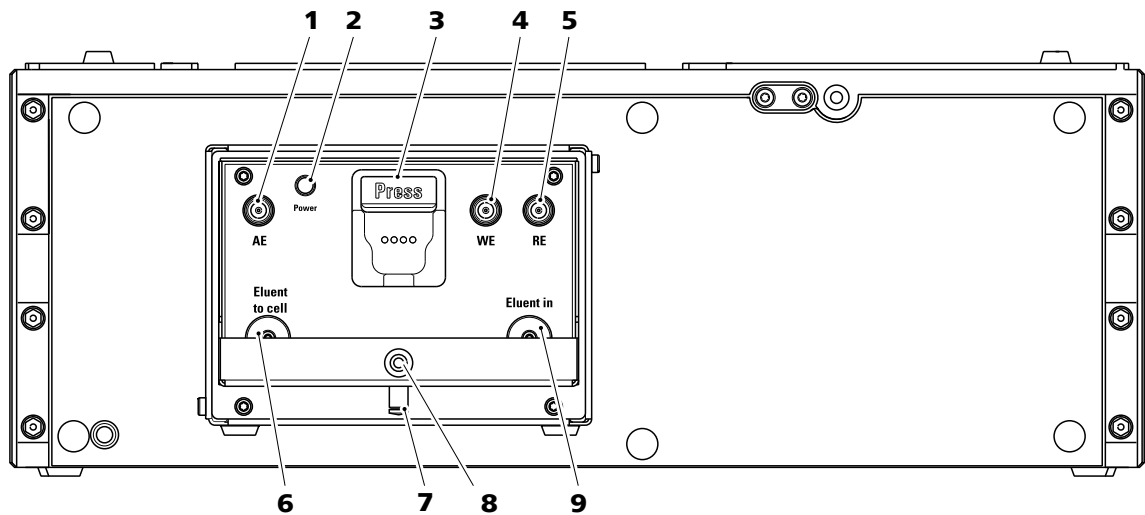

Figure 2 Front - open

1 Auxiliary electrode socket

For connecting the auxiliary electrode.
Labeled with **AE**.

3 Cell holder

With chip for the automatic detection of the measuring cell.

5 Reference electrode socket

For connecting the reference electrode.
Labeled with **RE**.

7 Drain nozzle

For draining liquid from the tray. Plugged with a stopper.

9 Coupling

For connecting a detector input capillary.
Labeled with **Eluent in**.

2 Power LED

Standby indicator detector.

4 Working electrode socket

For connecting the working electrode.
Labeled with **WE**.

6 Coupling

For connecting a connection capillary to the measuring cell. Labeled with **Eluent to cell**.

8 Thread

For the knurled screw used for fastening the front lid.



2.2 Rear

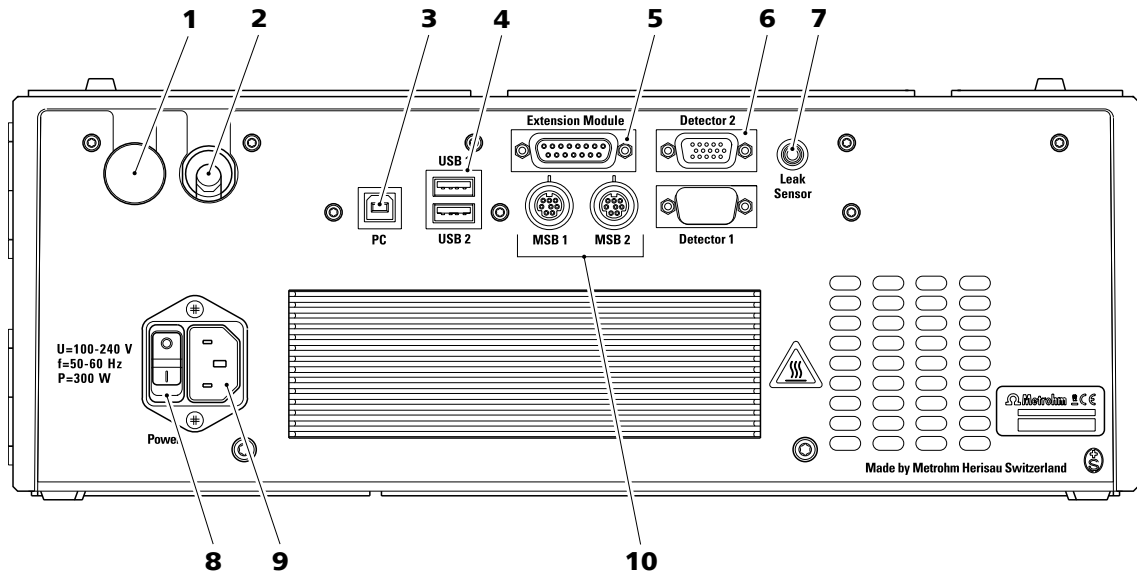

Figure 3 Rear

1 Stopper

Closes off unused cable feed-through.

2 Cable feed-through

Output for detector cable.

3 PC connection socket

For connecting the instrument to the computer with the USB cable (6.2151.020).

4 USB connection sockets

Two USB connection sockets, labeled with **USB 1** and **USB 2**.

5 Extension Module connection socket

For connecting an 872 Extension Module or an 891 Professional Analog Out. Labeled with **Extension Module**.

6 Detector connection sockets

For the connection of the installed detector, labeled with **Detector 1** and **Detector 2**. The detector connection sockets which are not used must be covered with a lid.

7 Leak sensor connection socket

For connecting the Leak sensor connector plug, labeled with **Leak Sensor**.

8 Mains switch

For switching the instrument on and off.

9 Mains cable connection socket

For connecting the mains cable (6.2122.0x0).

10 MSB connection sockets

Two MSB connection sockets for connecting instruments with MSB connection. Labeled with **MSB 1** and **MSB 2**.
(MSB = Metrohm Serial Bus)

3 Installation

3.1 Setting up the instrument

3.1.1 Packaging

The instrument is supplied in highly protective special packaging together with the separately packed accessories. Keep this packaging, as only this ensures safe transportation of the instrument.

3.1.2 Checks

Immediately after receipt, check whether the shipment has arrived complete and without damage by comparing it with the delivery note.

3.1.3 Location

The instrument has been developed for operation indoors and may not be used in explosive environments.

Place the instrument in a location of the laboratory which is suitable for operation and free of vibrations and which provides protection against corrosive atmosphere and contamination by chemicals.

The instrument should be protected against excessive temperature fluctuations and direct sunlight.

The distance between the rear of the instrument and the wall must be large enough to secure air circulation on the cooling plate.

3.1.4 Proposed setup

One option is to install the 896 Professional Detector – Amperometry directly above an 850 IC instrument. To accomplish this, the bottle holder of the IC instrument must be removed and then be placed back on the 896 Professional Detector – Amperometry (*see Chapter 3.2, page 10*).

The other option is to position the 896 Professional Detector – Amperometry directly underneath the 850 IC instrument. To accomplish this, the base tray of the IC instrument must be removed and then be placed back on underneath the 896 Professional Detector – Amperometry (*see Chapter 3.2, page 10*).

As an alternative, the 896 Professional Detector – Amperometry can be set up together with other instruments using the same support surface in one separate stack next to the IC instrument. We recommend that one bottle holder (6.2061.100) and one base tray (6.2061.110) be mounted for each stack of IC instruments.

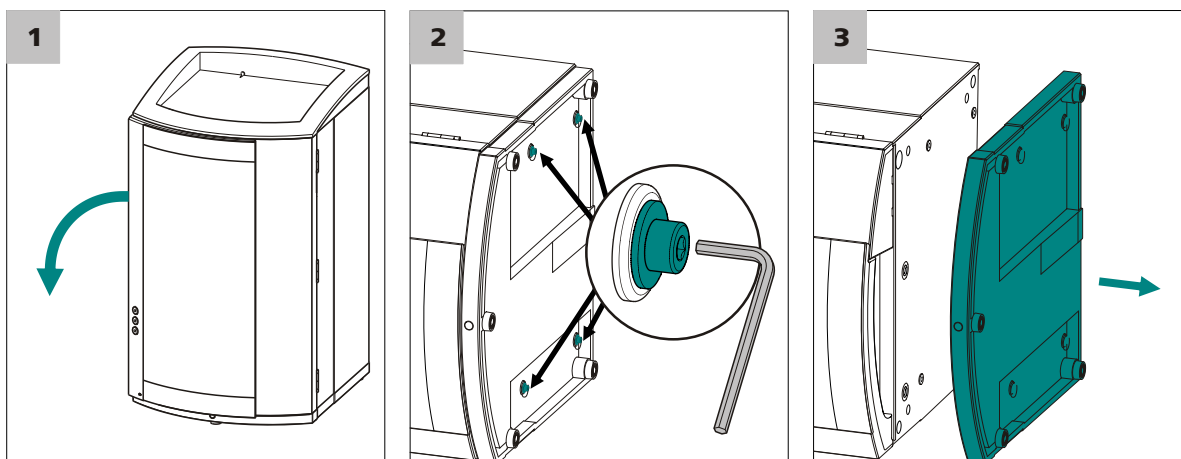

- 1** Tilt the instrument sideways and lay it down flat.
- 2** Loosen the cylinder screws with the 3 mm hexagon key and remove them and their washers.
- 3** Remove the base tray.

The base tray must always be mounted under the lowermost instrument of the stack. Proceed as follows:

Mounting the base tray

Before you can mount the base tray, the following preconditions must be met:

- The instrument is switched off.
- The bottle holder is cleared.
- All connections at the rear of the instrument are disconnected.
- There are no loose parts in the instrument.
- The instrument is lying on its side, and the bottom surface is visible.

To mount the base tray, you need a 3 mm hexagon key (6.2621.100).

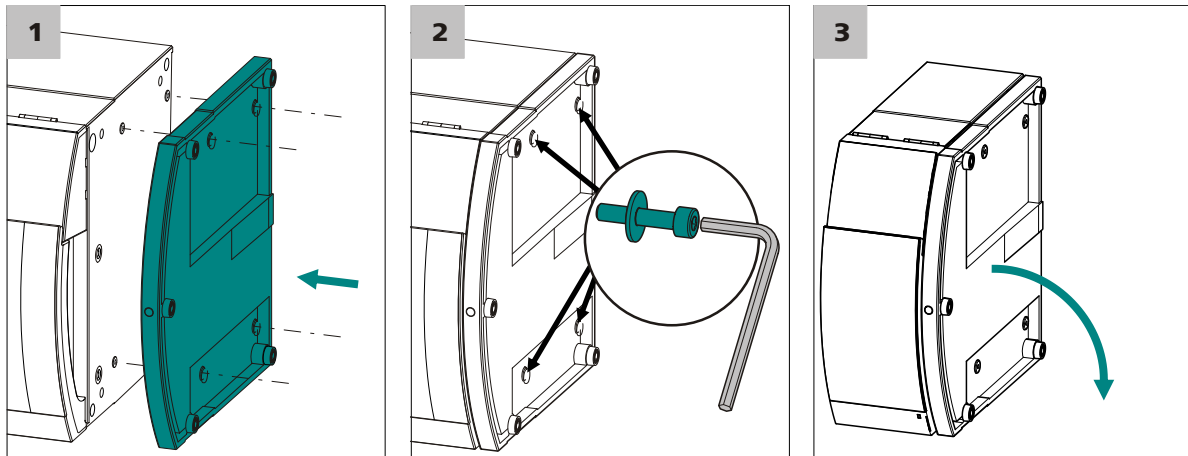

- 1 Place the base tray in such a way that the openings in the base tray match exactly the screw threads in the bottom of the instrument.
- 2 Slide the four washers onto the four cylinder screws, insert the screws and tighten them with the 3 mm hexagon key.
- 3 Set the instrument up on the base tray.

Stack other instruments in the required order. Mount the bottle holder (6.2061.100) onto the topmost instrument on the stack (see "Mounting the bottle holder", page 13).

3.2.2 Removing / mounting the bottle holder

The bottle holder must be removed in case you want to mount another instrument on top of the IC instrument. Proceed as follows:

Removing the bottle holder

Before you can remove the bottle holder, the following preconditions must be met:

- The instrument is switched off.
- The bottle holder is cleared.
- Drainage tubing is disconnected from the drainage tubing connection of the bottle holder.

To remove the bottle holder, you need a 3 mm hexagon key (6.2621.100).

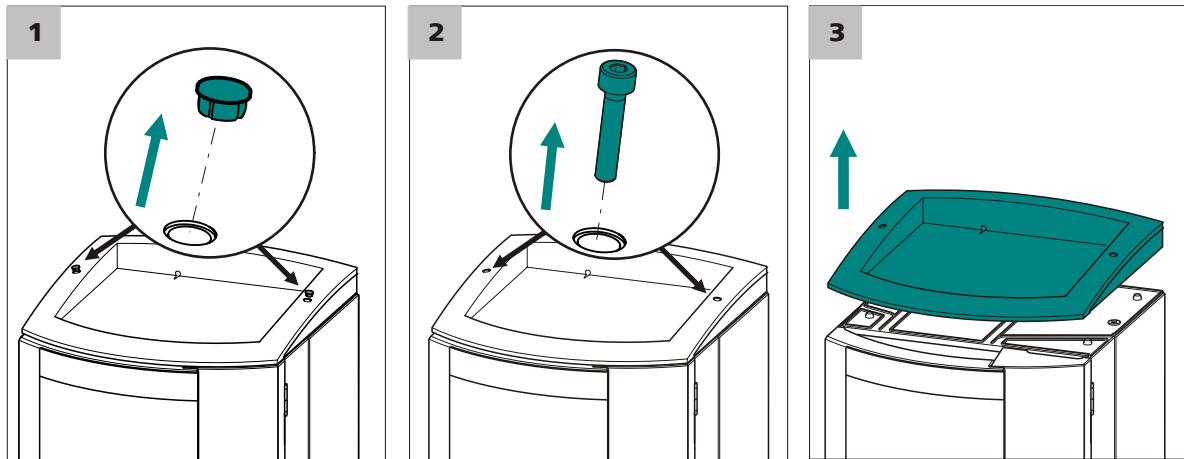

1 Remove the two covering stoppers.

2 Loosen the two cylinder screws with the 3 mm hexagon key and remove them.

3 Remove the bottle holder.

Stack other instruments in the required order. Mount the bottle holder (6.2061.100) onto the topmost instrument on the stack (see "Mounting the bottle holder", page 13).

Proceed as follows:

Mounting the bottle holder

Before you can mount the bottle holder, the following preconditions must be met:

- The instrument is switched off.

To mount the bottle holder, you need a 3 mm hexagon key (6.2621.100).

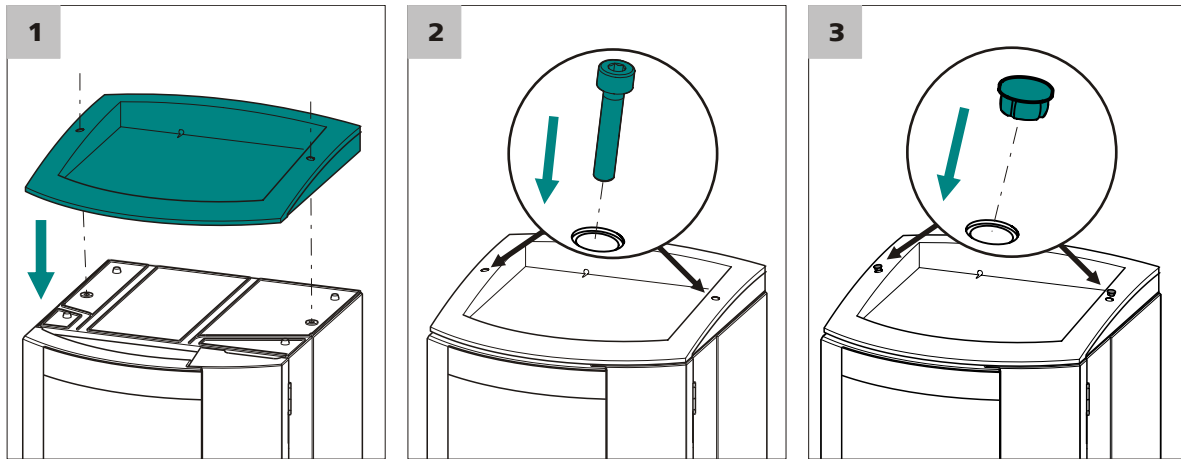

- 1** Place the bottle holder onto the topmost instrument in such a way that the openings in the bottle holder exactly match the screw threads on the top surface of the instrument.
- 2** Insert the two cylinder screws and tighten them with the 3 mm hexagon key.
- 3** Insert covering stoppers.

After having attached the bottle holder, all connections which were undone at the beginning of the process, must be reconnected. Proceed as follows:

Restoring the loosened connections

- 1** Plug in the USB cable.
- 2** Plug in the MSB cable.
- 3** Plug in the mains cable.
- 4** Mount the drainage tubings again (*see manual of the IC instrument*).
Possibly, a longer section of silicone tubing (6.1816.020) must be cut to fit and mounted (*see also the manual for the IC instrument*).
- 5** If one of the instruments in the stack is equipped with a leak sensor connection socket, connect the leak sensor (*see manual of the IC instrument*).

3.3 Amperometric detector

The following tasks are part of the installation of the amperometric detector:

- Inserting the working electrode and the reference electrode into the measuring cell (see the measuring cell manual).
- Connecting the capillaries to the preheating capillary or directly to the measuring cell.
- Inserting the measuring cell into the detector.
- Deaerating the measuring cell.
- Connecting the electrode cables.
- Attaching the front lid.

Because not only the capillaries but also the electrode cables must be tested prior to their first use, none of these installation tasks are carried out until the time of the first start-up.

3.4 Connecting the instrument

3.4.1 Connecting the instrument to the PC



Note

The instrument must be switched off when connecting the PC.

1 Connecting the USB cable

Connect the PC connection socket of the instrument to a USB connector of the computer via the USB cable (6.2151.020).

3.4.2 Connecting the instrument to power supply



Warning

The power supply unit must not get wet. Protect it against the direct effect of liquids.

Power supply cable

Which power supply cable is supplied depends on the location:

- 6.2122.020 with plug SEV 12 (Switzerland, ...)
- 6.2122.040 with plug CEE(7), VII (Germany, ...)
- 6.2122.070 with plug NEMA 5-15 (USA, ...)



The power supply cable is three-core and provided with a plug with grounding. If another plug has to be mounted, the yellow/green conductor (IEC standard) must be connected to the protective ground (protection class I).

1 Connecting the power supply cable

- Plug the power supply cable into the power socket .
- Connect the power supply cable to the power supply.

2 Switching on the instrument

Switch on the instrument using the power switch .

After switching on, the LED on the front of the instrument flashes while a system test is carried out and the connection to the software is established. Once the system test is complete and the connection to the software has been established, the LED lights up continuously.

4 Start-up

The 896 Professional Detector – Amperometry is set to work together with the IC instrument. Additional information can be found in the *Start-up* chapter in the manual for the IC instrument.

The following tests and installation tasks must be performed during the first start-up of the IC device with the 896 Professional Detector – Amperometry.

4.1 Instrument test with dummy cell

When you are putting the 896 Professional Detector – Amperometry into operation for the first time, or when problems occur which may be caused by signal recording or signal transfer, we recommend to test the electronics and the connection to the PC using the dummy cell (6.2813.040).

Proceed as follows:

Testing with the dummy cell

Preconditions:

- In order to achieve accurate results, we recommend that the lid be closed during the instrument test with the dummy cell. Since the space under the front lid is rather limited, we further recommend to remove the measuring cell from the cell holder for the instrument test with the dummy cell.

For the instrument test you require:

- The dummy cell (6.2813.040)
- The electrode connection cables (6.2165.000)

1 Connect the electrode connection cables to the dummy cell

- Plug in the angled plug of the working electrode connection cable (labeled with **WE**) into the **WE** socket.
- Plug in the angled plug of the reference electrode connection cable (labeled with **RE**) into the **RE** socket.
- Plug in the angled plug of the auxiliary electrode connection cable (labeled with **AE**) into the **AE** socket.

2 Connect the electrode connection cables to the detector

(unless they are already connected)



- Plug in the straight plug of the working electrode connection cable (red sleeve) into the **WE** socket of the detector.
- Plug in the straight plug of the reference electrode connection cable (black sleeve) into the **RE** socket of the detector.
- Plug in the straight plug of the auxiliary electrode connection cable (blue sleeve) into the **AE** socket of the detector.

3 Insert the dummy cell

- Place the dummy cell into the tray of the detector.
- Attach the front lid.



Note

The metal parts of the cable plugs must not touch the front lid.

4 Adjust settings in MagIC Net™

In the program part **Method**, create a new method for the instrument test with the dummy cell.

- Select the detector and add it as a new device.
- Select the DC mode.
- Set the following parameters for the DC mode:
 - **DC potential: 0.8 V**
 - **Range: Auto**
 - **Damping: off**
- Add an analysis for the detector channel **Current**.
- Save the method.

In the program part **Workplace**:

- Load the method.
- In the **Watch window**, display the **Current** channel with at least 3 decimal places.

5 Carry out the test

In the program part **Manual**:

- Switch on the cell
After no more than 1 minute, the detector signal should level off at $2.667 \text{ nA} \pm 7 \%$. Noise should not exceed 0.005 nA .

- Switch off the cell
With the cell switched off and detector hardware still running, the signal should fall under 1 nA absolutely and noise be restrained to the third decimal place.
Exactly even signals may indicate that new detector data is not correctly transmitted.

The dummy cell incorporates a resistor (300 M Ω) and a capacitor (100 μ F) connected in parallel. If, in DC mode, a voltage of 0.8 V is applied, then a current of 2.667 nA (± 7 %) is measured in the dummy cell. The capacitor works as a noise generator and simulates a well-working measuring cell.

4.2 Testing the leak sensor

The leak sensor should not respond during the start-up. If the leak sensor nevertheless does respond during the start-up, you will find information for eliminating the problem in Chapter (see *Chapter 6.1, page 31*).

To check whether the leak sensor is functioning, proceed as follows:

Testing the leak sensor

- 1 Hold a cloth moistened with eluent or tap water on the two contacts of the leak sensor .

The leak sensor of the detector responds.

If the leak sensor does not respond, please request Metrohm Service.

4.3 Testing the preheating capillary

The amperometric detector has a preheating capillary in its interior that ensures that the eluent flows through the measuring cell at a constant temperature. The preheating capillary need not however always be connected. If the ambient conditions are optimal, then the measuring results can be sufficiently accurate, even without the use of the preheating capillary.



Caution

The preheating capillary may not be used when working with readily flammable liquids.

The preheating capillary must be free of both leaks and blockages.



To check whether the preheating capillary is free of both leaks and blockages, proceed as follows:

Testing the preheating capillary

1 Connect the detector input capillary

Use a pressure screw (6.2744.014) to fasten the detector input capillary to the connector **Eluent in** on the detector.

2 Adjust settings in MagIC Net™

- In the program part **Manual** of MagIC Net™, set the maximum pressure of the high pressure pump to 5 MPa.
- Set the flow to 0.1 mL/min.
- Start the high pressure pump.

3 Observe the Eluent to cell connector

After a while, liquid must emerge from the **Eluent to cell** connector (wipe up fluid with paper towel).

If no liquid emerges at the **Eluent to cell** connector, then the preheating capillary is likely to be blocked. To eliminate the problem, see *Chapter Preheating capillary maintenance, page 29*.

4 Observe the pump pressure

Observe the pump pressure display in the program part **Manual** of MagIC Net™.

A constant pressure should establish itself after a while.

4.4 Testing the detector output capillary

The detector output capillary must be of a certain length in order to be able to generate sufficient backpressure. The required length is dependent on the flow that has been set. *The table 1* shows the recommended lengths, as determined by the set flow.

Table 1 Recommended lengths for the detector output capillary

Flow	Capillary length (ø0.25 mm)
2.0 mL/min	0.5...1.5 m
0.5...1.0 mL/min	1.0...2.5 m
0.25 mL/min	3 m

To check whether the detector output capillary is free of blockages, proceed as follows:

Testing the detector output capillary

Prerequisites:

- The detector input capillary is connected to the **Eluent in** connector.
- The high pressure pump runs with a flow of 0.1 mL/min.

1 Connect the detector output capillary

Use a pressure screw (6.2744.014) to fasten the detector output capillary to the **Eluent to cell** connector.

2 Adjust settings in MagIC Net™

In the program part **Manual** of MagIC Net™, increase the flow to 1.0 mL/min and wait until the pressure has stabilized.

3 Observe the end of the detector output capillary

After a while, liquid must emerge from the end of the detector output capillary.

If no liquid emerges at the end of the detector output capillary, then the detector output capillary is blocked and must either be cut back once again or replaced.

4 Loosen the detector output capillary

Release the detector output capillary from the **Eluent to cell** connector. Wipe up emerging liquid with a cloth.

5 Observe the pump pressure

Observe the pump pressure display in the program part **Manual** of MagIC Net™.

The drop in pressure should range from 0.1 MPa to a maximum of 0.3 MPa.

If the pressure differential is greater, then the detector output capillary must be cut back once again or replaced.

6 Finish the test

- In the program part **Manual** of MagIC Net™, stop the high pressure pump.
- Remove the detector output capillary from the **Eluent to cell** connector.



4.5 Testing the measuring cell

To test the measuring cell, proceed as follows:

Testing the measuring cell

Preconditions:

- The measuring cell is completely assembled (see measuring cell manual).
- The working electrode and the reference electrode are inserted (see measuring cell manual).

1 Connect the measuring cell

- Connecting the measuring cell input:
 - *When the preheating capillary is used:* Use a pressure screw (6.2744.014) to fasten a piece of the PEEK capillary (6.1831.010) to the **Eluent to cell** connector on the detector.
Use a pressure screw (6.2744.014) to fasten the other end to the **In** connector on the measuring cell.
 - *If the preheating capillary is not used:* Use a pressure screw (6.2744.014) to fasten the detector input capillary directly to the **In** connector on the measuring cell.
- Connecting the measuring cell output:
Use a pressure screw (6.2744.014) to fasten the tested detector output capillary to the **Out** connector on the measuring cell (see "Testing the detector output capillary", page 21).

2 Insert the measuring cell

Insert the chip of the measuring cell into the cell holder so that you can hear it locking in.

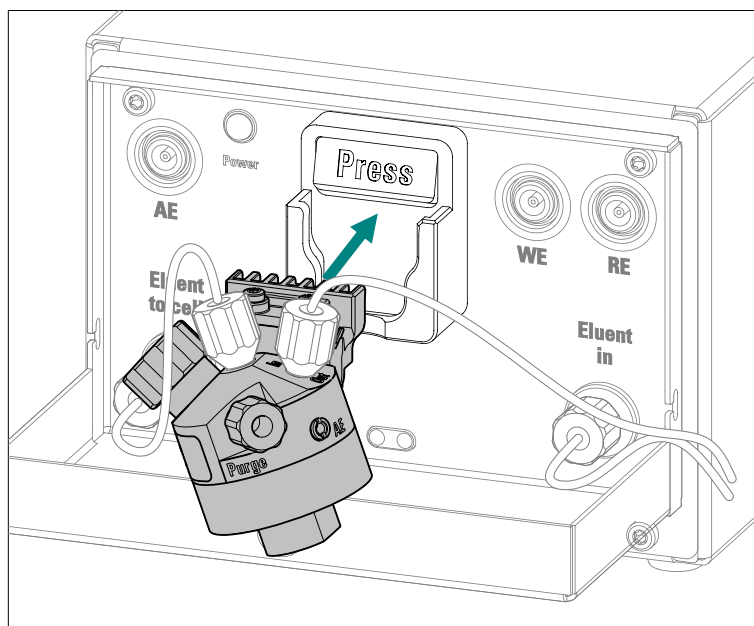

Note

Do not move the measuring cell for at least 5 seconds after having inserted it.

During this time, data is read from the chip of the measuring cell and written into the database. This process must not be interrupted, because otherwise the data may be transferred incorrectly or incompletely.

3 Test at low flow

- In the program part **Manual** of MagIC Net™, set the flow of the high pressure pump to 0.2 mL/min and start the high pressure pump.
- Watch the detector output capillary: Liquid must emerge from the end of the detector output capillary.
 - If no liquid emerges from the end of the detector output capillary:
 - Undo the capillary from the **Out** connection on the measuring cell and check whether the end has been squeezed by the pressure screw.
 - Shorten the capillary and fasten once again to the **Out** connector on the measuring cell.



- Observe the measuring cell: No liquid should emerge from the body of the measuring cell.
If the measuring cell is leaking:
 - Remove the measuring cell from the measuring cell holder.
 - Remove all capillaries and cables.
 - Check the seating of the pressure screw of the working electrode and retighten it.
 - Restore the capillary connections.
 - Reinsert the electrode cables.
 - Reinsert the measuring cell.
 - Repeat the test.

4 Test at normal flow

- In the program part **Manual** of MagIC Net™, raise the flow of the high pressure pump to 1.0 mL/min.
- Observe the measuring cell: No liquid should emerge from the body of the measuring cell.

4.6 Deaerating the measuring cell

The cell must be deaerated in order to ensure that it contains no air bubbles.

The measuring cell must be deaerated after the installation and after each subsequent opening of the cell.

Proceed as follows:

Deaerating the measuring cell

Prerequisites:

- The high pressure pump is switched on and pumps the eluent through the IC system to the measuring cell.
- The measuring cell is switched off.

1 Deaerate the reference electrode chamber

- Unscrew the nut on the RE connector and remove it.
- Lift out the reference electrode.
- Wait until the reference electrode chamber has filled with eluent.
- Reinsert the reference electrode. Wipe up any emerging eluent with a cloth.
- Screw the nut on the reference electrode connector back on tightly.

2 Remove the purge stopper

Remove the stopper from the **Purge** connector.

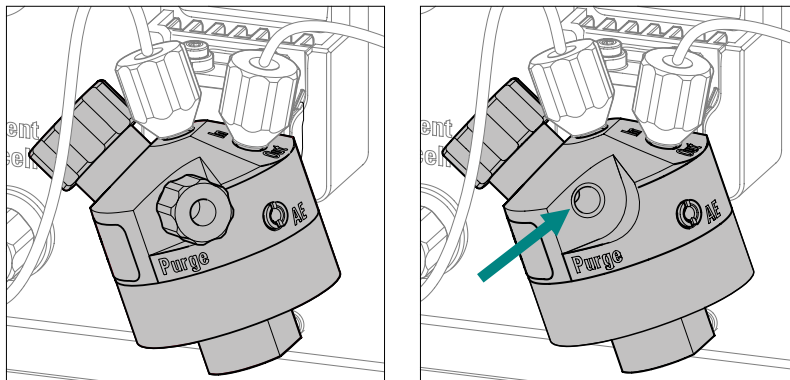
**3 Deaerate the measuring cell**

Observe the eluent that emerges through the deaeration opening. Wipe up liquid with a cloth.

Once no more air bubbles are visible, screw the stopper back on the **Purge** connector and tighten it by hand.

4 Switch off the high pressure pump in MagIC Net™.**4.7 Connecting the electrode connection cables****Connecting the electrode connection cables to the detector**

Precondition: The electrode connection cables are connected to the measuring cell (see chapter *installation* in the manual of the measuring cell).

- 1** Plug in the straight plug of the working electrode connection cable (red sleeve) into the **WE** socket of the detector.
- 2** Plug in the straight plug of the reference electrode connection cable (black sleeve) into the **RE** socket of the detector.
- 3** Plug in the straight plug of the auxiliary electrode connection cable (blue sleeve) into the **AE** socket of the detector.

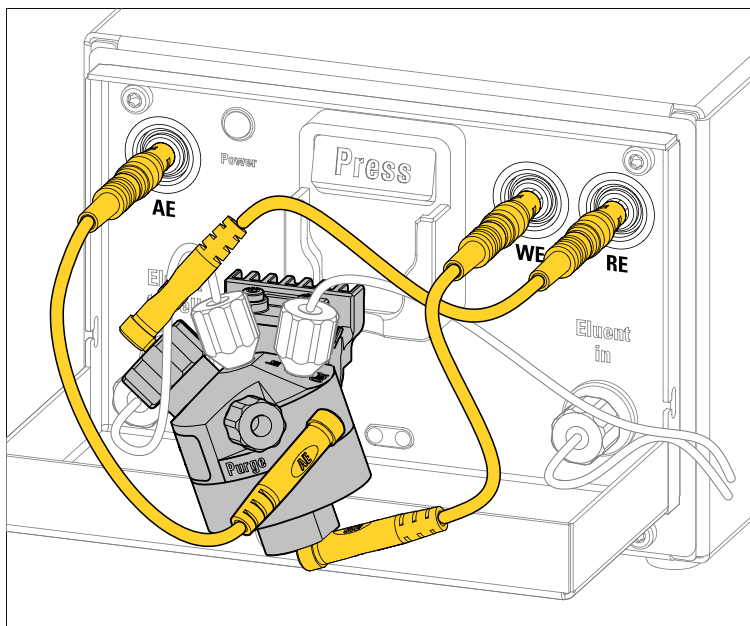

Inserting the measuring cell into the cell holder

- 1 Insert the chip of the measuring cell into the cell holder so that you can hear it locking in.

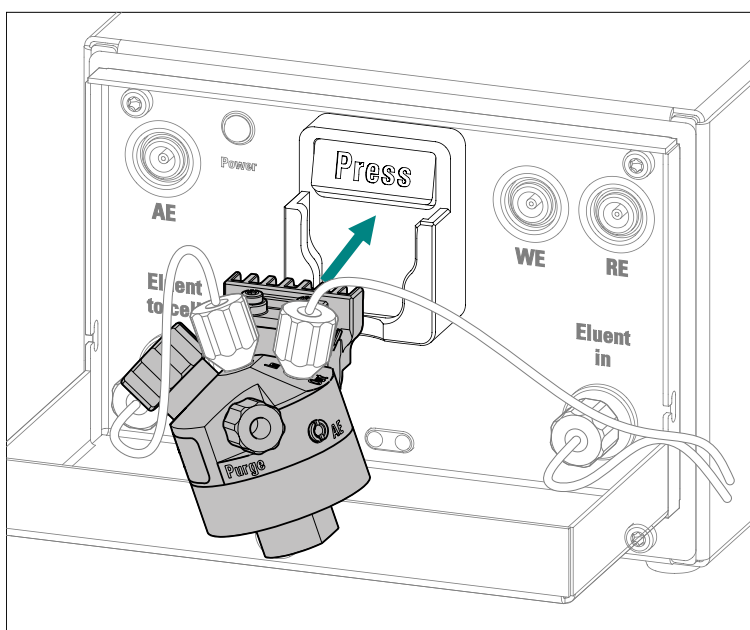

**Note**

Do not move the measuring cell for at least 5 seconds after having inserted it.

During this time, data is read from the chip of the measuring cell and written into the database. This process must not be interrupted, because otherwise the data may be transferred incorrectly or incompletely.

The measuring cell is now correctly connected.

4.8 Attaching the front lid

In order to obtain good measuring results, we recommend that the front lid be put back in place.

When you are attaching the front lid, observe the following:

- Do not pinch any capillaries!
Guide the capillaries through the capillary feed-throughs .
- Do not pinch any cables!



5 Operation and maintenance

5.1 General notes

5.1.1 Care



Warning

The instrument housing must not be opened by untrained personnel.

The instrument requires appropriate care. Excess contamination of the instrument may result in functional disruptions and a reduction in the life-time of the sturdy mechanics and electronics.



Caution

Even though design measures ensure that this will largely be prevented, the detector should be switched off without delay in the event that aggressive media have found their way into the interior of the detector. It is only thus that massive damage to the instrument electronics can be prevented. In such cases, Metrohm Service must be informed.

Spillages of chemicals and solvents should be cleaned up immediately. In particular, the plug connections on the rear panel of the instrument (especially the mains plug) should be protected from contamination.

Do not use scouring agents for cleaning the tray.

5.1.2 Maintenance by Metrohm Service

Maintenance of the instrument is best carried out as part of an annual service, which is performed by specialist personnel from Metrohm. If working frequently with caustic and corrosive chemicals, a shorter maintenance interval is recommended. Metrohm Service offers every form of technical advice for maintenance and service of all Metrohm instruments.

5.1.3 Operation



Caution

In order to avoid disturbing temperature influences, the entire system must be protected against direct sunlight.

5.1.4 Shutting down

If the instrument is shut down for a longer period of time, the entire IC system must be rinsed as follows to rid it of salts in order to prevent eluent salts from forming crystals which may cause subsequent damage.

- Rinse all capillaries and the Dosino (if present) with methanol/ultrapure water (1:4),
- rinse all pump tubings of the peristaltic pump with ultrapure water.

5.2 Amperometric detector

5.2.1 Maintenance



Warning

When **rinsing the detector without column**, the pressure must not exceed **5 MPa**.

In order to ensure this, set the maximum pressure of the high pressure pump to **5 MPa** in MagIC Net™.

5.2.2 Preheating capillary maintenance

The preheating capillary can become blocked, e.g. if the IC system has inadvertently been run dry.

To dissolve this blockage, proceed as follows:

Rinsing the preheating capillary

1 Remove the separation column

Remove the separation column from the IC system and replace with a coupling (6.2744.040).

2 Adjust settings in MagIC Net™

In MagIC Net™, adjust the following settings:

- Maximum pressure of the high pressure pump: 5 MPa
- Flow rate: < 0.1 mL/min

3 Rinse the system with the same eluent as before the blockage or with ultrapure water.

The eluent requires sufficient time to trickle through and dissolve the crystals.



- 4 Do not increase the flow rate until the pressure has stabilized.

If the preheating capillary remains blocked, then you can attempt to rinse the capillary in the opposite direction. To accomplish this, connect the detector input capillary to the connector **Eluent to cell** and repeat the procedure (see "Rinsing the preheating capillary", page 29).

If the blockage can also not be dissolved by rinsing in the opposite direction, then the preheating capillary must be replaced by a Metrohm Service employee.

5.3 Quality Management and validation with Metrohm

Quality Management

Metrohm offers you comprehensive support in implementing quality management measures for instruments and software. Further information on this can be found in the brochure «**Quality Management with Metrohm**» available from your local Metrohm agent.

Validation

Please contact your local Metrohm agent for support in validating instruments and software. Here you can also obtain validation documentation to provide help for carrying out the **Installation Qualification** (IQ) and the **Operational Qualification** (OQ). IQ and OQ are also offered as a service by the Metrohm agents. In addition, various application bulletins are also available on the subject, which also contain **Standard Operating Procedures** (SOP) for testing analytical measuring instruments for reproducibility and correctness.

Maintenance

Electronic and mechanical functional groups in Metrohm instruments can and should be checked as part of regular maintenance by specialist personnel from Metrohm. Please ask your local Metrohm agent regarding the precise terms and conditions involved in concluding a corresponding maintenance agreement.



Note

You can find information on the subjects of quality management, validation and maintenance as well as an overview of the documents currently available at www.metrohm.com/com/ under **Support**.

6 Troubleshooting

6.1 Problems with the hardware

Problem	Cause	Remedy
Leak sensor responds.	<i>Leaking capillary connection.</i>	Find any leaking capillary connections and seal them.
	<i>Measuring cell leaking.</i>	Screw apart the measuring cell and then reassemble it.
The amperometric detector is not recognized in the software.	<i>IC system – No connection.</i>	<ul style="list-style-type: none"> ▪ Check the cable connection. ▪ Switch the IC instrument off and on again (after 15 seconds).

6.2 Problems with the baseline

Problem	Cause	Remedy
Drift of the baseline.	<i>IC system – Thermal equilibrium not yet attained.</i>	Condition the system with the heater switched on.
	<i>IC system – Leak in the system.</i>	Check capillary connections and seal them.
	<i>IC system – Eluent is old (too much CO₂).</i>	Apply new eluent.
Pulsing baseline.	<i>High pressure pump – contaminated valves.</i>	Clean valves (see <i>Chapter Handling and maintenance</i> in the manual for the IC instrument).
	<i>High pressure pump – defective piston seal.</i>	Replace piston seals (see <i>Chapter Handling and maintenance</i> in the manual for the IC instrument).
	<i>High pressure pump – Quality of the pump is not sufficient for the selected sensitivity.</i>	<ul style="list-style-type: none"> ▪ Use pulsation absorber. ▪ Use a higher-performance high pressure pump. ▪ Reduce sensitivity.
	<i>Measuring cell – Air bubble in the measuring cell.</i>	<ul style="list-style-type: none"> ▪ Deaerate the measuring cell. ▪ Degas the eluent continuously.



Problem	Cause	Remedy
	<i>IC system – temperature fluctuations.</i>	<ul style="list-style-type: none"> ▪ Switch on column thermostat or column oven, respectively. ▪ Amperometric detector – Connect preheating capillary ▪ Amperometric detector – Attach and close front cover (see Chapter 4.8, page 27).
	<i>Measuring cell – Working electrode contaminated.</i>	Clean the working electrode (see the leaflet for the working electrode).
	<i>Measuring cell – Measuring cell leaking.</i>	Check capillary connections on the measuring cell.
	<i>IC system – Eluent contaminated.</i>	Apply new eluent.
Smooth baseline (no noise).	<i>Communications problem between the amperometric detector and MagIC Net™.</i>	<ul style="list-style-type: none"> ▪ Check the seating of the electrode cable. ▪ Check the electrode cable with dummy cell (see Chapter 4.1, page 17). ▪ Switch off the instrument, close and restart MagIC Net™, switch instrument back on.
	<i>All of the data lies outside of the measuring range.</i>	<ul style="list-style-type: none"> ▪ Adjust measuring range. ▪ Deaerate the measuring cell (see "Deaerating the measuring cell", page 24).
	<i>Short-circuit bridge between the electrodes.</i>	<ul style="list-style-type: none"> ▪ Examine the working electrode for prominent deposits. ▪ Polish the working electrode (see the leaflet for the working electrode). ▪ Replace the working electrode . ▪ Clean the measuring cell . ▪ Check spacers.
	<i>Reference electrode worn out.</i>	Replace the reference electrode .
	<i>The cause is not clear.</i>	Perform systematic error diagnostics (see Chapter 6.9, page 38).
Unexpectedly high or low baseline.	<i>Pd reference electrode – Working conditions not yet achieved.</i>	Equilibrate until the electrode has adjusted to the new elution conditions (over night).
	<i>DC method – Working conditions not yet achieved.</i>	An excessively high baseline is normal at the start of the equilibration. Equilibrate until the

Problem	Cause	Remedy
		baseline corresponds to the one in the Application Works.
	<i>Detector parameters – Potentials set incorrectly.</i>	Set the potentials to correspond to the specifications in the leaflet and in the Application Works.
	<i>Incorrect eluent in the reference chamber.</i>	Remove purge stopper on the measuring cell, wait until approx. 1 mL of eluent has emerged, screw the purge stopper back in tightly.
	<i>Electrodes contaminated.</i>	<ul style="list-style-type: none"> ▪ Clean and polish working electrode. ▪ Possibly clean the auxiliary electrode. ▪ Replace the reference electrode with a well-conditioned new reference electrode.
Very noisy baseline.	<i>Disruptive influences from outside.</i>	<ul style="list-style-type: none"> ▪ In the DC mode: Switch on the damping. ▪ In the other measuring modes: Set a suitable smaller measuring range. ▪ Attach the front lid.
	<i>Ag/AgCl reference electrode worn out.</i>	Replace the reference electrode .
	<i>Auxiliary electrode contaminated.</i>	Clean the auxiliary electrode of the measuring cell .
	<i>Working electrode contaminated.</i>	<ul style="list-style-type: none"> ▪ Clean and polish the working electrode (see the leaflet for the working electrode). ▪ Replace the GC working electrode if it has been used with oxidative potentials at the upper limit and polishing no longer helps.
	<i>Air bubble in the measuring cell.</i>	Deaerate the measuring cell (<i>see Chapter 4.6, page 24</i>).
	<i>Background current too high, e.g. caused by contaminated eluent.</i>	Check the background current, e.g. use fresh eluent.



6.3 General remarks regarding sensitivity fluctuations

Sensitivity fluctuations of up to 20% per week are normal for an unchanged system in constant operation.

The sensitivity can increase to approximately twice as much for a short time when new working electrodes are inserted or when the conditions change.

6.4 Problems with sensitivity

Problem	Cause	Remedy
Declining sensitivity.	<i>Measuring cell – Auxiliary electrode contaminated.</i>	Clean the auxiliary electrode (see measuring cell manual).
	<i>Incorrect eluent in the reference chamber.</i>	Remove purge stopper on the measuring cell, wait until approx. 1 mL of eluent has emerged, screw the purge stopper back in tightly.
	<i>Sample concentration is no longer correct.</i>	Replace sample and/or standard solution.
	<i>Temperature fluctuations.</i>	<ul style="list-style-type: none"> ▪ Amperometric detector – Use preheating capillary. ▪ IC instruments – Use column oven.
	<i>Replace the measuring cell.</i>	<ul style="list-style-type: none"> ▪ Use a measuring cell of the same type. ▪ Use the same spacer. ▪ Use the same electrodes.
	<i>Software – Measurement potential incorrect.</i>	Optimize the measurement potential.
	<i>Measuring cell – Working electrode contaminated.</i>	Clean the working electrode (see the leaflet for the working electrode).
	<i>IC system – Eluent contaminated.</i>	Apply new eluent.
<i>IC system – pH of the eluent has changed.</i>	Check the pH of the eluent and optimize it if necessary.	

6.5 Problems with the pressure

Problem	Cause	Remedy
Marked drop in pressure.	<i>IC system – Leak in the system.</i>	Check capillary connections and seal them.
Marked rise in pressure.	<i>IC system – Inline filter blocked.</i>	Replace filter platelets (see <i>Chapter Handling and maintenance</i> in the manual for the IC instrument).
	<i>IC system – Separation column contaminated.</i>	<ul style="list-style-type: none"> ▪ Regenerate the separation column (see <i>Chapter Handling and maintenance</i> in the manual for the IC instrument). ▪ Replace the separation column (see <i>Chapter Handling and maintenance</i> in the manual for the IC instrument). <p>Note: Samples should always be micro-filtered (see <i>Chapter Handling and maintenance – Inline sample preparation</i> in the manual for the IC instrument).</p>
	<i>Amperometric detector – Preheating capillary blocked.</i>	Preheating capillary maintenance (see <i>Chapter 5.2.2, page 29</i>).
	<i>Amperometric detector – Detector output capillary not free of blockage.</i>	Test the detector output capillary (see <i>Chapter 4.4, page 20</i>).

6.6 Problems with the measuring signal

Problem	Cause	Remedy
Measuring signal "overload".	<i>Air bubble in the measuring cell.</i>	Deaerate the measuring cell (see <i>Chapter 4.6, page 24</i>).
	<i>Measuring cell – Working electrode damaged.</i>	Replace working electrode.
	<i>Measuring cell – Measuring cell not correctly connected.</i>	Check cable connections (see <i>Chapter 4.7, page 25</i>).
	<i>Software – Measurement potential incorrect.</i>	Optimize the measurement potential.



Problem	Cause	Remedy
No measuring signal.	<i>IC system – No mains current.</i>	Check mains connection and voltage.
Peaks cut off at the top.	<i>Measuring range too small.</i>	<ul style="list-style-type: none"> ▪ Set a less sensitive measuring range. ▪ Reduce peak height, e.g. by means of sample dilution.

6.7 Problems with the chromatogram

Problem	Cause	Remedy
Peak drift with sugar analysis.	<i>Carbonate absorption in the eluent.</i>	Use trap-column Metrosep CO3 Trap 1 (6.1015.300).
Peaks have poor resolution.	<i>IC system – Diminished separating efficiency of the separation column.</i>	<ul style="list-style-type: none"> ▪ Regenerate the separation column (see <i>Chapter Handling and maintenance</i> in the manual for the IC instrument). ▪ Replace the separation column (see <i>Chapter Handling and maintenance</i> in the manual for the IC instrument).
	<i>IC system – Eluent is old.</i>	Apply new eluent.
	<i>Ionic strength of the sample or pH of the sample deviates greatly from the eluent.</i>	Dilute the sample or optimize the pH of the sample.
	<i>Absorption of analyte at the electrodes.</i>	Use a suitable combination of electrodes and eluent.
Unexpected change to the retention times in the chromatograms.	<i>IC system – Diminished separating efficiency of the separation column.</i>	<ul style="list-style-type: none"> ▪ Regenerate the separation column (see <i>Chapter Handling and maintenance</i> in the manual for the IC instrument). ▪ Replace the separation column (see <i>Chapter Handling and maintenance</i> in the manual for the IC instrument).
	<i>IC system – Eluent is old.</i>	Apply new eluent.
	<i>Ionic strength of the sample or pH of the sample deviates greatly from the eluent.</i>	Dilute the sample or optimize the pH of the sample.

Problem	Cause	Remedy
Extreme spread of the peaks in the chromatogram. Splitting (dual peaks)	<i>IC system – Dead volume at the ends of the separation column.</i>	Replace separation column.
	<i>IC system – Dead volume in the IC system.</i>	Check the capillary connectors.
	<i>Inhibition of the detection mechanism by the analyte (with PAD).</i>	<ul style="list-style-type: none"> ▪ Dilute the sample. ▪ Allow the waveform to run-in better. ▪ Adjust the PAD waveform.
	<i>Overload the column.</i>	Dilute the sample.

6.8 Other problems

Problem	Cause	Remedy
High background current.	<i>IC system – Eluent contaminated.</i>	Apply new eluent.
	<i>Software – Measurement potential / pulse settings incorrect.</i>	Optimize parameters.
	<i>Very wide peaks through substances with delayed elution.</i>	Wait for the complete elution of these substances.
Unstable temperature.	<i>The set temperature is too low.</i>	Set the temperature to at least 8 °C higher than the highest ambient temperature to be anticipated.
Current display/ charge display in the software is frozen.	<i>Measuring cell – electrodes are either not connected or not correctly connected.</i>	Connect the electrode connection cables correctly (see Chapter 4.7, page 25).
	<i>Measuring cell – Small air bubbles in the measuring cell.</i>	Deaerate the measuring cell (see Chapter 4.6, page 24).
	<i>Measuring cell – Electrode connection cable defective.</i>	Perform instrument test with dummy cell (see Chapter 4.1, page 17).



6.9 Systematic error diagnostics

If the causes of a malfunction cannot be found among the problem descriptions in the above chapters, then proceed systematically as follows:

Systematic error diagnostics

1 Restarting the instrument and the software

- Switch off the instrument.
- Close and restart MagIC Net™.
- Switch the instrument back on again.

If the problem has not yet been localized, continue with Step 2.

2 Performing instrument test with dummy cell

(see Chapter 4.1, page 17)

If the problem has not yet been localized, continue with Step 3.

3 Checking software settings

- Check the method parameters of the detector and reset them to values that you know will function.
- Check the measuring range and reset it to values that you know will function or select a larger measuring range.
- Check manual changes to the settings and reset them to values that you know will function.
- Check manual settings in the time program and reset them to values that you know will function.

If the problem has not yet been localized, continue with Step 4.

4 Cleaning the measuring cell

- Switch off the measuring cell.
- Remove the measuring cell.
- Clean the measuring cell (see measuring cell manual).
- Polish the working electrode (see the leaflet for the working electrode).
- Reinsert the measuring cell.

If the problem has not yet been localized, continue with Step 5.

5 Replacing the reference electrode

If the problem has not yet been localized, continue with Step 6.

6 Replacing the working electrode

If the problem has not yet been localized, continue with Step 7.

7 Replacing the body of the measuring cell

Replace the body of the measuring cell with another one of the same type.

If the problem has not yet been localized, continue with Step 8.

8 Request Metrohm Service

If none of these measures help, please request Metrohm Service.

**Note**

Please note that, when the electrodes are replaced, the system requires a longer run-in time before the earlier values can be reproduced.



7 Technical specifications

7.1 Reference conditions

The technical data listed in this Chapter refers to the following reference conditions:

<i>Ambient temperature</i>	+25 °C (± 3 °C)
<i>Instrument status</i>	> 40 minutes in operation (equilibrated)

7.2 Amperometric detector

<i>Type</i>	Microprocessor-controlled Digital Signal Processing (DSP technology)
<i>Potentiostat</i>	
<i>Potential range</i>	−5.0...+5.0 V in steps of 0.001 V
<i>Potential step response time</i>	< 1 ms
<i>Detection modes</i>	<ul style="list-style-type: none"> ▪ DC ▪ PAD ▪ flexIPAD (flexible IPAD) ▪ CV
<i>Measuring unit</i>	
<i>AutoRange</i>	yes, (DC only)
<i>Digital signal range</i>	
<i>DC mode</i>	0.00012 pA...2 mA
<i>PAD mode</i>	0.012 pA...2 mA
<i>flexIPAD mode</i>	0.12 pC...200 µC
<i>CV</i>	0.12 pA...20 mA
<i>Electronic noise</i>	
<i>DC mode</i>	< 5 pA
<i>PAD mode</i>	< 10 pA
<i>flexIPAD mode</i>	< 30 pC
<i>Filter</i>	
<i>DC mode</i>	Hardware filter, can be selected by the user
<i>All modes</i>	Software filter, can be set by the user

Temperature control

Temperature stability at the heater better than 0.05 °C with ambient temperature +8 °C...80 °C

Operation

Direct Via Software MagIC Net™

Remote Via Remote Box

Analog output

With 891 Professional Analog Out

Output voltage 0...1000 mV

Full scale Can be adjusted within the digital signal range

Offset Can be adjusted within the digital signal range

System standby

- Automatic function test at start-up
- Leak sensor
- Temperature stability monitoring

Output channels

- Current rating
- Charge

GLP conformity

Yes, optional

7.3 Power connection

Required voltage

100 - 240 V ± 10% (autosensing)

Required frequency

50 - 60 Hz ± 3 Hz (autosensing)

Power consumption

- 65 W for typical analysis application
- 25 W standby (conductivity detector to 40 °C)

Power supply unit

- Up to 300 W maximum, electronically monitored
- internal fuse 3.15 A



7.4 Leak sensor

Type Electronic, no calibration necessary

7.5 Ambient conditions

Operation

Ambient temperature +5...+45 °C
Humidity 20...80 % relative humidity

Storage

Ambient temperature -20...+70 °C

Transport

Ambient temperature -40...+70 °C

7.6 Housing

Dimensions

Width 365 mm
Height 131 mm
Depth 380 mm

Material of housing

Operating elements

Indicators LED for standby operation
On/Off switch On the rear of the instrument

7.7 Interfaces

USB

Input 1 USB upstream, type B (for connection to the PC)

Output 2 USB downstream, type A

MSB 2 MSB Mini-DIN 8-pin (female) (for Dosino, stirrer, remote lines, ...)

Detector 2 DSUB-15-pin high density (female)

Cell recognition 1 on the front of the instrument

Leak sensor 1 jack plug

Further connections

- 1 DSUB 15-pin (female)

7.8 Safety specifications

This instrument fulfills the following electrical safety requirements:



CE designation in accordance with the EU directives:

- 2006/95/EC (Low Voltage Directive, LVD)
- 2004/108/EC (EMC Directive, EMC)

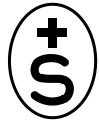

Federal Inspectorate for Heavy Current Installations ESTI (Accreditation Number SCESp 033)

- Safety mark for certification type 2 in accordance with NEV (type testing with market monitoring, EMC conformity)

Design and testing According to EN/IEC 61010-1, UL 61010-1, CSA-C22.2 No. 61010-1, degree of protection IP20, protection class I.

Safety instructions This document contains safety instructions which have to be followed by the user in order to ensure safe operation of the instrument.



7.9 Electromagnetic compatibility (EMC)

Emission

Standards fulfilled

- EN/IEC 61326-1
- EN/IEC 61000-6-3
- EN 55011 / CISPR 11
- EN/IEC 61000-3-2
- EN/IEC 61000-3-3

Immunity

Standards fulfilled

- EN/IEC 61326-1
- EN/IEC 61000-6-2
- EN/IEC 61000-4-2
- EN/IEC 61000-4-3
- EN/IEC 61000-4-4
- EN/IEC 61000-4-5
- EN/IEC 61000-4-6
- EN/IEC 61000-4-8
- EN/IEC 61000-4-11
- EN/IEC 61000-4-14
- EN/IEC 61000-4-28

8 Warranty (Guarantee)

Metrohm guarantees that the deliveries and services it provides are free of errors in materials, design or manufacturing.

The general warranty period is 36 months (exclusions below) from the date of delivery or 18 months in the event of continuous operation. The warranty remains valid on the condition that the servicing is provided by a Service Organization authorized by Metrohm at defined intervals and with a defined scope.

The warranty period for anion suppressors is 120 months from the date of delivery or 60 months in the event of continuous operation.

The warranty period for IC separation columns is 90 days after start-up.

For third-party components that are recognizable as such, the manufacturer's warranty regulations apply.

Consumables and materials with limited storage life and glass breakage in the case of electrodes or other glass parts are excluded from the warranty.

Warranty claims cannot be asserted if the customer has failed to meet his payment obligations according to schedule.

During the warranty period, Metrohm undertakes either to replace free of charge or to credit the purchaser for any assemblies or components that can be shown to be faulty. Any transport or customs fees that may apply are the ordering party's responsibility.

The precondition for this is that the ordering party must use the Return Material Authorization (RMA) to report the faulty part, along with specification of the article number, the article designation, an adequate error description, the delivery date and (if applicable) the serial number or the chip data, respectively. In addition, the ordering party undertakes to store the faulty part for at least 24 months in accordance with current storage directives (in compliance with ESD guidelines) and to hold it in readiness for onsite inspection or for return shipment to Metrohm. Metrohm reserves the right to invoice the ordering party for these articles, including retroactively, in the event of noncompliance with these pre-conditions.

The original warranty periods for the original part apply to parts that are replaced or repaired under the above-referenced warranties (no extension of the warranty period).

Deficiencies arising from circumstances that are not the responsibility of Metrohm, such as improper storage or improper use, etc., are expressly excluded from the warranty.



Metrohm also offers a 120-month spare parts availability guarantee and a 60-month PC software support warranty, calculated from the date on which the product is withdrawn from the market. The content of this warranty is the ability of the customer to obtain functioning spare parts or appropriate software support at market prices during the time of the warranty period.

If Metrohm AG is unable to meet this obligation due to circumstances beyond the control of Metrohm AG, then the ordering party shall be offered alternative solutions at preferential conditions.

9 Accessories



Note





Subject to change without notice.



9.1 Scope of delivery

2.896.0020 896 Professional Detector – Amperometry

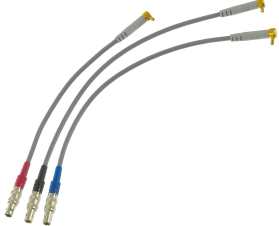
Qty.	Order no.	Description								
1	1.896.0020	<p>Professional Detector - Amp.</p> <p>Intelligent stand-alone detector equipped with the IC Amperometric Detector. With outstanding selectivity due to the four measuring modes: DC, PAD, flexIPAD and CV, as well as the excellent signal/noise ratio and very fast stabilization of the measuring signal guarantee highest precision of the measurement. For use with intelligent IC instruments or as independent detector.</p>								
1	6.2122.0x0	<p>Power supply cable with IEC 60320 line socket, type C13</p> <p>Cable plug according to customer requirements.</p> <table> <tr> <td>Switzerland:</td> <td>SEV 1011, Type 12 6.2122.020</td> </tr> <tr> <td>Germany, ...:</td> <td>CEE 7, Type VII 6.2122.040</td> </tr> <tr> <td>USA, ...:</td> <td>NEMA 5-15, Type 498 6.2122.070</td> </tr> <tr> <td>Length:</td> <td>1.5 m</td> </tr> </table>	Switzerland:	SEV 1011, Type 12 6.2122.020	Germany, ...:	CEE 7, Type VII 6.2122.040	USA, ...:	NEMA 5-15, Type 498 6.2122.070	Length:	1.5 m
Switzerland:	SEV 1011, Type 12 6.2122.020									
Germany, ...:	CEE 7, Type VII 6.2122.040									
USA, ...:	NEMA 5-15, Type 498 6.2122.070									
Length:	1.5 m									





Qty.	Order no.	Description	
1	6.1831.010	PEEK capillary 0.25 mm i.d. / 3 m	
		For all IC components.	
		Material: PEEK	
		Outer diameter (inches): 1/16	
		Inner diameter (mm): 0.25	
		Length (m): 3	
1	6.2151.020	Cable USB A - USB B 1.8 m	
		USB connecting cable Length (m): 1.8	
1	6.2165.000	Connecting cable to 61257XXX	
		Connecting cable for amperometric detector cell.	
1	6.2744.014	Pressure screw 2x	
		With UNF 10/32 connection. For the connection of PEEK capillaries	
		Material: PEEK	
		Length (mm): 26	





Qty.	Order no.	Description	
1	6.2813.040	Dummy cell to the IC Amperometric Detector. Dummy cell for performance tests.	
1	8.896.8005EN	Manual for 896 Professional Detector - Amperometry, 2.896.0020	

9.2 Optional accessories

2.896.0020 896 Professional Detector – Amperometry





Order no.	Description	
6.5333.000	IQ/OQ Kit for IC The IQ/OQ Kit contains all parts and standard solutions required for IQ/OQ in ion chromatography.	
6.5337.000	IC equipment Wall-Jet cell: without electrodes Wall-Jet cell without electrodes	

Order no.	Description	
6.5337.010	IC equipment Wall-Jet cell: Carb (Au, Pd) Wall-Jet cell for carbohydrate analysis with a gold working electrode and a Pd reference electrode.	
6.5337.020	IC equipment Wall-Jet cell: Cyanide (Ag, Pd) Wall-Jet cell for cyanide analysis with a silver working electrode and a Pd reference electrode.	
6.5337.030	IC equipment Wall-Jet cell: Anion (GC, Ag/AgCl). Wall-Jet cell for anion analysis with a Glassy Carbon and an Ag/AgCl reference electrode.	
6.1257.010	Wall-Jet Cell Amperometric detector cell with Wall-Jet geometry.	
6.1257.210	Au working electrode Gold working electrode for amperometric detection, 3 mm diameter.	

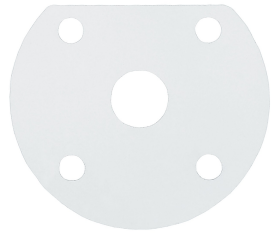
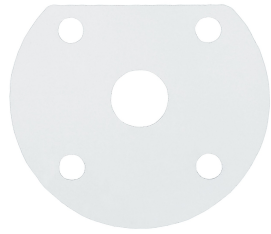
Order no.	Description	
6.1257.220	GC working electrode	 <p>A cylindrical, tan-colored electrode with a dark circular tip. The number 00396269 is printed on its side.</p>
6.1257.230	Pt working electrode	
Platinum working electrode for amperometric detection, 3 mm diameter.		
6.1257.240	Ag working electrode	 <p>Two tan-colored electrodes. One is a small cylindrical electrode with a white tip. The other is a larger cylindrical electrode with a gold-colored tip and the number 6.1257.240 and the letter Ag printed on its side.</p>
6.1257.260	Au working electrode	 <p>A cylindrical, tan-colored electrode with a yellow circular tip. The number 00395311 is printed on its side.</p>
6.1257.720	Ag/AgCl reference electrode for 6.1257.xxx	
Silver/silver chloride reference electrode for amperometric detection.		
6.1257.740	Pd reference electrode to 6.1257.xxx	 <p>A tan-colored electrode with a black ring at the bottom. The number 00395576 is printed on its side.</p>



Order no.	Description
6.1257.810	Spacer 50 µm to Wall-Jet Cell
	Spacer 50 µm for the amperometric Wall-Jet Cell. 
6.1257.830	Spacer 25 µm to Wall-Jet Cell
	Spacer 25 µm for the amperometric Wall-Jet Cell. 
6.5866.020	Upgrade 896: Conductometric Detector
8.896.3001	Declaration of conformity for 896 Professional Detector
8.896.5000	Brochure: 896 Professional Detector / 850 IC Amperometric Detector - Amperometric detection for determining electroactive components
	<p>This new amperometric detector complements Metrohm's portfolio of intelligent ion chromatography instruments as an alternative to conductivity and UV/VIS detectors. It may be used when electroactive - i.e. oxidizable or reducible - components are to be determined. The highlights at a glance: Flexible setup as stand-alone detector or detector block for IC and HPLC Outstanding selectivity due to different measuring modes: DC, PAD, flexIPAD, CV High sensitivity through excellent signal/noise ratio Large measuring range for demanding applications Easy to use due to intelligent and robust measuring cells with wall-jet and thin-layer design Large variety of working electrodes: Au, Ag, Pt, GC Different maintenance-free reference electrodes Very fast start-up without long conditioning times Leak sensor in the cell compartment Fully compliant with Metrohm Inline Sample Preparation techniques Control and monitoring by MagIC Net™ - the proven software for ion chromatography</p>
8.850.5007	Brochure: Intelligent Ion Chromatography - 850 Professional IC, 872 Extension Module, 858 Professional Sample Processor
	<p>Highlights: Highly compact modular system MagIC Net™ software for intuitive and simple operation Comprehensive monitoring and control functions Complies with GLP and FDA requirements Flexible assembly and extension: from isocratic cation system up to quaternary high pressure gradient system Combined third-</p>

Order no.	Description	
	<p>generation anion-cation systemsMISP – Metrohm Inline Sample Preparation – patented and unique sample preparationIntelligent system components: iPump, iDetector, iColumn, intelligent Dosing UnitsProfessional Sample Processor for any required volumes and extensive liquid handling operationsHigh-precision Dosino technologyHardware from the technology leaderSwiss Engineered – Swiss Made</p>	
6.6059.241	MagIC Net™ 2.4 Compact CD: 1 license	
	<p>Professional PC program for controlling an intelligent Compact IC system, a detector and an Autosampler, or a 771 Compact Interface. The software permits control, data acquisition, evaluation and monitoring, as well as report generation of ion chromatographic analyses. Graphics user interface for routine operations, extensive database programs, method development, configuration and manual system control; very flexible user administration, efficient database operations, extensive data export functions, individually configurable report generator, control and monitoring of all system components and chromatography results. MagIC Net™ Compact complies fully with FDA Regulation 21 CFR Part 11 as well as GLP. Dialog languages: German, English, French, Spanish, Chinese, Korean, Japanese, et. al. 1 license.</p>	
6.6059.242	MagIC Net 2.4™ Professional CD 1 license	
	<p>Professional PC program for controlling intelligent Professional IC systems, Compact IC systems and their peripherals such as various Autosamplers, 800 Dosino, 771 Compact Interface, etc. The software permits control, data acquisition, evaluation and monitoring as well as report generation of ion chromatographic analyses. Graphics user interface for routine operations, extensive database programs, method development, configuration and manual system control; very flexible user administration, efficient database operations, extensive data export functions, individually configurable report generator, control and monitoring of all system components and the chromatography results. MagIC Net™ Professional complies fully with FDA Regulation 21 CFR Part 11 as well as GLP. Dialog languages: German, English, French, Spanish, Chinese, Korean, Japanese, et. al. 1 license.</p>	
6.6059.243	MagIC Net 2.4™ Multi CD: 3 licenses	
	<p>Professional PC program for controlling intelligent Professional IC systems, Compact IC systems and their peripherals, such as various Autosamplers, 800 Dosino, 771 Compact Interface, etc. The software permits control, data acquisition, evaluation and monitoring as well as report generation of ion chromatographic analyses. Graphics user interface for routine operations, extensive database programs, method development, configuration and manual system control; very flexible user administration, efficient database operations, extensive data export functions, individually configurable report generator, control and monitoring of all system components and chromatography results. MagIC Net™ Multi complies fully with FDA Regulation 21 CFR Part 11 as well as GLP. Dialog languages: German, English, French, Spanish, Chinese, Korean, Japanese, et. al. Client-Server version with 3 licenses.</p>	



Index

A

Ambient conditions	42
Amperometric detector	
Installation	15
Maintenance	29
Start-up	15
Technical specifications	40

B

Base tray	
Mount	11
Remove	10
Bottle holder	
Mount	13
Remove	12

C

Cell recognition	43
Connection	
Power	41

D

Detector	
Interface	43

E

Electrostatic charge	3
----------------------------	---

F

Frequency	41
-----------------	----

G

GLP	30
Guarantee	45

H

Humidity	42
----------------	----

I

Installation	
Amperometric detector	15
Instrument	
Connect	15
Interface	
MSB	43
USB	43
Interfaces	43
Further connections	43
Leak sensor	43

L

Leak sensor	
Interface	43
Technical data	42

M

Mains connection	15, 16
Mains voltage	3
Maintenance	
Amperometric detector	29
MSB	43

P

PC connection	15
Power connection	41
Power consumption	41
Power supply cable	15
Power supply unit	41

Q

Quality Management	30
--------------------------	----

R

Reference conditions	40
----------------------------	----

Regeneration	28
Rinsing	
Detector	29

S

Safety instructions	2
Service	2, 28
Service Agreement	30
Shutting down	29
Start-up	
Amperometric detector	15
Storage	42
Switch on	16

T

Technical data	
Leak sensor	42
Reference conditions	40
Technical specifications	
Amperometric detector	40
Detector	43
Interfaces	43
Temperature	42
Transport	42

U

USB	43
-----------	----

V

Validation	30
Voltage	41

W

Warranty	45
----------------	----