

# 882 Compact IC plus



882 Compact IC plus – Anion – MCS

Manual  
8.882.8013EN





Metrohm AG  
CH-9100 Herisau  
Switzerland  
Phone +41 71 353 85 85  
Fax +41 71 353 89 01  
info@metrohm.com  
www.metrohm.com

# **882 Compact IC plus**

## **882 Compact IC plus – Anion – MCS**

2.882.0030

# **Manual**

Teachware  
Metrohm AG  
CH-9100 Herisau  
teachware@metrohm.com

This documentation is protected by copyright. All rights reserved.

Although all the information given in this documentation has been checked with great care, errors cannot be entirely excluded. Should you notice any mistakes please send us your comments using the address given above.

Documentation in additional languages can be found on <http://products.metrohm.com> under **Literature/Technical documentation**.

# Table of contents

<b>1</b>	<b>Introduction</b>	<b>1</b>
1.1	Instrument description	1
1.2	About the documentation	2
1.2.1	Symbols and conventions	3
1.3	Intended use	4
1.4	Safety instructions	4
1.4.1	General notes on safety	4
1.4.2	Electrical safety	4
1.4.3	Tubing and capillary connections	6
1.4.4	Flammable solvents and chemicals	6
1.4.5	Recycling and disposal	6
<b>2</b>	<b>Overview of the instrument</b>	<b>7</b>
2.1	Front	7
2.2	Rear	8
<b>3</b>	<b>Installation</b>	<b>10</b>
3.1	About this chapter	10
3.2	Initial installation	10
3.3	Installation diagram	14
3.4	Setting up the instrument	17
3.4.1	Packaging	17
3.4.2	Checks	17
3.4.3	Location	17
3.5	Capillary connections in the IC system	17
3.6	Installations on the rear of the instrument	20
3.6.1	Transport locking screws	20
3.6.2	Leak sensor	20
3.6.3	Drainage tubings	21
3.7	Capillary and cable feed-throughs	23
3.8	Eluent	25
3.8.1	Connecting eluent bottle	25
3.9	High pressure pump	29
3.9.1	Capillary connections high pressure pump/purge valve	29
3.9.2	Deaerating the high pressure pump	32
3.10	Inline filter	34
3.11	Pulsation absorber	35



<b>3.12</b>	<b>Injection valve</b> .....	<b>36</b>
3.12.1	Connecting the injection valve .....	36
3.12.2	Mode of operation of the injection valve .....	38
3.12.3	Selecting the sample loop .....	39
<b>3.13</b>	<b>Peristaltic pump</b> .....	<b>39</b>
3.13.1	Principle of the peristaltic pump .....	39
3.13.2	Installing the peristaltic pump .....	41
<b>3.14</b>	<b>Metrohm Suppressor Module (MSM)</b> .....	<b>45</b>
3.14.1	Connecting the suppressor .....	45
<b>3.15</b>	<b>Metrohm CO<sub>2</sub> Suppressor (MCS)</b> .....	<b>48</b>
3.15.1	General information on the MCS .....	48
3.15.2	Connecting MCS .....	48
3.15.3	Installing the adsorption cartridges .....	50
<b>3.16</b>	<b>Connecting the instrument</b> .....	<b>52</b>
3.16.1	Connecting the instrument to the PC .....	52
3.16.2	Connecting the instrument to mains supply .....	52
<b>3.17</b>	<b>Guard column</b> .....	<b>53</b>
<b>3.18</b>	<b>Separation column</b> .....	<b>54</b>
<b>4</b>	<b>Start-up</b> .....	<b>57</b>
4.1	Initial start-up .....	57
4.2	Conditioning .....	58
<b>5</b>	<b>Operation and maintenance</b> .....	<b>60</b>
5.1	General notes .....	60
5.1.1	Care .....	60
5.1.2	Maintenance by Metrohm Service .....	60
5.1.3	Operation .....	61
5.1.4	Shutting down .....	61
5.2	Capillary connections .....	61
5.2.1	Operation .....	61
5.3	Door .....	62
5.4	Eluent .....	62
5.4.1	Production .....	62
5.4.2	Operation .....	63
5.5	High pressure pump .....	63
5.5.1	Protection .....	63
5.5.2	Maintenance .....	64
5.6	Inline filter .....	74
5.6.1	Maintenance .....	74
5.7	Injection valve .....	76
5.7.1	Protection .....	76

<b>5.8</b>	<b>Inline sample preparation</b>	<b>76</b>
<b>5.9</b>	<b>Rinsing the sample path</b>	<b>76</b>
<b>5.10</b>	<b>Peristaltic pump</b>	<b>78</b>
5.10.1	Operation	78
5.10.2	Maintenance	78
<b>5.11</b>	<b>Metrohm Suppressor Module (MSM)</b>	<b>80</b>
5.11.1	Protection	80
5.11.2	Operation Suppressor	81
5.11.3	Maintenance	82
<b>5.12</b>	<b>Metrohm CO<sub>2</sub> Suppressor (MCS)</b>	<b>87</b>
5.12.1	Replacing the CO <sub>2</sub> adsorption cartridge	87
5.12.2	Regenerating the H <sub>2</sub> O adsorption cartridge	87
<b>5.13</b>	<b>Separation column</b>	<b>88</b>
5.13.1	Separating efficiency	88
5.13.2	Protection	88
5.13.3	Storage	89
5.13.4	Regeneration	89
<b>5.14</b>	<b>Quality Management and validation with Metrohm</b>	<b>89</b>
<b>6</b>	<b>Troubleshooting</b>	<b>91</b>
6.1	Problems and their solutions	91
<b>7</b>	<b>Technical specifications</b>	<b>95</b>
7.1	Reference conditions	95
7.2	Instrument	95
7.3	Leak sensor	95
7.4	Ambient conditions	95
7.5	Housing	96
7.6	High pressure pump	96
7.7	Injection valve	97
7.8	Peristaltic pump	97
7.9	Metrohm Suppressor Module (MSM)	97
7.10	Metrohm CO <sub>2</sub> Suppressor (MCS)	98
7.11	Mains connection	98
7.12	Interfaces	98
7.13	Safety specification	99
7.14	Electromagnetic compatibility (EMC)	99
7.15	Weight	100



<b>8</b>	<b>Conformity and warranty</b>	<b>101</b>
8.1	Declaration of Conformity .....	101
8.2	Quality Management Principles .....	102
8.3	Warranty (guarantee) .....	103
<b>9</b>	<b>Accessories</b>	<b>105</b>
9.1	Scope of delivery .....	105
9.2	Optional accessories .....	115
	<b>Index</b>	<b>118</b>

## Table of figures

Figure 1	Front 882 Compact IC plus – Anion – MCS .....	7
Figure 2	Rear 882 Compact IC plus – Anion – MCS .....	8
Figure 3	Installation diagram 882 Compact IC plus – Anion – MCS .....	15
Figure 4	Connection of capillaries with pressure screws .....	18
Figure 5	leak sensor – plugging in .....	21
Figure 6	Drainage tubings .....	22
Figure 7	Capillary and cable feed-throughs .....	24
Figure 8	Installing eluent bottle attachment .....	26
Figure 9	Mounting aspiration filter .....	26
Figure 10	Install tubing weighting and aspiration filter .....	27
Figure 11	Eluent aspiration tubing fully equipped. ....	27
Figure 12	Eluent bottle – connected .....	28
Figure 13	Capillary connections high pressure pump/purge valve .....	30
Figure 14	High pressure pump – Connect inlet .....	31
Figure 15	Deaerate the high pressure pump .....	33
Figure 16	Connecting the inline filter .....	35
Figure 17	Pulsation absorber – Connection .....	36
Figure 18	Injection valve – connected .....	37
Figure 19	Injection valve – Positions .....	38
Figure 20	Peristaltic pump .....	40
Figure 21	Installing the pump tubing .....	41
Figure 22	Install pump tubing connection with filter .....	42
Figure 23	Install pump tubing connection without filter .....	43
Figure 24	Suppressor – connection capillaries .....	46
Figure 25	MCS – connection .....	49
Figure 26	Adsorption cartridge holder .....	50
Figure 27	Pump head – removing the piston .....	65
Figure 28	Components of the piston cartridge .....	66
Figure 29	Tool for piston seal .....	67
Figure 30	Removing the piston seal .....	68
Figure 31	Inserting the piston seal into the tool .....	68
Figure 32	Inserting the piston seal into the pump head .....	69
Figure 33	Removing valves .....	70
Figure 34	Dismantling valve .....	71
Figure 35	Components of the inlet valve and outlet valve .....	72
Figure 36	Change filters (of the inline filter) .....	74
Figure 37	Pump tubing connection – Changing the filter .....	80
Figure 38	Parts of the suppressor .....	82



# 1 Introduction

## 1.1 Instrument description

The instrument **882 Compact IC plus – Anion – MCS** is one of the model versions of the 882 Compact IC plus line of instruments manufactured by the Metrohm Company. The 882 Compact IC plus line of instruments is distinguished by:

- the **intelligence** of its components, which are able to monitor and optimize all functions and to provide documentation according to FDA requirements.
- its **compact style of construction**.
- its **transparency**. All components are easily accessible and arranged in a clear manner.
- its **safety**. Chemicals and electronics are separated and a leak sensor is integrated in the wet end.
- its **environmental compatibility**.
- its **low noise emission**.

The instrument is operated with **MagIC Net™** software. It is connected via a USB connection to a PC on which MagIC Net™ is installed. The software automatically recognizes the instrument and checks its functional readiness. MagIC Net™ controls and monitors the instrument, evaluates the measured data and administers it in a database. The operation of MagIC Net™ is described in the online help or in the tutorial for MagIC Net™.

The instrument contains the following components:

### High pressure pump

The intelligent and low pulsation high pressure pump pumps the eluent through the system. It is equipped with a chip on which its technical specifications and "life history" (operating hours, service data, ...) are saved.

### Inline filter

Inline filters protect the separation column securely against possible contamination from the eluent. Inline filters can however also just as well be used for the purpose of protecting other sensitive components against contaminations in the solutions used. The filter platelets with a pore size of 2 µm can be replaced quickly and easily. They remove particles like e. g. bacteria and algae from the solutions.

**Pulsation absorber**

The pulsation absorber protects the separation column from damage caused by pressure fluctuations when switching the injection valve, and reduces interfering pulsations during highly sensitive measurements.

**Injection valve**

The injection valve connects the eluent and sample path through rapid and precise valve switchover. A precisely measured amount of sample solution is injected and rinsed with eluent onto the separation column.

**Peristaltic pump**

The Peristaltic pump is used for pumping sample and auxiliary solutions. It can rotate in both directions.

**Metrohm Suppressor Module (MSM)**

The MSM is used for chemical suppression in anion analysis with conductivity detection or UV detection. It is pressure-stable, robust and resistant to solvents.

**Metrohm CO<sub>2</sub> Suppressor (MCS)**

The Metrohm CO<sub>2</sub> Suppressor (MCS) removes the CO<sub>2</sub> from the eluent flow. This reduces the background conductivity, improves the detection sensitivity and minimizes the injection and carbonate peaks.

**Separation column**

The intelligent separation column is the heart of the ion chromatographic analysis. It separates the different components corresponding to their interactions with the column. Metrohm separation columns are equipped with a chip on which their technical specifications and their history (first use / setting up, operating hours, injections, ...) are saved.







## 1.2 About the documentation

**Caution**

Please read through this documentation carefully before putting the instrument into operation. The documentation contains information and warnings which the user must follow in order to ensure safe operation of the instrument.

### 1.2.1 Symbols and conventions

The following symbols and styles are used in this documentation:

(5-12)	<p><b>Cross-reference to figure legend</b></p> <p>The first number refers to the figure number, the second to the instrument part in the figure.</p>
1	<p><b>Instruction step</b></p> <p>Carry out these steps in the sequence shown.</p>
	<p><b>Warning</b></p> <p>This symbol draws attention to a possible life hazard or risk of injury.</p>
	<p><b>Warning</b></p> <p>This symbol draws attention to a possible hazard due to electrical current.</p>
	<p><b>Warning</b></p> <p>This symbol draws attention to a possible hazard due to heat or hot instrument parts.</p>
	<p><b>Warning</b></p> <p>This symbol draws attention to a possible biological hazard.</p>
	<p><b>Caution</b></p> <p>This symbol draws attention to a possible damage of instruments or instrument parts.</p>
	<p><b>Note</b></p> <p>This symbol marks additional information and tips.</p>



**Warning**

---

Only personnel qualified by Metrohm are authorized to carry out service work on electronic components.

**Warning**

---

Never open the housing of the instrument. The instrument could be damaged by this. There is also a risk of serious injury if live components are touched.

There are no parts inside the housing which can be serviced or replaced by the user.

**Mains voltage****Warning**

---

An incorrect mains voltage can damage the instrument.

Only operate this instrument with a mains voltage specified for it (see rear panel of the instrument).

**Protection against electrostatic charges****Warning**

---

Electronic components are sensitive to electrostatic charges and can be destroyed by discharges.

Always pull the mains cable out of the mains connection socket before connecting or disconnecting electrical appliances on the rear panel of the instrument.



### 1.4.3 Tubing and capillary connections



#### Caution

Leaks in tubing and capillary connections are a safety risk. Tighten all connections well by hand. Avoid applying excessive force to tubing connections. Damaged tubing ends lead to leakage. Appropriate tools can be used to loosen connections.

Check the connections regularly for leakage. If the instrument is used mainly in unattended operation, then weekly inspections are mandatory.

### 1.4.4 Flammable solvents and chemicals



#### Warning

All relevant safety measures are to be observed when working with flammable solvents and chemicals.

- Set up the instrument in a well-ventilated location (e.g. laboratory flue).
- Keep all sources of flame far from the workplace.
- Clean up spilled fluids and solids immediately.
- Follow the safety instructions of the chemical manufacturer.

### 1.4.5 Recycling and disposal

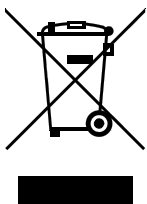

This product is covered by European Directive 2002/96/EC, WEEE – Waste from Electrical and Electronic Equipment.

The correct disposal of your old equipment will help to prevent negative effects on the environment and public health.

More details about the disposal of your old equipment can be obtained from your local authorities, from waste disposal companies or from your local dealer.

## 2 Overview of the instrument

### 2.1 Front

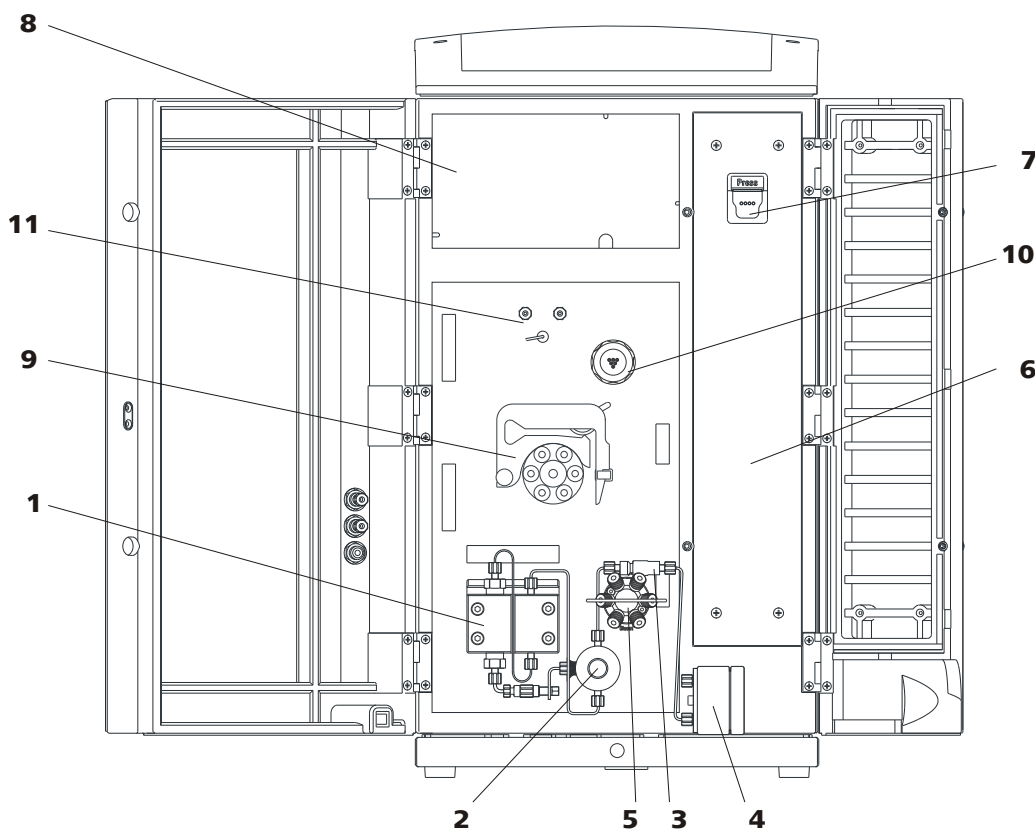

Figure 1 Front 882 Compact IC plus – Anion – MCS

<b>1</b>	<b>High pressure pump</b>	<b>2</b>	<b>Purge valve</b>
<b>3</b>	<b>Inline filter</b>	<b>4</b>	<b>Pulsation absorber</b>
<b>5</b>	<b>Injection valve</b>	<b>6</b>	<b>Column chamber</b>
<b>7</b>	<b>Column holder</b> With column recognition.	<b>8</b>	<b>Detector chamber</b> Room for the detector and the adsorption cartridges for the MCS.
<b>9</b>	<b>Peristaltic pump</b>	<b>10</b>	<b>Metrohm Suppressor Module (MSM)</b>
<b>11</b>	<b>Metrohm CO<sub>2</sub> Suppressor (MCS)</b>		

## 2.2 Rear

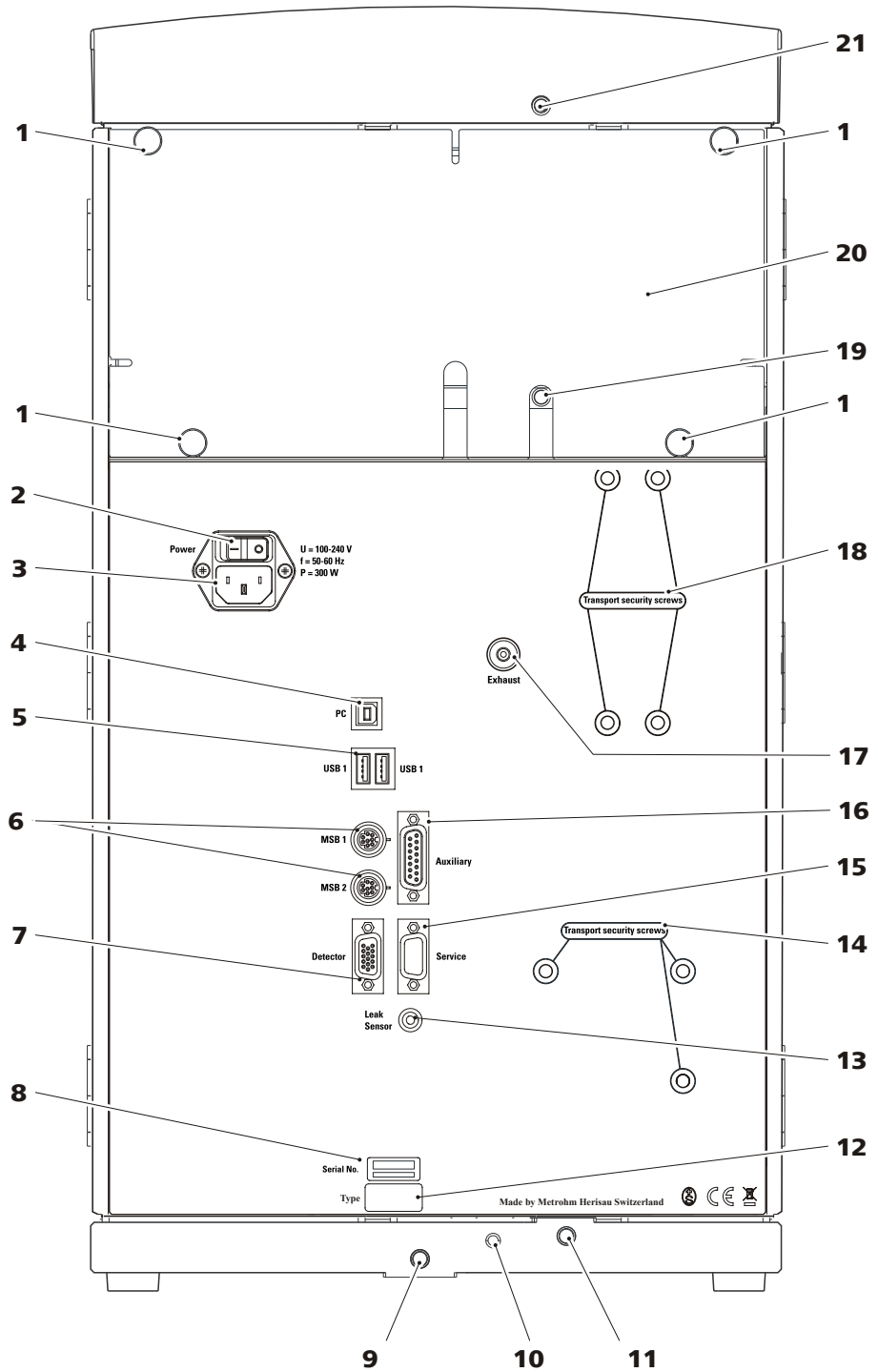

Figure 2 Rear 882 Compact IC plus – Anion – MCS

**1 Knurled screws**  
For fastening the removable rear panel.

**2 Mains switch**  
For switching the instrument on and off.

	I = On O = Off
<b>3 Mains connection socket</b> For connecting the mains cable.	<b>4 PC connection socket</b> For connecting the instrument to the computer with the USB cable (6.2151.020).
<b>5 USB connectors</b> 2 USB connectors labeled with <b>USB 1</b> and <b>USB 2</b> .	<b>6 MSB connectors</b> 2 MSB connectors for connecting MSB devices. Labeled with <b>MSB 1</b> and <b>MSB 2</b> . MSB = Metrohm Serial Bus
<b>7 Detector connection socket</b> For connecting Metrohm detectors. Labeled with <b>Detector</b> .	<b>8 Serial number</b>
<b>9 Drainage tubing connector</b> For draining the escaped liquid from the base tray through the connected drainage tubing.	<b>10 Leak sensor connection cable</b> Extractable. For connecting the leak sensor.
<b>11 Drainage tubing connector</b> For supplying escaped liquid through the connected drainage tubing to the leak sensor.	<b>12 Device type</b>
<b>13 Leak sensor connection socket</b> For connecting the leak sensor.	<b>14 Transport locking screws</b> For securing the high pressure pump when transporting the instrument.
<b>15 Service connection socket</b> For Metrohm service only.	<b>16 Auxiliary connection socket</b> For connecting a 891 Professional Analog out (2.891.0010).
<b>17 Exhaust air opening</b> For extracting the air from the vacuum chamber. Labeled with <b>Exhaust</b> .	<b>18 Transport locking screws</b> Not Used.
<b>19 Drainage tubing connector</b> For draining escaped liquid from the detector chamber through a connected drainage tubing.	<b>20 Rear panel</b> Removable. Access to the detector chamber.
<b>21 Drainage tubing connector</b> For draining escaped liquid from the flask holder through a connected drainage tubing.	



## 3 Installation

### 3.1 About this chapter

The Installation chapter contains:

- this overview.
- a brief set of instructions for the initial installation of the 882 Compact IC plus – Anion – MCS. At each step you will find cross-references to more detailed installation instructions for the individual components, should you require such aids.
- an installation diagram (see *Figure 3, page 15*), showing a completely installed 882 Compact IC plus – Anion – MCS.
- several chapters (*Chapter 3.4, page 17 and following*) with detailed installation instructions for all components, including those that are already installed at the time the instrument is delivered.

### 3.2 Initial installation



#### Note

A number of the capillaries is already connected at the time the instrument is delivered.

#### Installing 882 Compact IC plus – Anion – MCS

Install the instrument as follows:

##### 1 Setting up the instrument

(see *Chapter 3.4, page 17*).

- Place the instrument in a location of the laboratory which is suitable for operation and free of vibrations.  
The installation site must be protected against corrosive atmosphere and contamination by chemicals. If possible, avoid excessive temperature fluctuations and direct sunlight.

##### 2 Installations on the rear of the instrument

- Place the detector in the instrument and connect it (see *manual of the detector*).
- Remove transport locking screws (see *Chapter 3.6.1, page 20*).

- Connect the leak sensor (*see Chapter 3.6.2, page 20*).
- Connect the drainage tubings (*see Chapter 3.6.3, page 21*).

### 3 Connecting the eluent path

- Lead the eluent aspiration tubing (6.1834.080) out of the instrument through a capillary feed-through and connect it with the eluent bottle (*see Chapter 3.8, page 25*).
- Connect the column inlet capillary (6.1831.150) and the capillary of the MSM labeled with **in** to one another using a coupling (6.2744.040) and two short pressure screws (6.2744.070).
- Use a long pressure screw (6.2744.090) to connect the capillary of the MSM labeled with **out** to the input of the of the MCS (*see "Connecting the MCS", page 49*).
- Connect the detector inlet capillary with a long pressure screw (6.2744.090) to the output of the MCS (*see "Connecting the MCS", page 49*).

### 4 Connecting the sample path

- Guide the sample aspiration capillary connected to the sample input of the injection valve out of the instrument through a capillary feed-through and connect it with the Sample Processor, if applicable (*see Sample Processor manual*).
- Guide the sample outlet capillary connected to the sample output of the injection valve out of the instrument through a capillary feed-through and onward to the waste container and then fasten it there.

### 5 Installing the peristaltic pump

(*see Chapter 3.13.2, page 41*)

- Prepare the pump tubing for the regeneration solution:
  - Plug a tubing olive (6.2744.034) onto one end of the pump tubing (6.1826.320).
  - Plug a pump tubing connection (6.2744.180) onto the other end of the pump tubing.
  - Connect one end of the aspirating capillary (6.1803.020) for the regeneration solution to the tubing olive on the pump tubing using a short pressure screw (6.2744.070).
  - Guide the other end of the aspirating capillary out of the instrument through a capillary feed-through, slide it through a bottle attachment (6.1602.150) and screw the bottle attachment onto the bottle (6.1608.020) containing the regeneration solution. Ensure that the end of the aspirating capillary reaches down to the bottom of the bottle.
  - Place the pump tubing into a tubing cartridge.



- Prepare a pump tubing for the rinsing solution:
  - Plug a tubing olive (6.2744.034) onto one end of the pump tubing (6.1826.320).
  - Plug a pump tubing connection (6.2744.180) onto the other end of the pump tubing.
  - Connect one end of the aspirating capillary (6.1803.020) for the rinsing solution to the tubing olive on the pump tubing using a short pressure screw (6.2744.070).
  - Guide the other end of the aspirating capillary out of the instrument through a capillary feed-through, slide it through a bottle attachment (6.1602.150) and screw the bottle attachment onto the bottle (6.1608.020) containing the rinsing solution. Ensure that the end of the aspirating capillary reaches down to the bottom of the bottle.
  - Place the pump tubing into the other tubing cartridge.
- Place both tubing cartridges into the peristaltic pump.

## 6 Connecting the MSM

*(see Chapter 3.14, page 45)*

- Connect the capillary of the MSM labeled with **regenerant** to the pump tubing connection of the pump tubing for the regeneration solution using a short pressure screw (6.2744.070).
- Connect the capillary of the MSM labeled with **rinsing solution** to the pump tubing connection of the pump tubing for the rinsing solution using a short pressure screw (6.2744.070).
- Guide the two capillaries of the MSM labeled with **waste reg.** and **waste rins.** out of the instrument through a capillary feed through to a waste container and fasten them there.

## 7 Connecting the MCS

*(see Chapter 3.15, page 48)*

- Attach the CO<sub>2</sub> adsorption cartridge (6.2837.000) to the adsorption cartridge holder (6.2057.080) (*see "Installing the adsorption cartridges", page 51*).
- Prepare the H<sub>2</sub>O adsorption cartridge (6.2837.010) (*see leaflet to the H<sub>2</sub>O adsorption cartridge*) and attach it to the adsorption cartridge holder as well (*see Figure 26, page 50*).
- Plug the adapter (6.1808.190) onto the PVC tubing and connect the two adsorption cartridges with one another (*see Figure 26, page 50*).
- Place the adsorption cartridge holder (6.2057.080) in the detector chamber.
- Connect the MCS air aspirating capillary to the tip of the CO<sub>2</sub> adsorption cartridge (6.2837.000).

## 8 Connecting the instrument

- Connect the instrument to a computer on which the software MagIC Net™ is installed using the USB cable (6.2151.020) (see Chapter 3.16.1, page 52).
- Connect the instrument to the mains supply (see Chapter 3.16.2, page 52).

## 9 Initial start-up

(see Chapter 4.1, page 57)

- Switch on the PC and start the software MagIC Net™.
- Switch on the instrument.
- Deaerate the high pressure pump (see Chapter 3.9.2, page 32).
- Set contact pressure of the peristaltic pump (see "Set flow rate", page 44).
- Rinse the instrument without column with eluent for 5 minutes.

## 10 Installing guard and separation column

- Remove the coupling (6.2744.040) between the column inlet capillary and the capillary of the MSM labeled with **in**.
- *Optional* Connect guard column (see Chapter 3.17, page 53)
  - Fasten the guard column to the end of the column inlet capillary (see leaflet to the guard column).
  - Rinse the guard column with eluent for approx. 5 minutes.
- Connect the separation column (see Chapter 3.18, page 54)
  - Connect the inlet of the separation column either with the end of the column input capillary using a short pressure screw (6.2744.070).  
OR  
Connect the inlet of the separation column with the guard column (if used) (see leaflets to the separation column and the guard column)
  - Connect the MSM capillary labeled with **in** with the output of the separation column using a short pressure screw (6.2744.070).
- Hang separation column with chip in the column holder of the instrument.

## 11 Conditioning the instrument

(see Chapter 4.2, page 58)

The instrument is now ready for measuring samples.



### **3.3 Installation diagram**

The following installation diagram shows the schematics of the front of the instrument after installation is complete. Many capillaries are already installed at the time the instrument is delivered; these capillaries are not numbered in the diagram. Numbered capillaries must be connected at the time of installation.

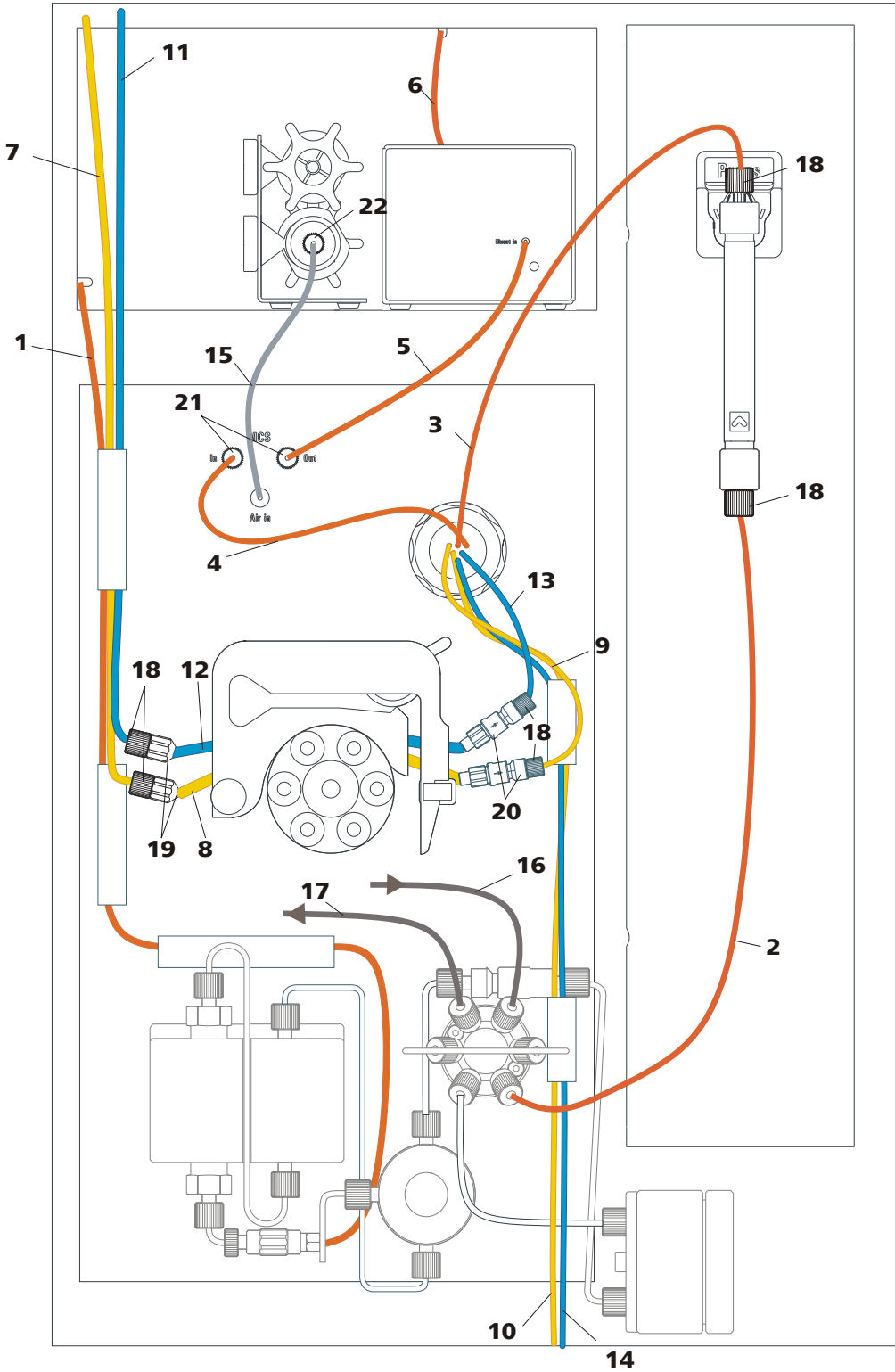

Figure 3 Installation diagram 882 Compact IC plus – Anion – MCS

**1 Eluent aspiration tube (6.1834.080)**  
Connected to the high pressure pump.

**2 Column input capillary (6.1831.150)**  
Connected to the injection valve.



<b>3 MSM eluent input capillary</b> Labeled with <b>in</b> .	<b>4 MSM eluent output capillary</b> Labeled with <b>out</b> .
<b>5 Detector input capillary</b> Mounted on the front of the detector.	<b>6 Detector output capillary</b> Mounted on the rear of the detector.
<b>7 Regeneration solution aspiration capillary (6.1803.020)</b>	<b>8 Pump tubing (6.1826.320)</b> With orange/yellow stoppers, for the regeneration solution.
<b>9 MSM regeneration solution input capillary</b> Labeled with <b>regenerant</b> .	<b>10 MSM regeneration solution output capillary</b> Labeled with <b>waste reg.</b>
<b>11 Rinsing solution aspiration capillary (6.1803.020)</b>	<b>12 Pump tubing (6.1826.320)</b> With orange/yellow stoppers, for the rinsing solution.
<b>13 MSM rinsing solution input capillary</b> Labeled with <b>rinsing solution</b> .	<b>14 MSM rinsing solution output capillary</b> Labeled with <b>Waste rins.</b>
<b>15 MCS aspirating capillary</b> For aspirating air low in CO <sub>2</sub> out of the CO <sub>2</sub> adsorption cartridge.	<b>16 Sample aspiration capillary (6.1803.040)</b> Connected to the injection valve.
<b>17 Sample output capillary (6.1803.040)</b> Connected to the injection valve.	<b>18 PEEK pressure screw, short (6.2744.070)</b>
<b>19 Tubing olive (6.2744.034)</b> For connecting capillaries to the aspiration side of the peristaltic pump.	<b>20 Pump tube connection (6.2744.180)</b> With safety device and filter, for connecting capillaries to the outlet side of the peristaltic pump.
<b>21 PEEK pressure screw, long (6.2744.090)</b>	<b>22 Luer coupling (6.2744.120)</b> Mounted to the MCS with a short pressure screw (6.2744.070) (3- <b>15</b> ) and connected to the CO <sub>2</sub> adsorption cartridge.

## **3.4 Setting up the instrument**

### **3.4.1 Packaging**

The instrument is supplied in highly protective special packaging together with the separately packed accessories. Keep this packaging, as only this ensures safe transportation of the instrument.

### **3.4.2 Checks**

Immediately after receipt, check whether the shipment has arrived complete and without damage by comparing it with the delivery note.

### **3.4.3 Location**

The instrument has been developed for operation indoors and may not be used in explosive environments.

Place the instrument in a location of the laboratory which is suitable for operation, free of vibrations, protected from corrosive atmosphere, and contamination by chemicals.

The instrument should be protected against excessive temperature fluctuations and direct sunlight.

## **3.5 Capillary connections in the IC system**

This chapter contains general information concerning the capillary connections in the IC instruments and systems.

Generally speaking, capillary connections between two components of an IC system are made up of one connection capillary and two pressure screws with which the capillary is connected to the respective components.

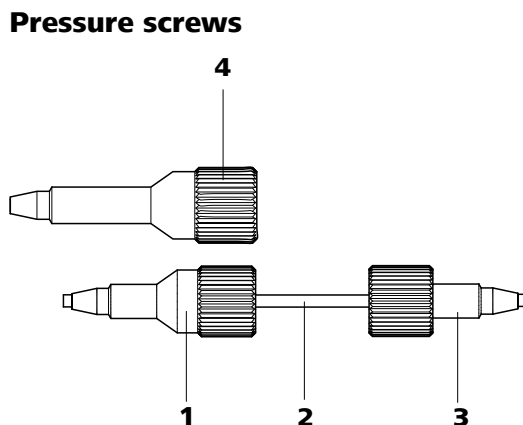

Figure 4 Connection of capillaries with pressure screws

<p><b>1 PEEK pressure screw (6.2744.014)</b> Use on the injection valve.</p>	<p><b>2 Connection capillary</b></p>
<p><b>3 PEEK pressure screw, short (6.2744.070)</b> For use on the high pressure pump, the purge valve, the inline filter, the pulsation absorber, the guard column and the separation column.</p>	<p><b>4 PEEK pressure screw, long (6.2744.090)</b> Use on special components. Is not used on all instruments.</p>



**Note**

In order to keep the dead volume as low as possible, capillary connections should generally be as short as possible.



**Note**

For an improved overview, capillary and tubing connections can be bundled with the 6.1815.010 spiral band.

**Connection capillaries**

PEEK capillaries and PTFE capillaries are used in the IC system.

*PEEK capillaries (polyetheretherketone)*

PEEK capillaries are temperature-resistant up to 100°C, stable under pressure up to 400 bar, flexible, chemically inert and exhibit an extremely smooth surface. They can be readily cut down to the desired length with the 6.2621.080 capillary cutter.

Usage:

- PEEK capillaries (6.1831.010) with an internal diameter of 0.25 mm for the entire high pressure range.

- PEEK capillaries (6.1831.030) with an internal diameter of 0.75 mm for sample handling in the ultra trace range.



### Caution

For the capillary connections between the injection valve and detector, PEEK capillaries with an internal diameter of 0.25 mm must be used. These are already connected to a newly delivered instrument.

*PTFE capillaries (poly-tetrafluoroethylene)*

PTFE capillaries are transparent and enable visual tracing of the liquids to be pumped. They are chemically inert, flexible and temperature-resistant up to 80°C.

Usage:

PTFE capillaries (6.1803.0x0) are used for the low pressure range.

- PTFE capillaries with internal diameter of 0.5 mm for sample handling.
- PTFE capillaries with internal diameter of 0.97 mm for sample handling as well as for rinsing solutions (they do not have to be in the scope of delivery of the instrument).

### Capillary connections

In order to achieve optimum analysis results, capillary connections in an IC system must be absolutely tight and free of dead volume. Dead volume occurs if two capillary ends connected to each other do not fit exactly, thus allowing liquid to escape. There are two possible reasons for this:

- The capillaries do not have exactly cut edges.
- The two capillary ends do not completely meet.

One prerequisite for dead volume free capillary connection is, that both capillary ends are cut exactly plane. Therefore we recommend only to cut PEEK capillaries with the capillary cutter (6.2621.080).

### Creating dead volume free capillary connections

To create dead volume free capillary connections, proceed as follows:

- 1** Slide the pressure screw over the capillary. Ensure that the capillary protrudes 1–2 mm from the tip of the pressure screw.
- 2** Plug the capillary all the way into the connection or coupling until the stop.
- 3** Only then start turning the pressure screw, while keeping the capillary pressed in space.



### Colored sleeves for PEEK capillaries

The enclosed set of varicolored sleeves for PEEK capillaries (6.2251.000) serves to easily differentiate the various flows of liquid in the system through color coding. Each capillary leading a given liquid (e. g. eluent) can be highlighted with sleeves of the same color.

To highlight a capillary, proceed as follows:

- 1 Slide a sleeve of a selected color over a capillary and move it to an easily visible position.

If the capillary heats up, the sleeve shrinks and adapts to the form of the capillary.

## 3.6 Installations on the rear of the instrument

### 3.6.1 Transport locking screws

To avoid damage to the high pressure pump drive during transport, the pump is secured with transport locking screws .

Remove these transport locking screws before the initial start-up.

#### Removing transport locking screws

- 1 Remove all of the transport locking screws with the 6.2621.030 4 mm hexagon key and keep them in a safe place.



#### Warning

In order to avoid damage to the pump, the transport locking screws must be remounted each time the instrument undergoes major transport.

### 3.6.2 Leak sensor

The leak sensor detects escaping liquid which collects in the base tray of the instrument.

For the leak sensor to function correctly, the following preconditions must be met:

- The leak sensor connector plug (5-2) is plugged into the **Leak Sensor** socket.
- The instrument is switched on.
- In the software, the leak sensor is set to **active**.

### Connecting the leak sensor

Connect the leak sensor as follows:

- 1** Pull out the leak sensor connection cable (5-3) from the base tray.
- 2** Plug the leak sensor connector plug (5-2) into the leak sensor connection socket (5-1) on the rear of the instrument.

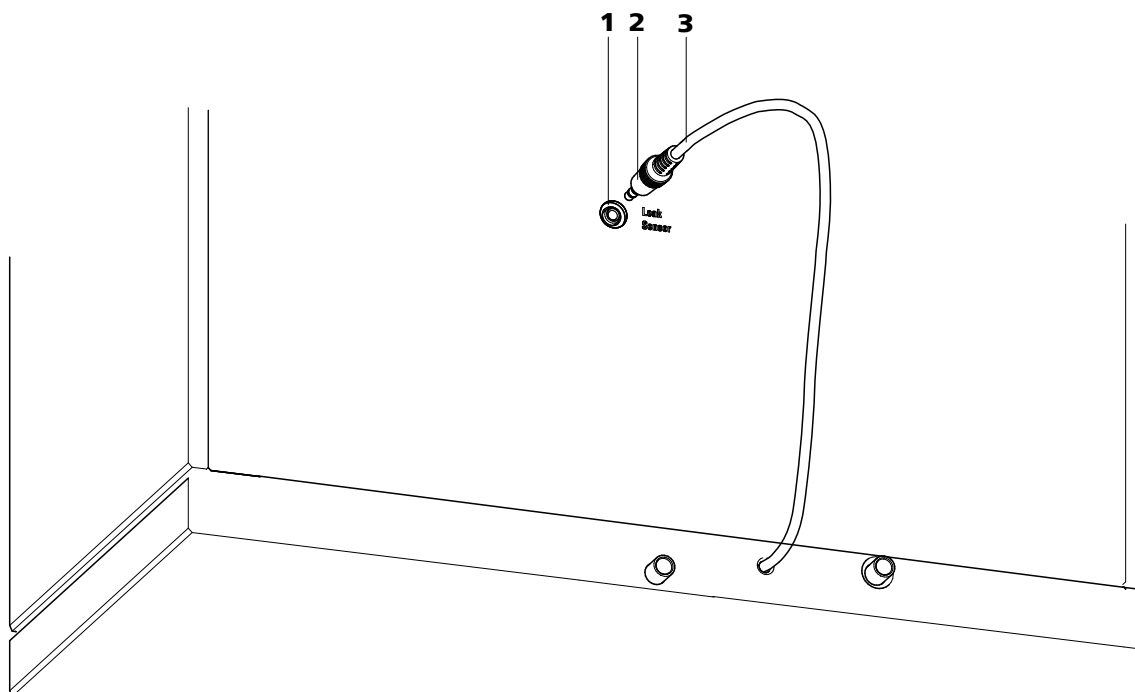

Figure 5 leak sensor – plugging in

**1 Leak sensor connection socket**

Is labeled with **Leak Sensor**.

**2 Leak sensor connector plug**

**3 Leak sensor connection cable**

Extractable. Coiled up in the base tray.

### 3.6.3 Drainage tubings

Fluid that escapes in the covering plate or in the detector chamber flows through the drainage tubings into the base tray and past the leak sensor into the waste container. This ensures that any leaks in the system will be detected by the leak sensor.

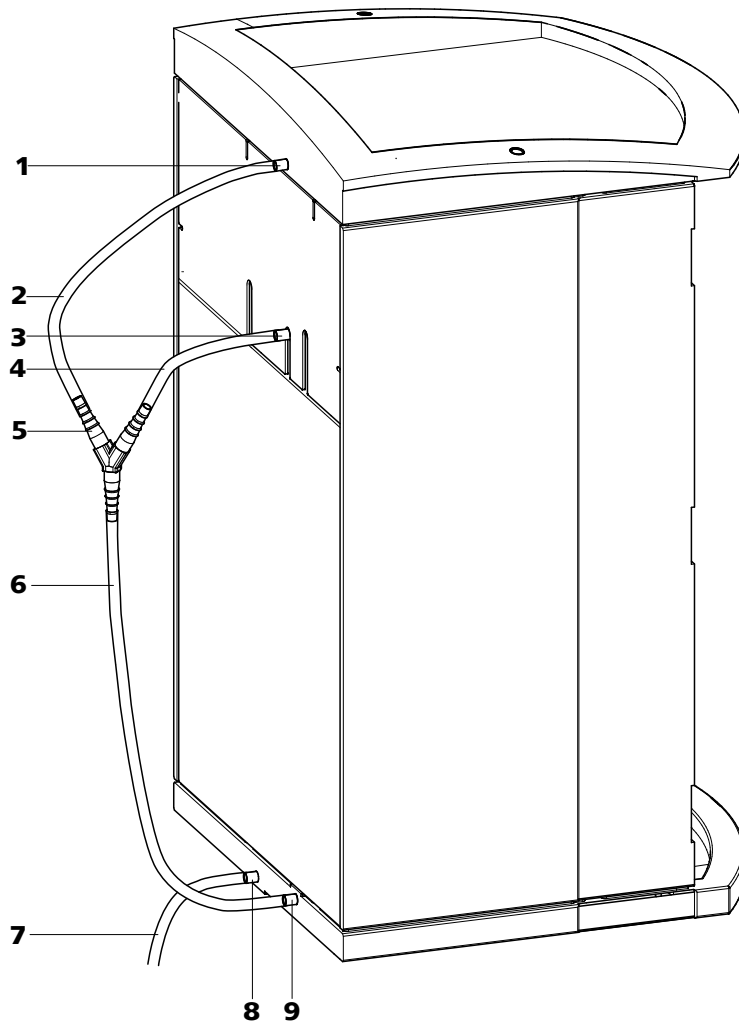

Figure 6 Drainage tubings

<p><b>1 Drainage tubing connection</b> For draining escaped liquid from the cover.</p>	<p><b>2 Drainage tubing</b> Section of the 6.1816.020 silicon tubing. For draining escaped liquid from the cover.</p>
<p><b>3 Drainage tubing connection</b> For draining escaped fluid from the detector chamber.</p>	<p><b>4 Drainage tubing</b> Section of the 6.1816.020 silicon tubing. For draining escaped fluid from the detector chamber.</p>
<p><b>5 Y connector (6.1807.010)</b> For connecting the two drainage tubings (6-2) and (6-4).</p>	<p><b>6 Drainage tubing</b> Section of the 6.1816.020 silicon tubing. Guides escaped fluid to the leak sensor.</p>
<p><b>7 Drainage tubing</b> Section of the 6.1816.020 silicon tubing. Guides escaped fluid into a waste container.</p>	<p><b>8 Drainage tubing connection</b> For draining escaped fluid.</p>
<p><b>9 Drainage tubing connection</b> Leads to the leak sensor.</p>	

### Installing drainage tubings

Proceed as follows to install the drainage tubings:

- 1** Connect drainage tubing (6-2) to the drainage tubing connection (6-1) and shorten to the required length.
- 2** Connect drainage tubing (6-4) to the drainage tubing connection (6-3) and shorten to the required length.
- 3** Connect drainage tubing (6-2) and drainage tubing (6-4) to the Y connector (6-5).
- 4** Connect drainage tubing (6-6) to the Y connector (6-5), shorten to the required length and connect the other end of the drainage tubing to the drainage tubing connection (6-9).
- 5** Connect drainage tubing (6-7) to the drainage tubing connection (6-8) and guide the other end into a waste container.

## 3.7 Capillary and cable feed-throughs

Several openings have been integrated for feeding through capillaries and cables. These can be found at the door, at the rear panel, and below the bottle holder and above the base tray (see Figure 7, page 24).

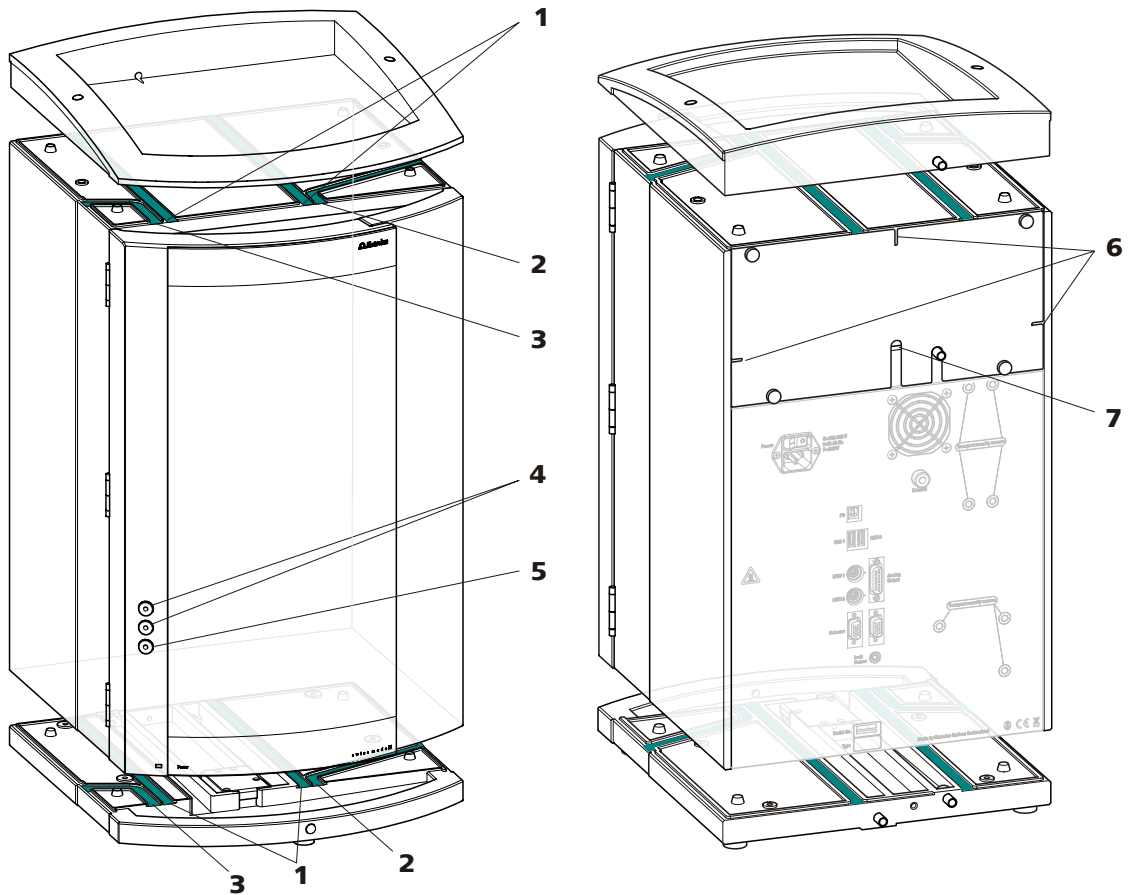

Figure 7 Capillary and cable feed-throughs

**1 Capillary feed-through**

For feeding capillaries from the front to the rear of the instrument.

**3 Capillary feed-through**

For feeding capillaries from the front to the left side of the instrument.

**5 Capillary feed-through**

At the door of the instrument. For feeding capillaries out of the instrument.

**7 Cable feed-through**

At the rear of the instrument. For feeding the detector cable out of the detector chamber.

**2 Capillary feed-through**

For feeding capillaries from the front to the right side of the instrument.

**4 Luer connector**

For connecting a (6.2816.020) syringe. For manual sample feeding.

**6 Capillary feed-through**

At the rear of the instrument. For feeding capillaries out of the detector chamber.

Do not feed capillaries through the Luer connectors (7-4). The capillaries are fastened with PEEK pressure screws (6.2744.070) from inside to the Luer connector. From outside, liquid can be aspirated or injected with a syringe.

## 3.8 Eluent

### 3.8.1 Connecting eluent bottle

The eluent is aspirated out of the eluent bottle via the eluent aspiration tubing (8-1).

The eluent aspiration tubing is connected to the high pressure pump (see Chapter 3.9, page 29) (see Chapter , page ). The tubing must be threaded through a suitable capillary feed-through (see Chapter 3.7, page 23) of the instrument before the other end can be equipped.

You will require the parts from the following accessories for equipping the eluent aspiration tubing:

- 6.1602.160 Eluent bottle attachment GL 45
- 6.2744.210 tubing adapter for aspiration filter
- 6.2821.090 aspiration filter

To equip the eluent aspiration tubing proceed as follows:

#### Assembling eluent aspiration tubing

- 1 Guide the free end of the eluent aspiration tubing (8-1) out of the instrument through a suitable capillary feed-through.
- 2 **Installing eluent bottle attachment (6.1602.160)**
  - Slide tubing nipple (8-2) and O-ring (8-3) onto the eluent aspiration tubing (8-1).
  - Push eluent aspiration tubing (8-1) through the bottle attachment (8-4) and screw tight.

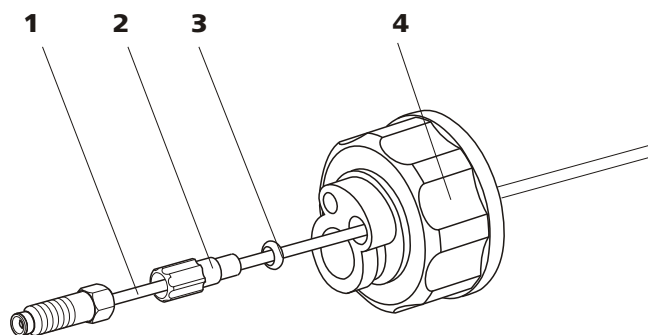

Figure 8 Installing eluent bottle attachment

**1 Eluent aspiration tubing (6.1834.080)**

**2 Tubing nipple**

From accessories set (6.1602.160).

**3 O-ring**

From accessories set (6.1602.160).

**4 Bottle attachment**

From accessories set (6.1602.160).

### 3 Mounting aspiration filter

- Insert filter holder (9-1) into the aspiration filter (9-2) and screw tight.

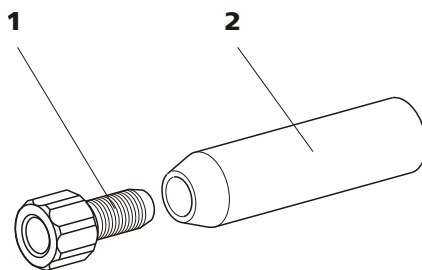

Figure 9 Mounting aspiration filter

**1 Filter holder**

From accessories set (6.2744.210).

**2 Aspiration filter (6.2821.090)**

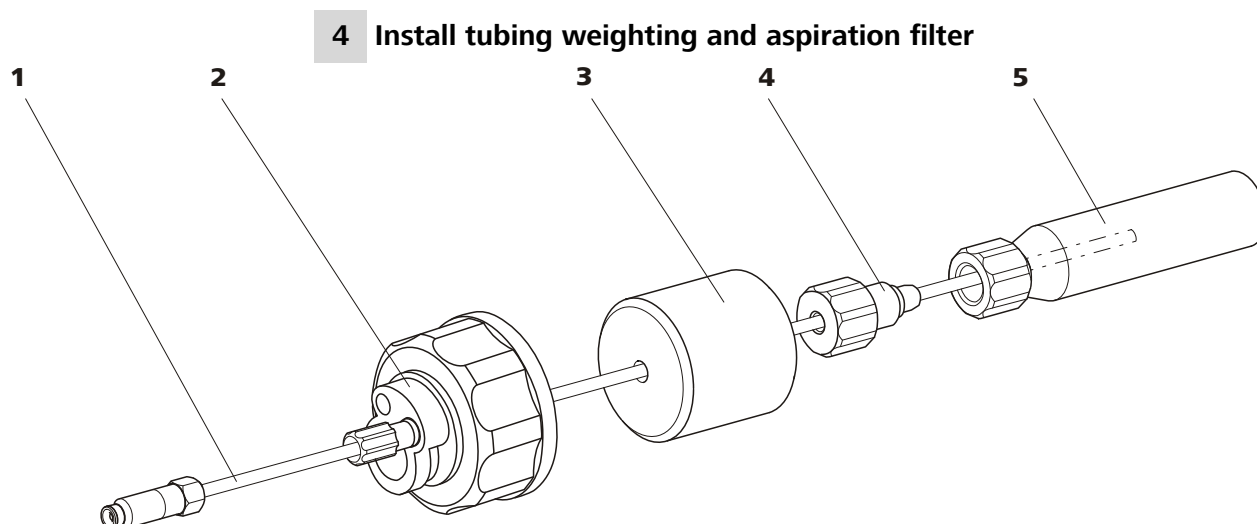

Figure 10 Install tubing weighting and aspiration filter

**1 Eluent aspiration tubing (6.1834.080)**

**2 Eluent bottle attachment (6.1602.160)**

**3 Tubing weighting**  
From accessories set (6.2744.210).

**4 Clamping screw**  
From accessories set (6.2744.210).

**5 Aspiration filter (6.2821.090)**  
With filter holder from accessories set  
(6.2744.210).

- Slide the tubing weighting (10-3) onto the eluent aspiration tubing (10-1).
- Slide the clamping screw (10-4) onto the eluent aspiration tubing (10-1).
- Insert eluent aspiration tubing (10-1) into the aspiration filter (10-5). The end of the tubing should approximately reach to the center of the aspiration filter.
- Screw together clamping screw (10-4) and filter holder (9-1).

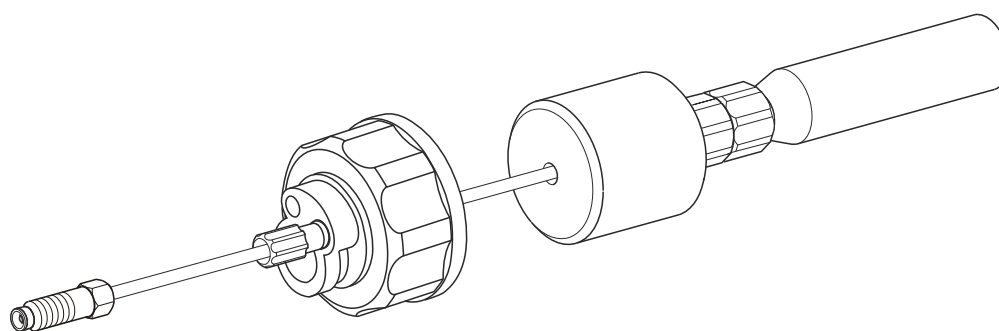

Figure 11 Eluent aspiration tubing fully equipped.

#### 5 Mounting eluent aspiration tubing to the eluent bottle

- Insert the eluent aspiration tubing into the eluent bottle (12-10).



- Fasten the completely equipped bottle attachment (10-2) on the eluent bottle (12-10). The aspiration filter (12-6) must rest on the base of the eluent bottle.
- Close the remaining small opening on the bottle attachment with a threaded stopper (12-14) from the accessories set.

## 6 Mounting the adsorber tube



### Note

If alkaline eluents and eluents with lower buffer capacity are used, the eluent bottle must be equipped with an adsorber tube filled with CO<sub>2</sub> adsorber (12-4).

- First, place a piece of cotton (12-3), then the CO<sub>2</sub> adsorber (12-4) in the large opening of the adsorber tube (12-2) and close with the plastic cover.
- Fasten the adsorber tube (12-2) onto the bottle attachment (12-11) using the SGJ clip (12-12).

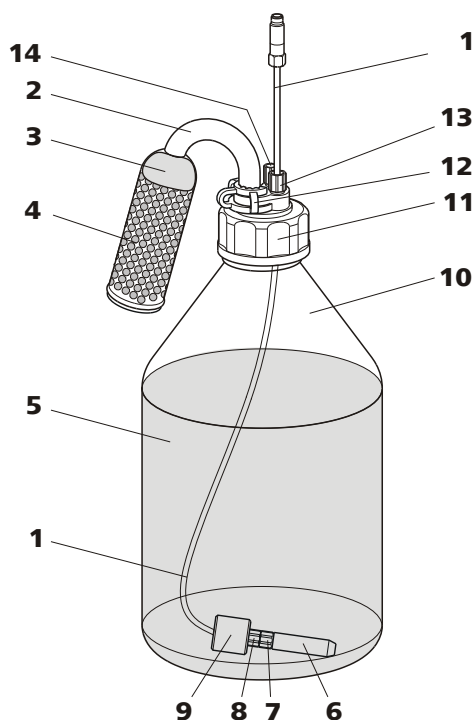

Figure 12 Eluent bottle – connected

**2 Eluent aspiration tubing (6.1834.080)**  
For aspirating the eluent. Pre-installed.

**2 Adsorber tube (6.1609.000)**

<b>3 Cotton</b>	<b>4 CO<sub>2</sub> adsorber</b> Adsorbs CO <sub>2</sub> from the air (e.g. Merck soda lime with indicator, no. 6839.10).
<b>5 Eluent</b>	<b>6 Aspiration filter (6.2821.090)</b>
<b>7 Filter holder</b> From accessories set (6.2744.210).	<b>8 Clamping screw</b> From accessories set (6.2744.210).
<b>9 Tubing weighting</b> From accessories set (6.2744.210).	<b>10 Eluent bottle (6.1608.070)</b>
<b>11 Bottle attachment (6.1602.160)</b>	<b>12 SGJ clip (6.2023.020)</b>
<b>13 Tubing nipple</b>	<b>14 Threaded stopper</b>

## 3.9 High pressure pump

The intelligent and low pulsation high pressure pump pumps the eluent through the system. It is equipped with a chip on which its technical specifications and "life history" (operating hours, service data, ...) are saved.

The purge valve is used for deaerating (*see Chapter 3.9.2, page 32*) the high pressure pump.

### 3.9.1 Capillary connections high pressure pump/purge valve



#### Note

All of the capillary connections of the high pressure pump and the purge valve are already installed in the newly delivered instrument.

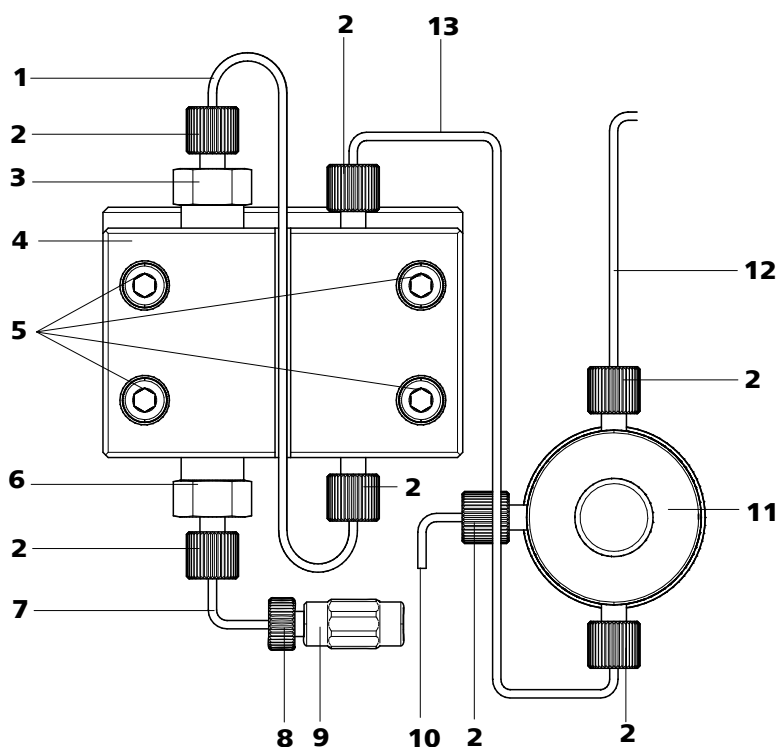

Figure 13 Capillary connections high pressure pump/purge valve

<p><b>1 Connection capillary</b> PEEK capillary, connects main piston and auxiliary piston.</p>	<p><b>2 PEEK pressure screw, short (6.2744.070)</b></p>
<p><b>3 Outlet valve holder</b></p>	<p><b>4 Pump head (6.2824.110)</b></p>
<p><b>5 Fastening screws</b> For fastening the pump head.</p>	<p><b>6 Inlet valve holder</b></p>
<p><b>7 Pump head inlet capillary</b> PEEK capillary at the input of the pump head.</p>	<p><b>8 Pressure screw</b> For connecting a PEEK capillary to the coupling (13-9).</p>
<p><b>9 Coupling</b> For the connection of the eluent path at the input of the high pressure pump. Can be ordered together with the pressure screw (13-8) under the number (6.2744.230).</p>	<p><b>10 Deaerating capillary</b> For aspirating the eluent when deaerating the high pressure pump (see Chapter 3.9.2, page 32).</p>
<p><b>11 Purge valve</b> For deaerating the high pressure pump. With rotary knob in the center and pressure sensor.</p>	<p><b>12 Connection capillary</b> For connecting the inline filter (see Chapter 3.10, page 34).</p>
<p><b>13 Connection capillary</b> Connects the output of the pump head with the purge valve.</p>	



### Note

The eluent aspiration capillary is already installed in the newly delivered instrument. The following installation instructions need **not** be carried out at the time of initial installation.

### Connecting inlet to the high pressure pump

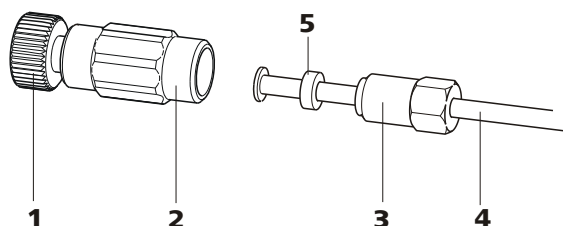

Figure 14 High pressure pump – Connect inlet

#### 1 Pressure screw

For connecting the coupling (14-2) to the pump head inlet capillary (13-7).  
Can be ordered together with the coupling under the number (6.2744.230).

#### 2 Coupling (6.2744.230)

For connecting the eluent connection capillary (14-4) to the input of the high pressure pump.

#### 3 Clamping screw

#### 4 Eluent aspiration tubing

Eluent aspiration tubing (6.1834.080) or (6.1834.090).

#### 5 Backup ring

### 1 Connecting coupling

Fasten the coupling (14-2) with a pressure screw (14-1) on the pump head inlet capillary (13-7).

### 2 Connecting eluent aspiration tubing



#### Caution

The clamping screws must be tightened carefully. To tighten, grip the coupling (14-2) with the key (6.2739.000) and grip the clamping screw (14-3) with the wrench (6.2621.050).

- Plug the eluent aspiration tubing (14-4) into the coupling (14-2).
- Tighten the clamping screw (14-3).



### 3.9.2 Deaerating the high pressure pump

The high pressure pump will only operate perfectly if the pump head contains no more air bubbles. Therefore it must be deaerated during initial start-up and after every change of eluent.



#### Caution

---

The high pressure pump must **not** be deaerated before the initial start-up (see Chapter 4.1, page 57).

Deaerate the high pressure pump as follows (see Figure 15, page 33):

### Deaerate the high pressure pump

The instrument must be connected to the PC and switched on to deaerate the high pressure pump.

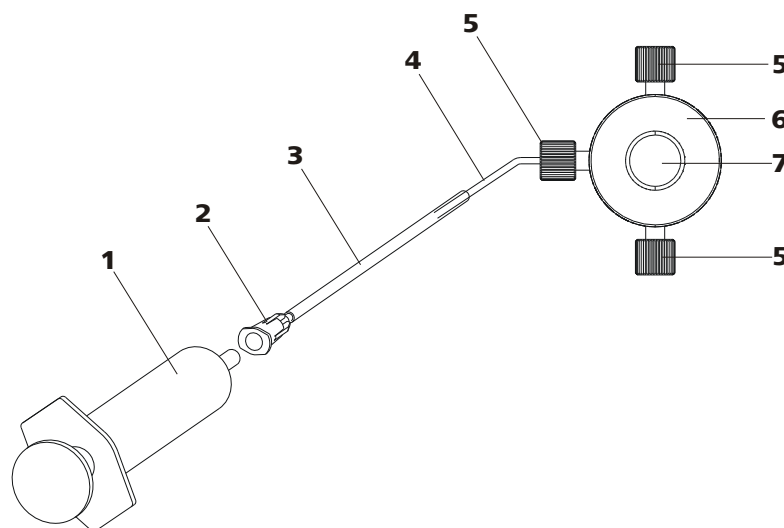

Figure 15 Deaerate the high pressure pump

<b>1 Syringe 10 mL (6.2816.020)</b> For aspirating the eluent.	<b>2 Luer connector</b> Part of the purging needle (6.2816.040)
<b>3 Purging needle (6.2816.040)</b>	<b>4 Deaerating capillary</b>
<b>5 PEEK pressure screws, short (6.2744.070)</b>	<b>6 Purge valve</b>
<b>7 Purge valve rotary knob</b>	

#### 1 Connecting the purging needle

- Push the end of the purging needle (15-3) over the end of the deaerating capillary (15-4) on the purge valve.

#### 2 Connecting the syringe

- Insert syringe (15-1) in the Luer connector (15-2) of the purging needle (see Figure 15, page 33).

#### 3 Opening purge valve

- Open the rotary knob (15-7) by approx. ½ rotation counterclockwise.



#### 4 Setting the flow rate

- Start MagIC Net™ (if not yet started).
- Ensure that the eluent aspiration tubing is immersed sufficiently in the eluent.
- Let the high pressure pump run.

#### 5 Aspirating eluent

- Aspirate with the syringe (15-1) until bubble-free eluent flows into the syringe.

#### 6 Completing deaerating

- Switch off high pressure pump.
- Close rotary knob (15-7).
- Remove syringe (15-1) from the Luer connector (15-2).
- Pull the purging needle (15-3) out of the deaerating capillary (15-4).

### 3.10 Inline filter

Between the purge valve and the pulsation absorber the inline filter (6.2821.120) is installed as protection against particles.

Inline filters protect the separation column securely against possible contamination from the eluent. Inline filters can however also just as well be used for the purpose of protecting the suppressor against contaminations in the regeneration or rinsing solutions. The filter platelets with a pore size of 2 µm can be replaced quickly and easily. They remove particles like e. g. bacteria and algae from the solutions.



#### Note

The inline filter is already installed in the newly delivered instrument. The following installation instructions need **not** be carried out at the time of initial installation.

### Installing the inline filter



#### Caution

Observe the flow direction marked on the filter housing for the connection of the inline filter.

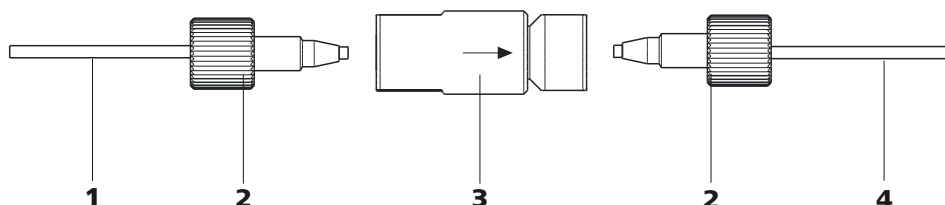

Figure 16 Connecting the inline filter

#### 1 Connection capillary

Connects the purge valve with the inline filter

#### 3 Inline filter (6.2821.120)

Protects against particles.

#### 2 PEEK pressure screws, short (6.2744.070)

#### 4 Connection capillary

Connects the inline filter with the pulsation absorber.

- 1 Screw on the connection capillary running from the purge valve to the input side of the inline filter using a pressure screw (6.2744.070).
- 2 Screw on the connection capillary running to the pulsation absorber to the output side of the inline filter using a pressure screw (6.2744.070).

## 3.11 Pulsation absorber



#### Note

The pulsation absorber is already installed in the newly delivered instrument.



#### Caution

The pulsation absorber is maintenance-free and may not be opened.



The pulsation absorber protects the separation column from damage caused by pressure fluctuations when switching the injection valve, and reduces interfering pulsations during highly sensitive measurements. In order to ensure these functionalities, it must be connected between the high pressure pump (see Chapter 3.9, page 29) and injection valve (see Chapter 3.12, page 36).

The pulsation absorber can be operated in both directions.

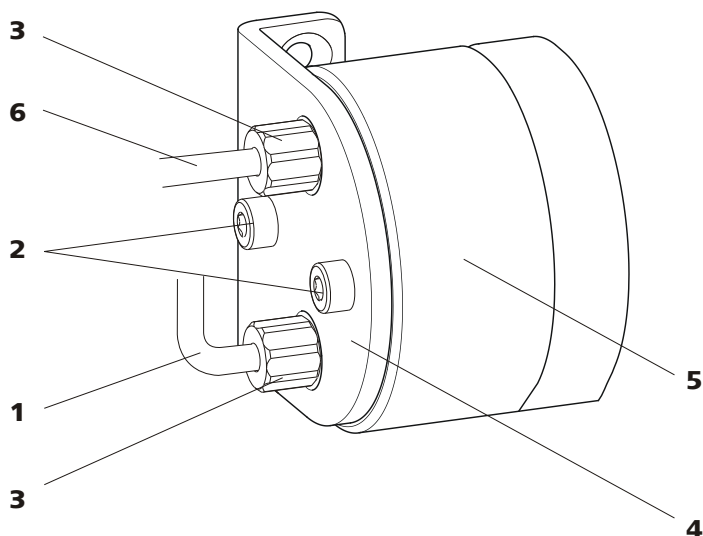

Figure 17 Pulsation absorber – Connection

<b>1</b>	<b>Connection capillary</b> Connection to the inline filter.	<b>2</b>	<b>Fastening screws</b>
<b>3</b>	<b>PEEK pressure screws, short</b> (6.2744.070)	<b>4</b>	<b>Holder for pulsation absorber</b>
<b>5</b>	<b>Pulsation absorber (6.2620.150)</b>	<b>6</b>	<b>Connection capillary</b> Connection to the injection valve.

## 3.12 Injection valve

The injection valve connects the eluent and sample path. Through rapid and precise valve switchover a precise amount of sample solution defined by the size of the sample loop is injected and rinsed with eluent onto the separation column.

### 3.12.1 Connecting the injection valve

The injection valve has six connectors: two for the sample path (connectors 1 and 2), two for the eluent path (connectors 4 and 5) and two for the sample loop (connectors 3 and 6).

**Note**

The capillaries of the eluent path and the sample path and the sample loop are already installed in the newly delivered instrument.

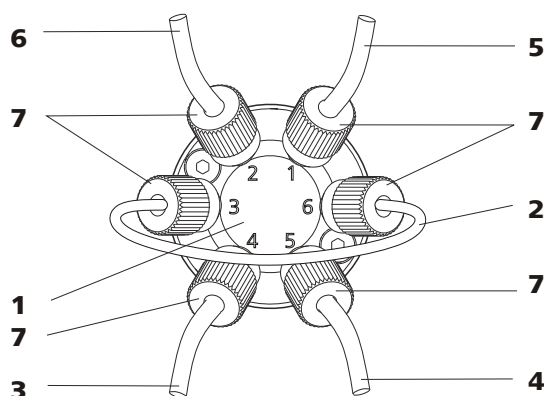

Figure 18 Injection valve – connected

**1 Injection valve****2 Sample loop**

Connected to connectors 3 and 6.

**3 Connection capillary**

Connected to connector 4. Carries eluent to the injection valve.

**4 Connection capillary (column inlet capillary)**

Connected to connector 5. Carries eluent to the separation column.

**5 Connection capillary**

Connected to connector 1. Carries sample to the injection valve.

**6 Connection capillary**

Connected to connector 2. Carries sample to the waste container.

**7 PEEK pressure screw 6.2744.010****Replacing the sample loop**

The sample loop can be replaced, depending on requirements. For additional information concerning selection of the appropriate sample loop, see *Chapter 3.12.3, page 39*.

**Note**

Use only 6.2744.010 PEEK pressure screws for connecting capillaries and sample loop to the injection valve.

**1 Removing existing sample loop**

- Loosen 6.2744.010 pressure screws at connector 3 and connector 6.
- Remove sample loop.



## 2 Mounting new sample loop

- Fasten one end of the sample loop (18-2) with a 6.2744.010 PEEK pressure screw (18-7) to connector 3.
- Fasten the other end of the sample loop (18-2) with a second 6.2744.010 PEEK pressure screw (18-7) to connector 6.

### 3.12.2 Mode of operation of the injection valve

The injection valve (see Figure 19, page 38) can adopt two valve positions - **FILL** and **INJECT**. Switching back and forth between the two valve positions determines whether the sample path or the eluent path is guided through the sample loop. The following figure provides a schematic display of the flow paths of the two valve positions.

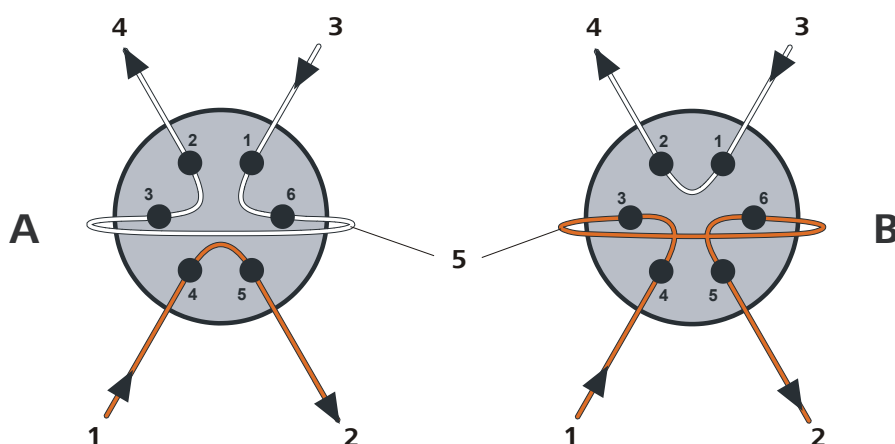

Figure 19 Injection valve – Positions

A	Position FILL	B	Position INJECT
1	<b>Eluent input</b> Capillary coming from the high pressure pump.	2	<b>Eluent output</b> Capillary to the column.
3	<b>Sample input</b> Sample aspirating capillary.	4	<b>Sample output</b> Capillary to waste container.
5	<b>Sample loop</b>		

#### Position A

In the position **FILL**, the sample solution flows through the sample loop to the waste container. The eluent flows directly to the separation column at the same time.

**Position B**

In the position **INJECT**, the eluent flows through the sample loop to the separation column. If sample solution is to be found in the sample loop at the time of the valve switchover, then this will be conveyed along with the eluent, thus making its way to the separation column. The flow in the sample path is either stopped or the sample flows directly to the waste container.

**3.12.3 Selecting the sample loop**

The amount of sample solution injected depends on the volume of the sample loop. The choice is made on the basis of the application. The following sample loops are normally used:

Cation determination	10 µL
Anion determination with suppression	20 µL
Anion determination without suppression	100 µL

**3.13 Peristaltic pump****3.13.1 Principle of the peristaltic pump**

The Peristaltic pump is used for pumping sample and auxiliary solutions. It can rotate in both directions.

The peristaltic pump pumps liquids according to the principle of displacement. The pump tubing is clamped between the rollers (20-3) and the tubing cartridge (20-5). During operation, the peristaltic pump drive rotates the roller hub (20-2), so that the rollers (20-3) push the liquid forward in the pump tubing.

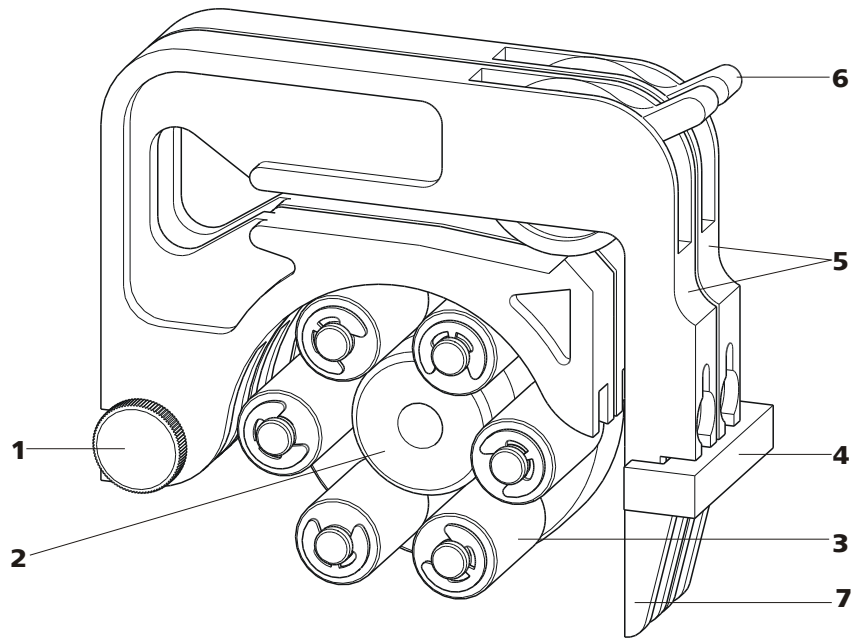

Figure 20 Peristaltic pump

<b>1</b>	<b>Knurled screw in the mounting pin</b>	<b>2</b>	<b>Roller hub</b>
<b>3</b>	<b>Rollers</b>	<b>4</b>	<b>Cartridge holder</b>
<b>5</b>	<b>Tubing cartridges 6.2755.000</b>	<b>6</b>	<b>Contact pressure lever</b>
<b>7</b>	<b>Snap-action lever</b>		

### 3.13.2 Installing the peristaltic pump

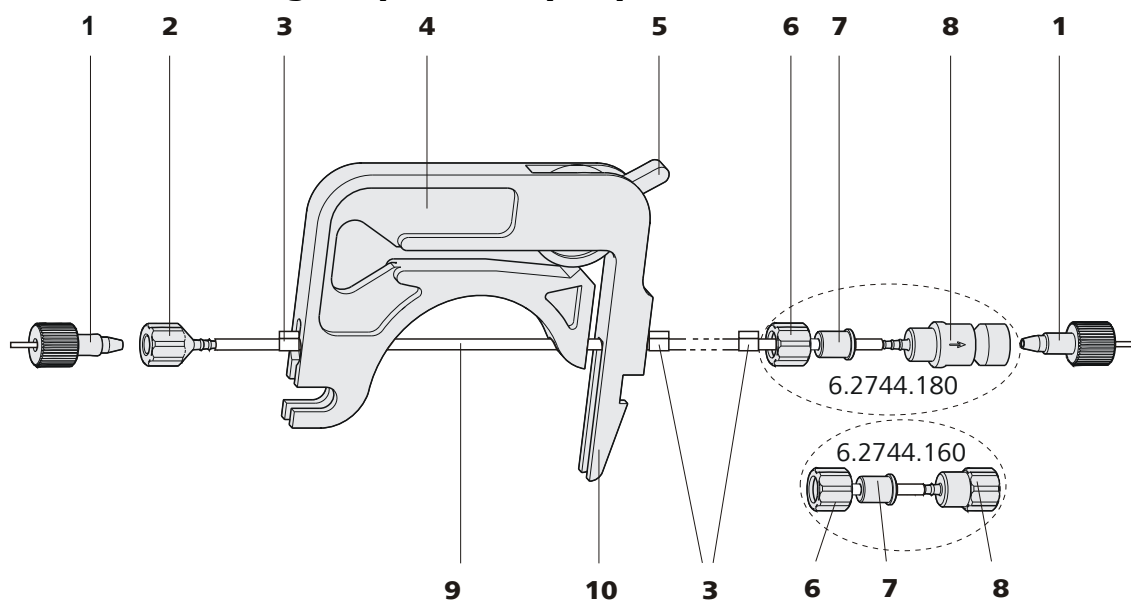

Figure 21 Installing the pump tubing

<b>1</b>	<b>PEEK pressure screws, short (6.2744.070)</b>	<b>2</b>	<b>Tubing olive (6.2744.034)</b>
<b>3</b>	<b>Stopper</b> The colors of the stopper indicate the inner diameter of the pump tubing.	<b>4</b>	<b>Tubing cartridge (6.2755.000)</b>
<b>5</b>	<b>Contact pressure lever</b>	<b>6</b>	<b>Union nut</b>
<b>7</b>	<b>Adapter</b>	<b>8</b>	<b>Tubing olive</b> Either with filter holder (6.2744.180) or without filter holder (6.2744.160).
<b>9</b>	<b>Pump tubing (6.1826.xx0)</b>	<b>10</b>	<b>Snap-action lever</b>

Mount the pump tubing as follows:

#### 1 Removing the tubing cartridge

Release the tubing cartridge from the cartridge holder by pressing the snap-action lever and unhooking from the mounting pins (20-1).

#### 2 Connecting the aspiration side

Place a 6.2744.034 tubing olive (21-2) on the aspiration side of the pump tubing.



### 3 Connecting the pressure side



#### Note

Depending on the use of the peristaltic pump, on the pressure side you can either connect:

- **Case A:** a 6.2744.180 pump tubing connection **with filter** (see Figure 22, page 42) or
- **Case B:** a 6.2744.160 pump tubing connection **without filter** (see Figure 23, page 43).

For pumping the auxiliary solutions to the MSM or to the SPM, a 6.2744.180 pump tubing connection **with filter must** be used.

**Case A:** 6.2744.180 pump tubing connection with filter:

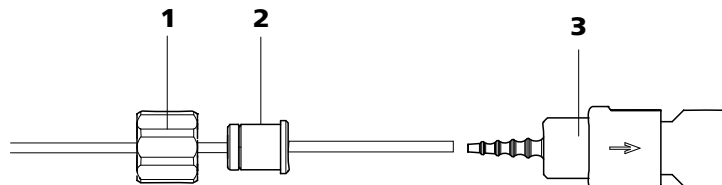

Figure 22 Install pump tubing connection with filter

**1 Union nut**

**2 Adapter**

**3 Tubing olive with filter holder**

- Slide union nut (22-**1**) onto the pump tubing.
- Select a suitable adapter (22-**2**) and slide it onto the pump tubing. The type of adapter depends on the pump tubing (see Table 1, page 43).
- Place the tubing olive with filter holder (22-**3**) onto the pump tubing.
- Screw the union nut (22-**1**) onto the tubing olive (22-**3**).

or

**Case B:** 6.2744.160 pump tubing connection without filter:

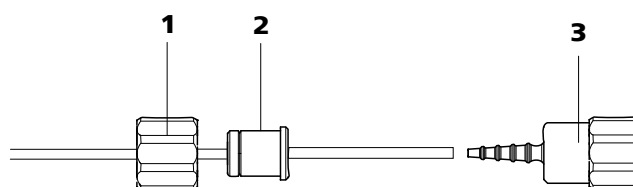

Figure 23 Install pump tubing connection without filter

**1 Union nut**

**2 Adapter**

**3 Tubing olive**

- Slide union nut (23-**1**) onto the pump tubing.
- Select a suitable adapter (23-**2**) and slide it onto the pump tubing. The type of adapter depends on the pump tubing (see Table 1, page 43).
- Place the tubing olive (23-**3**) onto the pump tubing.
- Screw the union nut (23-**1**) onto the tubing olive (23-**3**).

#### 4 Inserting the pump tubing

- Press the contact pressure lever all the way down.
- Place the pump tubing in the tubing cartridge. The stoppers (21-**3**) must snap into the corresponding holders of the tubing cartridge.





#### 5 Inserting the tubing cartridge

- Hang the tubing cartridge in the mounting pin and press in the cartridge holder until the snap-action lever snaps in.





#### 6 Connecting the capillaries

- Screw the respective capillaries tightly to the two tubing olives with PEEK pressure screws (21-**1**).

Table 1 Pump tubings and suitable adapters

Pump tubing	Adapter
6.1826.020 (blue/blue)	
6.1826.310 (orange/green)	
6.1826.320 (orange/yellow)	
6.1826.330 (orange/white)	



Pump tubing	Adapter
6.1826.340 (black/black)	
6.1826.360 (white/white)	
6.1826.380 (gray/gray)	
6.1826.390 (yellow/yellow)	

### Set flow rate

The contact pressure of the tubing cartridge must be adjusted in order to regulate the flow rate. Proceed as follows:

#### Set the contact pressure

- 1
  - Fully loosen the contact pressure lever (21-5), i.e. press it all the way down.
  - Switch on the peristaltic pump.
  - Raise the contact pressure lever one step at a time until liquid flows.
  - When liquid starts flowing, raise the contact pressure lever by an additional 2 ratchet increments.

The contact pressure is now set optimally.

The delivery rate depends not only on the correct contact pressure but also on the interior diameter of the pump tubing and the rotational speed of the drive.



#### Note

Pump tubings are consumable material. The service life of the pump tubings depends on the contact pressure amongst other factors.

## 3.14 Metrohm Suppressor Module (MSM)

The MSM is used for chemical suppression during anion analysis with conductivity detection or UV/VIS detection. It consists of 3 suppressor units in total, which are, in rotation, used for suppression – regenerated with 100 mmol/L sulfuric acid – rinsed with ultrapure water.

### Suppression reaction in the MSM

When using a carbonate eluent, the following reaction (amongst others) occurs in the MSM:

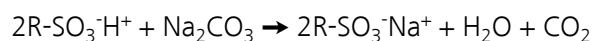

### 3.14.1 Connecting the suppressor

The three inputs and outputs of the suppressor units, numbered with 1, 2 and 3 on the connecting piece, each have 2 fixed mounted PTFE capillaries.

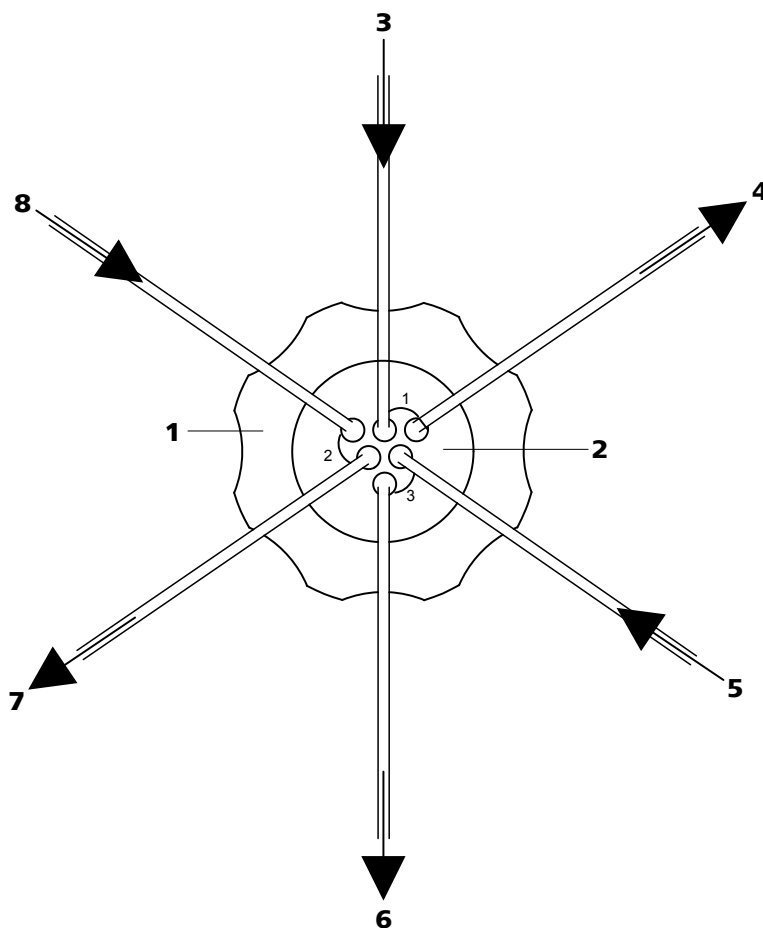

Figure 24 Suppressor – connection capillaries

<b>1</b> Union nut	<b>2</b> Connecting piece (6.2832.010)
<b>3</b> Eluent inlet capillary Labeled with <b>in</b> .	<b>4</b> Eluent outlet capillary Labeled with <b>out</b> .
<b>5</b> Rinsing solution inlet capillary Labeled with <b>rinsing solution</b> .	<b>6</b> Rinsing solution outlet capillary Labeled with <b>waste rins..</b>
<b>7</b> Regeneration solution outlet capillary Labeled with <b>waste reg..</b>	<b>8</b> Regeneration solution inlet capillary Labeled with <b>regenerant</b> .

The rinsing solution and regeneration solution are pumped with a peristaltic pump (see Chapter 3.13, page 39).



**Caution**

To protect the suppressor against foreign particles or bacterial growth, a pump tubing connection with filter (6.2744.180) (22-**3**) must be mounted between the peristaltic pump and the inlet capillaries of the suppressor.

Connect the PTFE capillaries firmly mounted on the connecting piece to the other components of the IC system as follows:

### Connecting the capillaries of the suppressor

In order to protect the Suppressor from foreign particles or bacterial growth, the following precondition must be fulfilled:

- Pump tubing connections with filter (6.2744.180) are installed at the pump tubing outlets of the peristaltic pump.



#### Caution

As the PTFE capillaries are very soft, the pressure screws should not be overtightened.

Squeezed capillary ends can be shortened with the capillary cutter (6.2621.080).

### 1 Connecting the eluent inlet capillary

- Fasten the end of the inlet capillary labeled with **in** to the output of the column with a short PEEK pressure screw (6.2744.070).

### 2 Connecting the eluent outlet capillary



#### Note

Depending on the instrument type, the suppressor is either connected directly with the detector or, if available and used, with the MCS.

- Connect the output capillary labeled with **out** either with the **detector** (*see manual of the detector*).

or

- Connect the output capillary labeled with **out** with the input **in** of the **MCS**, using a long PEEK pressure screw (6.2744.090).

### 3 Connecting the rinsing solution inlet capillary

- With a short PEEK pressure screw (6.2744.070), fasten the end of the inlet capillary labeled with **rinsing solution** to the pump tubing connection of the pump tubing which carries the rinsing solution.

**4 Connecting the rinsing the solution outlet capillary**

- Guide the other end of the outlet capillary labeled with **waste rins.** into a sufficiently large waste container and fasten it there.

**5 Connecting the regeneration solution inlet capillary**

- With a short PEEK pressure screw (6.2744.070), fasten the end of the inlet capillary labeled with **regenerant** to the pump tubing connection of the pump tubing which carries the regeneration solution.

**6 Connecting the regeneration solution outlet capillary**

- Guide the other end of the outlet capillary labeled with **waste reg.** into a sufficiently large waste container and fasten it there.

## 3.15 Metrohm CO<sub>2</sub> Suppressor (MCS)

### 3.15.1 General information on the MCS

The Metrohm CO<sub>2</sub> Suppressor (MCS) removes the CO<sub>2</sub> from the eluent flow. This reduces the background conductivity, improves the detection sensitivity and minimizes the injection and carbonate peaks.

CO<sub>2</sub> can reach the eluent flow through the sample itself or arise through the suppression reaction in the MSM/. The CO<sub>2</sub> peak is effectively minimized through connection of the MCS between the MSM and detector.

The principle of the MCS is based on the gas permeability of the fluoropolymer membrane inside the degassing cell of the MCS. The eluent is guided through a capillary with a fluoropolymer membrane inside the degassing cell. A vacuum is generated in the degassing cell by the pump, at the same time, the pump sucks CO<sub>2</sub>-free air – ambient air is aspirated through a CO<sub>2</sub> adsorption cartridge (26-4), which removes the CO<sub>2</sub>. The pressure and concentration difference in the degassing cell in comparison to the inside of the capillary now causes the CO<sub>2</sub> to diffuse out of the eluent flow.

### 3.15.2 Connecting MCS

The MCS is connected between the MSM and detector.

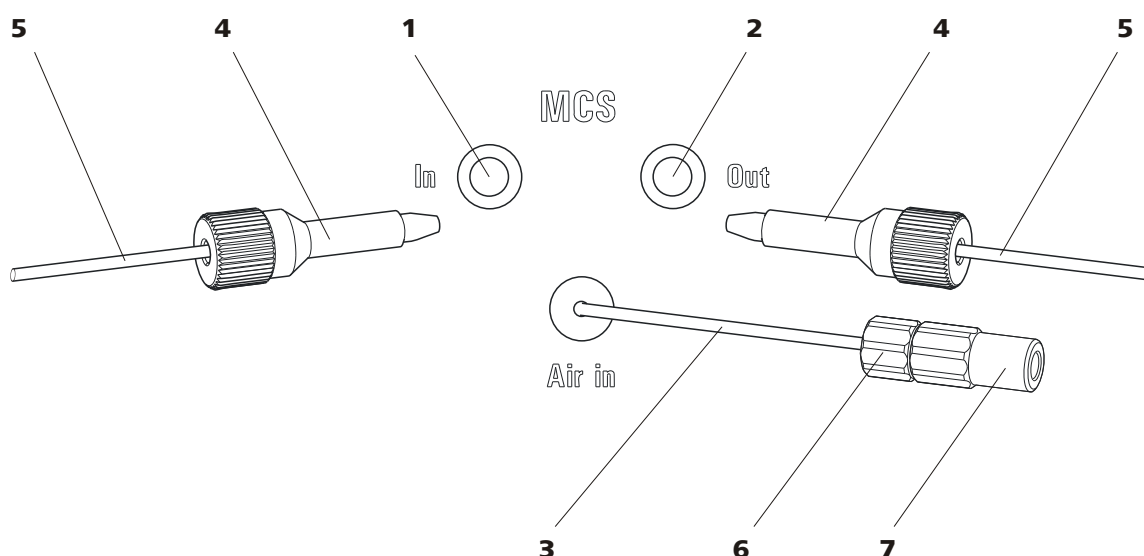

Figure 25 MCS – connection

<p><b>1 MCS input</b> Connection to the MSM.</p>	<p><b>2 MCS output</b> Connection to the detector.</p>
<p><b>3 Aspirating capillary</b> For aspirating air low in CO<sub>2</sub> (as a result of CO<sub>2</sub> adsorption cartridge (26-4)).</p>	<p><b>4 PEEK pressure screw, long (6.2744.090)</b></p>
<p><b>5 Capillary connection</b></p>	<p><b>6 Pressure screw, short (6.2744.070)</b> Mounted on the air aspirating capillary.</p>
<p><b>7 Luer coupling (6.2744.120)</b> Mounted on the air aspirating capillary with pressure screw 6.2744.070.</p>	

### Connecting the MCS

#### 1 Connecting the MSM

Connect the eluent outlet capillary (labeled with *out*) to the MCS inlet (25-1) using a long PEEK pressure screw (6.2744.090) (25-4).

#### 2 Connection to the detector

Connect the detector inlet capillary to the MCS output (25-2) using a long PEEK pressure screw (6.2744.090) (25-4).



#### Caution

If the MCS is not used, the input and output must be sealed with 6.2744.220 stoppers.



### 3.15.3 Installing the adsorption cartridges

For effective CO<sub>2</sub> removal, the air sucked through the degassing cell should be as low in CO<sub>2</sub> as possible. To achieve this, the air is aspirated through a CO<sub>2</sub> adsorption cartridge (6.2837.000) (26-4)..

Moisture can block the CO<sub>2</sub> adsorption cartridge. In order to prevent this, a H<sub>2</sub>O adsorption cartridge (6.2837.010) (26-7) is connected upstream.

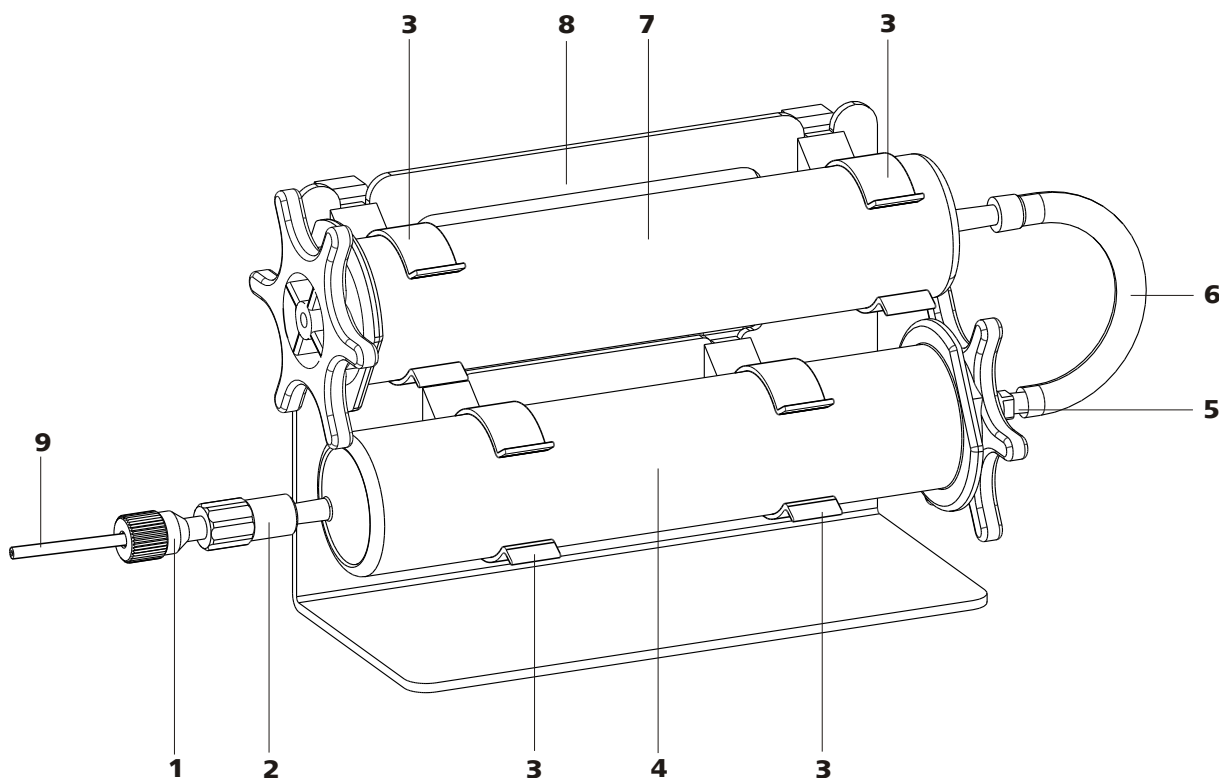

Figure 26 Adsorption cartridge holder

**1 PEEK pressure screw, short**  
(6.2744.070)

**3 Clips**  
For fastening the adsorption cartridges.

**5 Adapter (6.1808.190)**  
For connecting the H<sub>2</sub>O adsorption cartridge and CO<sub>2</sub> adsorption cartridge.

**2 Luer coupling (6.2744.120)**

**4 CO<sub>2</sub> adsorption cartridge (6.2837.000)**  
For removing the CO<sub>2</sub> from the aspirated air.  
3-layer filled, blue-brown-gray.

**6 PVC tubing**  
For connecting the H<sub>2</sub>O adsorption cartridge and CO<sub>2</sub> adsorption cartridge.

**7 H<sub>2</sub>O adsorption cartridge (6.2837.010)**  
For removing the H<sub>2</sub>O from the aspirated air.  
Filled with bead desiccant.

**8 Adsorption cartridge holder (6.2057.080)**

**9 MCS aspirating capillary**  
Connection to the MCS. Corresponds to (25-3).

### Installing the adsorption cartridges

#### 1 Preparing the adsorption cartridge holder

Push the 4 clips (26-3) into the slot of the adsorption cartridge holder (26-8).

#### 2 Removing the caps

- Remove the two sealing caps at the tip of the two cartridges.
- In the case of the H<sub>2</sub>O adsorption cartridge, replace the round sealing cap on the larger end with the star-shaped sealing cap.

#### 3 Connecting the CO<sub>2</sub> adsorption cartridge

- Insert the CO<sub>2</sub> adsorption cartridge into the coupling (26-2) on the end of the MCS aspirating capillary (3-15).
- Click the CO<sub>2</sub> adsorption cartridge into the two lower clips (26-3) of the adsorption cartridge holder (26-8).

#### 4 Connecting the PVC tubing

- Insert the adapter (26-5) into the CO<sub>2</sub> adsorption cartridge.
- Fasten the PVC tubing (26-6) on the adapter (26-5).

#### 5 Connecting the H<sub>2</sub>O adsorption cartridge

- Place the H<sub>2</sub>O adsorption cartridge into the PVC tubing (26-6).
- Click the H<sub>2</sub>O adsorption cartridge into the two upper clips (26-3) of the adsorption cartridge holder (26-8).

#### 6 Placing the adsorption cartridge holder in the instrument

- Place the adsorption cartridge holder with cartridges into the detector chamber of the instrument



## 3.16 Connecting the instrument

### 3.16.1 Connecting the instrument to the PC



#### Note

The instrument must be switched off when connecting the PC.

#### 1 Connecting the USB cable

Connect the PC connection socket of the instrument to a USB connector of the computer via the (6.2151.020) USB cable.

### 3.16.2 Connecting the instrument to mains supply



#### Warning

The power supply unit must not get wet. Protect it against the direct effect of liquids.

#### Mains cable

Which mains cable is supplied depends on the location:

- 6.2122.020 with plug SEV 12 (Switzerland, ...)
- 6.2122.040 with plug CEE(7), VII (Germany, ...)
- 6.2122.070 with plug NEMA 5-15 (USA, ...)

The mains cable is three-core and provided with a plug with grounding. If another plug has to be mounted, the yellow/green conductor (IEC standard) must be connected to the protective ground (protection class I).

#### 1 Connecting the mains cable

- Plug the mains cable into the mains connection socket .
- Connect the mains cable to the mains supply.

#### 2 Switching on the instrument

Switch on the instrument using the mains switch .

After switching on, the LED on the front of the instrument flashes while a system test is carried out and the connection to the software is established. Once the system test is complete and the connection to the software has been established, the LED lights up continuously.

## 3.17 Guard column

The use of guard columns serves for protecting the separation columns and increasing their service life considerably. The guard columns available from Metrohm represent either actual guard columns or are so-called guard column cartridges which are used together with a cartridge holder. The installation of a guard column cartridge in the associated holder is described in the leaflet of the guard columns.



### Note

Information regarding which guard column is suitable for your separation column can be found in the **Metrohm IC Column Program** (which is available from your Metrohm agent), the leaflet provided along with your separation column, the product information on the separation column at <http://www.metrohm.com> (product area Ion Chromatography), or obtained directly from your agent.



### Caution

New guard columns are filled with solution and are sealed on both sides with stoppers or caps, respectively. Before using the guard column, you need to ensure that this solution is miscible with the eluents used (observe manufacturer's data).



### Note

The guard column may only be installed after the **initial start-up** (see *Chapter 4.1, page 57*) of the instrument. Until then, use the coupling (6.2744.040) instead of the guard and separation column.



### Note

Metrohm recommends, always to work with guard columns. These protect the separation column and can be exchanged regularly.



## Connecting and rinsing the guard column

### 1 Connecting the guard column



#### Caution

When inserting the guard column, always ensure that it is inserted correctly corresponding to the flow direction (if indicated).

- Remove sealing caps and/or stoppers from the guard column.
- Fasten the input of the guard column to the column inlet capillary using a short PEEK pressure screw (6.2744.070).
- In case the guard column is mounted on the separation column with a connecting capillary, connect the included connection capillary, which is included with the guard column, to the output of the guard column using the PEEK pressure screw, which is also included.

### 2 Rinsing the guard column

- Place beaker under the outlet capillary of the guard column.
- Set the flow rate of the high pressure pump according to the data given in the leaflet of the separation column.
- Start the high pressure pump and rinse the guard column approx. 5 minutes with eluent.
- Switch off the high pressure pump again.

## 3.18 Separation column

The intelligent separation column (iColumn) is the heart of the ion chromatographic analysis. It separates the different components corresponding to their interactions with the column. Metrohm separation columns are equipped with a chip on which their technical specifications and their history (first use / setting up, operating hours, injections, ...) are saved.



#### Note

Information regarding which separation column is suitable for your application can be found in the **Metrohm IC Column Program**, the product information for your separation column at <http://www.metrohm.com> in the product area ion chromatography, or obtained directly from your agent.



### Caution

New separation columns are filled with solution and are sealed on both sides with stoppers. Before using the column, you need to ensure that this solution is miscible with the eluents used (observe manufacturer's data).

You can find the separation columns and guard columns currently available from Metrohm in the Metrohm IC Column Program, or in the Internet at <http://www.metrohm.com> in the product area Ion Chromatography. A test chromatogram and an leaflet are provided along with each column. You can request detailed information on special IC applications in the corresponding "**Application Bulletins**" or "**Application Notes**", available in the Internet at <http://www.metrohm.com> in the Applications area or via the Metrohm agent responsible free of charge.



### Note

The separation column may only be installed after the **initial start-up** (see Chapter 4.1, page 57) of the instrument. Until then, use the coupling (6.2744.040) instead of the guard and separation column.

## Connecting and rinsing the separation column

### 1 Connect the separation column



### Caution

When inserting the columns, always ensure that these are correctly inserted corresponding to the flow direction indicated.

- Remove stoppers from the separation column.
- Attach the guard column to the input of the separation column.  
OR  
Connect the input of the separation column to the outlet capillary of the guard column, using the PEEK pressure screw (6.2744.070) included.  
OR  
If no guard column is used (not recommended), connect the column input capillary to the input of the separation column, using a PEEK pressure screw (6.2744.070).



## 2 Rinsing the separation column

- Place beaker under the outlet end of the separation column.
- Set the flow rate of the high pressure pump according to the data given in the leaflet of the separation column.
- Start the high pressure pump and rinse the separation column approx. 10 minutes with eluent.
- Switch off the high pressure pump again.

## 3 Mounting the separation column

- Fasten the column output capillary to the output of the separation column using a PEEK pressure screw (6.2744.070).
- Hang separation column with chip into the column holder.



### Note

---

The iColumns are equipped with a chip on which their operating data is saved. The chip has to be hooked into the chip holder provided for this so that the column recognition can function.

## 4 Start-up

The chapter *Start-up* is divided into 2 sections:

<b>Initial start-up</b>	The <b>initial start-up</b> is carried out during the <b>initial installation</b> .
<b>Conditioning</b>	Conditioning is carried out as a final installation step and each time after the system is started.

### 4.1 Initial start-up

The initial start-up is carried out during the initial installation. The entire system is rinsed before guard column and separation column are installed.



#### Caution

The separation column and guard column may not be installed for the initial start-up.

Make sure that the coupling (6.2744.040) is being used instead of the columns.

Perform the following steps during the initial start-up:

#### 1 Preparing the software

- Start the PC program **MagIC Net™**.
- Open the **Equilibration** tab in MagIC Net™.
- Select (or create) a suitable method.

#### 2 Preparing the instrument

- Ensure that the eluent aspiration tubing is immersed in the eluent and that there is enough eluent in the eluent bottle.
- Ensure that the aspiration tubings for the auxiliary solutions (regeneration solution and rinsing solution) are immersed into the respective solutions and that there is enough solution in the bottles.
- Switch on the instrument.

#### 3 Starting equilibration

- In MagIC Net™, start the equilibration.



#### 4 Deaerate the high pressure pump

- Deaerate the high pressure pump(s) via the purge valve (see Chapter 3.9.2, page 32).

#### 5 Set the contact pressure of the peristaltic pump



##### Note

This work step needs to be performed only if a peristaltic pump is being used.

- If peristaltic pumps are used, set the contact pressure (see "Set flow rate", page 44).

#### 6 Rinsing the instrument without columns

- Rinse the instrument (without columns) with eluent for 5 minutes.

The instrument is now ready for the installation of the columns (see Chapter 3.17, page 53).

## 4.2 Conditioning

After the installation and after switching on the instrument, the system must be conditioned with eluent until a stable baseline is reached.



##### Note

After a change of eluent (see Chapter 5.4.2.3, page 63), the conditioning time can lengthen considerably.

### Conditioning the system

#### 1 Preparing the software



##### Caution

Ensure that the flow set is not higher than the flow permissible for the corresponding column (see column leaflet and chip data set).

- Start the PC program **MagIC Net™**.
- Open the **Equilibration** tab in MagIC Net™.

- Select (or create) a suitable method.

## 2 Preparing the instrument

- Ensure that the column is correctly mounted according to the flow direction indicated on the label (arrow must point in the direction of flow).
- Ensure that the eluent aspiration tubing is immersed in the eluent and that there is enough eluent in the eluent bottle.
- Ensure that the aspiration tubings for the auxiliary solutions (regeneration solution and rinsing solution) are immersed into the respective solutions and that there is enough solution in the bottles.

## 3 Checking leak-tightness

- In MagIC Net™, start the equilibration.
- Check all capillaries and their connections from the high pressure pump to the detector for signs of liquid escaping. If eluent escapes anywhere, tighten the corresponding pressure screw or loosen the connection, check the end of the capillary, shorten it with a capillary cutter if necessary, and restore the connection.

## 4 Conditioning the system

Rinse the system with eluent until the required stability of the baseline is attained (normally 30 minutes).

During this time, step the MSM to the next position every 10 minutes.

The instrument is now ready for measuring samples.



### 5.1.3 Operation



#### Caution

In order to avoid disturbing temperature influences, the entire system including the eluent bottle must be protected against direct sunlight.

### 5.1.4 Shutting down

If the instrument is not used for a longer period, the whole IC system (except the columns) must be rinsed salt free with methanol/ultrapure water (1:4), in order to prevent eluent salts from forming crystals which may cause subsequent damage.

#### Rinsing salt free the IC system

To rinse the system, proceed as follows:

- 1 Remove the separation column from the eluent path. Connect the connection capillaries directly with each other using a coupling (6.2744.040).
- 2 Rinse the IC system with methanol/ultrapure water (1:4) for 15 minutes.

Rinse with eluent for at least 15 minutes at starting up again and before connecting the guard column and separation column.

## 5.2 Capillary connections

### 5.2.1 Operation

All connections between injection valve, separation column and detector must be as short as possible, have a low dead volume and be completely leak-tight. The PEEK capillary after the detector must be free of blockages. Only use PEEK capillaries with an internal diameter of 0.25 mm in the high pressure range between the high pressure pump and the detector.



## 5.3 Door



### Caution

The door is made of PMMA (polymethylmetacrylate). It must never be cleaned with abrasive media or solvents.



### Caution

Never use the door as a handle.

## 5.4 Eluent

### 5.4.1 Production

The chemicals used for the production of eluents should have a degree of purity of at least "p.a.". Only ultrapure water (resistance > 18.2 MΩ\*cm) may be used for dilution (this generally applies for reagents which are used in ion chromatography).

Newly produced eluents should always be microfiltered (filter 0.45 µm).

The composition of the eluent has a crucial effect on the chromatographic analysis:

<b>Concentration</b>	An increase in the concentration generally leads to shorter retention times and faster separation, but also to higher background conductivity signal.
<b>pH</b>	pH changes result in shifts in the dissociation equilibria and hence changes in the retention times.
<b>Organic solvents</b>	The addition of an organic solvent (e.g. methanol, acetone, acetonitrile) to aqueous eluents generally accelerates lipophilic ions.

## 5.4.2 Operation

### 5.4.2.1 Supply bottle

The supply bottle with the eluent must be connected as indicated in *chapter 3.8.1, page 25*. This is above all important for eluents with volatile solvents (e.g. acetone).

Moreover, condensation must also be prevented in the eluent bottle. Drop formation can change the concentration ratio in the eluent.

In the case of very sensitive measurements, we recommend that the eluent be stirred constantly with a magnetic stirrer (e. g. the 2.801.0010 with 6.2070.000).

### 5.4.2.2 Aspiration filter

To protect the IC system against foreign particles, we recommend aspirating the eluents via a 6.2821.090 aspiration filter (9-2). This aspiration filter must be replaced should it show signs of yellow discoloration (but no later than every 3 months).

### 5.4.2.3 Changing the eluent

When changing the eluent, it must be ensured that no precipitates can occur. Solutions following one another in direct succession must therefore be miscible. If the system has to be rinsed organically, several solvents with rising or falling lipophilia must be used.

## 5.5 High pressure pump

### 5.5.1 Protection



#### Caution

The pump head is filled ex works with methanol/ultrapure water. It must be ensured that the eluent used is freely miscible with the solvent remaining in the pump head.

To protect the high pressure pump against **foreign particles**, we recommend that the eluent undergoes a **microfiltration** (filter 0.45 µm) before being aspirated via a 6.2821.090 aspiration filter (*see Chapter 5.4.2.2, page 63*).

**Salt crystals** between the piston and seal cause abrasion particles which can find their way into the eluent. These lead to contaminated valves, a rise in pressure and in extreme cases scratched pistons. It is therefore essential to ensure that **no precipitates** can occur (*see Chapter 5.4.2.3, page 63*).



### Caution

In order to spare the pump seals, the pump should not be operated dry. Therefore ensure that the eluent supply is correctly connected and that there is enough eluent in the eluent bottle each time before switching on the pump.

## 5.5.2 Maintenance



### Caution

Maintenance work on the high pressure pump may not be carried out unless the **instrument is switched off**.

### Pump head maintenance

An unstable baseline (pulsation, flow fluctuations) is in many cases the result of contaminated valves (33-2), (33-3) or defective, leaking piston seals on the high pressure pump. Proceed as follows for cleaning contaminated valves and/or replacing worn parts such as pistons, piston seal and valves:

This maintenance work should be carried out at least once a year.

### Removing the pump head

- 1 Switch off high pressure pump and wait until pressure is released.
- 2 Loosen the pressure screw on the inlet valve holder (13-6) and unscrew the pump head input capillary (13-7), the coupling (13-9), and the eluent aspiration tubing from the pump head.  
  
In the process, eluent will spill. Hold the eluent aspiration tubing up high and allow the eluent to flow back into the eluent bottle.
- 3 Unscrew the pump head outlet capillary (13-13) from the pump head.
- 4 Remove pump head from the pump housing by loosening the 4 fastening screws (13-5) using the hexagon key (6.2621.030). The main piston is on the left (viewed from the front), and the auxiliary piston is on the right.

## Cleaning/replacing the zirconium oxide piston

Clean one piston after the other as follows:

### 1 Removing the piston cartridge from the pump head

Loosen the piston cartridge with a wrench and unscrew from the pump head by hand.

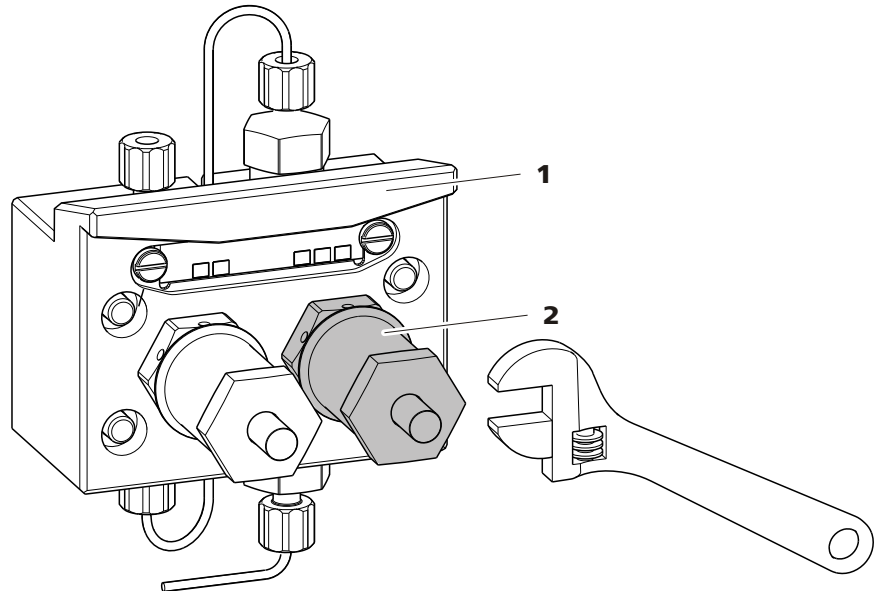

Figure 27 Pump head – removing the piston

**1** Pump head

**2** Piston cartridge

### 2 Dismantling the piston



#### Caution

On the inside of the piston cartridge there is a taut spring that can jump out of the piston cartridge if suddenly losing tension.

When opening the piston cartridge, hold pressure towards the spring and unscrew carefully.

- Loosen the screw of the piston cartridge with a wrench and unscrew carefully by hand and by holding pressure towards the taut spring.
- Remove the zirconium oxide piston and lay on a tissue.
- Remove the spring retainer, spring and the inner plastic sleeve from the piston cartridge and lay by.



- Remove the backup ring from the pump head and lay to the other parts.

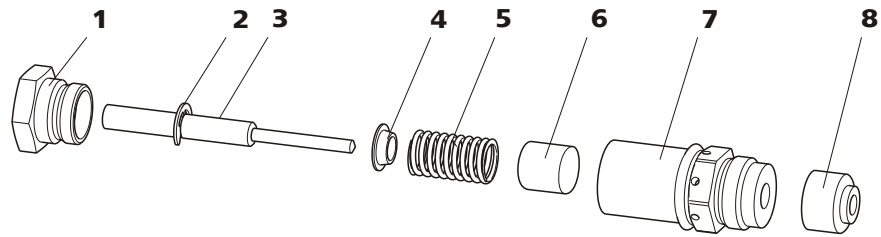

Figure 28 Components of the piston cartridge

<b>1</b>	<b>Piston cartridge screw</b>	<b>2</b>	<b>Retaining washer</b>
<b>3</b>	<b>Zirconium oxide piston with piston shaft</b> Order number: 6.2824.070	<b>4</b>	<b>Spring retainer</b>
<b>5</b>	<b>Spring</b> Order number: 6.2824.060	<b>6</b>	<b>Inner plastic sleeve</b> Protects from metallic abrasion.
<b>7</b>	<b>Piston cartridge</b>	<b>8</b>	<b>Backup ring</b>

### 3 Cleaning the components of the piston

- Clean zirconium oxide pistons contaminated by abrasion or deposits with fine abrasive cleaning powder, rinse particle free with ultrapure water and dry.  
Replace highly contaminated or scratched zirconium oxide pistons (spare part: 6.2824.070 zirconium oxide piston).
- Rinse the other parts of the piston and dry with a lint-free cloth.

### 4 Assembling the piston

- Insert the inner plastic sleeve, spring and spring retainer into the piston cartridge.
- Slide the zirconium oxide piston carefully into the piston cartridge until its tip emerges from the small opening of the piston cartridge.
- Attach screw and tighten by hand.

### Replacing the piston seal

The special tool (6.2617.010) (see Figure 29, page 67) is necessary to remove the piston seal from the pump head. It consists of two parts: a tip

for removing the old piston seal and a sleeve for inserting the new piston seal.

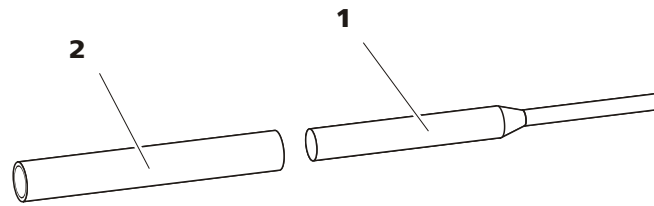

Figure 29 Tool for piston seal

**1 Pin**

Tip for removing the old piston seal.

**2 Sleeve**

Sleeve for inserting the new piston seal.



**Caution**

Screwing the special tool for the piston seal (6.2617.010) into the piston seal destroys this completely!

**1 Removing the piston seal**



**Caution**

Avoid touching the sealing surface in the pump head (13-4) with the tool.

Screw the special tool for the piston seal (29-1) with the narrow side just as far into the piston seal as the same can be removed.

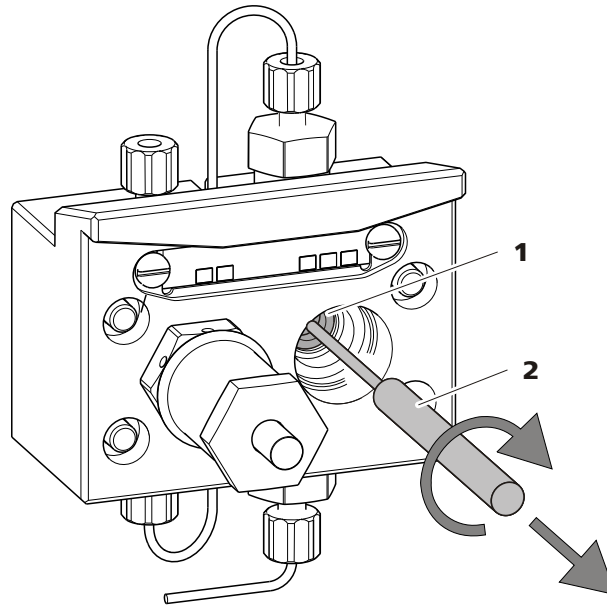

Figure 30 Removing the piston seal

- |                      |   |
|----------------------|---|
| <b>1 Piston seal</b> | <b>2 Tool for piston seal</b><br>Pin of the tool. |
|----------------------|---|

**2 Inserting the new piston seal into the tool**

Insert the new piston seal tightly by hand into the recess of the sleeve of the tool for the piston seal (29-2). The sealing springs must be visible from the outside.

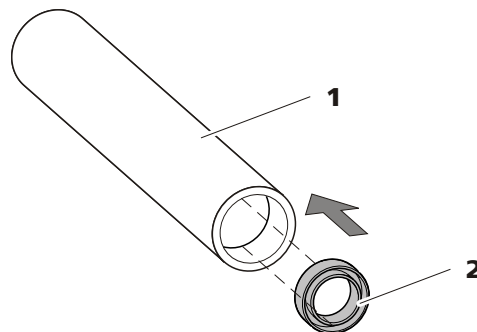

Figure 31 Inserting the piston seal into the tool

- |   |  |
|---|--|
| <b>1 Tool for piston seal (6.2617.010)</b><br>Sleeve for inserting the new piston seal. | <b>2 Piston seal</b><br>Order number: 6.2741.020 |
|---|--|

**3 Inserting the new piston seal into the pump head**

Guide the sleeve of the tool for the piston seal (29-2) with inserted piston seal into the pump head and press the seal with the wide end of the tool for the piston seal (29-1) into the pump head recess.

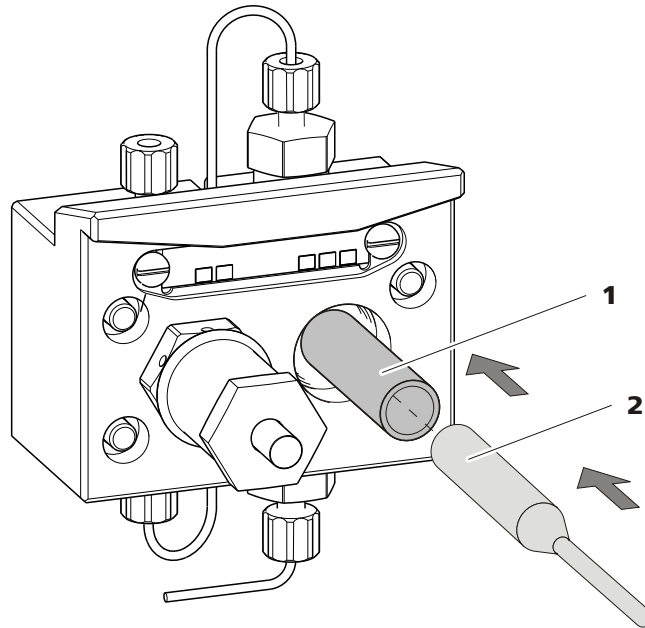

Figure 32 Inserting the piston seal into the pump head

#### 4 Replacing the piston cartridge

Screw the assembled piston cartridge back into the pump head and tighten, first by hand, then additionally by approx. 15° with a wrench.

### Cleaning the inlet valve and outlet valve

#### 1 Removing valves

- Unscrew the connection capillary for the auxiliary piston (13-1) from the outlet valve holder.
- Unscrew the holders for the inlet and outlet valves and remove the valves (33-3) and (33-2).

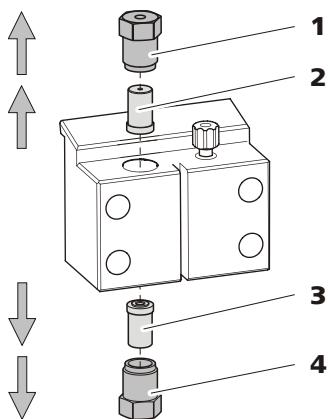

Figure 33 Removing valves

<b>1</b> Outlet valve holder	<b>2</b> Outlet valve Order number: 6.2824.160
<b>3</b> Inlet valve Order number: 6.2824.170	<b>4</b> Inlet valve holder

**2 Cleaning undissected valve**

Clean contaminated or blocked valves initially **without** dismantling them completely.

- Rinse the valve in eluent flow and counterflow direction using a spray bottle filled with ultrapure water, RBS solution or acetone.
- The rinsing effect is further increased through a short treatment (lasting for a maximum of 20 s) in an ultrasonic bath.



**Note**

Longer lasting ultrasonic baths can damage the ruby ball of the valve.

Only if this cleaning is useless, dismantle the valves separately and clean the components.

**3 Dismantling valve**

Dismantle every valve separately.



**Note**

For dismantling the valve the tool for valve cartridges (6.2617.020) is required.

- Place the valve with the seal faced downwards above the recess in the holder.
- Push the valve components out of the valve housing using the needle of the tool.

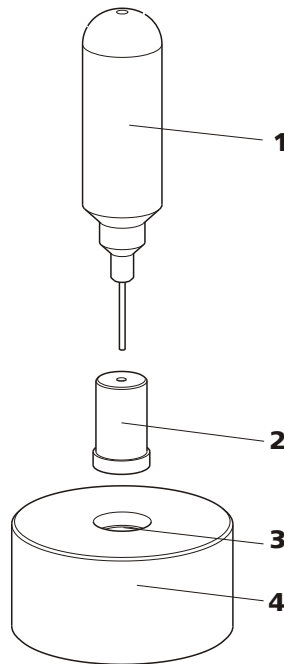

Figure 34 Dismantling valve

**1 Needle**

For pushing the valve components out of the valve housing.

**2 valve**

**3 Recess**

For collecting the valve components.

**4 Holder**

The components of the valve are collected in the recess of the holder.



**Note**

The components of the valve are very small. In order not to lose them, put the components into a dish.

- The inlet valve and the outlet valve consist of the same, just differently arranged components (see Figure 35, page 72).

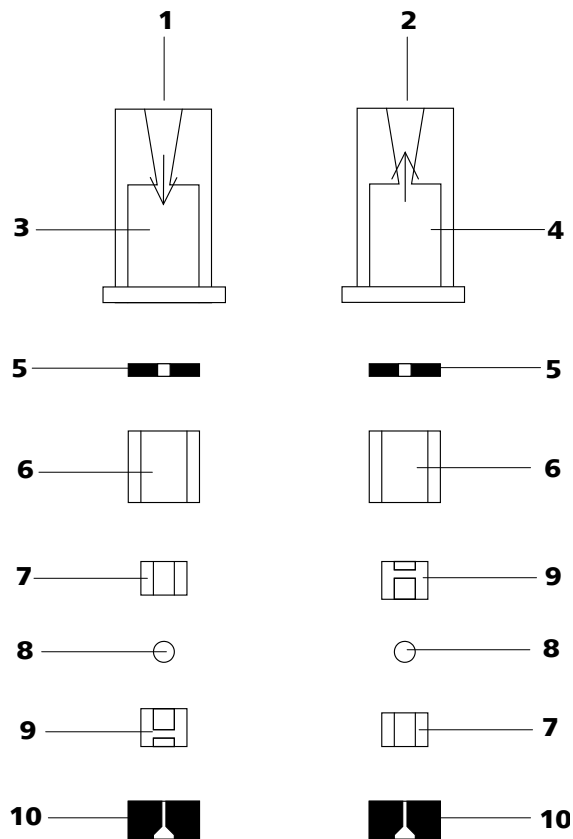

Figure 35 Components of the inlet valve and outlet valve

<b>1</b>	<b>Inlet valve (6.2824.170)</b>	<b>2</b>	<b>Outlet valve (6.2824.160)</b>
<b>3</b>	<b>Inlet valve housing</b>	<b>4</b>	<b>Outlet valve housing</b>
<b>5</b>	<b>Sealing ring (black)</b>	<b>6</b>	<b>Sleeve</b>
<b>7</b>	<b>Sapphire sleeve</b> The shiny side must point to ruby ball.	<b>8</b>	<b>Ruby ball</b>
<b>9</b>	<b>Ceramic holder for ruby ball</b>	<b>10</b>	<b>Seal</b> The larger opening must point outwards.

#### 4 Cleaning the components of the valve

Rinse the valve components with ultrapure water and/or acetone and dry with a lint-free cloth.

#### 5 Reassembling the valve

Reassemble valve components *according to figure 35, page 72*.

- Insert the seal with the larger opening faced downwards into the recess of the tool.
- Lay the other valve components above another in the correct sequence (*see Figure 35, page 72*).

- Place over the valve housing and hold it tightly.
- By tilting the tool, the valve components slide into the valve housing.
- Press the seal by hand well on the valve housing.

## 6 Checking the flow direction

Rinse the valve in the direction of the arrow on the valve housing and check whether liquid is escaping on the other end.

If this is not the case, the valve has to be dismantled again and be reassembled correctly (see Figure 35, page 72).

## 7 Inserting the valves back into the pump head



### Caution

If by mistake, the inlet valve is mounted instead of the outlet valve, an extreme pressure builds up within the working cylinder, which can destroy the piston seal!

When inserting the valves, please take into account that the liquid is being pumped through the pump head from bottom to top.

- Insert the inlet valve into the inlet valve holder the way the seal is visible.
- Screw the inlet valve holder into the bottom of the pump head and tighten with a wrench (33-4).
- Insert the outlet valve into the outlet valve holder the way the seal is visible.
- Screw the outlet valve holder into the top of the pump head and tighten with a wrench (33-1).



## Mounting the pump head



### Note

To prevent the pump head from being positioned the wrong way, it is provided with different bore hole depths for the fastening bolts, i. e. a fastening bolt is longer than all others. The bore hole with the greatest depth must therefore be assigned to the longest bolt. If this is not the case, the pump will not function perfectly.

- 1** Mount the pump head on the pump again using the four fastening screws (13-5). Firmly tighten the screws with the hexagon key (6.2621.030).
- 2** Screw connection capillaries (13-1), (13-7) and (13-13) onto the pump head again.

## 5.6 Inline filter

### 5.6.1 Maintenance

The inline filter (6.2821.120) comprises the filter housing (36-2), the filter screw (36-4) and the filter (36-3). New filters (36-3) are available under the order number 6.2821.130 (10 items).

The filters (6.2821.130) (36-3) should be changed every 3 months (more frequently at higher backpressure).

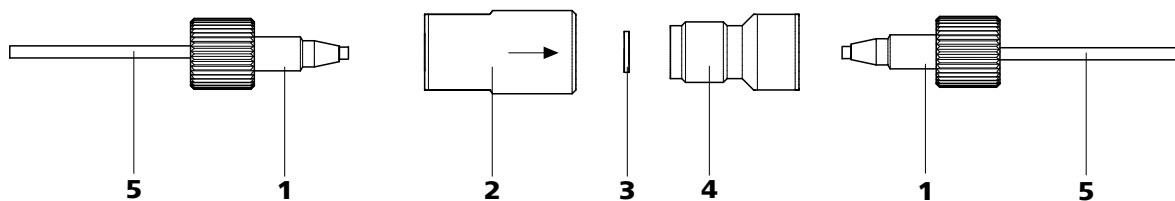

Figure 36 Change filters (of the inline filter)

**1 PEEK pressure screws, short**  
(6.2744.070)

**3 Filter (6.2821.130)**  
Packaging contains 10 items.

**5 Connection capillaries**

**2 Filter housing**  
Housing of the inline filter. Part of the 6.2821.120 accessories.

**4 Filter housing**  
Screw of the inline filter. Part of the 6.2821.120 accessories.

## Changing the filter

The flow must be stopped before changing the filter.

### 1 Removing the inline filter

- Unscrew the pressure screws (36-1) from the inline filter.

### 2 Unscrewing the filter screw

- Screw the filter screw (36-4) out of the filter housing (36-2) with the aid of two adjustable wrenches (6.2621.000).

### 3 Inserting the filter

- Remove the old filter (36-3) using tweezers.
- Place the new filter (36-3) flat in the filter housing (36-2) using tweezers.

### 4 Mounting filter screw

- Screw the filter screw (36-4) back into the filter housing (36-2) and tighten by hand. Then additionally tighten slightly with two adjustable wrenches (6.2621.000).

### 5 Remounting the inline filter

- Screw pressure screws (36-1) back onto the inline filter.

### 6 Rinsing the inline filter

- Dismantle the guard column (if present) and the separation column and replace with a coupling (6.2744.040).
- Rinse the instrument with eluent.



## 5.7 Injection valve

### 5.7.1 Protection

To prevent contamination of the injection valve, a 6.2821.120 inline filter (see Chapter 3.10, page 34) should be mounted between the high pressure pump and the pulsation damper.

## 5.8 Inline sample preparation

To protect the separation column (see Chapter 3.18, page 54) against foreign particles which can affect the separating efficiency, we recommend that all samples undergo a microfiltration (filter 0.45 µm). The ultrafiltration cell can be used for **filtration** (see manual of the *IC Equipment for Ultrafiltration*).

**Matrix-loaded** samples (e.g. blood, oil) should be prepared for the measurement by means of dialysis (see manual on the *IC Equipment for Dialysis*).

If the concentration of the sample is too high, the sample should be **diluted** before feeding (see documentation on the *IC Equipment for Sample Dilution*).

For an overview of all Metrohm inline sample preparation methods go to the following website: <http://misp.metrohm.com>

## 5.9 Rinsing the sample path

Before a new sample can be measured, the sample path must be rinsed with it so that the measuring result is not falsified by the previous sample (**Sample carry-over**).

In the case of automated sample feeding, the rinsing time should be at least 3 times the **transfer time**.

The transfer time is the time required by the sample to flow from the sample vessel to the end of the sample loop. ##NO\_MATCH##.

### Ascertaining the transfer time

To ascertain the transfer time, proceed as follows:

#### 1 Emptying the sample path

Pump air through the sample path (pump tubing, tubing connections, sample loop) for several minutes until all liquid is displaced by the air.

## 2 Aspirating the sample and measuring time

Aspirate a sample typical for the later application and use a stop watch to measure the time required by the sample to travel from the sample vessel to the end of the sample loop.

The time measured corresponds to the "transfer time". The rinsing time should be at least 3 times the transfer time.

## Checking the rinsing time

It is possible to determine whether the rinsing time is adequate via a direct measurement of the sample carry-over. Proceed as follows:

### 1 Preparing two samples

- **Sample A:** A typical sample for the application.
- **Sample B:** Ultrapure water.

### 2 Determining "Sample A"

Let "Sample A" pass through the sample path for the duration of the rinsing time, then inject and measure.

### 3 Determining "Sample B"

Let "Sample B" pass through the sample path for the duration of the rinsing time, then inject and measure.

### 4 Calculating the sample carry-over

The degree of the sample carry-over corresponds to the ratio of the peak areas of the measurement for sample B to the measurement for sample A. The lower the ratio, the lower the sample carry-over. This ratio can be modified by varying the rinsing time – thus allowing the rinsing time required for the application to be ascertained.



## 5.10 Peristaltic pump

### 5.10.1 Operation

The pumping capacity of the peristaltic pump depends on the drive speed (set via software), the contact pressure and, above all, the internal diameter of the pump tubing. Depending on the application, different pump tubings are used.



#### Caution

The service life of the pump tubings also depends on the contact pressure. Therefore fully lift the tubing cartridges by loosening the snap-action lever (**21-10**) on the right-hand side if the peristaltic pump is to be turned off for a longer period. Once set, the contact pressure remains unaffected.



#### Caution

The 6.1826.xxx pump tubings consist of PVC or PP and therefore must not be used for rinsing with solutions containing acetone. In this case, use other pump tubings or use another pump for rinsing.

### 5.10.2 Maintenance

#### 5.10.2.1 Pump tubing

The pump tubing used in the peristaltic pump is a consumable whose service life is restricted.

The LFL pump tubing with 3 stoppers is stretched in the tubing cartridge in such a way that it comes to rest between two stoppers. This results in two possible positions for the tubing cartridge. If the pump tubing should exhibit clear signs of wear, then this can be stretched a second time, in the respective alternate position.

Therefore replace the pump tubing periodically, or when used permanently approx. every 4 weeks .

#### Selecting the pump tubing

The pump tubing differs in material, diameter and hence also pumping capacity. Depending on the application, different pump tubings are used.

The following table provides information on the properties and use of the pump tubing:

Table 2 Pump tubing

Order number	Name	Material	Inner diameter	Use
6.1826.020	Pump tubing (blue/blue), 2-stopper	PVC (Tygon ST)	1.65 mm	Pump tubing for online IC instruments and automation in voltammetry
6.1826.310	Pump tubing LFL (orange/green), 3-stopper	PVC (Tygon)	0.38 mm	Pump tubing for bromate determination using the triiodide method.
6.1826.320	Pump tubing LFL (orange/yellow), 3-stopper	PVC (Tygon)	0.48 mm	For suppressor solutions, acceptor solutions for inline dialysis and for inline ultrafiltration.
6.1826.330	Pump tubing LFL (orange/white), 3-stopper	PVC (Tygon)	0.64 mm	No special applications.
6.1826.340	Pump tubing LFL (black/black), 3-stopper	PVC (Tygon)	0.76 mm	For the sample solution in inline dialysis.
6.1826.360	Pump tubing LFL (white/white), 3-stopper	PVC (Tygon)	1.02 mm	For sample transfer.
6.1826.380	Pump tubing LFL (gray/gray), 3-stopper	PVC (Tygon)	1.25 mm	For inline sample dilution.
6.1826.390	Pump tubing LFL (yellow/yellow), 3-stopper	PVC (Tygon)	1.37 mm	For the sample solution in inline ultrafiltration.

### 5.10.2.2 Pump tubing connection with filter

The 6.2821.130 filters (37-2) should be changed every 3 months, more frequently at higher backpressure.

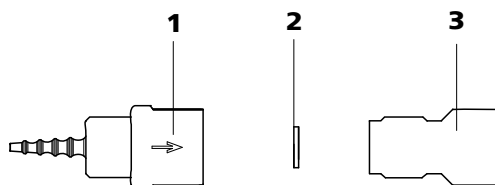

Figure 37 Pump tubing connection – Changing the filter

**1** Tubing olive

**2** Filter 6.2821.130  
Packaging contains 10 items.

**3** Filter housing

### Replacing the filter

#### 1 Unscrewing filter screw

- Screw the filter screw (37-3) out of the tubing olive (37-1) with the aid of two 6.2621.000 adjustable wrenches.

#### 2 Replacing the filter

- Remove the old filter (37-2) with tweezers.
- Place the new filter (37-2) flat in the tubing olive (37-1) with tweezers.

#### 3 Mounting filter screw

- Screw the filter screw (37-3) back into the tubing olive (37-1) and tighten by hand. Then additionally tighten with two 6.2621.000 adjustable wrenches.

## 5.11 Metrohm Suppressor Module (MSM)

### 5.11.1 Protection

To protect the suppressor against foreign particles or bacterial growth, a pump tubing connection with filter (6.2744.180) (see Figure 22, page 42) must be mounted between the peristaltic pump (see Figure 20, page 40) and the inlet capillaries of the suppressor.

### 5.11.2 Operation Suppressor



#### Note

The suppressor units must never be regenerated in the same flow direction in which the eluent is pumped. Therefore, always mount the inlet and outlet capillaries according to diagram outlined in (*see "Connecting the capillaries of the suppressor", page 47*).

The suppressor consists of 3 suppressor units, which are in rotation used for suppression – regenerated with regeneration solution – rinsed with ultrapure water. In order to record every new chromatogram under comparable conditions, you should normally work with a freshly regenerated suppressor unit.



#### Caution

The suppressor must never be switched over in a dry state, as there is a risk of jamming. If the suppressor is in a dry state, it must be rinsed for at least 5 minutes before it may be switched over.



#### Caution

In the case of reduced capacity or high backpressure, the suppressor must be regenerated (*see Chapter 5.11.3.2, page 82*), cleaned (*see Chapter 5.11.3.3, page 84*) or replaced (*see Chapter 5.11.3.4, page 85*).



## 5.11.3 Maintenance

### 5.11.3.1 Parts of the suppressor

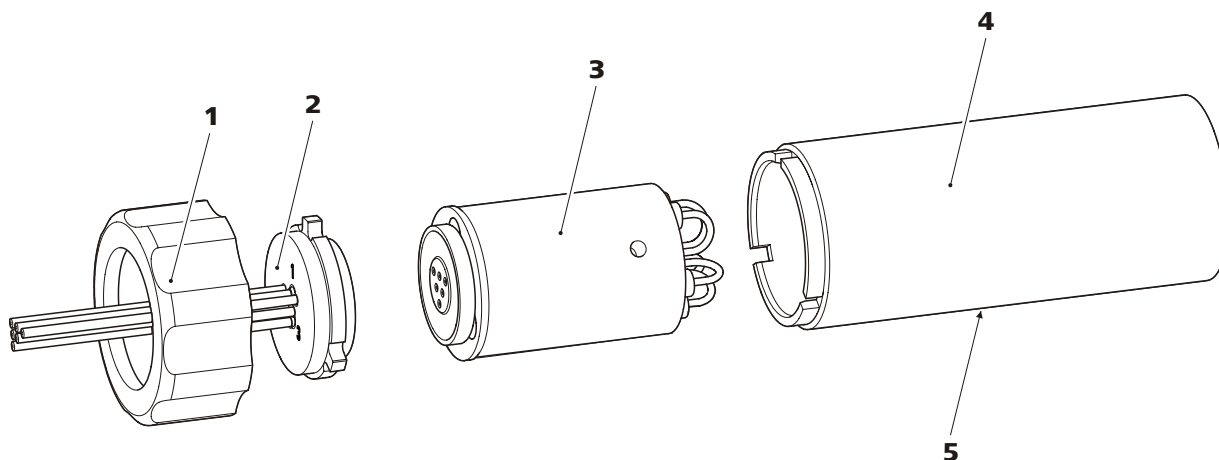

Figure 38 Parts of the suppressor

<b>1</b>	<b>Union nut</b>	<b>2</b>	<b>Connecting piece (6.2832.010)</b>
<b>3</b>	<b>Rotor</b>	<b>4</b>	<b>Housing</b>
<b>5</b>	<b>Slot in the housing</b>		

### 5.11.3.2 Regenerating the suppressor

If the suppressor units are loaded for a longer period with certain heavy metals (e.g. iron) or organic impurities, these can no longer be completely removed with the standard regeneration solution. The capacity of the suppressor units is consequently affected, which can result in reduced phosphate sensitivity in less serious cases and a significant rise in the baseline in more serious cases.

If such capacity problems occur at one or more positions, all suppressor units must be regenerated with one of the following solutions:

- **Contamination with heavy metals:**  
1 mol/L H<sub>2</sub>SO<sub>4</sub> + 0.1 mol/L oxalic acid
- **Contamination with organic cationic complexing agents:**  
0.1 mol/L H<sub>2</sub>SO<sub>4</sub> / 0.1 mol/L oxalic acid / acetone 5%
- **Severe contamination with organic substances:**  
0.2 mol/L H<sub>2</sub>SO<sub>4</sub> / acetone ≥ 20%



#### Caution

The pump tubings made of PVC must not be used for rinsing with solutions containing organic solvents.

We recommend to use the high pressure pump for regeneration.

## Regenerating the suppressor

### 1 Disconnecting the suppressor from the IC system

- Disconnect the capillaries of the suppressor labeled with *regenerant* and *rinsing solution* from the IC system.

### 2 Connecting the suppressor to the high pressure pump

- Connect the inlet capillary for the regeneration solution (labeled with *regenerant*) to the outlet of the high pressure pump with the aid of a coupling (6.2744.040)

### 3 Regenerating the suppressor

- Regenerate the first suppressor unit for about 15 minutes.
- In the software, use the **Step** command to switch to the second suppressor unit and regenerate this for about 15 minutes.
- In the software, use the **Step** command to switch to the third suppressor unit and regenerate this for about 15 minutes.

### 4 Rinsing the suppressor

After regeneration, the three suppressor units must be rinsed with degassed ultra pure water for about 15 minutes.

- Remove the inlet capillary for the regeneration solution (labeled with *regenerant*) from the outlet of the high pressure pump.
- Connect the inlet capillary for the rinsing solution (labeled with *rinsing solution*) to the outlet of the high pressure pump with the aid of a coupling (6.2744.040).
- Rinse the first suppression unit with degassed ultra pure water for about 15 minutes.
- In the software, use the **Step** command to switch to the second suppressor unit and rinse this for about 15 minutes.
- In the software, use the **Step** command to switch to the third suppressor unit and rinse this for about 15 minutes.

### 5 Connect the suppressor to the IC system

- Reconnect the capillaries labeled *regenerant* and *rinsing solution* to the IC system.



### 5.11.3.3 Cleaning the suppressor

In the following cases, it may be necessary to clean the suppressor:

- Increased backpressure onto the connection tubings of the suppressor..
- Blockage of the suppressor which cannot be eliminated (solutions can no longer be pumped through the suppressor).
- Jamming of the suppressor which cannot be eliminated (suppressor can no longer be switched over).

#### Cleaning the suppressor

Clean the suppressor as follows:

##### 1 Disconnecting the suppressor from the IC system

- Switch off the instrument.
- Disconnect all capillaries of the suppressor from the IC system.

##### 2 Dismantling the suppressor

- Unscrew union nut (38-1) from the housing (38-4).
- Pull the connecting piece (38-2) and the rotor (38-3) out of the housing.

The connecting piece and the rotor normally stick to one another – if this is not the case: Take a sharp object, insert it into the slot of the housing (38-5) and pull out the rotor in this way.

- Detach the connecting piece from the rotor.

##### 3 Cleaning the inlets and outlets

- Connect in turn each of the 6 PTFE capillaries fastened on the connecting piece (38-2) to the high pressure pump (see Chapter 3.9, page 29) and pump through ultrapure water.
- Check whether solution emerges at the connecting piece. If one of the inlets or outlets remains blocked, the connecting piece must be replaced (order number 6.2835.010) (see "Replacing parts of the suppressor", page 86).

##### 4 Cleaning the rotor

- Clean the surface of the rotor (38-3) with ethanol using a lint-free cloth.

## 5 Inserting the rotor



### Caution

An incorrectly inserted rotor can be **destroyed** during start-up.

- Insert the rotor (38-3) into the housing (38-4) in such a way that the tubing connections on the rear of rotor fit into the corresponding recesses inside the housing and one of the three holes of the rotor is visible from below in the slot of the housing (38-5).
- If the rotor is correctly inserted, its sealing surface will be approx. 4 mm within the housing. If this is not the case, the rotor must be moved into the right position from below using a sharp object.

## 6 Cleaning the connecting piece

- Clean the surface of the connecting piece (38-2) with ethanol using a lint-free cloth.

## 7 Inserting the connecting piece

- Insert the connecting piece (38-2) into the housing in such a way that the connector 1 is on top and the three pins of the connecting piece fit into the corresponding recesses on the housing.
- Reattach the union nut (38-1) onto the housing and tighten by hand (do not use a tool).

## 8 Connecting and conditioning the suppressor

- Reconnect the suppressor to the IC system.
- Before switching the suppressor over for the first time, rinse each of the three suppressor units with solution for 5 minutes.

### 5.11.3.4 Replacing parts of the suppressor

In the following cases, it might be necessary to replace parts of the suppressor:

- Loss of suppression capacity which cannot be eliminated (reduced phosphate sensitivity and/or significant rise in the baseline).
- Blockage of the suppressor which cannot be eliminated (solutions can no longer be pumped through the suppressor).

Both the rotor and the connecting piece can be replaced.



## Replacing parts of the suppressor

Replace the parts of the suppressor as follows:

### 1 Disconnecting the suppressor from the IC system

- Switch off the instrument.
- Disconnect all capillaries of the suppressor from the IC system.

### 2 Dismantling the suppressor

- Unscrew union nut (38-1) from the housing (38-4).
- Pull the connecting piece (38-2) and the rotor (38-3) out of the housing.

The connecting piece and the rotor normally stick to one another – if this is not the case: Take a sharp object, insert it into the slot of the housing (38-5) and pull out the rotor in this way.

- Detach the connecting piece from the rotor.

### 3 Cleaning the new rotor

- Clean the surface of the new rotor (38-3) with ethanol using a lint-free cloth.

### 4 Inserting the new rotor



#### Caution

An incorrectly inserted rotor can be **destroyed** during start-up.

- Insert the new rotor (38-3) into the housing (38-4) in such a way that the tubing connections on the rear of rotor fit into the corresponding recesses inside the housing and one of the three holes of the rotor is visible from below in the slot of the housing (38-5).
- If the rotor is correctly inserted, its sealing surface will be approx. 4 mm within the housing. If this is not the case, the rotor must be moved into the right position from below using a sharp object.

### 5 Cleaning the new connecting piece

- Clean the surface of the new connecting piece (38-2) with ethanol using a lint-free cloth.

**6 Inserting the new connecting piece**

- Insert the connecting piece (38-2) into the housing (38-4) in such a way that the connector 1 is on top and the three pins of the connecting piece fit into the corresponding recesses on the housing.
- Reattach the union nut (38-1) onto the coupling and tighten by hand..

**7 Connecting and conditioning the suppressor**

- Reconnect all capillaries of the suppressor to the IC system.
- Before switching the suppressor over for the first time, rinse the three suppressor units with solution for 5 minutes.

**5.12 Metrohm CO<sub>2</sub> Suppressor (MCS)****5.12.1 Replacing the CO<sub>2</sub> adsorption cartridge**

The 6.2837.000 CO<sub>2</sub> adsorption cartridge (26-4) must be replaced regularly. This is because of blockages and losses in capacity.

**Jamming**

Moisture can block the CO<sub>2</sub> adsorption cartridge. This is revealed by a change in color of the cartridge material (the orange part becomes colorless). As the air flow is reduced, the vacuum becomes lower. To protect the CO<sub>2</sub> adsorption cartridge, an H<sub>2</sub>O adsorption cartridge (26-7) is installed upstream. Regular regeneration (see Chapter 5.12.2, page 87) of the H<sub>2</sub>O adsorption cartridge extends the service life of the CO<sub>2</sub> adsorption cartridge.

**Capacity loss**

The adsorption capacity of the CO<sub>2</sub> adsorption cartridge is limited. Depending on the period of operation and laboratory environment, the adsorption capacity will diminish over time. This is manifested in a rising baseline (as more CO<sub>2</sub> reaches the detector).

**5.12.2 Regenerating the H<sub>2</sub>O adsorption cartridge**

The function of the H<sub>2</sub>O adsorption cartridge is to protect the CO<sub>2</sub> adsorption cartridge against moisture. The service life of the H<sub>2</sub>O adsorption cartridge depends on the moisture content of the ambient air. Moisture reduces the capacity of the H<sub>2</sub>O adsorption cartridge (which can be observed by a change in color). Before the color changes in the entire filling material (from orange to colorless, with Fluka Order No. 94098), the H<sub>2</sub>O adsorption cartridge should be regenerated (see leaflet). The filling material is replaced during regeneration:



- 1 Allow material to dry loose (not in cartridge) at 140 °C overnight and refill. Or dispose of the old material, and fill with new material.
- 2 Cover the packed material with cotton.

## 5.13 Separation column

### 5.13.1 Separating efficiency

Which analysis quality can be attained, depends to a great extent on the separating efficiency of the separation column used. The separating efficiency of the selected separation column must be sufficient for the analysis problems present. If difficulties occur, you should always first check the quality of the separation column by recording a standard chromatogram.

You can find detailed information on the separation columns available from Metrohm in the leaflet provided along with your separation column, in the **Metrohm IC-Column Program** (available via your Metrohm agent) or in the Internet at <http://www.metrohm.com> in the product area Ion chromatography. You can request free information on special IC applications in the corresponding "**Application Bulletins**" or "**Application Notes**", which are available in the Internet at <http://www.metrohm.com> in the Applications area or via the Metrohm agent responsible.

### 5.13.2 Protection

To protect the separation column against foreign particles, which can affect the separating efficiency, we recommend that both the eluent and the samples undergo a microfiltration (filter 0.45 µm) before being aspirated via the aspiration filter (6.2821.090).

We recommend always to use a guard column (*see Chapter 3.17, page 53*). This protects the separation column and considerably increases its service life. Information regarding which guard column is suitable for your separation column can be found in the **Metrohm IC Column Program** (which is available from your Metrohm agent), the leaflet provided along with your separation column, the product information on the separation column at <http://www.metrohm.com> (product area Ion Chromatography) or obtained directly from your agent.

The pulsation absorber (*see Chapter 3.11, page 35*) must be installed in order to protect the column material from pressure concussion caused by injection.

### 5.13.3 Storage

Always store the separation columns sealed and filled according to the data of the column manufacturer when not using them.

### 5.13.4 Regeneration



#### Note

The regeneration is considered as the last measure, and not to be carried out regularly.

If the separating properties of the column have deteriorated, the column can be regenerated according to the specifications of the column manufacturer. In the case of separation columns available from Metrohm, the specification for regeneration can be found on the leaflet provided along with each column.

## 5.14 Quality Management and validation with Metrohm

### Quality Management

Metrohm offers you comprehensive support in implementing quality management measures for instruments and software. Further information on this can be found in the brochure «**Quality Management with Metrohm**» available from your local Metrohm agent.

### Validation

Please contact your local Metrohm agent for support in validating instruments and software. Here you can also obtain validation documentation to provide help for carrying out the **Installation Qualification** (IQ) and the **Operational Qualification** (OQ). IQ and OQ are also offered as a service by the Metrohm agents. In addition, various application bulletins are also available on the subject, which also contain **Standard Operating Procedures** (SOP) for testing analytical measuring instruments for reproducibility and correctness.

### Maintenance

Electronic and mechanical functional groups in Metrohm instruments can and should be checked as part of regular maintenance by specialist personnel from Metrohm. Please ask your local Metrohm agent regarding the precise terms and conditions involved in concluding a corresponding maintenance agreement.



**Note**

---

You can find information on the subjects of quality management, validation and maintenance as well as an overview of the documents currently available at [www.metrohm.com/com/](http://www.metrohm.com/com/) under **Support**.

## 6 Troubleshooting

### 6.1 Problems and their solutions

<b>Problem</b>	<b>Cause</b>	<b>Remedy</b>
<b>Marked drop in pressure</b>	<i>Leak in the system.</i>	Check all capillary connections and seal leaks, if necessary ( <i>see Chapter 3.5, page 17</i> ).
	<i>Inline filter (6.2821.120) blocked.</i>	Replace the filter (6.2821.130) ( <i>see Chapter 5.6, page 74</i> ).
	<i>Suppressor – blocked.</i>	<ul style="list-style-type: none"> <li>Regenerate the suppressor (<i>see Chapter 5.11.3.2, page 82</i>).</li> </ul> <p>Note: 6.2821.180 pump tubing connection with filter must be used.</p>
	<i>Guard column – blocked.</i>	Replace guard column ( <i>see Chapter 3.17, page 53</i> ).
	<i>Separation column – blocked.</i>	<ul style="list-style-type: none"> <li>Regenerate separation column (<i>see Chapter 5.13.4, page 89</i>).</li> <li>Replace separation column (<i>see "Connecting and rinsing the separation column", page 55</i>).</li> </ul> <p>Note: Samples should always be microfiltered (<i>see Chapter 5.8, page 76</i>).</p>
	<i>Injection valve – valve blocked.</i>	Have the valve cleaned (by Metrohm service technicians).
<b>Drift of the baseline</b>	<i>Leak in the system.</i>	Check all capillary connections and seal leaks, if necessary ( <i>see Chapter 3.5, page 17</i> ).
	<i>Eluent – Evaporation of the organic solvent in the eluent.</i>	<ul style="list-style-type: none"> <li>Check the eluent bottle attachment (<i>see Figure 10, page 27</i>).</li> <li>Stir the eluent.</li> </ul>
<b>Peak areas lower than expected</b>	<i>Sample – leak in the sample path.</i>	Check the sample path.
	<i>Sample – blockage in the sample path.</i>	Check the sample path.
	<i>Sample – sample loop not (completely) filled.</i>	Prolong the sample transfer time.



<b>Problem</b>	<b>Cause</b>	<b>Remedy</b>
	<i>MCS – not connected.</i>	Connect the MCS.
<b>Peristaltic pump – insufficient or no delivery rate</b>	<i>Peristaltic pump – contact pressure too weak.</i>	Correctly set contact pressure (see "Set flow rate", page 44).
	<i>Peristaltic pump – filter blocked.</i>	Replace the filter (see Chapter 5.10.2.2, page 79).
	<i>Peristaltic pump – pump tubing defective.</i>	Replace pump tubing (see Chapter 5.10.2.1, page 78).
<b>Very noisy baseline</b>	<i>High pressure pump – contaminated pump valves.</i>	Clean pump valves (see Chapter 5.5.2, page 64).
	<i>Eluent – Leak in the eluent path.</i>	Check the eluent path.
	<i>Eluent – Blockage in the eluent path.</i>	Check the eluent path.
	<i>High pressure pump – defective piston seals.</i>	Replace (see Chapter 5.5.2, page 64) piston seals .
	<i>MCS – CO<sub>2</sub> adsorption cartridge exhausted.</i>	Replace CO <sub>2</sub> adsorption cartridge (see Chapter 5.12.1, page 87).
	<i>Pulsation absorber not connected.</i>	Connect pulsation absorber (see Chapter 3.11, page 35).
	<i>Pulsation absorber not connected. or defective.</i>	Connect pulsation absorber (see Chapter 3.11, page 35). or replace it.
	<i>MCS – vacuum pump defective.</i>	Contact the Metrohm Service.
<b>Background conductivity too high</b>	<i>Suppressor – not connected.</i>	Connect the suppressor (see Chapter 3.14.1, page 45).
	<i>MCS – not connected.</i>	Connect the MCS.
	<i>Incorrect eluent.</i>	Change the eluent (see Chapter 5.4.2.3, Page 63).
	<i>Suppressor – regeneration or rinsing solution flow problems.</i>	Check the flow of the regeneration solution and the rinsing solution.

<b>Problem</b>	<b>Cause</b>	<b>Remedy</b>
<b>Data of the separation column cannot be read.</b>	<i>Column chip contaminated.</i>	Clean the contact surfaces of the column chip (with alcohol).
	<i>Column chip defective.</i>	<ol style="list-style-type: none"> <li>1. Save column configuration in MagIC Net™.</li> <li>2. Notify Metrohm Service.</li> </ol>
<b>Individual peaks greater than expected</b>	<i>Sample – carry-over of the samples from previous measurement.</i>	Rinse system longer between two samples.
<b>Poor reproducibility of the retention times</b>	<i>Eluent – Leak in the eluent path.</i>	Check the eluent path.
	<i>Eluent – Blockage in the eluent path.</i>	Check the eluent path.
	<i>Eluent – Gas bubbles in the eluent.</i>	<ul style="list-style-type: none"> <li>▪ Deaerate the high pressure pump (see Chapter 3.9.2, page 32).</li> </ul>
<b>Suppressor – No (or insufficient) pumping of regeneration or rinsing solution</b>	<i>Leak in the system.</i>	Check connections.
	<i>Peristaltic pump – contact pressure too weak.</i>	Correctly set contact pressure (see "Set the contact pressure", page 44).
	<i>Peristaltic pump – filter blocked .</i>	Replace the filter (see "Replacing the filter", page 80).
	<i>Suppressor – backpressure too high.</i>	Clean the suppressor (see Chapter 5.11.3.3, page 84) or replace parts (see Chapter 5.11.3.4, page 85).
	<i>Peristaltic pump – pump tubing defective.</i>	Replace pump tubing.
<b>Chromatograms have poor resolution</b>	<i>Separation column – diminished separating efficiency.</i>	<ul style="list-style-type: none"> <li>▪ Regenerate separation column (see Chapter 5.13.4, page 89).</li> <li>▪ Replace separation column (see "Connecting and rinsing the separation column", page 55).</li> </ul>
<b>Extreme spread of the peaks in the chromatogram. Splitting (dual peaks)</b>	<i>Capillary connections – dead volume in the system.</i>	Check connections (see Chapter 3.5, page 17) (use PEEK capillaries with an internal diameter of 0.25 mm between the injection valve and detector).
	<i>Guard column – diminished performance.</i>	<ul style="list-style-type: none"> <li>▪ Replace guard column (see Chapter 3.17, page 53).</li> </ul>



<b>Problem</b>	<b>Cause</b>	<b>Remedy</b>
	<i>Separation column – dead volume at column head.</i>	<ul style="list-style-type: none"> <li>▪ Install the separation column in reverse flow direction (if permitted by the leaflet) and rinse into a beaker.</li> <li>▪ Replace separation column (see "Connecting and rinsing the separation column", page 55).</li> </ul>
<b>Greater rise in the baseline</b>	<i>Suppressor – reduced capacity.</i>	Regenerate the suppressor (see Chapter 5.11.3.2, page 82).
<b>Precision problems - significant scattering of the measured values</b>	<i>Injection valve – sample loop.</i>	Check installation of the sample loop (see Chapter 3.12.1, page 36).
	<i>Sample – rinsing volume too low.</i>	Increase rinsing time (see Chapter 5.9, page 76).
	<i>Injection valve – defective.</i>	Request Metrohm Service.
	<i>MCS – vacuum too low.</i>	<ul style="list-style-type: none"> <li>▪ Check connectors. If they are ok:</li> <li>▪ Contact the Metrohm Service.</li> </ul>
<b>Unexpected change to the retention times in the chromatograms</b>	<i>Separation column – diminished separating efficiency.</i>	<ul style="list-style-type: none"> <li>▪ Regenerate separation column (see Chapter 5.13.4, page 89).</li> <li>▪ Replace separation column (see "Connecting and rinsing the separation column", page 55).</li> </ul>
	<i>High pressure pump – defective.</i>	Request Metrohm Service.

## 7 Technical specifications

### 7.1 Reference conditions

The technical data listed in this Chapter refers to the following reference conditions:

<i>Ambient temperature</i>	+25 °C (± 3 °C)
<i>Instrument status</i>	> 40 minutes in operation (equilibrated)

### 7.2 Instrument

<i>IC system</i>	<ul style="list-style-type: none"> <li>▪ Metal-free IC system</li> <li>▪ Compact system with modular design</li> </ul>
<i>Material</i>	Painted polyurethane hard foam without CFCs, fire class V0
<i>Operating pressure range</i>	<ul style="list-style-type: none"> <li>▪ 0...50 MPa (500 bar) high pressure pump</li> <li>▪ 0...35 MPa (350 bar) standard-PEEK system</li> </ul>
<i>Intelligent components</i>	iPump, iDetector, iColumn, intelligent Dosino, MagIC Net

### 7.3 Leak sensor

<i>Type</i>	Electronic, no calibration necessary
-------------	--------------------------------------

### 7.4 Ambient conditions

<i>Operation</i>	
<i>Ambient temperature</i>	+5...+45 °C
<i>Humidity</i>	20...80 % relative humidity
<i>Storage</i>	
<i>Ambient temperature</i>	-20...+70 °C
<i>Transport</i>	
<i>Ambient temperature</i>	-40...+70 °C



## 7.5 Housing

### Dimensions

<i>Width</i>	302 mm
<i>Height</i>	562 mm
<i>Depth</i>	368 mm

*Material of base tray, housing and covering plate* Polyurethane hard foam (PUR) with flame retardation for fire class UL94V0, CFC-free, coated

### Operating elements

<i>Indicators</i>	LED for power display
<i>On/Off switch</i>	On the rear panel of the instrument

## 7.6 High pressure pump

<i>Type</i>	<ul style="list-style-type: none"> <li>▪ Serial dual-piston pump</li> <li>▪ Intelligent pump head recognition</li> <li>▪ Chemically inert</li> <li>▪ Metal-free pump heads</li> <li>▪ Materials in contact with eluent: PEEK, ZrO<sub>2</sub>, PTFE/PE</li> <li>▪ Self-optimizing flow and pressure</li> </ul>
-------------	--

### Flow rate

<i>Adjustable flow range</i>	0.001...20.0 mL/min
<i>Flow increment</i>	1 µL/min
<i>Reproducibility of the eluent flow</i>	< 0.1 % deviation

### Pressure range

<i>Pump</i>	0...50.0 MPa (0...500 bar)
<i>Pump head</i>	0...35.0 MPa (0...350 bar) (applies for the standard PEEK pump head)
<i>Residual pulsation</i>	< 1 %

### Safety shutdown

<i>Function</i>	Automatic shutdown upon reaching the pressure limit values
<i>Maximum pressure limit</i>	<ul style="list-style-type: none"> <li>▪ Adjustable from 0.1...50 MPa (1...500 bar)</li> </ul>

*Minimum pressure limit*

- The pump is automatically shut down at the first piston stroke above the maximum limit value
- Adjustable from 0...49 MPa (0...490 bar)
- The shutdown mechanism is inactive at 0 MPa
- The shutdown mechanism only becomes active 2 minutes after system start
- The pump is automatically shut down after 3 piston strokes below the minimum pressure limit

## 7.7 Injection valve

<i>Actuator time</i>	typ.100 ms
<i>Max. operating pressure</i>	35 MPa (350 bar)
<i>Material</i>	PEEK

## 7.8 Peristaltic pump

<i>Type</i>	2-channel peristaltic pump
<i>Rotating direction</i>	Counterclockwise/Clockwise rotation
<i>Rotational speed</i>	0...42 rpm in 7 stages at 6 rpm.
<i>Pumping properties</i>	0.3 mL/min at 18 rpm; with 6.1826.320 standard pump tubing.
<i>Material of pump tubings</i>	recommended: Tygon Long Flex Life

## 7.9 Metrohm Suppressor Module (MSM)

<i>Resistance to solvents</i>	100 % no restriction
<i>Switching time</i>	typ.100 ms



## 7.10 Metrohm CO<sub>2</sub> Suppressor (MCS)

<i>Material</i>	fluoropolymer
<i>Resistance to solvents</i>	No restriction (apart from PFC)
<i>Vacuum</i>	
<i>Working area</i>	Microprocessor-controlled / stabilized
<i>Build-up time after start</i>	< 30 s
<i>Capillary volume</i>	400 µL
<i>Recommended flow range</i>	0.1...1.0 mL

## 7.11 Mains connection

<i>Required voltage</i>	100...240 V ± 10 % (auto-sensing)
<i>Required frequency</i>	50...60 Hz ± 3 (auto-sensing)
<i>Power consumption</i>	<ul style="list-style-type: none"> <li>▪ 65 W for typical analysis application</li> <li>▪ 25 W standby (conductivity detector to 40 °C)</li> </ul>
<i>Power supply unit</i>	<ul style="list-style-type: none"> <li>▪ Up to 300 W maximum, electronically monitored</li> <li>▪ internal fuse 3.15 A</li> </ul>

## 7.12 Interfaces

<i>USB</i>	
<i>Input</i>	1 USB upstream, type B (for connection to the PC)
<i>Output</i>	2 USB downstream, type A
<i>MSB</i>	2 MSB MiniDin 8-pin (female) (for Dosino, stirrer, remote lines, ...)



### Caution

When connecting an instrument to the MSB connector you **must** switch off the 882 Compact IC plus.

<i>Detector</i>	1 DSUB-15-pin high density (female)
<i>Column recognition</i>	for an intelligent column

<i>Leak sensor</i>	1 jack plug
<i>Further connections</i>	
<i>Auxiliary</i>	1 DSUB 15-pin (female)
<i>Service</i>	1 DSUB 15-pin (female)

### 7.13 Safety specification

<i>Design / Test</i>	<ul style="list-style-type: none"> <li>▪ EN/IEC 61010-1</li> <li>▪ UL 61010-1</li> <li>▪ CSA-C22.2 No. 61010-1</li> <li>▪ Protection class I</li> </ul>
----------------------	---

### 7.14 Electromagnetic compatibility (EMC)

<i>Emission</i>	<ul style="list-style-type: none"> <li>▪ EN/IEC 61326-1</li> <li>▪ EN/IEC 61000-6-3</li> <li>▪ EN 55022 / CISPR 22</li> <li>▪ EN/IEC 61000-3-2</li> <li>▪ EN/IEC 61000-3-3</li> </ul>
<i>Immunity</i>	<ul style="list-style-type: none"> <li>▪ EN/IEC 61326-1</li> <li>▪ EN/IEC 61000-6-2</li> <li>▪ EN/IEC 61000-4-2</li> <li>▪ EN/IEC 61000-4-3</li> <li>▪ EN/IEC 61000-4-4</li> <li>▪ EN/IEC 61000-4-5</li> <li>▪ EN/IEC 61000-4-6</li> <li>▪ EN/IEC 61000-4-8</li> <li>▪ EN/IEC 61000-4-11</li> <li>▪ EN/IEC 61000-4-14</li> <li>▪ NAMUR</li> </ul>



## **7.15 Weight**

*Weight* 19.7 kg (without accessories)

## 8 Conformity and warranty

### 8.1 Declaration of Conformity

This is to certify the conformity to the standard specifications for electrical appliances and accessories, as well as to the standard specifications for security and to system validation issued by the manufacturing company.

*Name of commodity*

---

#### **882 Compact IC plus**

The 882 Compact IC plus is an intelligent ion chromatograph in a compact design for the determination of anions, cations or polar substances.

---

This instrument has been built and has undergone final type testing according to the standards:

*Electromagnetic compatibility*

Emission: EN/IEC 61326-1: 2006, EN/IEC 61000-6-3: 2004, EN 55022 / CISPR 22: 2006, EN/IEC 61000-3-2: 2006, EN/IEC 61000-3-3: 2005

Immunity: EN/IEC 61326-1: 2006, EN/IEC 61000-6-2: 2005, EN/IEC 61000-4-2: 2001, EN/IEC 61000-4-3: 2002, EN/IEC 61000-4-4: 2004, EN/IEC 61000-4-5: 2001, EN/IEC 61000-4-6: 2001, EN/IEC 61000-4-8: 2001, EN/IEC 61000-4-11: 2004, EN/IEC 61000-4-14: 2004, NAMUR: 2004

*Safety specifications*

EN/IEC 61010-1: 2001, UL 61010-1: 2004, CSA-C22.2 No. 61010-1: 2004, protection class I



This instrument meets the requirements of the CE mark as contained in the EU directives 2006/95/EC (LVD), 2004/108/EC (EMC). It fulfils the following specifications:

EN 61326-1 Electrical equipment for measurement, control and laboratory use – EMC requirements

EN 61010-1 Safety requirements for electrical equipment for measurement, control and laboratory use



*Manufacturer*

This instrument meets the requirements of the ETL Listed Mark for the North American market. It conforms to the electrical safety standards UL 61010-1 and CSA-C22.2 No. 61010-1. This product is listed in Intertek's Directory of Listed Products.

Metrohm Ltd., CH-9101 Herisau/Switzerland

Metrohm Ltd. is holder of the SQS-certificate ISO 9001:2000 Quality management system for development, production and sales of instruments and accessories for ion analysis.

Herisau, 27 October, 2008

D. Strohm

Vice President, Head of R&D

Ch. Buchmann

Vice President, Head of Production

Responsible for Quality Assurance

## 8.2 Quality Management Principles

Metrohm Ltd. holds the ISO 9001:2000 Certificate, registration number 10872-02, issued by SQS (Swiss Association for Quality and Management Systems). Internal and external audits are carried out periodically to assure that the standards defined by Metrohm's QM Manual are maintained.

The steps involved in the design, manufacture and servicing of instruments are fully documented and the resulting reports are archived for ten years. The development of software for PCs and instruments is also duly documented and the documents and source codes are archived. Both remain the possession of Metrohm. A non-disclosure agreement may be asked to be provided by those requiring access to them.

The implementation of the ISO 9001:2000 quality management system is described in Metrohm's QM Manual, which comprises detailed instructions on the following fields of activity:

### **Instrument development**

The organization of the instrument design, its planning and the intermediate controls are fully documented and traceable. Laboratory testing accompanies all phases of instrument development.

### **Software development**

Software development occurs in terms of the software life cycle. Tests are performed to detect programming errors and to assess the program's functionality in a laboratory environment.

### **Components**

All components used in the Metrohm instruments have to satisfy the quality standards that are defined and implemented for our products. Suppliers of components are audited by Metrohm as the need arises.

### **Manufacture**

The measures put into practice in the production of our instruments guarantee a constant quality standard. Production planning and manufacturing procedures, maintenance of production means and testing of components, intermediate and finished products are prescribed.

### **Customer support and service**

Customer support involves all phases of instrument acquisition and use by the customer, i.e. consulting to define the adequate equipment for the analytical problem at hand, delivery of the equipment, user manuals, training, after-sales service and processing of customer complaints. The Metrohm service organization is equipped to support customers in implementing standards such as GLP, GMP, ISO 900X, in performing Operational Qualification and Performance Verification of the system components or in carrying out the System Validation for the quantitative determination of a substance in a given matrix.

## **8.3 Warranty (guarantee)**

Metrohm guarantees that the deliveries and services it provides are free from material, design or manufacturing errors. The warranty period is 36 months from the day of delivery; for day and night operation it is 18 months. The warranty remains valid on condition that the service is provided by an authorized Metrohm service organization.

Glass breakage is excluded from the warranty for electrodes and other glassware. The warranty for the accuracy corresponds to the technical specifications given in this manual. For components from third parties that make up a considerable part of our instrument, the manufacturer's warranty provisions apply. Warranty claims cannot be pursued if the Customer has not complied with the obligations to make payment on time.

During the warranty period Metrohm undertakes, at its own choice, to either repair at its own premises, free of charge, any instruments that can be shown to be faulty or to replace them. Transport costs are to the Customer's account.



Faults arising from circumstances that are not the responsibility of Metrohm, such as improper storage or improper use, etc. are expressly excluded from the warranty.

## 9 Accessories







### Note



Subject to change without notice!

### 9.1 Scope of delivery



#### 2.882.0030 882 Compact IC plus – Anion – MCS





Qty.	Order no.	Description	
1	1.882.0030	882 Compact IC plus – Anion – MCS	
1	6.2122.0x0	<b>Mains cable with C13 line socket IEC-60320-C13</b>	
		Cable plug according to customer requirements.	
		Switzerland:	Type SEV 12 6.2122.020
		Germany, ...:	Type CEE(7), VII 6.2122.040
		USA, ...:	Type NEMA/ASA 6.2122.070
2	6.1602.150	<b>Bottle attachment / GL 45 - 3 x UNF 10/32</b>	
		For connecting capillary tubing 1/16 in. Used with MSM auxiliary solutions and in inline dialysis	
		Material:	Plastic
			
1	6.1602.160	<b>Eluent bottle attachment GL 45</b>	
		For eluent bottles; with connections for adsorber tube and aspiration tubing.	
		Opening ground joint:	A-14/15
			

Qty.	Order no.	Description	
2	6.1608.020	<b>Glass bottle / 1000 mL / GL 45</b>	
		Bottle for auxiliary solutions	
		Width (mm):	96
		Height (mm):	223
		Volume (mL):	1000
			
1	6.1608.070	<b>Eluent bottle / 2 L / GL 45</b>	
		Material:	Clear glass
		Height (mm):	262
		Volume (mL):	2000
			
1	6.1609.000	<b>Adsorber tube / large and bent</b>	
		For filling with adsorber material.	
		Material:	Glass
		Height (mm):	129
		Inner diameter (mm):	32
		SGJ size:	B-14/15
			
1	6.1803.020	<b>PTFE capillary 0.97 mm i.d. / 5 m</b>	
		For all IC instruments	
		Material:	PTFE
		Outer diameter (mm):	1.57
		Inner diameter (mm):	0.97
		Length (m):	5
			

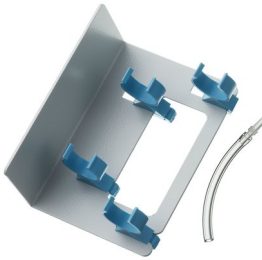
Qty.	Order no.	Description	
1	6.1803.040	<b>PTFE capillary 0.5 mm i.d. / 1 m</b> Capillary for sample handling in IC. Material: PTFE Outer diameter (inches): 1/16 Inner diameter (mm): 0.5 Length (m): 1	
1	6.1807.010	<b>Y connector for tubing i.d. 6-9 mm</b> Connector for waste tubings	
1	6.1815.010	<b>Spiral band / 0.5 m</b> For holding together different cables or tubing. Length (m): 0.5	





Qty.	Order no.	Description	
2	6.1816.020	<b>Silicone tubing 6 mm i.d. / 1 m</b> For drainage tubings Material: Silicone rubber Outer diameter (mm): 9 Inner diameter (mm): 6 Length (m): 1	
2	6.1826.320	<b>Pump tubing LFL (orange/yellow) , 3-stop- per</b> For suppressor solutions, acceptor solutions for inline dialysis and for inline ultrafiltration.	
1	6.2023.020	<b>Clip for SGJ 14/15</b> Clip for SGJ 14/15 Material: POM	
1	6.2057.080	<b>Adsorption cartridge holder</b> Holder to install adsorption cartridges in Professional IC Instruments	

Qty.	Order no.	Description	
1	6.2151.020	<b>Cable USB A - USB B / 1.8 m</b> USB connecting cable Length (m): 1.8	
1	6.2251.000	<b>Colored sleeves for capillaries</b> Colored pieces of heat shrink tubing for capillary coding. Three pieces each of five different colors.	
1	6.2322.010	<b>PRIMUS multi anion standard solution: Promo</b>	
1	6.2617.010	<b>Tool for piston seal</b> For removing and assembling the piston seal for all standard pump heads	
2	6.2621.000	<b>Adjustable wrench</b> Maximum opening: 20 mm. For IC instruments Length (mm): 150	







Qty.	Order no.	Description	
1	6.2621.030	Hexagon key 4 mm	
	Length (mm):	73	
1	6.2621.050	1/4 in. wrench	
	For 1/4 in. screws. For IC instruments		
	Length (mm):	73	
1	6.2621.080	Capillary cutter	
	For plastic capillaries. For IC instruments		
	Length (mm):	118	



Qty.	Order no.	Description
1	6.2621.100	<b>Hexagon key 3 mm</b> Hexagon key 3 mm. For IC Sample Processors Length (mm): 73
		
1	6.2626.000	<b>Front drain nozzle</b> Drain nozzle for Professional IC instruments to be mounted on the front of the instrument
		
2	6.2739.000	<b>Wrench</b> For tightening connectors Length (mm): 68
		
1	6.2743.080	<b>Stoppers for overflow, 5 pieces</b> For Professional IC instruments
		



Qty.	Order no.	Description
1	6.2744.014	<b>Pressure screw 2x</b> With UNF 10/32 connection. For the connection of PEEK capillaries Material: PEEK Length (mm): 26
		
1	6.2744.020	<b>Luer/UNF coupling</b> For IC instruments Material: PEEK Length (mm): 19
		
1	6.2744.034	<b>Coupling olive/UNF 10/32 2x</b> Connection of pressure screw and pump tubing. 2 pieces. For IC instruments with peristaltic pumps
		
1	6.2744.040	<b>2 x UNF 10/32 coupling</b> For connecting 1/16 in. capillaries. For IC instruments Material: PEEK Length (mm): 24
		

Qty.	Order no.	Description	
2	6.2744.070	<b>Pressure screw short</b>	
		<p>Short version. With UNF 10/32 connection. 5 pieces. For the connection of PEEK capillaries</p> <p>Material: PEEK</p> <p>Length (mm): 21</p>	
1	6.2744.090	<b>Pressure screw long</b>	
		<p>Long version. With UNF 10/32 connection. 2 pieces. For the connection of PEEK capillaries. (MCS and sample degasser)</p> <p>Material: PEEK</p>	
2	6.2744.180	<b>Pump tubing connection with safety device and filter</b>	
		<p>For the connection of a pump tubing and a capillary with built-in filter</p> <p>Material: PEEK</p>	
1	6.2744.210	<b>Tubing adapter for aspiration filter</b>	
		<p>For Professional IC instruments</p>	

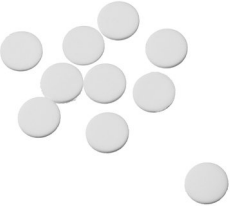

Qty.	Order no.	Description	
1	6.2816.020	<b>Syringe 10 mL with Luer connection</b>	
		For different usage in IC and VA	
		Material:	PP
		Length (mm):	102
		Volume (mL):	10
1	6.2816.040	<b>Purging needle</b>	
		With PTFE tubing and Luer connection. For syringes. For aspirating eluents.	
1	6.2821.090	<b>Aspiration filter</b>	
		Pore size 20 µm. Set of 5 pieces. For 6.1834.000 aspiration tubing and 6.1821.040 and 6.1821.050 filter tubes.	
		Material:	PE
		Outer diameter (mm):	9.5
		Length (mm):	35.5
1	6.2821.130	<b>Spare filter for inline filter</b>	
		Spare filter for inline filter.	

Qty.	Order no.	Description
------	-----------	-------------

- |   |            |   |
|---|------------|---|
| 1 | 6.2837.000 | <b>CO<sub>2</sub> adsorption cartridge</b><br>Adsorption cartridge for removing the CO <sub>2</sub> from the aspirated air. |
|---|------------|---|



- |   |            |  |
|---|------------|--|
| 2 | 6.2837.010 | <b>H<sub>2</sub>O adsorption cartridge</b><br>To CO <sub>2</sub> Suppressor. Water adsorption cartridge for the aspirated air. |
|---|------------|--|



## 9.2 Optional accessories

### 2.882.0030 882 Compact IC plus – Anion – MCS



Order no.	Description
-----------	-------------

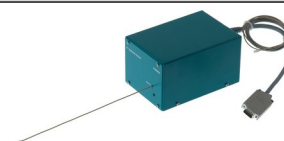

- |            |   |
|------------|---|
| 2.850.9010 | <b>850 Professional IC Detector – iDetector</b> |
|------------|---|

Compact and intelligent High Performance Conductivity Detector for intelligent IC Instruments. Outstanding temperature stability, the complete signal processing within the protected detector block and the latest generation of «DSP» – Digital Signal Processing – guarantee the highest precision for the measurement. No change of measuring ranges – not even automatic – is required due to the dynamic working range.





Order no.	Description	
<b>6.2617.040</b>	<b>Tool for piston seal Macro</b>	
For removing and assembling the piston seal for Macro pump heads		
<b>6.2741.040</b>	<b>PE/PTFE piston seal Macro</b>	
For all Macro pump heads		
<b>6.2824.130</b>	<b>Macro pump head PEEK</b>	
Macro pump head for intelligent IC instruments, flow range 0.1...20 mL/min, maximum pressure 12.5 MPa.		
Material:	PEEK (metal-free)	
<b>6.5333.000</b>	<b>IQ/OQ Kit for IC</b>	
The IQ/OQ Kit contains all parts and standard solutions required for IQ/OQ in ion chromatography.		
<b>6.6059.221</b>	<b>MagIC Net™ 2.2 Compact CD: 1 license</b>	
Professional PC program for controlling an intelligent Compact IC systems and an Autosampler or a 771 Compact Interface. The software permits control, data acquisition, evaluation and monitoring as well as report generation of ion chromatographic analyses. Graphics user interface for routine operations, extensive database programs, method development, configuration and manual system control; very flexible user administration, efficient database operations, extensive data export functions, individually configurable report generator, control and monitoring of all system components and the chromatography results. MagIC Net™ Compact complies fully with FDA Regulation 21 CFR Part 11 as		

Order no.	Description	
	well as GLP. Dialog languages: German, English, French, Spanish, Chinese, Korean, Japanese, et. al. 1 license.	
<b>6.6059.222</b>	<b>MagIC Net™ 2.2 Professional CD : 1 license</b>	
	Professional PC program for controlling intelligent Professional IC systems, Compact IC systems and their peripherals such as various Autosamplers, 800 Dosino, 771 Compact Interface, etc. The software permits control, data acquisition, evaluation and monitoring as well as report generation of ion chromatographic analyses. Graphics user interface for routine operations, extensive database programs, method development, configuration and manual system control; very flexible user administration, efficient database operations, extensive data export functions, individually configurable report generator, control and monitoring of all system components and the chromatography results. MagIC Net™ Professional complies fully with FDA Regulation 21 CFR Part 11 as well as GLP. Dialog languages: German, English, French, Spanish, Chinese, Korean, Japanese, et. al. 1 license.	
<b>6.6059.223</b>	<b>MagIC Net™ 2.2 Multi CD: 3 licenses</b>	
	Professional PC program for controlling intelligent Professional IC systems, Compact IC systems and their peripherals such as various Autosamplers, 800 Dosino, 771 Compact Interface, etc. The software permits control, data acquisition, evaluation and monitoring as well as report generation of ion chromatographic analyses. Graphics user interface for routine operations, extensive database programs, method development, configuration and manual system control; very flexible user administration, efficient database operations, extensive data export functions, individually configurable report generator, control and monitoring of all system components and the chromatography results. MagIC Net™ Multi complies fully with FDA Regulation 21 CFR Part 11 as well as GLP. Dialog languages: German, English, French, Spanish, Chinese, Korean, Japanese, et. al. Client Server version with 3 licenses.	
<b>6.9988.823</b>	<b>Validation Documentation for 882 (English / German) – CD</b>	



# Index

## Numbers/Symbols

6.2821.090 aspiration filter ..... 63  
 (6.2821.130) Filter ..... 74

## A

Accessories ..... 105  
     Optional ..... 115  
     Scope of delivery ..... 105  
 Adsorber cartridges  
     Connection ..... 50  
 Ambient conditions ..... 95  
 Aspiration filter 6.2821.090 ..... 63  
 Aspiration tubing for eluent ..... 25

## B

Baseline  
     Conditioning ..... 59  
     Unstable ..... 64  
 Blood ..... 76

## C

Cable feed-throughs ..... 23  
 Capillaries  
     Installation ..... 17  
 Capillary feed-throughs ..... 23  
 Carry-over ..... 76  
 Cartridges  
     Connection ..... 50  
 Changing  
     Eluent ..... 63  
 Cleaning  
     Suppressor ..... 84  
     Valves of the high pressure  
     pump ..... 69  
 CO<sub>2</sub> adsorption cartridge ..... 50  
     Replacement ..... 87  
 Column  
     see also "Separation column"  
     ..... 54  
 Column recognition ..... 98  
 Conditioning ..... 59  
 Connections  
     Installation ..... 17  
 Connector  
     Mains ..... 98  
 Contamination  
     High pressure pump ..... 63  
     Valves in the high pressure  
     pump ..... 64

Contamination suppressor  
     Heavy metals ..... 82  
     Organic impurities ..... 82  
 Crystallization  
     High pressure pump ..... 63

## D

Deaerating  
     High pressure pump ..... 32  
     Purge valve ..... 29  
 Design  
     Safety specification ..... 99  
 Detector  
     Interface ..... 98  
 Dilution ..... 76  
 Dimensions ..... 96  
 Door ..... 62  
 Drainage tubings  
     Installation ..... 21

## E

Electromagnetic compatibility ... 99  
 Electrostatic charge ..... 5  
 Eluent  
     Aspiration ..... 25  
     Production ..... 62  
 Eluent bottle  
     Figure ..... 28  
     Installation ..... 25  
     Operation ..... 63  
 EMC ..... 99  
 Emission ..... 99  
 Equilibration ..... 57, 59

## F

Feed-throughs  
     Capillaries ..... 23  
 Fill  
     Injection valve ..... 38  
 Filter  
     see also "inline filter" ..... 34  
 Filter (6.2821.130) ..... 74  
 Filter 6.2821.090  
     Aspiration filter ..... 63  
 Flow fluctuations ..... 64  
 Flow increment ..... 96  
 Flow range ..... 96  
 Flow rate ..... 96  
 Frequency ..... 98

## G

GLP ..... 89  
 Guarantee ..... 103  
 Guard column  
     Installation ..... 53  
     Rinsing ..... 54

## H

H<sub>2</sub>O adsorption cartridge ..... 51  
     Regeneration ..... 87  
 Heavy metals  
     Contamination suppressor .. 82  
 High pressure pump  
     Installation ..... 29  
     Maintenance ..... 63  
     Protection ..... 20, 63  
     Technical specifications ..... 96  
     Tubing connection ..... 29  
     Valves ..... 72  
 Housing ..... 96  
 Humidity ..... 95

## I

IC column  
     see also "Separation column"  
     ..... 54  
 Immunity ..... 99  
 Inject  
     Injection valve ..... 39  
 Injection valve ..... 2  
     Fill ..... 38  
     Inject ..... 39  
     Installation ..... 36, 97  
     Maintenance ..... 76  
     Protection ..... 76  
 Inline filter ..... 34  
 Inline sample preparation ..... 76  
 Installation  
     Connections ..... 17  
     Drainage tubings ..... 21  
     Eluent bottle ..... 25  
     Guard column ..... 53  
     High pressure pump ..... 29  
     Injection valve ..... 36, 97  
     Leak sensor ..... 20  
     MCS ..... 48  
     MSM ..... 45  
     Peristaltic pump ..... 41  
     Pulsation absorber ..... 35  
     Pump tubings ..... 41

- Separation column ..... 54  
 Suppressor ..... 45  
 Instrument  
   Connecting ..... 52  
 Interface  
   MSB ..... 98  
   USB ..... 98  
 Interfaces ..... 98  
   Further connections ..... 99  
   Leak sensor ..... 99
- L**
- Leak ..... 64  
 Leaking piston seals ..... 64  
 Leak sensor  
   Installation ..... 20  
   Interface ..... 99  
   Technical data ..... 95  
 Leak-tightness ..... 58, 59  
 Loop  
   see also "Sample loop" ..... 39
- M**
- Mains cable ..... 52  
 Mains connection ..... 52, 98  
 Mains voltage ..... 5  
 Maintenance  
   High pressure pump ..... 63  
   Injection valve ..... 76  
   Peristaltic pump ..... 78  
   Pump head ..... 64  
 Material ..... 96  
 MCS  
   Capillary connector ..... 48  
   Connecting the cartridges ... 50  
   Installation ..... 48  
   Technical specifications ..... 98  
   Use ..... 48  
 MSB ..... 98  
 MSM  
   see also "Suppressor" ..... 45  
   Technical specifications ..... 97
- O**
- Oil ..... 76  
 Operation  
   Peristaltic pump ..... 78  
   Suppressor ..... 81  
 Organic impurities  
   Contamination suppressor .. 82  
 Overview of the instrument  
   Front ..... 7  
   Rear ..... 8
- P**
- PC connector ..... 52  
 Peristaltic pump  
   Installation ..... 41  
   Maintenance ..... 78  
   Operation ..... 78  
   Principle ..... 39  
   Technical specifications ..... 97  
 Piston seal ..... 64  
 Pistons of the high pressure pump  
   ..... 64  
 Power consumption ..... 98  
 Power supply unit ..... 98  
 Precipitates ..... 63  
 Pressure limit ..... 96  
 Pressure range ..... 96  
 Pressure screws  
   Connection ..... 18  
 Protection  
   Injection valve ..... 76  
   Inline filter ..... 34  
   Suppressor ..... 80  
   Protection class ..... 99  
 Pulsation ..... 64  
 Pulsation absorber  
   Installation ..... 35  
 Pump head  
   Maintenance ..... 64  
 Pump tubing  
   Overview ..... 79  
 Pump tubings  
   Installing ..... 41  
   Service life ..... 78  
 Purge valve ..... 29
- Q**
- Quality Management ..... 89
- R**
- Reference conditions ..... 95  
 Regeneration ..... 60  
   Suppressor ..... 82  
 Rinsing  
   Guard column ..... 54  
   Pump tubings ..... 78  
   Sample path ..... 76  
   Separation column ..... 56  
 Rinsing time ..... 77  
 Rise in pressure ..... 63
- S**
- Safety instructions ..... 4  
 Safety shutdown ..... 96  
 Safety specification ..... 99
- Sample  
   Carry-over ..... 76  
   Sample loop ..... 39  
   Transfer time ..... 76  
 Sample loop ..... 39  
 Sample path  
   Rinsing ..... 76  
 Sample preparation ..... 76  
 Scope of delivery ..... 105  
 Screws  
   Connection ..... 18  
 Separation column  
   Installation ..... 54  
   Protection ..... 2, 36, 88  
   Regeneration ..... 89  
   Rinsing ..... 56  
   Separating efficiency ..... 88  
   Storage ..... 89  
 Service ..... 5, 60  
 Service Agreement ..... 89  
 Shutting down ..... 61  
 Standards ..... 99  
 Start-up ..... 57  
 Storage ..... 95  
 Suppressor  
   Cleaning ..... 84  
   Installation ..... 45  
   Operation ..... 81  
   Protection ..... 80  
   Regeneration ..... 82  
   Replacing parts ..... 85  
   Switching ..... 81  
 Switch on ..... 52
- T**
- Technical data  
   Leak sensor ..... 95  
   Reference conditions ..... 95  
 Technical specifications  
   Detector ..... 98  
   High pressure pump ..... 96  
   Instrument ..... 95  
   Interfaces ..... 98  
   MCS ..... 98  
   MSM ..... 97  
   Peristaltic pump ..... 97  
 Temperature ..... 95  
 Test  
   Safety specification ..... 99  
 Transfer time ..... 76  
 Transport ..... 95  
 Transport locking screws ..... 20  
 Tubing pump  
   See also "Peristaltic pump" . 39

**Index**



Tubings  
Installation ..... 17

**U**

USB ..... 98

**V**

Vacuum pump  
Protection ..... 20

Validation ..... 89  
Valve  
    see also "Injection valve" .... 36  
Valves of the high pressure pump  
..... 72  
Voltage ..... 98

**W**

Warranty ..... 103