

856 Conductivity Module



Manual

8.856.8005EN / v9 / 2025-09-12



Metrohm AG
CH-9100 Herisau
Switzerland
Phone +41 71 353 85 85
Fax +41 71 353 89 01
info@metrohm.com
www.metrohm.com

856 Conductivity Module

Manual

Technical Communication
Metrohm AG
CH-9100 Herisau
techcom@metrohm.com

This documentation is protected by copyright. All rights reserved.

This documentation has been prepared with great care. However, errors can never be entirely ruled out. Please send comments regarding possible errors to the address above.

Table of contents

1	Introduction	1
1.1	Conductivity Module system	1
1.2	Instrument description	2
1.3	Measuring modes and commands	2
1.4	Accessories	3
1.5	Symbols and conventions	3
2	Safety	5
2.1	Intended use	5
2.2	Responsibility of the operator	5
2.3	Personnel requirement	6
2.4	Safety instructions	6
2.4.1	Electrical safety	6
2.4.2	Tubing and capillary connections	7
2.4.3	Flammable solvents and chemicals	7
3	Overview of the instrument	8
4	Installation	10
4.1	Setting up the instrument	10
4.1.1	Packaging	10
4.1.2	Checks	10
4.1.3	Location	10
4.2	Connecting a controller	10
4.2.1	Operation	10
4.3	Connecting MSB devices	15
4.3.1	Connecting a dosing device	16
4.3.2	Connecting a stirrer or titration stand	17
4.3.3	Connecting a Remote Box	18
4.4	Connecting USB devices	19
4.4.1	General	19
4.4.2	Connecting a USB hub	20
4.4.3	Connecting a printer	20
4.4.4	Connecting a balance	21
4.4.5	Connecting a PC keyboard (only for operation with Touch Control)	22
4.4.6	Connecting a barcode reader	23
4.5	Connecting sensors	24
4.5.1	Connecting a conductivity measuring cell	24



5	Operation and maintenance	26
5.1	Care	26
5.2	Maintenance by Metrohm Service	26
6	Troubleshooting	27
6.1	General	27
7	Appendix	28
7.1	Remote interface	28
7.1.1	Pin assignment of the remote interface	28
8	Technical specifications	32
8.1	Measuring interface	32
8.1.1	Conductivity	32
8.1.2	Temperature	32
8.2	Power connection	33
8.3	Ambient conditions	33
8.4	Reference conditions	33
8.5	Dimensions	34
8.6	Interfaces	34
	Index	35

Table of figures

Figure 1	856 Conductivity Module system	1
Figure 2	Front 856 Conductivity Module	8
Figure 3	Rear 856 Conductivity Module	9
Figure 4	Connecting the Touch Control	11
Figure 5	Connecting the computer	14
Figure 6	MSB connections	15
Figure 7	Connecting a dosing device	17
Figure 8	Connecting an MSB stirrer	18
Figure 9	Connecting the rod stirrer to the titration stand	18
Figure 10	Connecting the Remote Box	19
Figure 11	Connecting a printer	21
Figure 12	Connecting a conductivity measuring cell	24
Figure 13	Connecting the adapter box	25
Figure 14	Connecting the conductivity measuring cell to the adapter box	25
Figure 15	Connectors of the Remote Box	28
Figure 16	Pin assignment of remote socket and remote plug	28

1 Introduction

1.1 Conductivity Module system

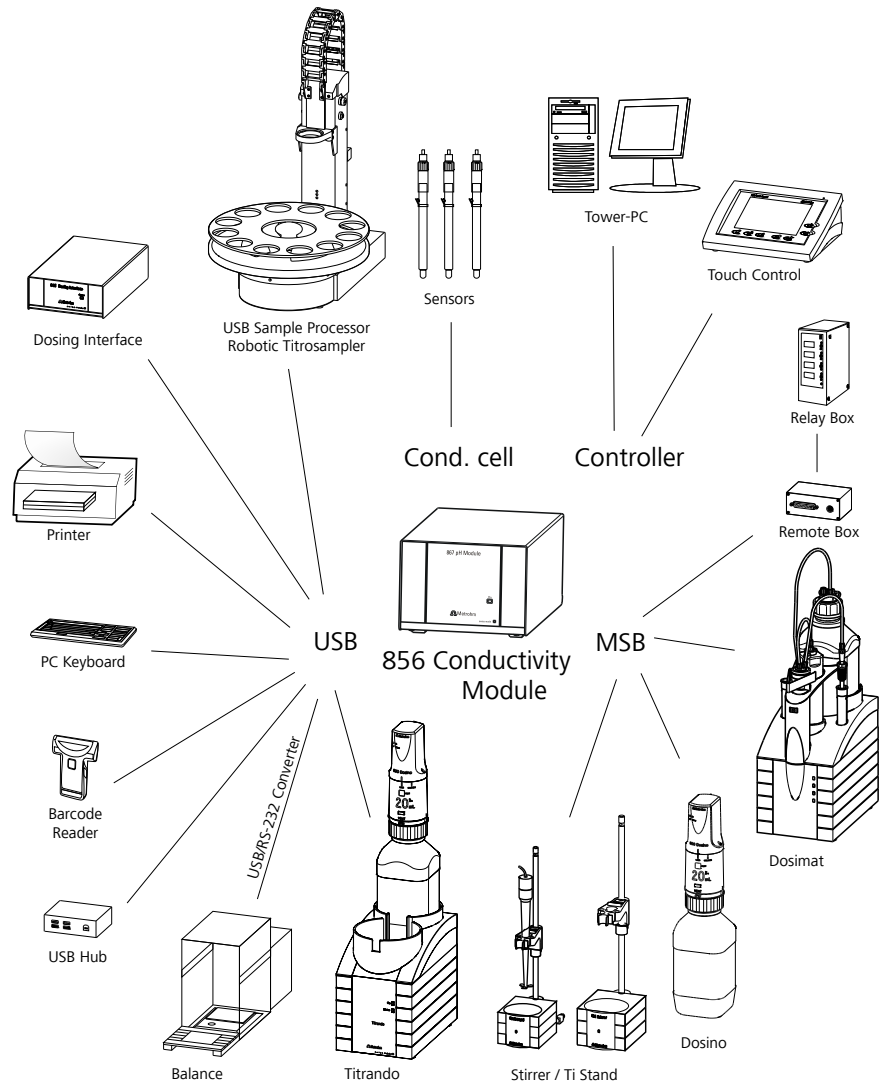

Figure 1 856 Conductivity Module system

1.4 Accessories

Up-to-date information on the scope of delivery and optional accessories for your product can be found on the Internet. You can download this information using the article number as follows:

Downloading the accessories list

- 1 Enter <https://www.metrohm.com/> into your Internet browser.
- 2 Enter the article number (e.g. **856**) into the search field.
The search result is displayed.
- 3 Click on the product.
Detailed information regarding the product is shown on various tabs.
- 4 On the **Included parts** tab, click on **Download the PDF**.
The PDF file with the accessories data is created.



NOTE

Once you have received your new product, we recommend downloading the accessories list from the Internet, printing it out and keeping it together with the manual for reference purposes.

1.5 Symbols and conventions

The following symbols and formatting may appear in this documentation:

(5- 12)	Cross-reference to figure legend The first number refers to the figure number, the second to the device part in the figure.
1	Instruction step Perform the steps one after the other.
Method	Dialog text, parameter in the software
File ► New	Menu or menu item
[Continue]	Button or key

**WARNING**

This symbol draws attention to a possible life-threatening hazard or risk of injury.

**WARNING**

This symbol draws attention to a possible hazard due to electrical current.

**WARNING**

This symbol draws attention to a possible hazard due to heat or hot instrument parts.

**WARNING**

This symbol draws attention to a possible biological hazard.

**WARNING**

Warning of optical radiation

**CAUTION**

This symbol draws attention to possible damage to devices or device parts.

**NOTICE**

This symbol highlights additional information and tips.

2 Safety



WARNING

Operate this instrument only according to the information contained in this documentation.

This instrument left the factory in a flawless state in terms of technical safety. To maintain this state and ensure non-hazardous operation of the instrument, the following instructions must be observed carefully.

2.1 Intended use

2.2 Responsibility of the operator

The operator is responsible for the following tasks to ensure the safe operation of the product:

- Check the condition of the product before use:
- Ensure that the operating values and limit values specified in the technical specifications () are observed.
- Maintain and clean the product regularly:
- Remedy defects and malfunctions immediately:



NOTE

The product may be used only when its status is perfect.

- Train staff on basic occupational safety and accident prevention regulations for chemical laboratories and ensure that these regulations are complied with.
- Train personnel in the use of the product according to the user documentation (e.g., install, operate, eliminate faults).
- Provide personal protective equipment (e.g., protective glasses, gloves).
- Provide suitable tools and equipment to execute the work safely.

Supply voltage



WARNING

An incorrect supply voltage can damage the instrument.

Only operate this instrument with a supply voltage specified for it (see rear panel of the instrument).

Protection against electrostatic charges



WARNING

Electronic components are sensitive to electrostatic charges and can be destroyed by discharges.

Do not fail to pull the power cord out of the power socket before you set up or disconnect electrical plug connections at the rear of the instrument.

2.4.2 Tubing and capillary connections



CAUTION

Leaks in tubing and capillary connections are a safety risk. Tighten all connections well by hand. Avoid applying excessive force to tubing connections. Damaged tubing ends lead to leakage. Appropriate tools can be used to loosen connections.

Check the connections regularly for leakage. If the instrument is used mainly in unattended operation, then weekly inspections are mandatory.

2.4.3 Flammable solvents and chemicals



WARNING

All relevant safety measures are to be observed when working with flammable solvents and chemicals.

- Set up the instrument in a well-ventilated location (e.g. fume cupboard).
- Keep all sources of flame far from the workplace.
- Clean up spilled liquids and solids immediately.
- Follow the safety instructions of the chemical manufacturer.

3 Overview of the instrument

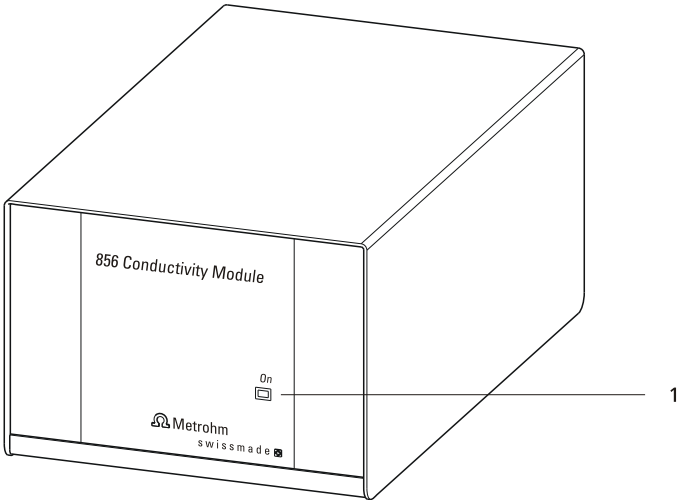

Figure 2 Front 856 Conductivity Module

- 1 "On" LED**
Lights up when the Conductivity Module is ready for operation.

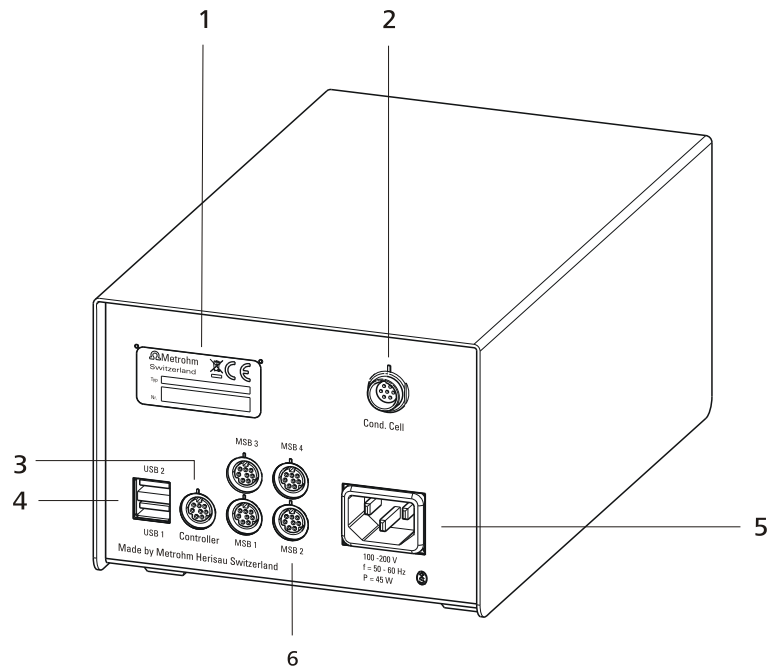

Figure 3 Rear 856 Conductivity Module

1 Type plate

Contains specifications concerning supply voltage, instrument type and serial number.

2 Conductivity measuring cell connector (Cond. Cell)

For connecting a 5-ring conductivity measuring cell with integrated temperature sensor. Other Metrohm conductivity measuring cells can be connected through the 6.2103.160 adapter box.

3 Connector (Controller)

For connecting a Touch Control or a PC with installed PC software. Mini DIN, 9-pin.

4 USB connector (USB 1 and USB 2)

USB ports (type A) for connecting printer, keyboard, barcode reader, additional Titrandos, USB Sample Processor, etc.

5 Power socket

6 MSB connector (MSB 1 to MSB 4)

Metrohm Serial Bus. For connecting external dosing devices, stirrers or Remote Boxes. Mini DIN, 9-pin.

4.2.1.1 Connecting a Touch Control



NOTE

The plug is protected against accidental disconnection of the cable by means of a pull-out protection feature. If you wish to pull out the plug, you first need to pull back the outer plug sleeve marked with arrows.

Connect the Touch Control as follows:

- 1 ■ Insert the plug of the Touch Control connection cable into the **Controller** socket.

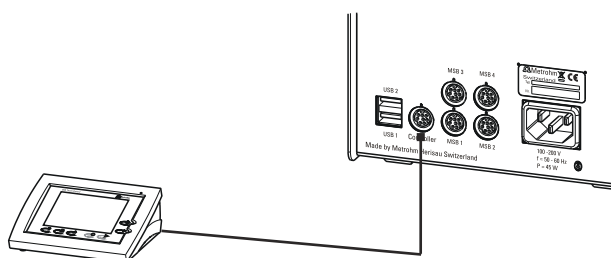

Figure 4 Connecting the Touch Control

- 2 ■ Connect the MSB devices (*see chapter 4.3, page 15*).
 - Connect the USB devices (*see chapter 4.4, page 19*).
- 3 ■ Connect the Conductivity Module to the power grid (*see chapter 4.2.1, page 10*).
- 4 ■ Switch on the Touch Control.

The Touch Control power supply is supplied through the Conductivity Module. Automatic system tests are performed on both instruments at the time of activation. The **On** LED on the front of the Conductivity Module lights up when the system test has been completed and the instrument is ready for operation.



CAUTION

The Touch Control must be shut down properly by deactivation with the power switch on the rear of the instrument before the power supply is interrupted. If this is not done, then there is a danger of data loss. Because of the fact that the power supply for the Touch Control is provided through the Conductivity Module, you must never disconnect the Conductivity Module from the power grid (e.g. by deactivating with a connector strip) before you have deactivated the Touch Control.

If you would prefer not to position the Touch Control directly next to the Conductivity Module, then you can lengthen the connection with the 6.2151.010 cable. The maximum connection length permitted is 5 m.

4.2.1.2 Connecting the instrument to the power grid



WARNING

Electric shock from electrical potential

Risk of injury by touching live components or through moisture on live parts.

- Never open the housing of the instrument while the power cord is still connected.
- Protect live parts (e.g. power supply unit, power cord, connection sockets) against moisture.
- Unplug the power plug immediately if you suspect that moisture has gotten inside the instrument.
- Only personnel who have been issued Metrohm qualifications may perform service and repair work on electrical and electronic parts.

Connecting the power cord

Accessories

Power cord with the following specifications:

- Length: max. 2 m
- Number of cores: 3, with protective conductor
- Instrument plug: IEC 60320 type C13
- Conductor cross-section 3x min. 0.75 mm² / 18 AWG
- Power plug:
 - according to customer requirement (6.2122.XX0)
 - min. 10 A

**NOTE**

Do not use a not permitted power cord!

1 Plugging in the power cord

- Plug the power cord into the instrument's power socket.
- Connect the power cord to the power grid.

4.2.1.3 Connecting a computer

The 856 Conductivity Module requires a USB connection to a computer in order to be able to be controlled by a computer software. Using a 6.2151.000 controller cable, the instrument can be connected directly, either to a USB socket on a computer, to a connected USB hub or to a different Metrohm control instrument.

You need administrator rights for the installation of driver software and control software on your computer.

Cable connection and driver installation

A driver installation is required in order to ensure that the 856 Conductivity Module is recognized by the computer software. To accomplish this, you must comply with the procedures specified. The following steps are necessary:

1 Install the software

- Insert the computer software installation CD and carry out the installation program directions.
- Exit the program if you have started it after the installation.

2 Establishing the cable connections

- Connect all peripheral devices to the instrument, *see chapter 4.3, page 15*.
- Connect the instrument to the power grid if you have not already done this (*see chapter 4.2.1.2, page 12*).
The "On" LED on the 856 Conductivity Module is not yet illuminated!
- Connect the instrument to a USB connector (type A) of your computer (see manual of your computer). The 6.2151.000 cable is used for this purpose.

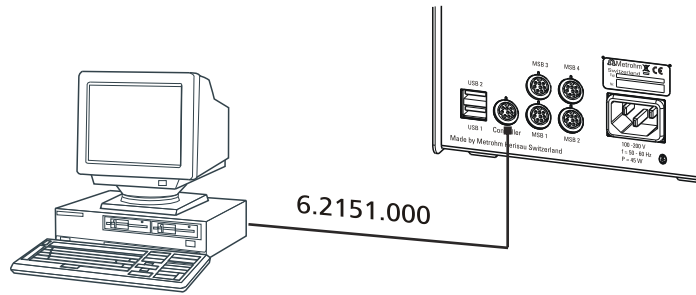

Figure 5 Connecting the computer

The instrument is recognized. Depending on the version of the Windows operating system used, the driver installation proceeds differently afterwards. Either the necessary driver software is installed automatically or an installation wizard is started.

3 Follow the instructions of the installation wizard.

The "On" LED on the 856 Conductivity Module lights up when the driver installation has been completed and the instrument is ready for operation.

If problems should occur during installation, contact your company's IT support team.



NOTE

The plug on the instrument end of the 6.2151.000 controller cable is protected against accidental disconnection by means of a pull-out protection feature. If you wish to pull out the plug, you first need to pull back the outer plug sleeve marked with arrows.

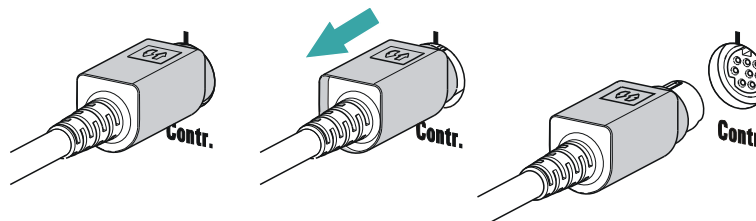

Registering and configuring the instrument in the computer software

The instrument must be registered in the configuration of your computer software. Once that has been done, you can then configure it according to your requirements. Proceed as follows:

1 Setting up the instrument

- Start the computer software.
The instrument is automatically recognized. The configuration dialog for the instrument is displayed.
- Make configuration settings for the instrument and its connectors.

More detailed information concerning the configuration of the instrument can be found in the documentation for the respective computer software.

4.3 Connecting MSB devices

In order to connect MSB devices, e.g. stirrers or dosing devices, Metrohm instruments are equipped with up to a maximum of four connectors on what is referred to as the *Metrohm Serial Bus* (MSB). Various kinds of peripheral devices can be connected in sequence (in series, as a "Daisy Chain") at a single MSB connector (8-pin Mini DIN socket) and controlled simultaneously by the respective control instrument. In addition to the connection cable, stirrers and the Remote Box are each equipped with their own MSB socket for this purpose.

The following figure provides an overview of the instruments that can be connected to an MSB socket, along with a number of different cabling variations.

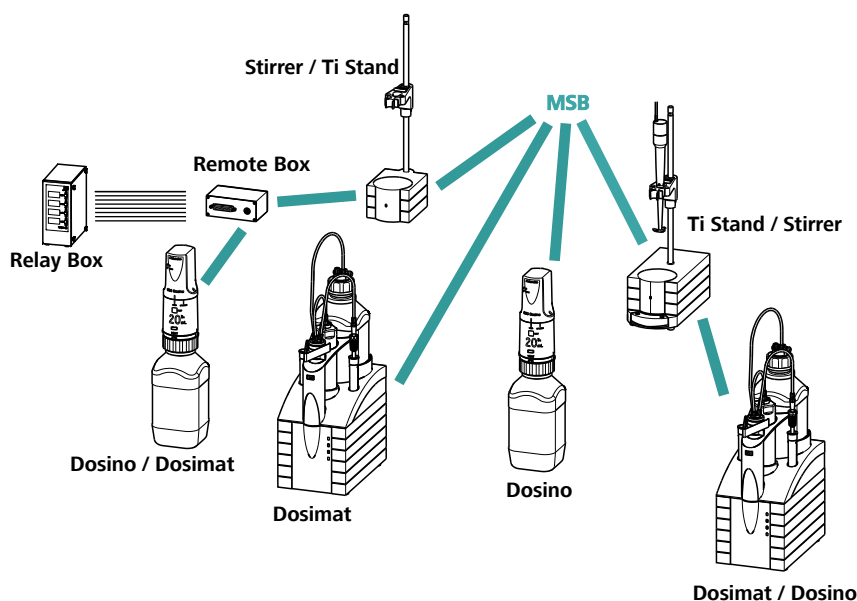

Figure 6 MSB connections

The control instrument determines which peripheral devices are supported.

**NOTE**

When connecting MSB devices together, the following must be observed:

- Only one device of the same type can be used at a single MSB connector at one time.
- Dosing devices of the 700 Dosino and 685 Dosimat plus type cannot be connected together with other MSB devices on a shared connector. These dosing devices must be connected separately.

**CAUTION**

Exit the control software before you plug in MSB devices. When it is switched on, the control instrument automatically recognizes which device is connected to which MSB connector. The operating unit or the control software enters the connected MSB devices into the system configuration (device manager).

MSB connections can be extended with the 6.2151.010 cable. The maximum connection length permitted is 15 m.

4.3.1 Connecting a dosing device

Four dosing devices can be connected to the instrument (**MSB 1 to MSB 4**).

The types of dosing devices that are supported are:

- 800 Dosino
- 700 Dosino
- 805 Dosimat
- 685 Dosimat plus

Proceed as follows:

1 Connecting a dosing device

- Exit the control software.
- Connect the connection cable of the dosing device to one of the sockets marked with **MSB** on the rear of the control device.
- Start the control software.

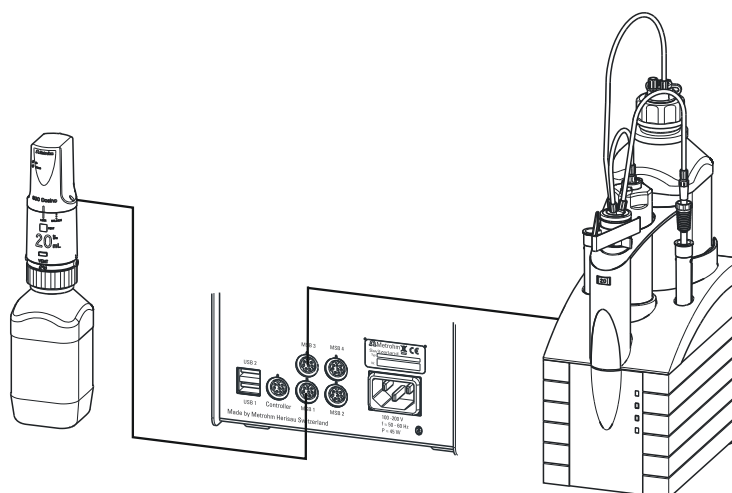

Figure 7 Connecting a dosing device

4.3.2 Connecting a stirrer or titration stand

You can use the following instruments:

These devices have a built-in magnetic stirrer (stirring "from below"):

- 801 Stirrer
- 803 Ti Stand

This device has no built-in magnetic stirrer (stirring "from above"):

- 804 Ti Stand with rod stirrer 802 Stirrer

Connect a stirrer or a titration stand as follows:

1 Connecting the stirrer or titration stand

- Exit the control software.
- Connect the connection cable of the magnetic stirrer or of the titration stand to one of the sockets marked with **MSB** on the rear of the control instrument.
- 804 Ti Stand only: Connect the rod stirrer to the stirrer connector (socket with stirrer symbol) of the titration stand.
- Start the control software.

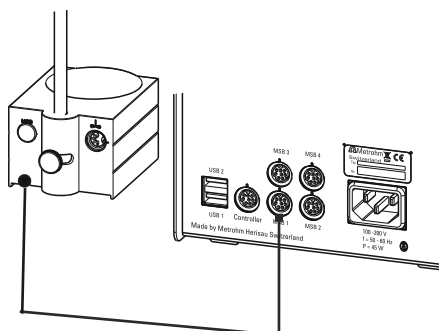

Figure 8 Connecting an MSB stirrer

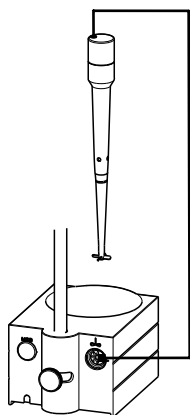

Figure 9 Connecting the rod stirrer to the titration stand

4.3.3 Connecting a Remote Box

Instruments that are controlled via remote lines and/or that send control signals via remote lines can be connected via the 6.2148.010 Remote Box. In addition to Metrohm, other instrument manufacturers also use similar connectors that make it possible to connect different instruments together. These interfaces are also frequently given the designations "TTL Logic", "I/O Control" or "Relay Control" and they generally have a signal level of 5 volts.

Control signals are understood to be electrical line statuses or electrical pulses (> 200 ms) which display the operating status of an instrument or which trigger or report an event. Sequences on a variety of instruments can thus be coordinated in a single complex automation system. However, no exchange of data is possible.

Proceed as follows:

1 Connecting the Remote Box

- Exit the control software.
- Connect the Remote Box connection cable to one of the sockets marked with **MSB** on the rear of the control instrument.
- Start the control software.

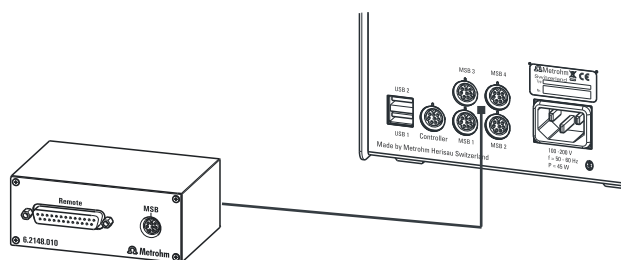

Figure 10 Connecting the Remote Box

You can connect the following instruments to the remote connector, among others:

- 849 Level Control (fill level monitoring in a canister)
- 731 Relay Box (switch box for 230/110 volt alternating current sockets and low-voltage direct current outlets)
- 843 Pump Station (for complex sample preparations or for rinsing external titration vessels)

The Remote Box also has an MSB socket at which a further MSB device, e.g. a dosing device or a stirrer, can be connected.

You will find precise information concerning the pin assignment of the interface on the Remote Box in the *appendix*.

4.4 Connecting USB devices

4.4.1 General

The 856 Conductivity Module has two USB connectors (type A sockets) for peripheral devices with USB interfaces. The 856 Conductivity Module functions as a USB hub (distributor) no matter how it is operated. If you wish to connect more than two devices to the USB, you can also use an additional, commercially available USB hub.



CAUTION

If you operate the 856 Conductivity Module with the aid of the Touch Control, take care to ensure that the Touch Control is switched off when you set up or disconnect connections between the various instruments. If you use a PC software to control the 856 Conductivity Module, you should exit the program before you set up or disconnect the USB connections.



4.4.2 Connecting a USB hub

If you wish to connect more than two devices to the USB connector of the 856 Conductivity Module, you can also use an additional commercially available USB hub (distributor). If you operate the 856 Conductivity Module with the help of the Touch Control, then you should use a USB hub with its own power supply.

Connect the USB hub as follows:

- 1 Switch off the Touch Control and/or exit the PC software.
- 2 With the aid of the 6.2151.020 cable, connect the USB connector of the 856 Conductivity Module (type A) with the USB connector of the hub (type B, see manual for the hub).

- 3 Switch on the Touch Control.

The USB hub is recognized automatically.

4.4.3 Connecting a printer

Printers that are connected to the 856 Conductivity Module with Touch Control must meet the following requirements:

- Printer languages: HP-PCL (PCL 3 to 5, PCL 3GUI), Canon BJI Commands or Epson ESC P/2
- Printer resolution: 300 dots/inch or 360 dots/inch (Epson)
- Paper size: A4 or Letter, single-sheet feed.

Connect the printer as follows:

- 1 Switch off the Touch Control.
- 2 With the aid of the 6.2151.020 cable, connect the USB connector of the 856 Conductivity Module (type A) with the USB connector of the printer (type B, see manual for the printer).
- 3 Switch on the printer first, then the Touch Control.
- 4 Configure the printer in the device manager of the Touch Control (see Touch Control manual).

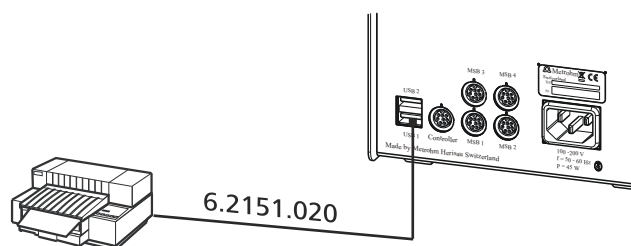

Figure 11 Connecting a printer

4.4.4 Connecting a balance

- Operation with a PC software:
 - Connect the balance directly to the serial connector (COM) of the computer. This is usually 9-pin and marked with the symbol **IOIOI**.
- Operation with Touch Control:
 - You will need the 6.2148.050 USB/RS-232 adapter to connect a balance.

The following table offers an overview of the balances that you can use together with the 856 Conductivity Module and of which cable you will need for connection to the RS-232 interface:

Balance	Cable
AND ER, FR, FX with RS-232 interface (OP-03)	6.2125.020 + 6.2125.010
Mettler AB, AG, PR (LC-RS9)	In the scope of delivery for the balance
Mettler AM, PM, PE with interface option 016 or Mettler AJ, PJ with interface option 018	6.2146.020 + 6.2125.010 Also from Mettler: ME 47473 adapter and either ME 42500 hand switch or ME 46278 foot switch
Mettler AT	6.2146.020 + 6.2125.010 Also from Mettler: ME 42500 hand switch or ME 46278 foot switch
Mettler AX, MX, UMX, PG, AB-S, PB-S, XP, XS	6.2134.120
Mettler AE with interface option 011 or 012	6.2125.020 + 6.2125.010 Also from Mettler: ME 42500 hand switch or ME 46278 foot switch



Balance	Cable
Ohaus Voyager, Explorer, Analytical Plus	Cable AS017-09 from Ohaus
Precisa balances with RS-232-C interface	6.2125.080 + 6.2125.010
Sartorius MP8, MC, LA, Genius, Cubis	6.2134.060
Shimadzu BX, BW	6.2125.080 + 6.2125.010

Operation with Touch Control

Connect the balance as follows:

- 1 Plug in the USB plug of the USB/RS-232 adapter at the USB connector of the 856 Conductivity Module.
- 2 Connect the RS-232 interface of the USB/RS-232 adapter with the RS-232 interface of the balance (see table for cable).
- 3 Switch on the Touch Control.
- 4 Switch on the balance.
- 5 Activate the RS-232 interface of the balance if necessary.
- 6 Configure the RS-232 interface of the USB/RS-232 adapter in the device manager of the Touch Control (see Touch Control manual).

4.4.5 Connecting a PC keyboard (only for operation with Touch Control)

The PC keyboard is used as an aid for text and numerical input.

Connect the PC keyboard as follows:

- 1 Insert the USB plug of the keyboard into one of the USB sockets of the 856 Conductivity Module.
- 2 Switch on the Touch Control.

The keyboard is recognized automatically and entered in the device manager.

- 3 Configure the keyboard in the device manager of the Touch Control (see Touch Control manual).

4.4.6 Connecting a barcode reader

The barcode reader is used as an aid for text and numerical input. You can connect a barcode reader with USB interface.

Operation with Touch Control

Connect the barcode reader as follows:

- 1 Insert the USB plug of the barcode reader into one of the USB sockets of the 856 Conductivity Module.
- 2 Switch on the Touch Control.
The barcode reader is recognized automatically and entered in the device manager.
- 3 Configure the barcode reader in the device manager of the Touch Control (see Touch Control manual).

Settings on the barcode reader:

Program the barcode reader as follows (see also the manual for the barcode reader):

- 1 Switch the barcode reader to programming mode.
- 2 Specify the desired layout for the keyboard (USA, Germany, France, Spain, German-speaking Switzerland).
This setting must match the setting in the device manager (see the Touch Control manual).
- 3 Make sure that the barcode reader is set in such a way that Ctrl characters (ASCII 00 to 31) can be sent.
- 4 Program the barcode reader in such a way that the ASCII character 02 (STX or Ctrl B) is sent as the first character. This first character is normally referred to as the "Preamble" or "Prefix Code".
- 5 Program the barcode reader in such a way that the ASCII character 04 (EOT or Ctrl D) is sent as the last character. This last character is

Connecting older models

Connect older models of the conductivity measuring cell as follows:

- 1 Connect the adapter box to the **Cond. Cell** socket of the 856 Conductivity Module.

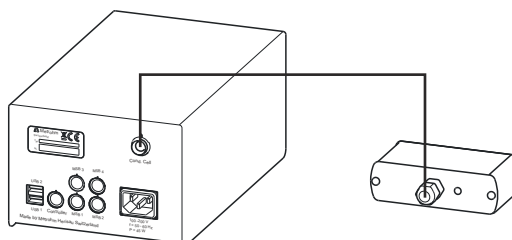

Figure 13 Connecting the adapter box

- 2 Plug the black plugs of the conductivity measuring cell into the black **Cond. Cell** sockets and the red plugs into the red **Pt 1000** sockets on the front of the adapter box.

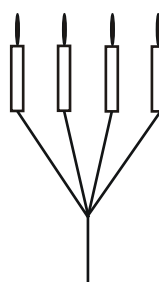
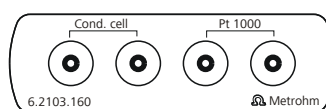

Figure 14 Connecting the conductivity measuring cell to the adapter box

During conductivity measurements, take care to ensure that

- the measuring cell is positioned in such a way that the upper side openings are completely immersed in the liquid.
- no air bubbles adhere to the Pt rings or Pt platelets. Air bubbles present inside the measuring cell can be removed by swinging back and forth and by tapping.
- the conductivity measuring cell is not so deeply submerged in the solution that it becomes damaged when the stirring bar is used to mix the solution.
- the magnetic stirrer is switched off during the measurement.

6 Troubleshooting

6.1 General

Problem	Cause	Remedy
Unstable measuring signal - value near zero.	<i>The plug is plugged in incorrectly.</i>	The plug must be plugged in according to the manual (dot to line).
Measured values differ strongly from one another.	<i>The cuvette is missing.</i>	Screw the cuvette on to the 5-ring conductivity measuring cell. Measure only with cuvette!
The measurement signal is influenced by the movement of the 5-ring conductivity measuring cell and/or its position in the measuring vessel.	<i>The cuvette is missing.</i>	Screw the cuvette on to the 5-ring conductivity measuring cell. Measure only with cuvette!

7 Appendix

7.1 Remote interface

The 6.2148.010 Remote Box allows devices to be controlled which cannot be connected directly to the MSB interface of the Conductivity Module.

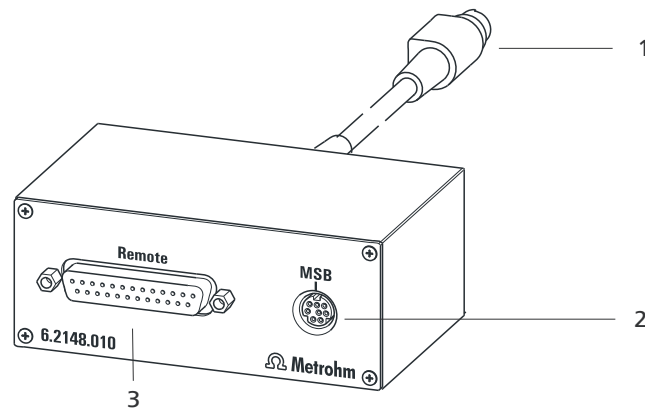

Figure 15 Connectors of the Remote Box

1 Cable

For connecting to the Conductivity Module.

2 MSB connector

Metrohm Serial Bus. For connecting external dosing devices or stirrers.

3 Remote connector

For connecting instruments with a remote interface.

7.1.1 Pin assignment of the remote interface

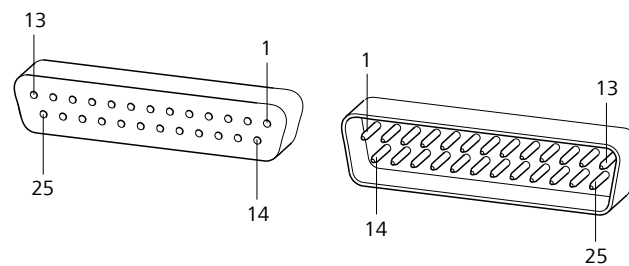
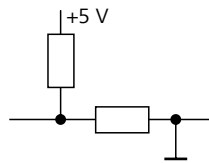

Figure 16 Pin assignment of remote socket and remote plug

The above figure of the pin assignment applies for all Metrohm instruments with 25-pin D-Sub remote connector.

Inputs



approx. 50 k Ω Pull-up

$t_p > 20$ ms

active = low, inactive = high

Outputs

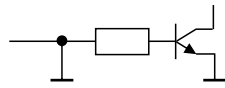

Open Collector

$t_p > 200$ ms

active = low, inactive = high

$I_C = 20$ mA, $V_{CE0} = 40$ V

+5 V: maximum load = 20 mA

The following tables offer information concerning the assignment of the individual pins and their function:

Table 1 Inputs and outputs of the remote interface

Assignment	Pin No.	Function*
Input 0	21	Start
Input 1	9	Stop
Input 2	22	
Input 3	10	Quit
Input 4	23	–
Input 5	11	
Input 6	24	
Input 7	12	
Output 0	5	Ready
Output 1	18	Conditioning OK
Output 2	4	Determination
Output 3	17	EOD
Output 4	3	
Output 5	16	Error
Output 6	1	
Output 7	2	Warning



Assignment	Pin No.	Function*
Output 8	6	
Output 9	7	
Output 10	8	
Output 11	13	
Output 12	19	
Output 13	20	
0 volts / GND	14	
+5 volts	15	
0 volts / GND	25	

* Signal activated only for operation with Touch Control.

Table 2 Explanation of the individual functions

Function	Explanation
Start	The current method is started at the time of activation. $t_{\text{pulse}} > 100 \text{ ms}$
Stop	The current method is canceled (Stop) at the time of activation. $t_{\text{pulse}} > 100 \text{ ms}$
Quit	The current command in the determination run will be canceled at the time of activation. $t_{\text{pulse}} > 100 \text{ ms}$
Ready	The instrument is ready to receive a start signal.
Conditioning OK	The line is set when Conditioning with SET titration and KFT titration is at OK. The line remains set until the determination is started with [START] .
Determination	The instrument performs a data-generating determination.
EOD	End of Determination. Pulse ($t_{\text{pulse}} = 200 \text{ ms}$) after a determination or after a buffer/standard solution during calibration using a Sample Processor.
Error	The line is set for error message display.

Function	Explanation
Warning	The line is set for warning message display.

8.2 Power connection

<i>Supply voltage</i>	100–240 V ($\pm 10\%$)
<i>Frequency</i>	50–60 Hz ($\pm 3\%$)
<i>Power consumption</i>	45 W
<i>Fuse</i>	2 x 1.6 ATH

8.3 Ambient conditions

Automatic interior temperature monitoring

<i>Nominal function range</i>	+5 to +45 °C at max. 80% relative humidity, non-condensing
<i>Storage</i>	+5 to +45 °C at max. 80% relative humidity, non-condensing
<i>Altitude / Pressure range</i>	max. 2,000 m.a.s.l. sea level / min. 780 mbar
<i>Overvoltage category</i>	II
<i>Pollution degree</i>	2

8.4 Reference conditions

<i>Ambient temperature</i>	+25 °C (± 3 °C)
<i>Relative humidity</i>	$\leq 60\%$
<i>Device status</i>	Device in operation at least 30 min
<i>Validity of the data</i>	After adjustment



8.5 Dimensions

<i>Width</i>	142 mm
<i>Height</i>	108 mm
<i>Depth</i>	230 mm
<i>Weight</i>	2.7 kg (without accessories)
<i>Material</i>	Steel sheet

8.6 Interfaces

USB connectors

<i>USB ports</i>	2 USB downstream ports (type A sockets), 500 mA each, for connecting peripheral devices such as printers, keyboards, barcode readers or RS-232/USB boxes (Metrohm order no. 6.2148.020).
------------------	--

"Controller" connector

<i>Controller port</i>	USB upstream port with auxiliary power supply (Mini DIN socket) for connecting Touch Control or computer for controlling the 856 Conductivity Module.
<i>Touch Control</i>	With integrated Touch Control cable.
<i>Computer</i>	With 6.2151.000 cable.

MSB connectors (Metrohm Serial Bus)

<i>Dosing device</i>	Connection of a maximum of 4 external dosing devices, models Dosi-mat or Dosino (MSB 1 to MSB 4).
<i>Stirrer</i>	Connection of a maximum of 4 stirrers. Stirrer control: Switching on/off manually or coordinated with the titration sequence. Speed in 15 steps and shift direction can be selected.
<i>Remote Box</i>	Connection of a maximum of 4 Remote Boxes. Remote Boxes can be used to actuate and monitor external devices.

Index

- 6.2151.000 controller cable 13
 685 Dosimat plus 16
 700 Dosino 16
 800 Dosino 16
 801 Stirrer 17
 803 Ti Stand 17
 804 Ti Stand 17
 805 Dosimat 16
- A**
 ADD 2
 Ambient conditions 33
- B**
 Balance 21
 Barcode reader
 Connect 23
- C**
 Calibration mode
 CAL 2
 Computer
 Connect 13
 Connect
 Balance 21
 Barcode reader 23
 Computer 13
 Dosing device 16
 MSB devices 15
 PC keyboard 22
 Power grid 12
 Printer 20
 Remote Box 18
 Stirrer 17
 Titration stand 17
 Touch Control 11
 USB hub 20
 Connector
 MSB 2
 USB 2
 Controller
 Connector 9
- D**
 Dosing command
 ADD 2
- EMPTY 2
 LQH 2
 PREP 2
 Dosing device
 Connect 16
 Driver software
 Install 13
- E**
 Electrode
 Connect 24
 Electrostatic charge 7
 EMPTY 2
- H**
 Humidity 33
- I**
 Installation
 Driver software 13
 Instrument description 2
 Instrument type 9
- K**
 Keyboard
 Connect 22
- L**
 LQH 2
- M**
 Maintenance 26
 MEAS 2
 Measuring interface 2
 Measuring mode
 MEAS 2
 Metrohm Serial Bus MSB, see also
 "MSB" 15
 MSB
 Connect devices 15
 Connector 9
 MSB connector 2
- O**
 Operation 33
 Overview of the instrument 8
- Overvoltage category 33
- P**
 PC keyboard
 Connect 22
 Pin assignment 28
 Power connection 9, 12, 13
 PREP 2
 Printer 20
- R**
 Remote
 Interface 28
 Pin assignment 28
 Remote Box
 Connect 18
- S**
 Safety instructions 5
 Sea level 33
 Sensor
 Connect 24
 Serial number 9
 Service 6
 Stirrer
 Connect 17
 Storage 33
 Supply voltage 7
 System test 11
- T**
 Temperature 33
 Titration stand
 Connect 17
 Touch Control
 Connect 11
- U**
 USB
 Connector 9
 USB connector 2
 USB hub
 Connect 20