

# 850 Professional IC



Cation – Prep 2 – 2.850.1050

Manual

8.850.8044EN / 2019-12-04





Metrohm AG

CH-9100 Herisau

Switzerland

Phone +41 71 353 85 85

Fax +41 71 353 89 01

[info@metrohm.com](mailto:info@metrohm.com)

[www.metrohm.com](http://www.metrohm.com)

# **850 Professional IC**

## **Cation – Prep 2 – 2.850.1050**

# **Manual**

Technical Communication  
Metrohm AG  
CH-9100 Herisau  
techcom@metrohm.com

This documentation is protected by copyright. All rights reserved.

This documentation has been prepared with great care. However, errors can never be entirely ruled out. Please send comments regarding possible errors to the address above.

# Table of contents

<b>1</b>	<b>Introduction</b>	<b>1</b>
1.1	Instrument description	1
1.2	Intended use	4
1.3	About the documentation	5
1.3.1	Symbols and conventions	5
1.4	Safety instructions	6
1.4.1	General notes on safety	6
1.4.2	Electrical safety	6
1.4.3	Tubing and capillary connections	7
1.4.4	Flammable solvents and chemicals	7
1.4.5	Recycling and disposal	7
<b>2</b>	<b>Installation</b>	<b>9</b>
2.1	About this chapter	9
2.2	Initial installation	9
2.3	Flow diagram	10
2.4	Setting up the instrument	16
2.4.1	Packaging	16
2.4.2	Checks	16
2.4.3	Location	16
2.5	Capillary connections in the IC system	17
2.6	Rear of the instrument	19
2.6.1	Rollers and handle	19
2.6.2	Positioning and connecting the detector	22
2.6.3	Transport locking screws	22
2.6.4	Leak sensor	22
2.6.5	Drainage tubings	23
2.7	Capillary and cable feed-throughs	25
2.8	Eluent	28
2.8.1	Connecting the eluent bottle	28
2.9	Eluent degasser	32
2.10	High pressure pump	34
2.10.1	Capillary connections high pressure pump/purge valve	34
2.10.2	Deaerating the high pressure pump	36
2.11	Inline filter	38
2.12	Pulsation absorber	39
2.13	Sample degasser	40



<b>2.14</b>	<b>Peristaltic pump</b> .....	<b>42</b>
2.14.1	Principle of the peristaltic pump .....	42
2.14.2	Installing the peristaltic pump .....	43
<b>2.15</b>	<b>Injection valve</b> .....	<b>47</b>
2.15.1	Connecting the injection valve .....	47
2.15.2	Mode of operation of the injection valve .....	48
2.15.3	Selecting the sample loop .....	49
<b>2.16</b>	<b>Column thermostat</b> .....	<b>49</b>
<b>2.17</b>	<b>Conductivity detector</b> .....	<b>52</b>
<b>2.18</b>	<b>Connecting the instrument to a computer</b> .....	<b>54</b>
<b>2.19</b>	<b>Connecting the instrument to the power grid</b> .....	<b>55</b>
<b>2.20</b>	<b>Guard column</b> .....	<b>56</b>
<b>2.21</b>	<b>Separation column</b> .....	<b>57</b>
<b>3</b>	<b>Start-up</b> .....	<b>60</b>
3.1	Initial start-up .....	60
3.2	Conditioning .....	61
<b>4</b>	<b>Operation and maintenance</b> .....	<b>63</b>
<b>4.1</b>	<b>General notes</b> .....	<b>63</b>
4.1.1	Care .....	63
4.1.2	Maintenance by Metrohm Service .....	63
4.1.3	Operation .....	64
4.1.4	Shutting down .....	64
<b>4.2</b>	<b>Capillary connections</b> .....	<b>64</b>
4.2.1	Operation .....	64
<b>4.3</b>	<b>Door</b> .....	<b>65</b>
<b>4.4</b>	<b>Eluent</b> .....	<b>65</b>
4.4.1	Production .....	65
4.4.2	Operation .....	66
<b>4.5</b>	<b>High pressure pump</b> .....	<b>66</b>
4.5.1	Protection .....	66
4.5.2	Maintenance .....	67
<b>4.6</b>	<b>Inline filter</b> .....	<b>77</b>
4.6.1	Maintenance .....	77
<b>4.7</b>	<b>Inline sample preparation</b> .....	<b>79</b>
<b>4.8</b>	<b>Rinsing the sample path</b> .....	<b>79</b>
<b>4.9</b>	<b>Sample degasser</b> .....	<b>81</b>
4.9.1	Operation .....	81
<b>4.10</b>	<b>Peristaltic pump</b> .....	<b>81</b>
4.10.1	Operation .....	81

4.10.2	Maintenance .....	82
<b>4.11</b>	<b>Injection valve .....</b>	<b>84</b>
4.11.1	Protection .....	84
<b>4.12</b>	<b>Conductivity detector .....</b>	<b>84</b>
4.12.1	Maintenance .....	84
<b>4.13</b>	<b>Separation column .....</b>	<b>85</b>
4.13.1	Separating efficiency .....	85
4.13.2	Protection .....	85
4.13.3	Storage .....	85
4.13.4	Regeneration .....	86
<b>5</b>	<b>Troubleshooting .....</b>	<b>87</b>
5.1	Problems and their solutions .....	87
<b>6</b>	<b>Technical specifications .....</b>	<b>91</b>
6.1	Reference conditions .....	91
6.2	Device .....	91
6.3	Leak sensor .....	91
6.4	Ambient conditions .....	91
6.5	Housing .....	92
6.6	Eluent degasser .....	92
6.7	High pressure pump .....	92
6.8	Sample degasser .....	93
6.9	Peristaltic pump .....	93
6.10	Injection valve .....	94
6.11	Column thermostat .....	94
6.12	Conductivity measuring system .....	94
6.13	Power connection .....	95
6.14	Interfaces .....	95
6.15	Weight .....	96
<b>7</b>	<b>Accessories .....</b>	<b>97</b>
	<b>Index .....</b>	<b>98</b>



## Table of figures

Figure 1	Front view of the instrument .....	2
Figure 2	Flow diagram for matrix elimination with transfer procedure .....	12
Figure 3	Flow diagram for standard addition with preconcentration. ....	15
Figure 4	Connection of capillaries with pressure screws .....	17
Figure 5	Rollers and handle .....	20
Figure 6	Handle as MPak holder .....	21
Figure 7	Connection of the leak sensor on the rear of the instrument .....	23
Figure 8	Drainage tubings .....	24
Figure 9	Capillary feed-throughs on the door .....	26
Figure 10	Capillary feed-throughs base tray/flask holder .....	27
Figure 11	Installing the eluent bottle cap .....	29
Figure 12	Mounting the aspiration filter .....	29
Figure 13	Installing the tubing weighting and aspiration filter .....	30
Figure 14	Eluent aspiration tubing fully equipped .....	30
Figure 15	Eluent bottle – connected .....	31
Figure 16	Eluent degasser .....	33
Figure 17	Capillary connections high pressure pump/purge valve .....	34
Figure 18	High pressure pump – Connect inlet .....	35
Figure 19	Deaerate the high pressure pump .....	37
Figure 20	Connecting the inline filter .....	39
Figure 21	Pulsation absorber – Connection .....	40
Figure 22	Sample degasser .....	41
Figure 23	Peristaltic pump .....	42
Figure 24	Installing the pump tubing .....	43
Figure 25	Install pump tubing connection with filter .....	44
Figure 26	Install pump tubing connection without filter .....	45
Figure 27	Injection valve – connected .....	47
Figure 28	Injection valve – Positions .....	48
Figure 29	Column thermostat .....	50
Figure 30	Conductivity detector front .....	52
Figure 31	Conductivity detector rear .....	53
Figure 32	Connection detector – separation column .....	54
Figure 33	Pump head – removing the piston .....	68
Figure 34	Components of the piston cartridge .....	69
Figure 35	Tool for piston seal .....	70
Figure 36	Removing the piston seal .....	71
Figure 37	Inserting the piston seal into the tool .....	71
Figure 38	Inserting the piston seal into the pump head .....	72
Figure 39	Removing valves .....	73
Figure 40	Dismantling valve .....	74
Figure 41	Components of the inlet valve and outlet valve .....	75
Figure 42	Change filters (of the inline filter) .....	77
Figure 43	Pump tubing connection – Changing the filter .....	83

# 1 Introduction

## 1.1 Instrument description

The instrument **850 Professional IC – Cation – Prep 2** (2.850.1050) is one of the model versions of the Professional IC line of instruments manufactured by the Metrohm Company. The Professional IC line of instruments is distinguished by

- the **intelligence** of its components, which are able to monitor and optimize all functions and to provide documentation according to FDA requirements.
- its **compactness**.
- its **flexibility**. A suitable model version exists for every application. Individual instruments can be converted, expanded or modified to create a different instrument as needed.
- its **transparency**. All components are easily accessible and arranged in a clear manner.
- its **safety**. Chemicals and electronics are separated and a leak sensor is integrated in the wet end.
- its **environmental compatibility**.
- **low noise emission**.

The instrument is operated with **MagIC Net** software. It is connected via a USB connection to a PC on which MagIC Net is installed. The software automatically recognizes the instrument and checks its functional readiness. MagIC Net controls and monitors the instrument, evaluates the measured data and administers it in a database. The operation of MagIC Net is described in the online help or in the tutorial for MagIC Net.

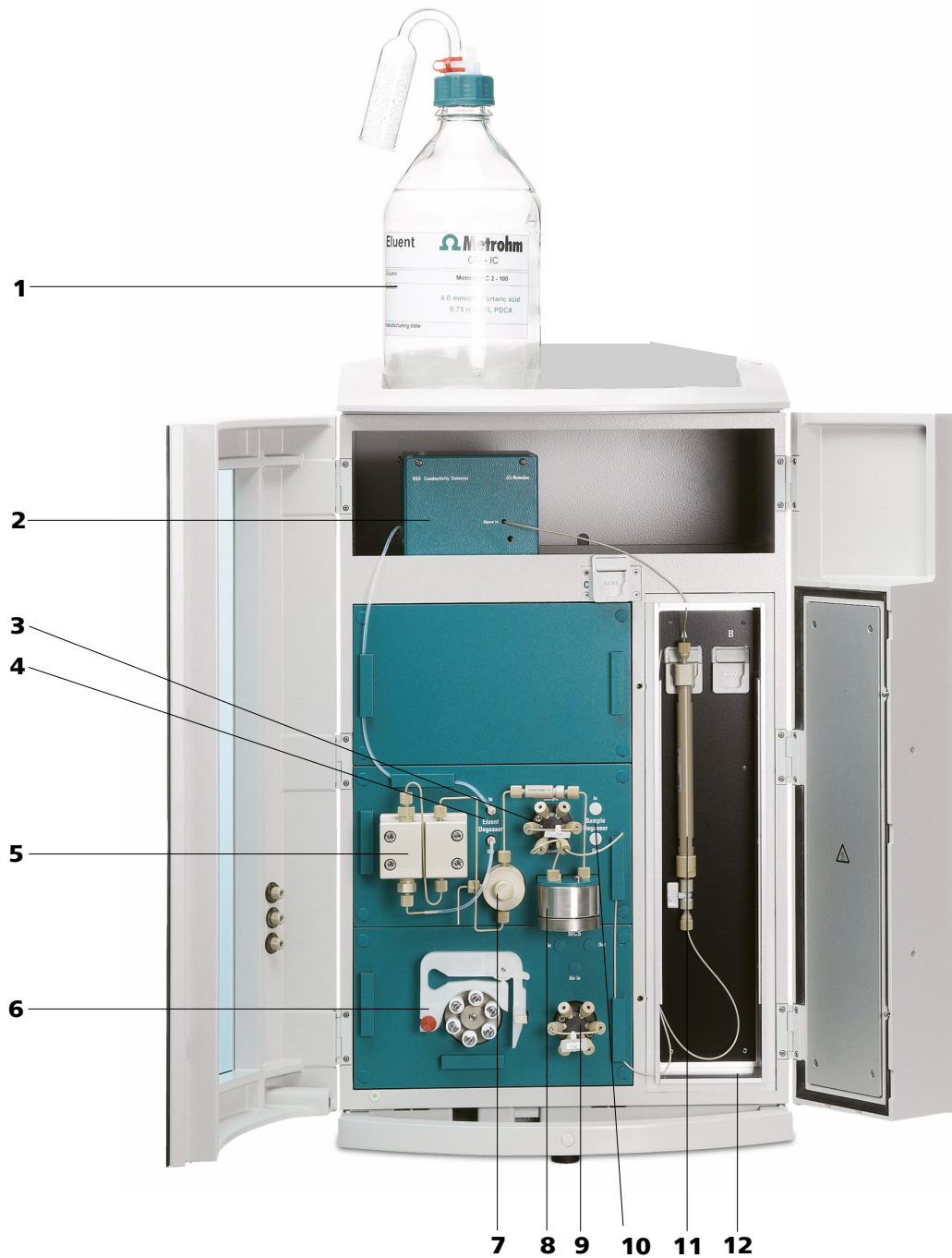

Figure 1 Front view of the instrument

**1 Eluent bottle**  
See Chapter 2.8.1.

**2 Conductivity detector**  
See Chapter 2.17.

<b>3</b>	<b>Injection valve</b> <i>See Chapter 2.15.</i>	<b>4</b>	<b>Eluent degasser</b> <i>See Chapter 2.9.</i>
<b>5</b>	<b>High pressure pump</b> <i>See Chapter 2.10.</i>	<b>6</b>	<b>Peristaltic pump</b> <i>See Chapter 2.14.</i>
<b>7</b>	<b>Purge valve</b> <i>See Chapter 2.10.1.</i>	<b>8</b>	<b>Pulsation damper</b> <i>See Chapter 2.12.</i>
<b>9</b>	<b>Injection valve</b> For sample preparation. <i>See Chapter 2.15.</i>	<b>10</b>	<b>Sample degasser</b> <i>See Chapter 2.13. Use optional.</i>
<b>11</b>	<b>Separation column</b> <i>See Chapter 2.21.</i>	<b>12</b>	<b>Column thermostat</b> <i>See Chapter 2.16.</i>

The instrument contains the following components:

### **Eluent degasser**

The eluent degasser removes gas bubbles and dissolved gases from the eluent. For degassing, the eluent flows into a vacuum chamber through a special fluoropolymer capillary.

### **High pressure pump**

The intelligent and low pulsation high pressure pump pumps the eluent through the system. It is equipped with a chip on which its technical specifications and "life history" (operating hours, service data, ...) are saved.

### **Inline filter**

Inline filters protect the separation column securely against possible contamination from the eluent. Inline filters can however also just as well be used for the purpose of protecting other sensitive components against contaminations in the solutions used. The filter platelets with a pore size of 2 µm can be replaced quickly and easily. They remove particles like e. g. bacteria and algae from the solutions.

### **Pulsation absorber**

The pulsation absorber protects the separation column from damage caused by pressure fluctuations when switching the injection valve, and reduces interfering pulsations during highly sensitive measurements.

### **Sample degasser**

The sample degasser removes gas bubbles and dissolved gases from the sample. For degassing, the sample flows into a vacuum chamber through a special fluoropolymer capillary.

### **Peristaltic pump**

The Peristaltic pump is used for pumping sample and auxiliary solutions. It can rotate in both directions.



### **Injection valve**

The injection valve connects the eluent and sample path through rapid and precise valve switchover. A precisely measured amount of sample solution is injected and rinsed with eluent onto the separation column.

### **Column thermostat**

The column thermostat controls the temperature of the column and eluent channel and thus ensures stable measuring conditions. It provides space for 2 separation columns.

### **Conductivity detector**

The conductivity detector continuously measures the conductivity of the liquid passing through and indicates these signals in digital form (DSP – Digital Signal Processing). The conductivity detector exhibits outstanding thermal stability and thus guarantees reproducible measuring conditions.

### **Separation column**

The intelligent separation column is the heart of the ion chromatographic analysis. It separates the different components corresponding to their interactions with the column. Metrohm separation columns are equipped with a chip on which their technical specifications and their history (first use / setting up, operating hours, injections, ...) are saved.

## **1.2 Intended use**

The **850 Professional IC – Cation – Prep 2** is used for the ion chromatographic determination of cations and anions (without suppression).

The peristaltic pump and the **additional injection valve** in the lower area of the instrument are used for inline sample preparation and calibration techniques – e.g. *Matrix elimination with transfer procedure* or *Standard addition with preconcentration*.

For sample dilution Metrohm offers a special equipment (6.5330.020).

The present instrument is suitable for processing chemicals and flammable samples. The usage of the 850 Professional IC – Cation – Prep 2 therefore requires that the user has basic knowledge and experience in the handling of toxic and caustic substances. Knowledge with respect to the application of the fire prevention measures prescribed for laboratories is also mandatory.

## 1.3 About the documentation









### CAUTION

Please read through this documentation carefully before putting the instrument into operation. The documentation contains information and warnings which have to be followed by the user in order to ensure safe operation of the instrument.

### 1.3.1 Symbols and conventions

The following symbols and styles are used in this documentation:

(5-12)	<p><b>Cross-reference to figure legend</b></p> <p>The first number refers to the figure number, the second to the instrument part in the figure.</p>
1	<p><b>Instruction step</b></p> <p>Carry out these steps in the sequence shown.</p>
	<p><b>Warning</b></p> <p>This symbol draws attention to a possible life hazard or risk of injury.</p>
	<p><b>Warning</b></p> <p>This symbol draws attention to a possible hazard due to electrical current.</p>
	<p><b>Warning</b></p> <p>This symbol draws attention to a possible hazard due to heat or hot instrument parts.</p>
	<p><b>Warning</b></p> <p>This symbol draws attention to a possible biological hazard.</p>
	<p><b>Caution</b></p> <p>This symbol draws attention to a possible damage of instruments or instrument parts.</p>
	<p><b>Note</b></p> <p>This symbol marks additional information and tips.</p>



## 1.4 Safety instructions

### 1.4.1 General notes on safety



#### WARNING

---

Operate this instrument only according to the information contained in this documentation.

This instrument left the factory in a flawless state in terms of technical safety. To maintain this state and ensure non-hazardous operation of the instrument, the following instructions must be observed carefully.

### 1.4.2 Electrical safety

The electrical safety when working with the instrument is ensured as part of the international standard IEC 61010.



#### WARNING

---

Only personnel qualified by Metrohm are authorized to carry out service work on electronic components.



#### WARNING

---

Never open the housing of the instrument. The instrument could be damaged by this. There is also a risk of serious injury if live components are touched.

There are no parts inside the housing which can be serviced or replaced by the user.

#### Supply voltage



#### WARNING

---

An incorrect supply voltage can damage the instrument.

Only operate this instrument with a supply voltage specified for it (see rear panel of the instrument).

## Protection against electrostatic charges



### WARNING

Electronic components are sensitive to electrostatic charges and can be destroyed by discharges.

Do not fail to pull the power cord out of the power socket before you set up or disconnect electrical plug connections at the rear of the instrument.

### 1.4.3 Tubing and capillary connections



### CAUTION

Leaks in tubing and capillary connections are a safety risk. Tighten all connections well by hand. Avoid applying excessive force to tubing connections. Damaged tubing ends lead to leakage. Appropriate tools can be used to loosen connections.

Check the connections regularly for leakage. If the instrument is used mainly in unattended operation, then weekly inspections are mandatory.

### 1.4.4 Flammable solvents and chemicals



### WARNING

All relevant safety measures are to be observed when working with flammable solvents and chemicals.

- Set up the instrument in a well-ventilated location (e.g. fume cupboard).
- Keep all sources of flame far from the workplace.
- Clean up spilled liquids and solids immediately.
- Follow the safety instructions of the chemical manufacturer.

### 1.4.5 Recycling and disposal

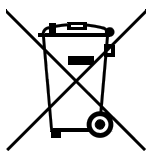

This product is covered by European Directive 2012/19/EU, WEEE – Waste Electrical and Electronic Equipment.

The correct disposal of your old instrument will help to prevent negative effects on the environment and public health.



More details about the disposal of your old instrument can be obtained from your local authorities, from waste disposal companies or from your local dealer.

## 2 Installation

### 2.1 About this chapter

The *Installation* chapter contains

- a list of all the steps to be carried out during the initial installation (*see chapter 2.2, page 9*).
- a schematic overview of the flow paths (*see chapter 2.3, page 10*).
- a description of the construction, connections and functionality of the instrument.
- step-by-step installation instructions. A part of these installation tasks has already been carried out before delivery. They are nevertheless described here in case they need to be carried out once again some time in the future (e.g. after maintenance of the high pressure pump).

### 2.2 Initial installation



#### NOTICE

A large number of the capillary connections are already connected at the time the instrument is delivered.

The following steps still have to be carried out after delivery:

- 1** Setting up the instrument (*see chapter 2.4, page 16*).
- 2** Remove handle and rollers (*see chapter 2.6.1, page 19*).
- 3** Place the detectors in the instrument and connect them (*see chapter 2.6.2, page 22*).
- 4** Remove transport locking screws (*see chapter 2.6.3, page 22*).
- 5** Connect the leak sensor (*see chapter 2.6.4, page 22*).
- 6** Connect drainage tubings (*see chapter 2.6.5, page 23*).
- 7** Connect the eluent bottle (*see chapter 2.8.1, page 28*).



- 8** Install sample path connections.
  - Connect the sample degasser (if required) (*see chapter 2.13, page 40*).
  - Installing sample preparation (*see chapter 2.3, page 10*).
  - Connect sample path connections to the injection valve (*see chapter 2.15.2, page 48*).
- 9** Connect detector capillaries (*see chapter 2.17, page 52*).
- 10** Mains connection .
- 11** Connect the instrument to the PC .
- 12** Initial start-up (*see chapter 3.1, page 60*).
- 13** Install the guard column (if used) (*see chapter 2.20, page 56*).
- 14** Install the separation column (*see chapter 2.21, page 57*).

## 2.3 Flow diagram

*Figure 2 Flow diagram for matrix elimination with transfer procedure and Figure 3 Flow diagram for standard addition with preconcentration.* show the flow paths for two with the 2.850.1050 performable analysis technologies. The arrangement of the modules in the diagram corresponds to the front view of the instrument. Liquid containers (eluent bottle, sample vessel, waste container, auxiliary solutions container) and guard column (*see chapter 2.20, page 56*) are not shown in the diagram. Which pressure screws, connections and couplings are used, is described in the installation chapters of the individual modules.

### **Matrix elimination with transfer procedure**

This sample preparation technology is applied when the sample matrix could damage the separation columns (and the analyte ion content is in the ppm range).

For this, a small, defined sample amount is measured at an additional injection valve (2-**12**) and pumped with a transfer solution (ultra pure water) to the preconcentration column (2-**17**) at the injection valve (2-**7**). The sample is retained by preconcentration column, while the matrix is rinsed into the drain with the transfer solution. After a predefined time, the injection valve (2-**7**) is switched to **<Inject>** and data recording is



started. The sample retained on the preconcentration column (2-**17**) is now rinsed with the eluent onto the separation column.

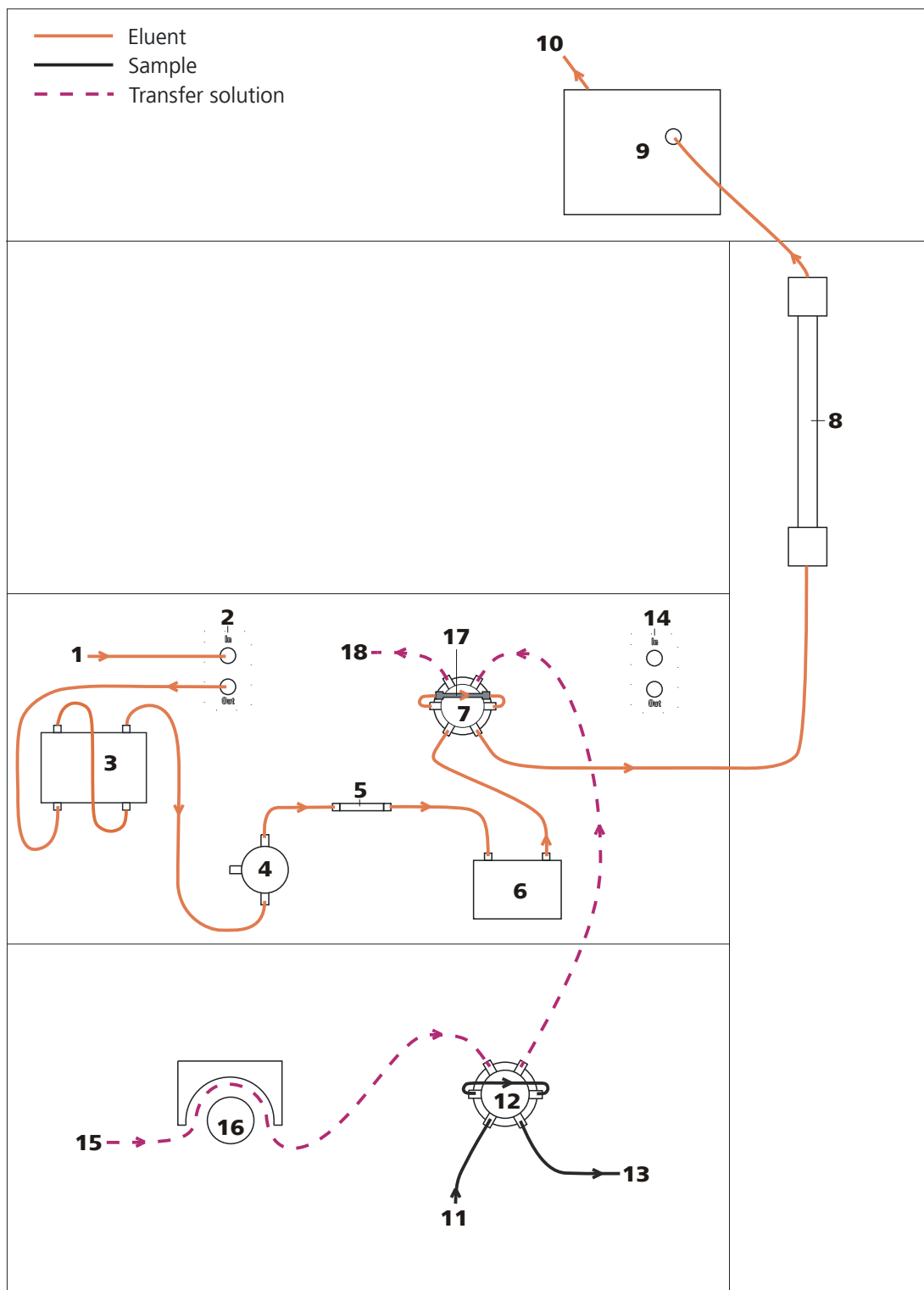

Figure 2 Flow diagram for matrix elimination with transfer procedure

**1 Eluent input**  
 Connection to the eluent bottle (see chapter 2.8.1, page 28).

**2 Eluent degasser**  
 See Chapter 2.9.

<b>3 High pressure pump</b> <i>See Chapter 2.10.</i>	<b>4 Purge valve</b> <i>See Chapter 2.10.1.</i>
<b>5 Inline filter</b> <i>See Chapter 2.11.</i>	<b>6 Pulsation damper</b> <i>See Chapter 2.12.</i>
<b>7 Injection valve</b> <i>See Chapter 2.15.</i>	<b>8 Separation column</b> <i>See Chapter 2.21.</i> When a guard column ( <i>see chapter 2.20, page 56</i> ) is used, it is installed between injection valve and separation column.
<b>9 Detector</b> <i>See Chapter 2.17.</i>	<b>10 Eluent output</b> Connection to the waste container.
<b>11 Sample input</b>	<b>12 Injection valve</b> For sample preparation. <i>See Chapter 2.15.</i>
<b>13 Sample output</b>	<b>14 Sample degasser</b> <i>See Chapter 2.13.</i> Use optional.
<b>15 Transfer solution inlet</b> Connection to transfer solution container.	<b>16 Peristaltic pump</b> Pumps the transfer solution. <i>See Chapter 2.14.</i>
<b>17 Preconcentration column</b> For sample preconcentration.	<b>18 Transfer solution outlet</b> Connection to the waste container.

### Standard addition with preconcentration

It is often the case that there are no certified standards available for complicated sample matrices. "Standard addition with preconcentration" technology can be applied in order to prevent adulterations of the analysis results caused by the matrix.

Procedure:

#### 1 Sample measurement

The sample is rinsed for a defined time period onto the preconcentration column (**3-13**) at the injection valve (**3-7**) and retained there. Then the injection valve (**3-7**) is switched to **<Inject>** and data recording is started. The eluent carries along the sample retained on the preconcentration column (**3-13**) to the separation column.

#### 2 1. Standard addition



#### NOTICE

The sample path should be rinsed between measurements.



Analogous to Step 1, but an additional defined amount of standard solution is rinsed onto the preconcentration column (3-**13**) at the injection valve (3-**7**) after the sample. The amount of standard solution is measured at the additional injection valve (3-**12**) and injected into the sample path (one injection corresponds to calibration level 1).

**3 2. Standard addition**

Similar to Step 2, but with twice the amount of standard solution (two injections correspond to calibration level 2).

**4 X. Standard addition**

Carry out the amount of standard additions required.

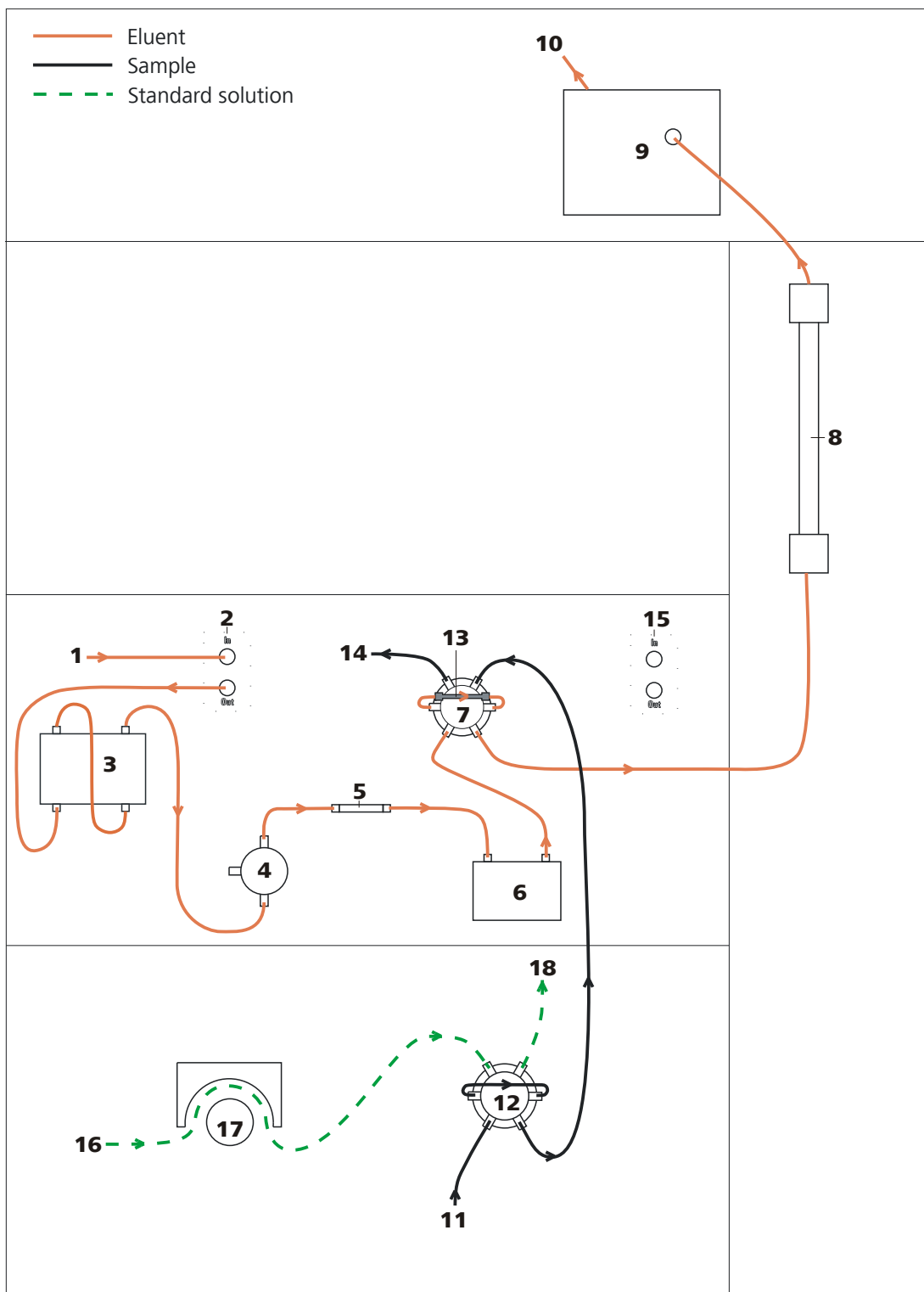

Figure 3 Flow diagram for standard addition with preconcentration.

**1 Eluent input**

Connection to the eluent bottle (see chapter 2.8.1, page 28).

**2 Eluent degasser**

See Chapter 2.9.



<b>3 High pressure pump</b> <i>See Chapter 2.10.</i>	<b>4 Purge valve</b> <i>See Chapter 2.10.1.</i>
<b>5 Inline filter</b> <i>See Chapter 2.11.</i>	<b>6 Pulsation damper</b> <i>See Chapter 2.12.</i>
<b>7 Injection valve</b> <i>See Chapter 2.15.</i>	<b>8 Separation column</b> <i>See Chapter 2.21.</i> When a guard column ( <i>see chapter 2.20, page 56</i> ) is used, it is installed between injection valve and separation column.
<b>9 Detector</b> <i>See Chapter 2.17.</i>	<b>10 Eluent output</b> Connection to the waste container.
<b>11 Sample input</b> Connection to the sample vessel.	<b>12 Injection valve</b> For sample preparation. <i>See Chapter 2.15.</i>
<b>13 Preconcentration column</b> For sample preconcentration.	<b>14 Sample output</b>
<b>15 Sample degasser</b> <i>See Chapter 2.13.</i> Use optional.	<b>16 Standard solution inlet</b> Connection to the standard solution container.
<b>17 Peristaltic pump</b> Pumps the standard solution. <i>See Chapter 2.14.</i>	<b>18 Standard solution outlet</b> Connection to the waste container.

## 2.4 Setting up the instrument

### 2.4.1 Packaging

The instrument is supplied in protective packaging together with the separately packed accessories. Keep this packaging, as only this ensures safe transportation of the instrument.

### 2.4.2 Checks

Immediately after receipt, check whether the shipment has arrived complete and without damage by comparing it with the delivery note.

### 2.4.3 Location

The instrument has been developed for operation indoors and may not be used in explosive environments.

Place the instrument in a location of the laboratory which is suitable for operation and free of vibrations and which provides protection against corrosive atmosphere and contamination by chemicals.

The instrument should be protected against excessive temperature fluctuations and direct sunlight.

## 2.5 Capillary connections in the IC system

This chapter contains general information concerning the capillary connections in the IC instruments and systems.

Generally speaking, capillary connections between two components of an IC system are made up of one connection capillary and two pressure screws with which the capillary is connected to the respective components.

### Pressure screws

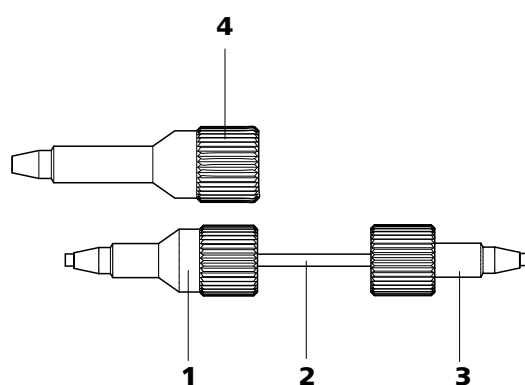

Figure 4 Connection of capillaries with pressure screws

#### 1 PEEK pressure screw (6.2744.014)

Use on the injection valve.

#### 2 Connection capillary

#### 3 PEEK pressure screw, short (6.2744.070)

For use on the high pressure pump, the purge valve, the inline filter, the pulsation absorber, the guard column and the separation column.

#### 4 PEEK pressure screw, long (6.2744.090)

Use on special components. Is not used on all instruments.



#### NOTICE

In order to keep the dead volume as low as possible, capillary connections should generally be as short as possible.



#### NOTICE

For an improved overview, capillary and tubing connections can be bundled with the 6.1815.010 spiral band.



### Connection capillaries

PEEK capillaries and PTFE capillaries are used in the IC system.

*PEEK capillaries (poly-etheretherketone)*

PEEK capillaries are temperature-resistant up to 100°C, stable under pressure up to 400 bar, flexible, chemically inert and exhibit an extremely smooth surface. They can be readily cut down to the desired length with the 6.2621.080 capillary cutter.

Usage:

- PEEK capillaries (6.1831.010) with an internal diameter of 0.25 mm for the entire high-pressure section.
- PEEK capillaries (6.1831.030) with an internal diameter of 0.75 mm for sample handling in the ultratrace range.



#### CAUTION

For the capillary connections between the injection valve and detector, PEEK capillaries with an internal diameter of 0.25 mm must be used. These are already connected to a newly delivered instrument.

*PTFE capillaries (poly-tetrafluoroethylene)*

PTFE capillaries are transparent and enable visual tracing of the liquids to be pumped. They are chemically inert, flexible and temperature-resistant up to 80°C.

Usage:

PTFE capillaries (6.1803.0x0) are used for the low-pressure section.

- PTFE capillaries with internal diameter of 0.5 mm for sample handling.
- PTFE capillaries with internal diameter of 0.97 mm for sample handling as well as for rinsing solutions (they do not have to be in the scope of delivery of the instrument).

### Capillary connections

In order to achieve optimum analysis results, capillary connections in an IC system must be absolutely tight and free of dead volume. Dead volume occurs if two capillary ends connected to each other do not fit exactly, thus allowing liquid to escape. There are two possible reasons for this:

- The capillaries do not have exactly cut edges.
- The two capillary ends do not completely meet.

One prerequisite for dead volume free capillary connection is, that both capillary ends are cut exactly plane. Therefore we recommend only to cut PEEK capillaries with the capillary cutter (6.2621.080).

### Creating dead volume free capillary connections

To create dead volume free capillary connections, proceed as follows:

- 1 Slide the pressure screw over the capillary. Ensure that the capillary protrudes 1–2 mm from the tip of the pressure screw.
- 2 Plug the capillary all the way into the connection or coupling until the stop.
- 3 Only then start turning the pressure screw, while keeping the capillary pressed in space.

### Colored sleeves for PEEK capillaries

The enclosed set of varicolored sleeves for PEEK capillaries (6.2251.000) serves to easily differentiate the various flows of liquid in the system through color coding. Each capillary leading a given liquid (e. g. eluent) can be highlighted with sleeves of the same color.

To highlight a capillary, proceed as follows:

- 1 Slide a sleeve of a selected color over a capillary and move it to an easily visible position.

If the capillary heats up, the sleeve shrinks and adapts to the form of the capillary.

## 2.6 Rear of the instrument

### 2.6.1 Rollers and handle

In order to make transport easier, the instrument is equipped with rollers and a handle.

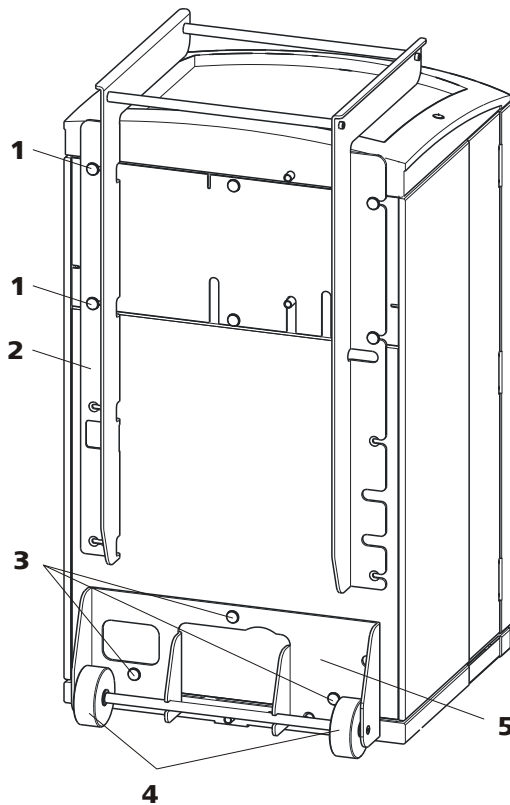

Figure 5 Rollers and handle

<p><b>1 Knurled screws</b> For fastening the handle (5-2) and the rear panel of the detector chamber.</p>	<p><b>2 Handle</b></p>
<p><b>3 Knurled screws</b> For fastening the roller holder (5-5).</p>	<p><b>4 Rollers</b></p>
<p><b>5 Roller holder</b></p>	

**Removing handle**

- 1 Loosen knurled screws (5-1) and remove handle (5-2).

**Removing rollers**

Proceed as follows to remove the rollers:

- 1 Remove knurled screws (5-3).
- 2 Remove roller holder (5-5).

## Mounting handle as MPak holder



### NOTICE

When extended, the handle (6-2) can also be used for hanging up MPaks (eluent bags).

- 1 Move handle (6-2) upwards and screw in the knurled screws (6-1) again.

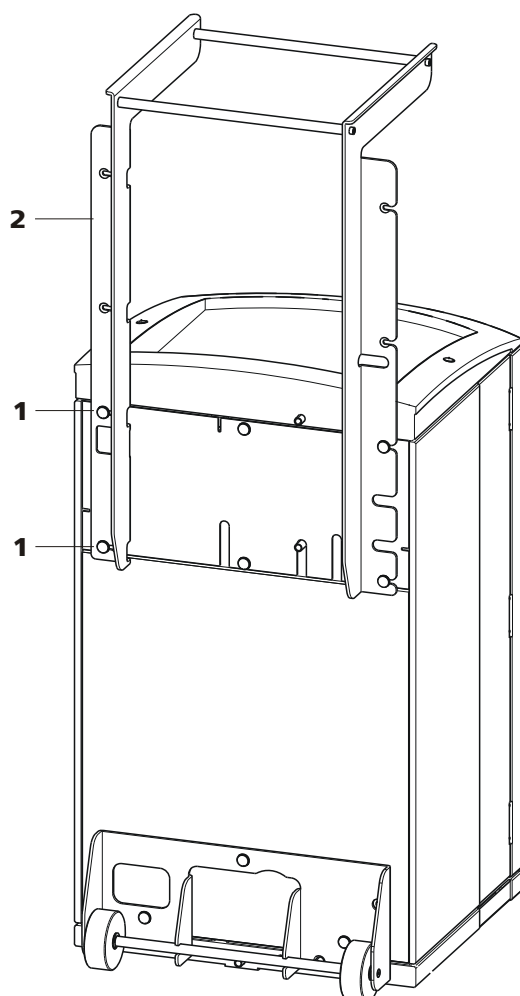

Figure 6 Handle as MPak holder

#### 1 Knurled screws

For fastening the handle (6-2) and the rear panel of the detector chamber.

#### 2 Handle

Extended. As holder for MPaks (eluent bag).



### 2.6.2 Positioning and connecting the detector

The instrument is delivered without detector. For information on how to place and connect the detector, please refer to the manual of the detector.

### 2.6.3 Transport locking screws

To avoid damage to the high pressure pump and the vacuum pump during transport, the pumps are secured with transport locking screws.

Remove these transport locking screws before the initial start-up.

#### Removing transport locking screws

- 1 Remove all of the transport locking screws with the 4 mm hexagon key (6.2621.030) and keep them in a safe place.



#### WARNING

In order to avoid damage to the pumps, the transport locking screws must be remounted each time the instrument undergoes major transport.

### 2.6.4 Leak sensor

The leak sensor detects escaping liquid which collects in the base tray of the instrument.

To activate the leak sensor, the leak sensor connector plug (7-2) must be connected, the instrument switched on and the leak sensor switched to **active** in the software.

#### Connecting the leak sensor

- 1 Plug the leak sensor connector plug (7-2) into the leak sensor connection socket (7-1) on the rear of the instrument (*see figure 7, page 23*).

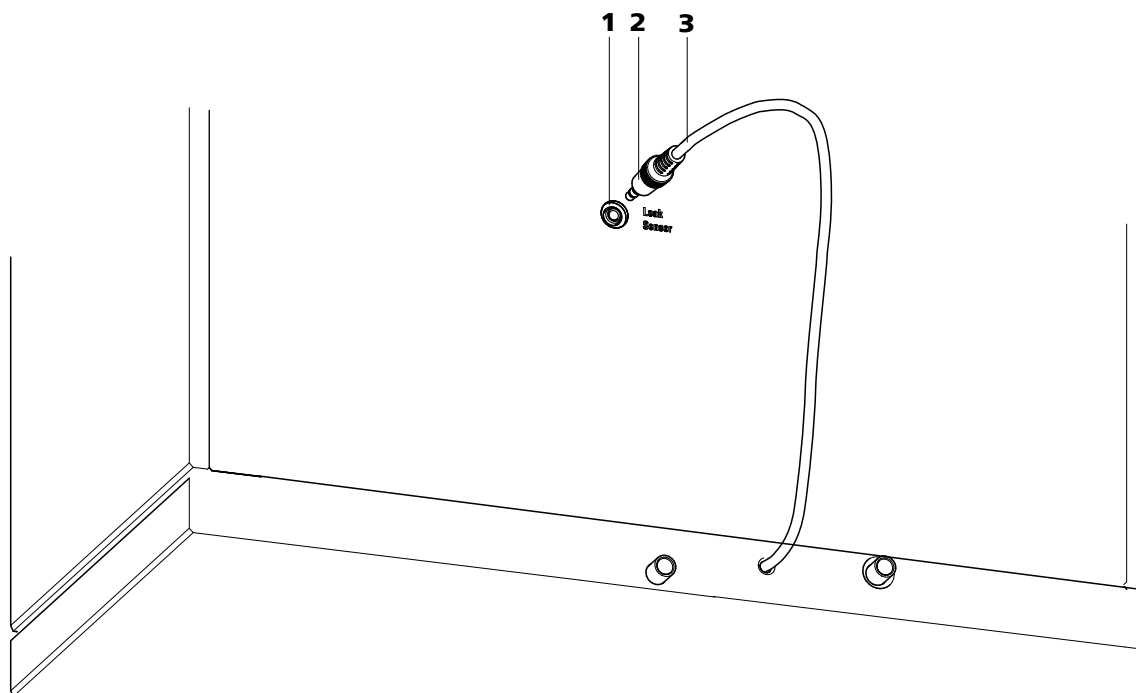

Figure 7 Connection of the leak sensor on the rear of the instrument

**1 Leak sensor connection socket**

Is labeled with "Leak Sensor".

**2 Leak sensor connector plug**

**3 Leak sensor connection cable**

Is firmly mounted on the rear of the instrument.

### 2.6.5 Drainage tubings

Liquid that escapes in the flask holder or in the detector chamber is directed through the drainage tubings into the base tray, past the leak sensor into the waste container. This ensures that any leaks in the system will be detected by the leak sensor.

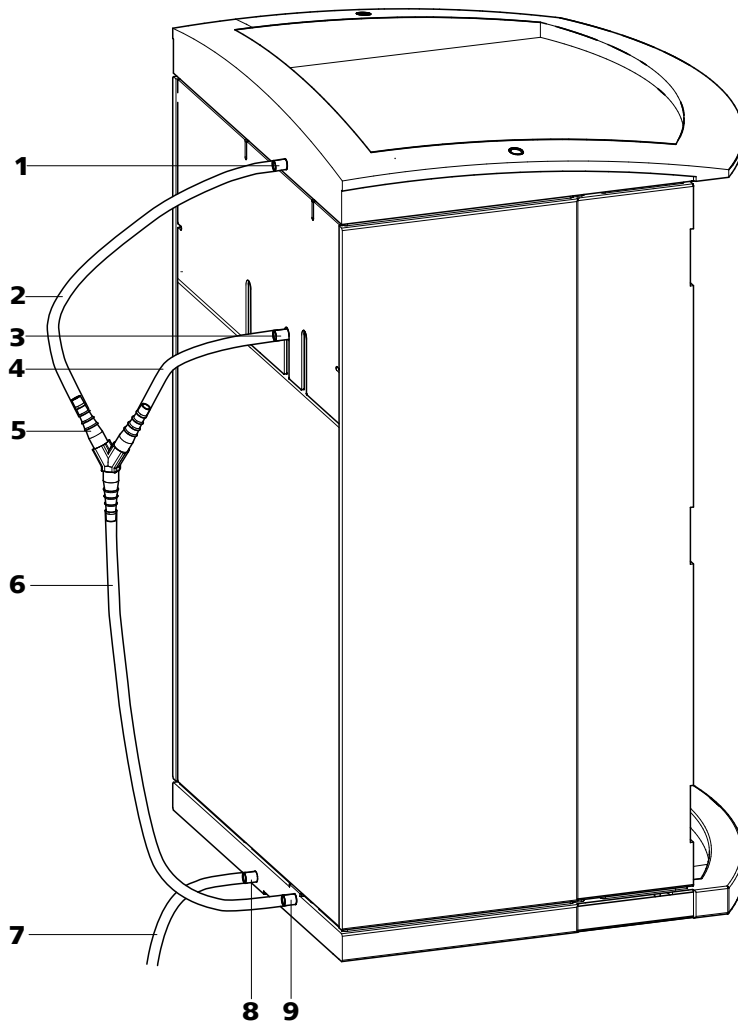

Figure 8 Drainage tubings

<p><b>1 Drainage tubing connector</b> For draining escaped liquid from the flask holder.</p>	<p><b>2 Drainage tubing</b> Section of the 6.1816.020 silicon tubing. For draining escaped liquid from the flask holder.</p>
<p><b>3 Drainage tubing connector</b> For draining escaped liquid from the detector chamber.</p>	<p><b>4 Drainage tubing</b> Section of the 6.1816.020 silicon tubing. For draining escaped liquid from the detector chamber.</p>
<p><b>5 Y connector 6.1807.010</b> For connecting the two drainage tubings (8-2) and (8-4).</p>	<p><b>6 Drainage tubing</b> Section of the 6.1816.020 silicon tubing. Guides escaped liquid to the leak sensor.</p>

**7 Drainage tubing**

Section of the 6.1816.020 silicon tubing. Guides escaped liquid into a waste container.

**9 Drainage tubing connector**

For supplying escaped liquid through the connected drainage tubing to the leak sensor.

**8 Drainage tubing connector**

For draining the escaped liquid from the base tray through the connected drainage tubing.

Proceed as follows to install the drainage tubings:

**Installing drainage tubings**

- 1** Plug drainage tubing (8-2) into the drainage tubing connector (8-1) of the flask holder and shorten to required length.
- 2** Plug drainage tubing (8-4) into the drainage tubing connector (8-3) of the detector chamber and shorten to required length.
- 3** Connect drainage tubing (8-2) from the flask holder and drainage tubing (8-4) from the detector chamber to the Y connector (8-5).
- 4** Connect drainage tubing (8-6) to the Y connector (8-5), shorten to required length and plug the other end of the drainage tubing into the drainage tubing connector (8-9) of the base tray.
- 5** Plug drainage tubing (8-7) into the drainage tubing connector (8-8) of the base tray and guide the other end into a waste container.

## 2.7 Capillary and cable feed-throughs

Several openings have been integrated for feeding through capillaries and cables. They are located on the doors (*see figure 9, page 26*), on the rear panel or below the flask holder or above the base tray (*see Figure 10, Page 27*).

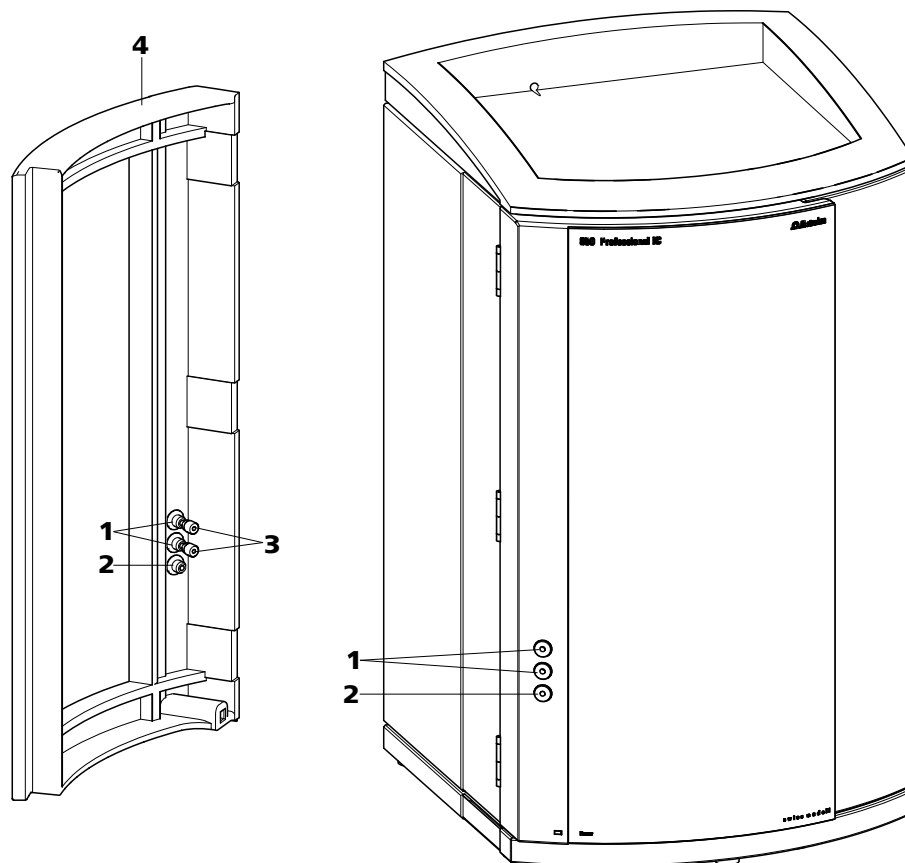

Figure 9 Capillary feed-throughs on the door

**1 Luer connectors**

For connecting a 6.2816.020 syringe. For manual sample feeding.

**3 PEEK pressure screws, short  
6.2744.070**

**2 Capillary feed-through**

**4 Door**

Do not feed capillaries through the Luer connectors (9-1). The capillaries are fastened with PEEK pressure screws (9-3) from inside to the Luer connector. From outside, liquid can be aspirated or injected with a syringe.

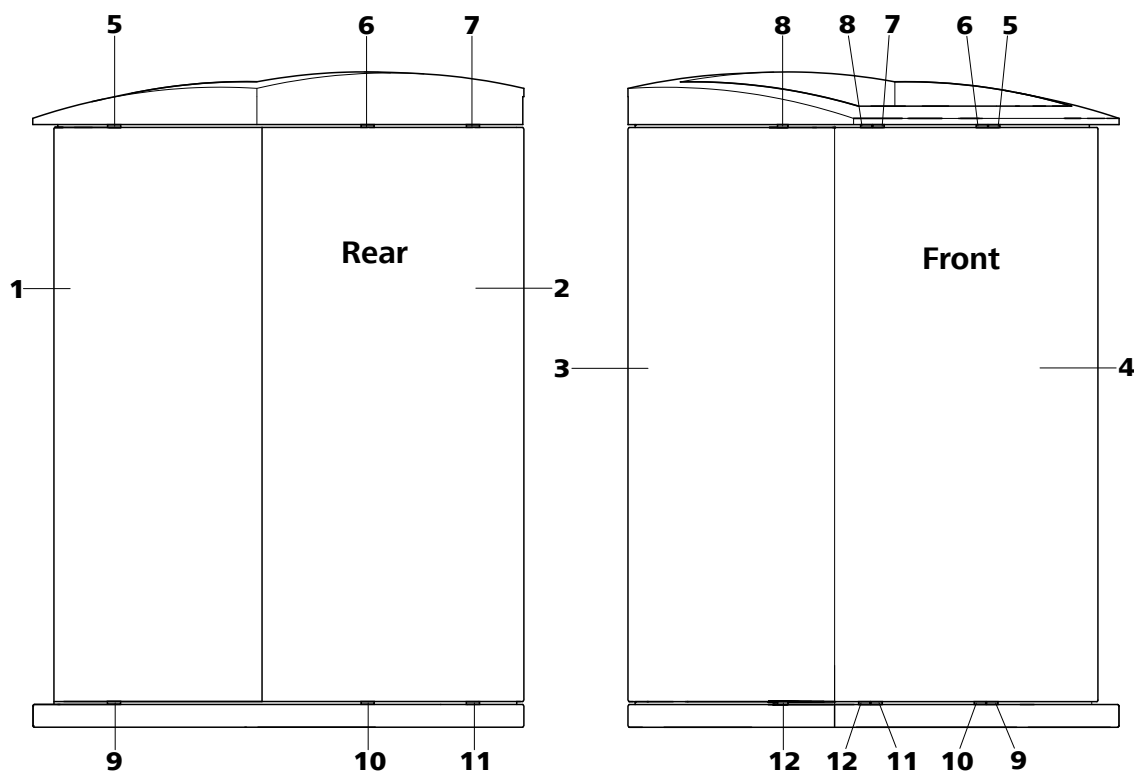

Figure 10 Capillary feed-throughs base tray/flask holder

<b>1 Side panel (right)</b> Right panel.	<b>2 Rear of the instrument</b>
<b>3 Side panel (left)</b> Left panel.	<b>4 Front of the instrument</b>
<b>5 Capillary feed-through</b> Upper. From front to right.	<b>6 Capillary feed-through</b> Upper. From front to back.
<b>7 Capillary feed-through</b> Upper. From front to back.	<b>8 Capillary feed-through</b> Upper. From front to left.
<b>9 Capillary feed-through</b> Lower. From front to right.	<b>10 Capillary feed-through</b> Lower. From front to back.
<b>11 Capillary feed-through</b> Lower. From front to back.	<b>12 Capillary feed-through</b> Lower. From front to left.



## 2.8 Eluent

### 2.8.1 Connecting the eluent bottle

The eluent is aspirated out of the eluent bottle via the eluent aspiration tubing (11-1).

The eluent aspiration tubing is connected to the eluent degasser (*see chapter 2.9, page 32*). The tubing must be threaded through a suitable capillary feed-through (*see chapter 2.7, page 25*) of the instrument before the other end can be equipped.

The following accessories are needed for equipping the eluent aspiration tubing:

- 6.1602.160 eluent bottle cap GL 45
- 6.2744.210 tubing adapter for aspiration filter
- 6.2821.090 aspiration filter

Proceed as follows for equipping the eluent aspiration tubing:

#### Assembling eluent aspiration tubing

- 1 Guide the free end of the eluent aspiration tubing (11-1) out of the instrument through a suitable capillary feed-through.
- 2 **Installing the eluent bottle cap (6.1602.160)**
  - Slide tubing nipple (11-2) and O-ring (11-3) onto the eluent aspiration tubing (11-1).
  - Push eluent aspiration tubing (11-1) through the bottle cap (11-4) and screw tight.

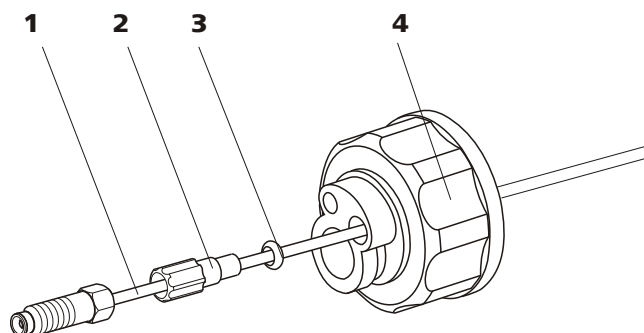

Figure 11 Installing the eluent bottle cap

**1 Eluent aspiration tubing (6.1834.080)**

**2 Tubing nipple**

From accessory set (6.1602.160).

**3 O-ring**

From accessory set (6.1602.160).

**4 Bottle cap**

From accessory set (6.1602.160).

### 3 Mounting the aspiration filter

- Insert the filter holder (12-**1**) into the aspiration filter (12-**2**) and screw it tightly.

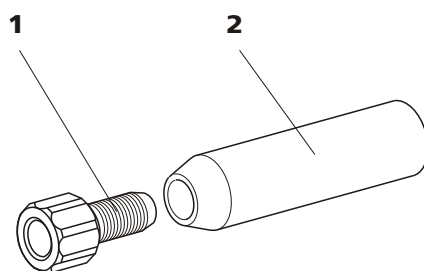

Figure 12 Mounting the aspiration filter

**1 Filter holder**

From accessory set (6.2744.210).

**2 Aspiration filter (6.2821.090)**

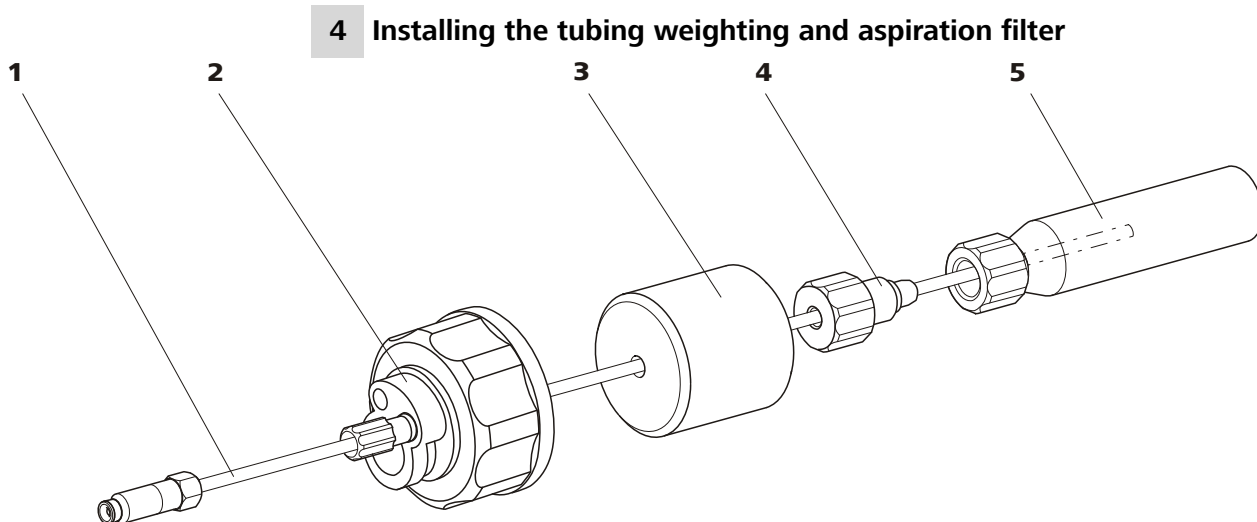

Figure 13 Installing the tubing weighting and aspiration filter

**1 Eluent aspiration tubing (6.1834.080)**

**2 Eluent bottle cap (6.1602.160)**

**3 Tubing weighting**  
From accessory set (6.2744.210).

**4 Clamping screw**  
From accessory set (6.2744.210).

**5 Aspiration filter (6.2821.090)**  
With filter holder from accessory set  
(6.2744.210).

- Slide the tubing weighting (13-3) onto the eluent aspiration tubing (13-1).
- Slide the clamping screw (13-4) onto the eluent aspiration tubing (13-1).
- Insert eluent aspiration tubing (13-1) into the aspiration filter (13-5). The end of the tubing should reach approximately to the center of the aspiration filter.
- Screw the clamping screw (13-4) to the filter holder (12-1).

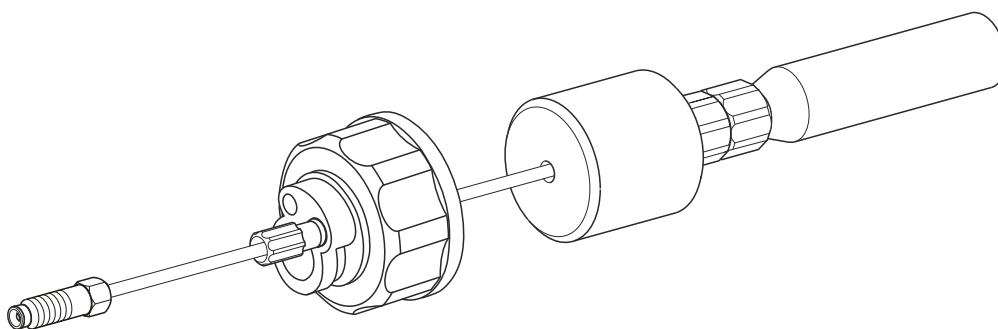

Figure 14 Eluent aspiration tubing fully equipped

#### 5 Mounting the eluent aspiration tubing to the eluent bottle

- Insert the eluent aspiration tubing into the eluent bottle (15-10).

- Tighten the fully equipped bottle cap to the eluent bottle (15-10). The aspiration filter (15-6) must rest on the base of the eluent bottle.
- Close the remaining small opening on the bottle cap with a threaded stopper (15-14) from the accessory set.

## 6 Mounting the adsorber tube



### NOTICE

If alkaline eluents or eluents with lower buffer capacity are used, the eluent bottle must be equipped with an adsorber tube filled with CO<sub>2</sub> adsorber (15-4).

- First, place a piece of cotton (15-3), then the CO<sub>2</sub> adsorber (15-4) in the large opening of the adsorber tube (15-2) and close with the plastic cover.
- Fasten the adsorber tube (15-2) on the bottle cap (15-11) using the SGJ clip (15-12).

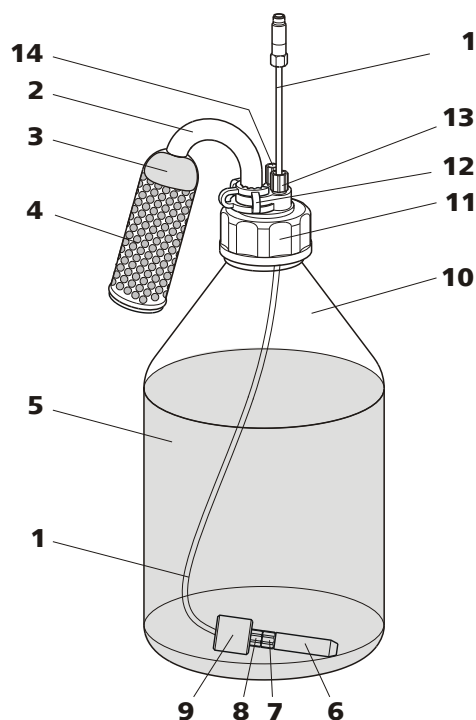

Figure 15 Eluent bottle – connected

**1 Eluent aspiration tubing (6.1834.080)**  
For aspirating the eluent. Pre-installed.

**2 Adsorber tube (6.1609.000)**



<b>3 Cotton</b>	<b>4 CO<sub>2</sub> adsorber</b> Adsorbs CO <sub>2</sub> from the air (e.g. Merck soda lime with indicator, no. 6839.1000).
<b>5 Eluent</b>	<b>6 Aspiration filter (6.2821.090)</b>
<b>7 Filter holder</b> From accessory set (6.2744.210).	<b>8 Clamping screw</b> From accessory set (6.2744.210).
<b>9 Tubing weighting</b> From accessory set (6.2744.210).	<b>10 Eluent bottle (6.1608.070)</b>
<b>11 Bottle cap (6.1602.160)</b>	<b>12 SGJ clip (6.2023.020)</b>
<b>13 Tubing nipple</b>	<b>14 Threaded stopper</b>

## 2.9 Eluent degasser

Gas bubbles in the eluent lead to an unstable baseline, as high pressure pumps can transport liquids, but not gases. This is why the eluent must be degassed before it reaches the high-pressure pump.

The eluent degasser removes gas bubbles and dissolved gases from the eluent. For degassing, the eluent flows into a vacuum chamber through a special fluoropolymer capillary.



### NOTICE

The eluent degasser is already installed in the newly delivered instrument. The following installation instructions must only be followed, if the connections to the degasser had to be disconnected for maintenance.

### Connecting the eluent degasser

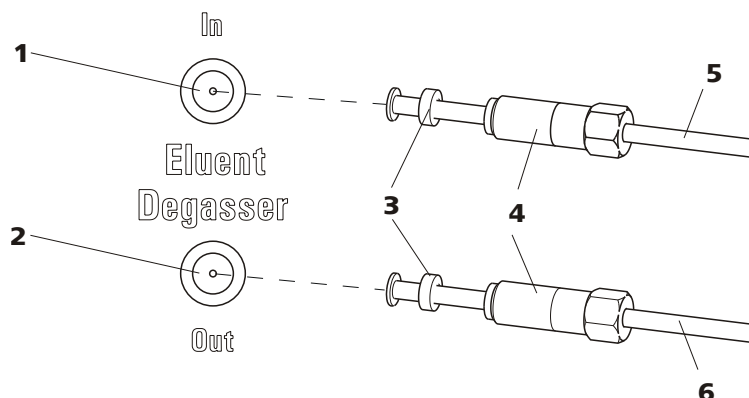

Figure 16 Eluent degasser

<b>1 Eluent degasser input</b>	<b>2 Eluent degasser output</b>
<b>3 Tubing flare</b> With tubing nipple.	<b>4 Clamping screw</b>
<b>5 Eluent aspiration tubing (6.1834.080)</b> For aspirating the eluent. The clamping screw (16-4) is firmly mounted.	<b>6 Connection tubing (6.1834.090)</b> Connection from the eluent degasser to the high-pressure pump (see chapter 2.10, page 34). The clamping screw (16-4) is firmly mounted.

1



#### CAUTION

The clamping screws (16-4) must be tightened carefully. Use the wrench (6.2621.050) to do this.

- Insert the eluent aspiration tubing (16-5) into the eluent degasser input (16-1).

■ Carefully tighten the clamping screw (16-4).
- Insert connection tubing (16-6) (the end with the longer clamping screw (16-4)) into the eluent degasser output (16-2).

■ Carefully tighten the clamping screw (16-4).

■ Connect the other end of the connection capillary (16-6) (with the shorter clamping screw) to the high-pressure pump (17-9) (see "Connecting inlet to the high pressure pump", page 35).



## 2.10 High pressure pump

The intelligent and low pulsation high pressure pump pumps the eluent through the system. It is equipped with a chip on which its technical specifications and "life history" (operating hours, service data, ...) are saved.

The purge valve is used for deaerating (*see chapter 2.10.2, page 36*) the high pressure pump.

### 2.10.1 Capillary connections high pressure pump/purge valve



#### NOTICE

All of the capillary connections of the high pressure pump and the purge valve are already installed in the newly delivered instrument.

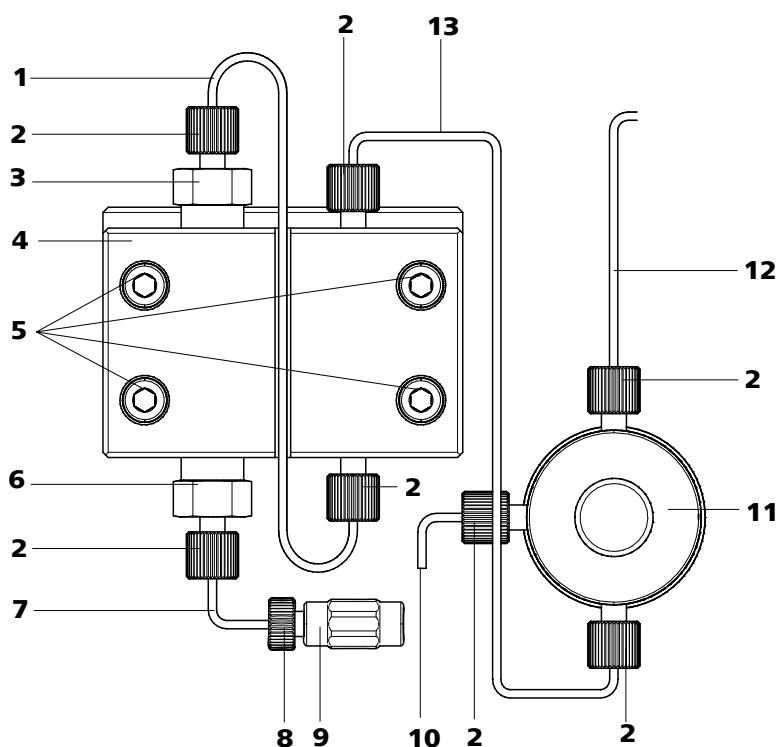

Figure 17 Capillary connections high pressure pump/purge valve

<p><b>1 Connection capillary</b> PEEK capillary, connects main piston and auxiliary piston.</p>	<p><b>2 PEEK pressure screw, short (6.2744.070)</b></p>
<p><b>3 Outlet valve holder</b></p>	<p><b>4 Pump head (6.2824.110)</b></p>

**5 Fastening screws**

For fastening the pump head.

**7 Pump head inlet capillary**

PEEK capillary at the input of the pump head.

**9 Coupling**

For the connection of the eluent path at the input of the high pressure pump. Can be ordered together with the pressure screw (17-8) under the number (6.2744.230).

**11 Purge valve**

For deaerating the high pressure pump. With rotary knob in the center and pressure sensor.

**13 Connection capillary**

Connects the output of the pump head with the purge valve.

**6 Inlet valve holder****8 Pressure screw**

For connecting a PEEK capillary to the coupling (17-9).

**10 Deaerating capillary**

For aspirating the eluent when deaerating the high pressure pump (see chapter 2.10.2, page 36).

**12 Connection capillary**

For connecting the inline filter (see chapter 2.11, page 38).

**NOTICE**

The eluent aspiration capillary is already installed in the newly delivered instrument. The following installation instructions need **not** be carried out at the time of initial installation.

**Connecting inlet to the high pressure pump**

Figure 18 High pressure pump – Connect inlet

**1 Pressure screw**

For connecting the coupling (18-2) to the pump head inlet capillary (17-7). Can be ordered together with the coupling under the number (6.2744.230).

**2 Coupling (6.2744.230)**

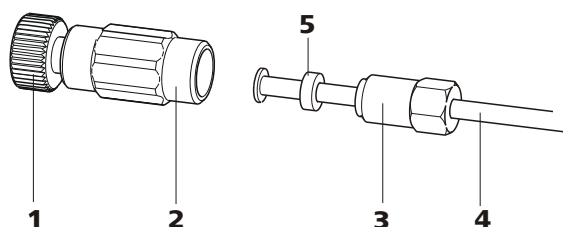
For connecting the eluent connection capillary (18-4) to the input of the high pressure pump.



**3 Clamping screw**

**4 Eluent aspiration tubing**

Eluent aspiration tubing (6.1834.080) or (6.1834.090).

**5 Backup ring**

**1 Connecting coupling**

Fasten the coupling (18-2) with a pressure screw (18-1) on the pump head inlet capillary (17-7).

**2 Connecting eluent aspiration tubing**



**CAUTION**

The clamping screws must be tightened carefully. To tighten, grip the coupling (18-2) with the key (6.2739.000) and grip the clamping screw (18-3) with the wrench (6.2621.050).

- Plug the eluent aspiration tubing (18-4) into the coupling (18-2).
- Tighten the clamping screw (18-3).

**2.10.2 Deaerating the high pressure pump**

The high pressure pump will only operate perfectly if the pump head contains no more air bubbles. Therefore it must be deaerated during initial start-up and after every change of eluent.



**CAUTION**

The high pressure pump must **not** be deaerated before the initial start-up .

Deaerate the high pressure pump as follows (see figure 19, page 37):

**Deaerate the high pressure pump**

The instrument must be connected to the PC and switched on to deaerate the high pressure pump.

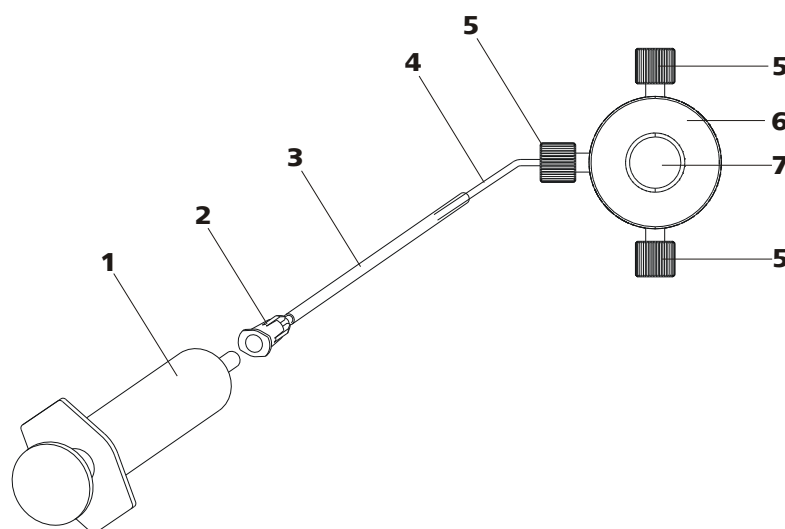

Figure 19 Deaerate the high pressure pump

<b>1</b>	<b>Syringe 10 mL (6.2816.020)</b> For aspirating the eluent.	<b>2</b>	<b>Luer connector</b> Part of the purging needle (6.2816.040)
<b>3</b>	<b>Purging needle (6.2816.040)</b>	<b>4</b>	<b>Deaerating capillary</b>
<b>5</b>	<b>PEEK pressure screws, short (6.2744.070)</b>	<b>6</b>	<b>Purge valve</b>
<b>7</b>	<b>Purge valve rotary knob</b>		

### 1 Connecting the purging needle

- Push the end of the purging needle (19-3) over the end of the deaerating capillary (19-4) on the purge valve.

### 2 Connecting the syringe

- Insert syringe (19-1) in the Luer connector (19-2) of the purging needle (see figure 19, page 37).

### 3 Opening purge valve

- Open the rotary knob (19-7) by approx.  $\frac{1}{2}$  rotation counterclockwise.

### 4 Setting the flow rate

- Start MagIC Net™ (if not yet started).
- Ensure that the eluent aspiration tubing is immersed sufficiently in the eluent.
- Let the high pressure pump run.



### 5 Aspirating eluent

- Aspirate with the syringe (19-1) until bubble-free eluent flows into the syringe.

### 6 Completing deaerating

- Switch off high pressure pump.
- Close rotary knob (19-7).
- Remove syringe (19-1) from the Luer connector (19-2).
- Pull the purging needle (19-3) out of the deaerating capillary (19-4).

## 2.11 Inline filter

Between the purge valve and the pulsation absorber the inline filter (6.2821.120) is installed as protection against particles.

Inline filters protect the separation column securely against possible contamination from the eluent. Inline filters can however also just as well be used for the purpose of protecting the suppressor against contaminations in the regeneration or rinsing solutions. The filter platelets with a pore size of 2 µm can be replaced quickly and easily. They remove particles like e. g. bacteria and algae from the solutions.



#### NOTICE

The inline filter is already installed in the newly delivered instrument. The following installation instructions need **not** be carried out at the time of initial installation.

#### Installing the inline filter



#### CAUTION

Observe the flow direction marked on the filter housing for the connection of the inline filter.

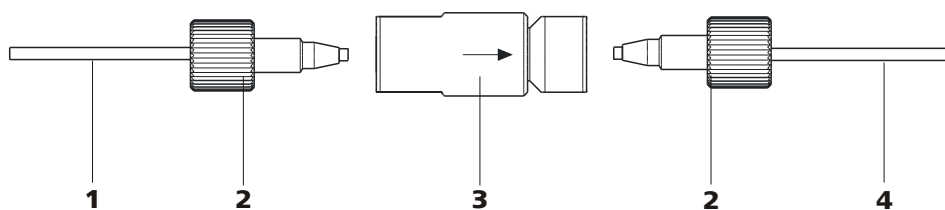

Figure 20 Connecting the inline filter

**1 Connection capillary**

Connects the purge valve with the inline filter

**3 Inline filter (6.2821.120)**

Protects against particles.

**2 PEEK pressure screws, short (6.2744.070)**

**4 Connection capillary**

Connects the inline filter with the pulsation absorber.

- 1** Screw on the connection capillary running from the purge valve to the input side of the inline filter using a pressure screw (6.2744.070).
- 2** Screw on the connection capillary running to the pulsation absorber to the output side of the inline filter using a pressure screw (6.2744.070).

## 2.12 Pulsation absorber



### NOTICE

The pulsation absorber is already installed in the newly delivered instrument.



### CAUTION

The pulsation absorber is maintenance-free and may not be opened.

The pulsation absorber protects the separation column from damage caused by pressure fluctuations when switching the injection valve, and reduces interfering pulsations during highly sensitive measurements. In order to ensure these functionalities, it must be connected between the high pressure pump (see chapter 2.10, page 34) and injection valve (see chapter 2.15, page 47).

The pulsation absorber can be operated in both directions.

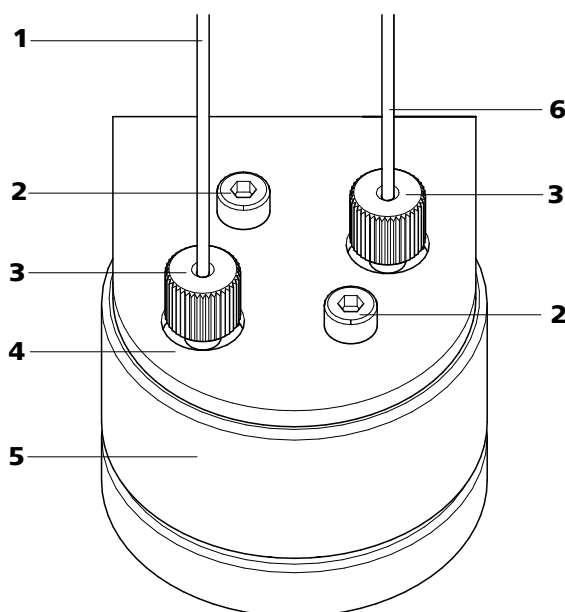

Figure 21 Pulsation absorber – Connection

<b>1 Connection capillary</b> Connection to the inline filter.	<b>2 Fastening screws</b>
<b>3 PEEK pressure screws, short (6.2744.070)</b>	<b>4 Holder for pulsation absorber</b>
<b>5 Pulsation absorber (6.2620.150)</b>	<b>6 Connection capillary</b> Connection to the injection valve.

## 2.13 Sample degasser

The sample degasser removes gas bubbles and dissolved gases from the sample. For degassing, the sample flows into a vacuum chamber through a special fluoropolymer capillary.

Gas bubbles in the sample lead to poor reproducibility, as the amount of sample in the sample loop would not always be the same. This is why samples (containing gas) should be degassed prior to injection. The sample is drawn in through a degassing chamber prior to injection and any gas bubbles are automatically removed.



### NOTICE

The rinsing time increases by at least 2 minutes when the sample degasser is used.

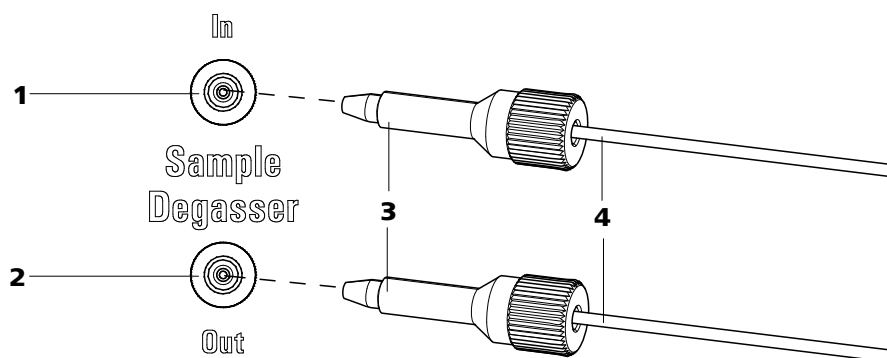

Figure 22 Sample degasser

**1** Sample degasser input

**2** Sample degasser output

**3** PEEK pressure screw, long  
(6.2744.090)

**4** Connection capillaries (6.1803.040)

### Connecting the sample degasser

- 1** Remove and keep the threaded stoppers (6.2744.220) from the inlet and outlet of the sample degasser.
- 2** Connect the end of the sample aspiration capillary (6.1803.040) connected to the injection valve to the output of the sample degasser (22-**2**), using a long PEEK pressure screw (22-**3**).
- 3** Connect the connection capillary (6.1803.040) to the input of the sample degasser (22-**1**), using a long PEEK pressure screw (22-**3**).
- 4** Guide the other end of the connection capillary out of the instrument through a capillary feed-through and connect it with the Sample Processor, if applicable.



### CAUTION

If the sample degasser is not used, the input and output **must** be sealed with the threaded stoppers (6.2744.220).



## 2.14 Peristaltic pump

### 2.14.1 Principle of the peristaltic pump

The Peristaltic pump is used for pumping sample and auxiliary solutions. It can rotate in both directions.

The peristaltic pump pumps liquids according to the principle of displacement. The pump tubing is clamped between the rollers (23-**3**) and the tubing cartridge (23-**5**). During operation, the peristaltic pump drive rotates the roller hub (23-**2**), so that the rollers (23-**3**) push the liquid forward in the pump tubing.

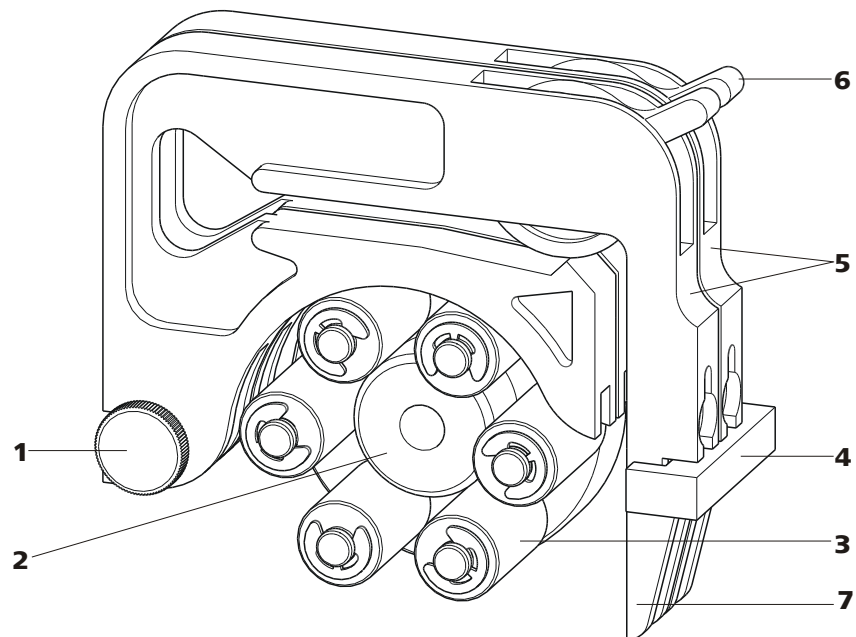

Figure 23 Peristaltic pump

<b>1</b>	<b>Knurled screw in the mounting pin</b>	<b>2</b>	<b>Roller hub</b>
<b>3</b>	<b>Rollers</b>	<b>4</b>	<b>Cartridge holder</b>
<b>5</b>	<b>Tubing cartridges 6.2755.000</b>	<b>6</b>	<b>Contact pressure lever</b>
<b>7</b>	<b>Snap-action lever</b>		

### 2.14.2 Installing the peristaltic pump

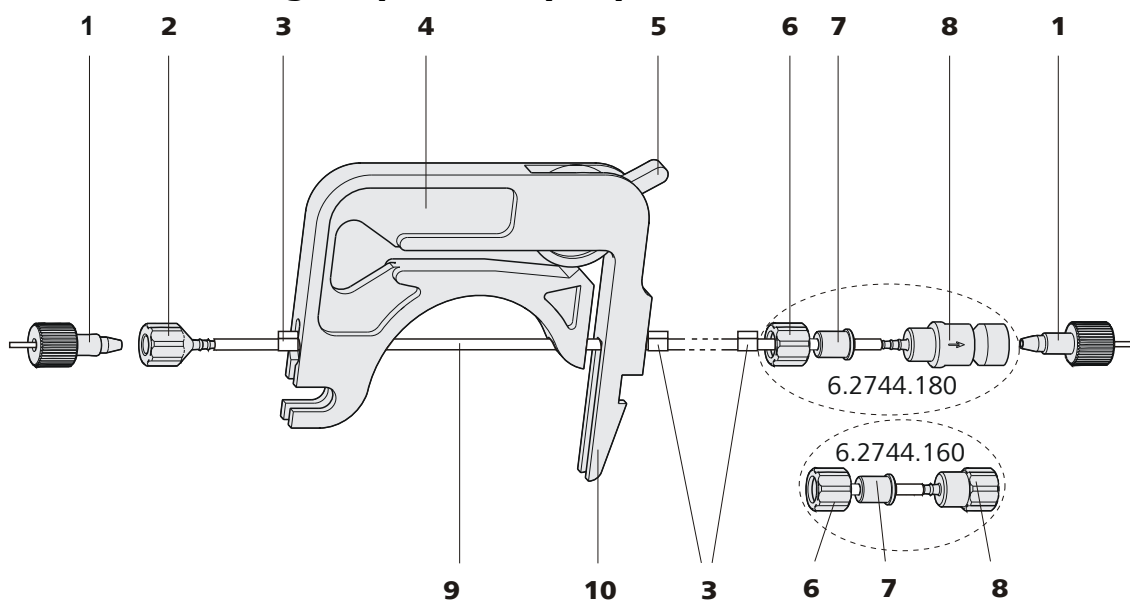

Figure 24 Installing the pump tubing

<b>1</b> PEEK pressure screws, short (6.2744.070)	<b>2</b> Tubing olive (6.2744.034)
<b>3</b> Stopper The colors of the stopper indicate the inner diameter of the pump tubing.	<b>4</b> Tubing cartridge (6.2755.000)
<b>5</b> Contact pressure lever	<b>6</b> Union nut
<b>7</b> Adapter	<b>8</b> Tubing olive Either with filter holder (6.2744.180) or without filter holder (6.2744.160).
<b>9</b> Pump tubing (6.1826.xx0)	<b>10</b> Snap-action lever

Mount the pump tubing as follows:

#### 1 Removing the tubing cartridge

Release the tubing cartridge from the cartridge holder by pressing the snap-action lever and unhooking from the mounting pins (23-**1**).

#### 2 Connecting the aspiration side

Place a 6.2744.034 tubing olive (24-**2**) on the aspiration side of the pump tubing.



### 3 Connecting the pressure side



#### NOTICE

Depending on the use of the peristaltic pump, on the pressure side you can either connect:

- **Case A:** a 6.2744.180 pump tubing connection **with filter** (see figure 25, page 44) or
- **Case B:** a 6.2744.160 pump tubing connection **without filter** (see figure 26, page 45).

For pumping the auxiliary solutions to the MSM or to the SPM, a 6.2744.180 pump tubing connection **with filter must** be used.

**Case A:** 6.2744.180 pump tubing connection with filter:

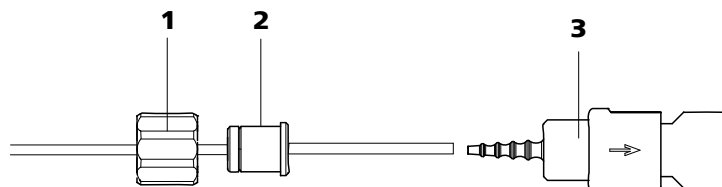

Figure 25 Install pump tubing connection with filter

**1 Union nut**

**2 Adapter**

**3 Tubing olive with filter holder**

- Slide union nut (25-**1**) onto the pump tubing.
- Select a suitable adapter (25-**2**) and slide it onto the pump tubing. The type of adapter depends on the pump tubing (see table 1, page 45).
- Place the tubing olive with filter holder (25-**3**) onto the pump tubing.
- Screw the union nut (25-**1**) onto the tubing olive (25-**3**).

or

**Case B:** 6.2744.160 pump tubing connection without filter:

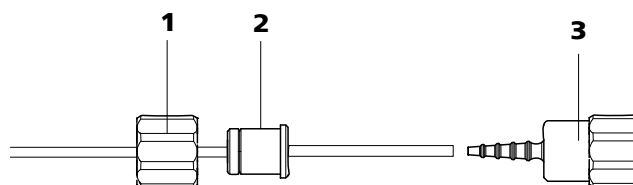

Figure 26 Install pump tubing connection without filter

**1 Union nut**

**2 Adapter**

**3 Tubing olive**

- Slide union nut (26-**1**) onto the pump tubing.
- Select a suitable adapter (26-**2**) and slide it onto the pump tubing. The type of adapter depends on the pump tubing (see table 1, page 45).
- Place the tubing olive (26-**3**) onto the pump tubing.
- Screw the union nut (26-**1**) onto the tubing olive (26-**3**).

#### 4 Inserting the pump tubing

- Press the contact pressure lever all the way down.
- Place the pump tubing in the tubing cartridge. The stoppers (24-**3**) must snap into the corresponding holders of the tubing cartridge.





#### 5 Inserting the tubing cartridge

- Hang the tubing cartridge in the mounting pin and press in the cartridge holder until the snap-action lever snaps in.





#### 6 Connecting the capillaries

- Screw the respective capillaries tightly to the two tubing olives with PEEK pressure screws (24-**1**).

Table 1 Pump tubings and suitable adapters

Pump tubing	Adapter
6.1826.020 (blue/blue)	
6.1826.310 (orange/green)	
6.1826.320 (orange/yellow)	
6.1826.330 (orange/white)	



Pump tubing	Adapter
6.1826.340 (black/black)	
6.1826.360 (white/white)	
6.1826.380 (gray/gray)	
6.1826.390 (yellow/yellow)	

### Set flow rate

The contact pressure of the tubing cartridge must be adjusted in order to regulate the flow rate. Proceed as follows:

#### Set the contact pressure

- 1
  - Fully loosen the contact pressure lever (24-5), i.e. press it all the way down.
  - Switch on the peristaltic pump.
  - Raise the contact pressure lever one step at a time until liquid flows.
  - When liquid starts flowing, raise the contact pressure lever by an additional 2 ratchet increments.

The contact pressure is now set optimally.

The delivery rate depends not only on the correct contact pressure but also on the interior diameter of the pump tubing and the rotational speed of the drive.



#### NOTICE

Pump tubings are consumable material. The service life of the pump tubings depends on the contact pressure amongst other factors.

## 2.15 Injection valve

The injection valve connects the eluent and sample path. Through rapid and precise valve switchover a precise amount of sample solution defined by the size of the sample loop is injected and rinsed with eluent onto the separation column.

### 2.15.1 Connecting the injection valve

The injection valve has six connectors: two for the sample path (connectors 1 and 2), two for the eluent path (connectors 4 and 5) and two for the sample loop (connectors 3 and 6).



#### NOTICE

The capillaries of the eluent path and the sample path and the sample loop are already installed in the newly delivered instrument.

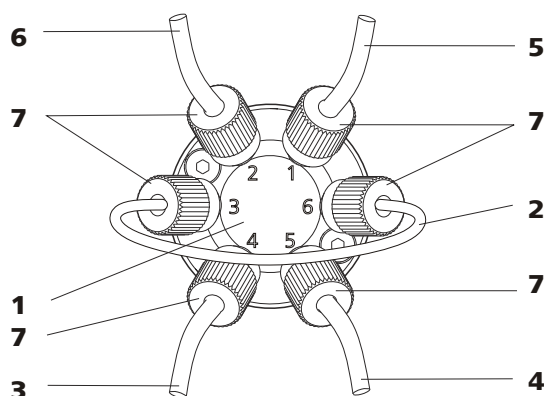

Figure 27 Injection valve – connected

#### 1 Injection valve

#### 2 Sample loop

Connected to connectors 3 and 6.

#### 3 Connection capillary

Connected to connector 4. Carries eluent to the injection valve.

#### 4 Connection capillary (column inlet capillary)

Connected to connector 5. Carries eluent to the separation column.

#### 5 Connection capillary

Connected to connector 1. Carries sample to the injection valve.

#### 6 Connection capillary

Connected to connector 2. Carries sample to the waste container.

#### 7 PEEK pressure screw 6.2744.010



<b>1 Eluent input</b> Capillary coming from the high pressure pump.	<b>2 Eluent output</b> Capillary to the column.
<b>3 Sample input</b> Sample aspirating capillary.	<b>4 Sample output</b> Capillary to waste container.
<b>5 Sample loop</b>	

**Position A**

In the position **FILL**, the sample solution flows through the sample loop to the waste container. The eluent flows directly to the separation column at the same time.

**Position B**

In the position **INJECT**, the eluent flows through the sample loop to the separation column. If sample solution is to be found in the sample loop at the time of the valve switchover, then this will be conveyed along with the eluent, thus making its way to the separation column. The flow in the sample path is either stopped or the sample flows directly to the waste container.

**2.15.3 Selecting the sample loop**

The amount of sample solution injected depends on the volume of the sample loop. The choice is made on the basis of the application. The following sample loops are normally used:

Cation determination	10 µL
Anion determination with suppression	20 µL
Anion determination without suppression	100 µL

**2.16 Column thermostat**

The column thermostat controls the temperature of the column and eluent channel and thus ensures stable measuring conditions. It provides space for 2 separation columns.

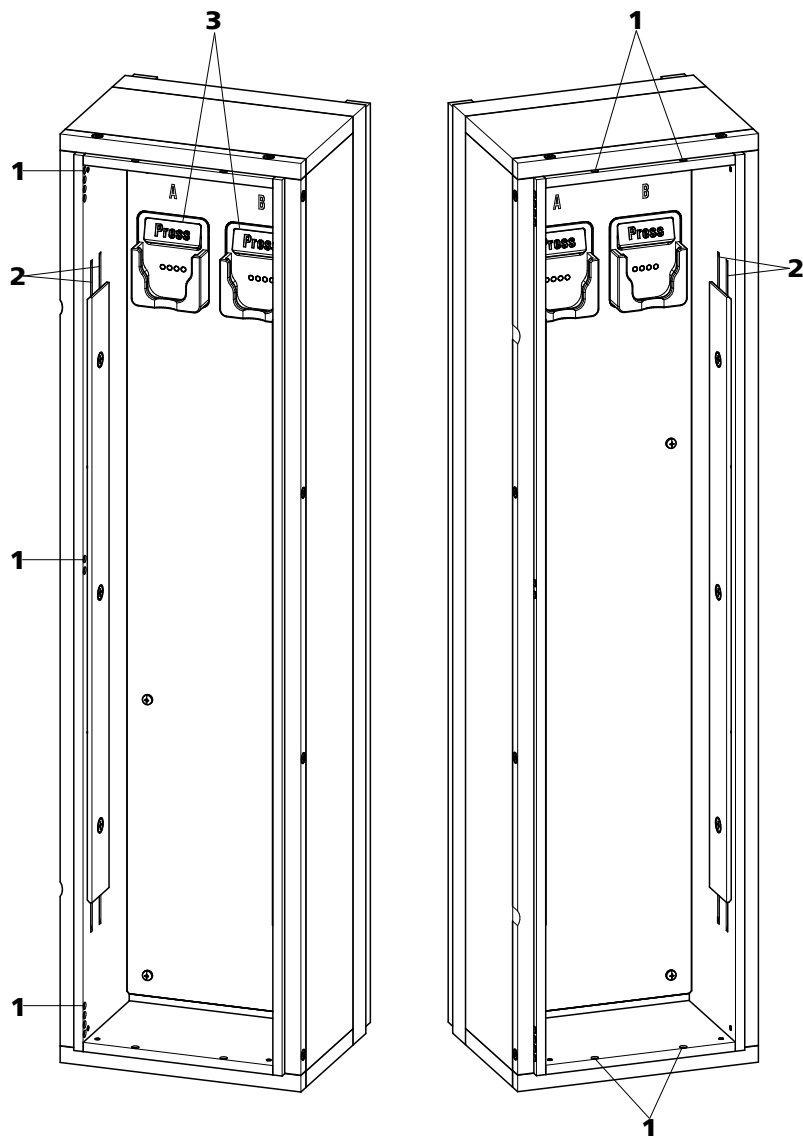

Figure 29 Column thermostat

**1 Capillary feed-throughs**

For guiding the capillaries in and out.

**2 Capillary recesses**

For controlling the temperature of the eluent.

Preheating capillary already pre-installed.

**3 Column holder**

For fastening the columns.

With column recognition.

The column thermostat contains two column holders (29-**3**) equipped with chip recognition. The separation columns can be clicked into the column holder with the chip.



### NOTICE

The column input capillary is already threaded into the capillary recesses of the column thermostat at the time the instrument is first delivered. The following installation instructions need **not** be carried out at the time of initial installation.

### Threading capillaries

- 1 Introduce column input capillary into the column thermostat via a suitable capillary feed-through (29-1).
- 2 Slide the column input capillary from below into the outer of the two capillary recesses (29-2). Slide it through under the holder plate until it emerges again at the top.
- 3 Carefully bend the column input capillary downward and slide from from above to below through the inner capillary recess until it emerges at the lower edge of the holder plate.

4



### NOTICE

The columns (guard column and separation column) may only be installed after the initial start-up .

- **Before initial start-up:**  
Fasten the 6.2744.040 coupling with a 6.2744.010 pressure screw to the end of the column input capillary.
- **After initial start-up:**  
Fasten the guard column (if used) or the separation column with a 6.2744.010 pressure screw to the end of the column input capillary.



## 2.17 Conductivity detector

The conductivity detector continuously measures the conductivity of the liquid passing through and indicates these signals in digital form (DSP – Digital Signal Processing). The conductivity detector exhibits outstanding thermal stability and thus guarantees reproducible measuring conditions.

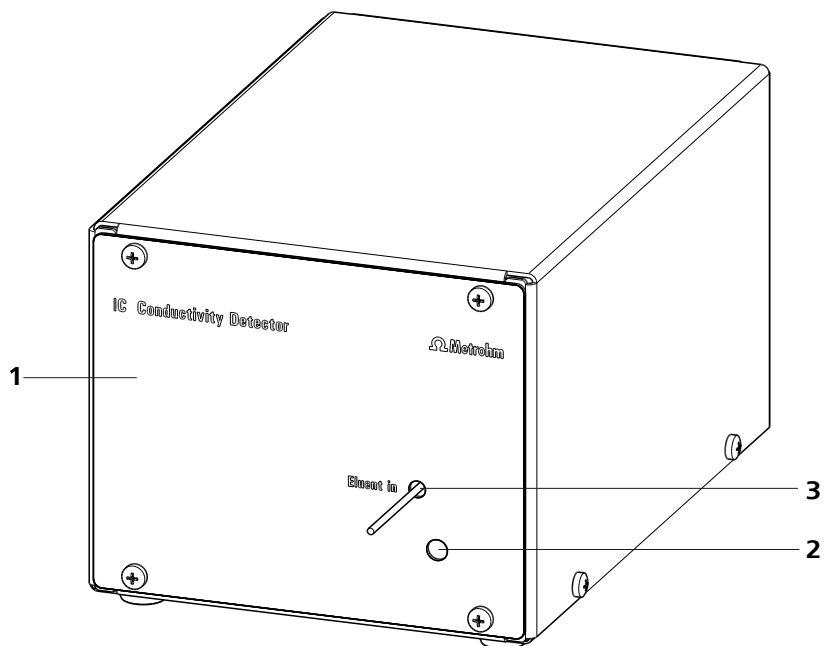

Figure 30 Conductivity detector front

**1 IC detector 1.850.9010**

**2 Opening for temperature sensor**

**3 Detector input capillary**  
Permanently installed.

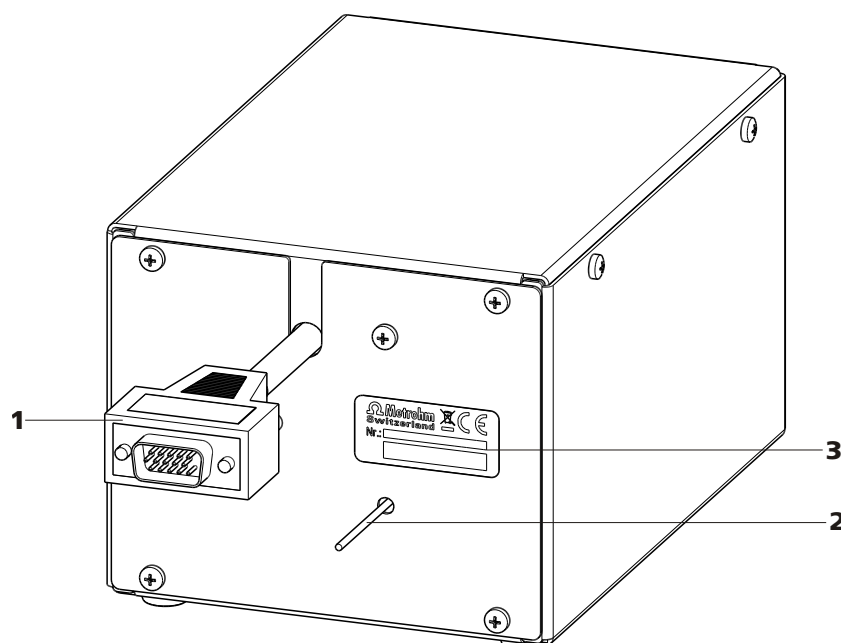

Figure 31 Conductivity detector rear

**1 Detector cable**  
With mounted plug.

**2 Detector output capillary**  
Permanently installed.

**3 Type plate**  
With serial number.



#### NOTICE

In order to prevent unnecessary peak widening after separation, the connection between the outlet of the separation column and the inlet in the detector should be kept as short as possible.

#### Connect the detector input capillary to the separation column

##### 1 Connecting detector input

- Fasten the detector input capillary (32-1) on the output of the column (32-3) using a 6.2744.070 pressure screw (32-2).

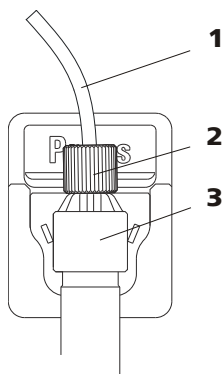

Figure 32 Connection detector – separation column

- |                                   |  |
|-----------------------------------|--|
| <b>1</b> Detector input capillary | <b>2</b> PEEK pressure screw, short 6.2744.070 |
| <b>3</b> Separation column        |  |

## 2.18 Connecting the instrument to a computer



### NOTICE

If the instrument is connected to the computer, then it must be switched off.

#### Accessories

For this step, you need the following accessories:

- USB connecting cable (6.2151.020)

#### Connecting the USB cable

- 1** Insert the USB cable into the computer connection socket on the rear of the instrument labeled *PC*.
- 2** Insert the other end into a USB port on the computer.

## 2.19 Connecting the instrument to the power grid



### WARNING

#### Electric shock from electrical potential

Risk of injury by touching live components or through moisture on live parts.

- Never open the housing of the instrument while the power cord is still connected.
- Protect live parts (e.g. power supply unit, power cord, connection sockets) against moisture.
- Unplug the power plug immediately if you suspect that moisture has gotten inside the instrument.
- Only personnel who have been issued Metrohm qualifications may perform service and repair work on electrical and electronic parts.

### Connecting the power cord

#### Accessories

Power cord with the following specifications:

- Length: max. 2 m
- Number of cores: 3, with protective conductor
- Instrument plug: IEC 60320 type C13
- Conductor cross-section 3x min. 0.75 mm<sup>2</sup> / 18 AWG
- Power plug:
  - according to customer requirement (6.2122.XX0)
  - min. 10 A



### NOTICE

Do not use a not permitted power cord!

#### 1 Plugging in the power cord

- Plug the power cord into the instrument's power socket.
- Connect the power cord to the power grid.



## 2.20 Guard column

The use of guard columns serves for protecting the separation columns and increasing their service life considerably. The guard columns available from Metrohm represent either actual guard columns or are so-called guard column cartridges which are used together with a cartridge holder. The installation of a guard column cartridge in the associated holder is described in the leaflet of the guard columns.



### NOTICE

---

Information regarding which guard column is suitable for your separation column can be found in the **Metrohm IC Column Program** (which is available from your Metrohm agent), the leaflet provided along with your separation column, the product information on the separation column at <http://www.metrohm.com> (product area Ion Chromatography), or obtained directly from your agent.



### CAUTION

---

New guard columns are filled with solution and are sealed on both sides with stoppers or caps, respectively. Before using the guard column, you need to ensure that this solution is miscible with the eluents used (observe manufacturer's data).



### NOTICE

---

The guard column may only be installed after the **initial start-up** (see *chapter 3.1, page 60*) of the instrument. Until then, use the coupling (6.2744.040) instead of the guard and separation column.



### NOTICE

---

Metrohm recommends, always to work with guard columns. These protect the separation column and can be exchanged regularly.

## Connecting and rinsing the guard column

### 1 Connecting the guard column



#### CAUTION

When inserting the guard column, always ensure that it is inserted correctly corresponding to the flow direction (if indicated).

- Remove sealing caps and/or stoppers from the guard column.
- Fasten the input of the guard column to the column inlet capillary using a short PEEK pressure screw (6.2744.070).
- In case the guard column is mounted on the separation column with a connecting capillary, connect the included connection capillary, which is included with the guard column, to the output of the guard column using the PEEK pressure screw, which is also included.

### 2 Rinsing the guard column

- Place beaker under the outlet capillary of the guard column.
- Set the flow rate of the high pressure pump according to the data given in the leaflet of the separation column.
- Start the high pressure pump and rinse the guard column approx. 5 minutes with eluent.
- Switch off the high pressure pump again.

## 2.21 Separation column

The intelligent separation column (iColumn) is the heart of the ion chromatographic analysis. It separates the different components corresponding to their interactions with the column. Metrohm separation columns are equipped with a chip on which their technical specifications and their history (first use / setting up, operating hours, injections, ...) are saved.



#### NOTICE

Information regarding which separation column is suitable for your application can be found in the **Metrohm IC Column Program**, the product information for your separation column at <http://www.metrohm.com> in the product area ion chromatography, or obtained directly from your agent.



### CAUTION

New separation columns are filled with solution and are sealed on both sides with stoppers. Before using the column, you need to ensure that this solution is miscible with the eluents used (observe manufacturer's data).

You can find the separation columns and guard columns currently available from Metrohm in the Metrohm IC Column Program, or in the Internet at <http://www.metrohm.com> in the product area Ion Chromatography. A test chromatogram and an leaflet are provided along with each column. You can request detailed information on special IC applications in the corresponding "**Application Bulletins**" or "**Application Notes**", available in the Internet at <http://www.metrohm.com> in the Applications area or via the Metrohm agent responsible free of charge.



### NOTICE

The separation column may only be installed after the **initial start-up** (see chapter 3.1, page 60) of the instrument. Until then, use the coupling (6.2744.040) instead of the guard and separation column.

## Connecting and rinsing the separation column

### 1 Connect the separation column



### CAUTION

When inserting the columns, always ensure that these are correctly inserted corresponding to the flow direction indicated.

- Remove stoppers from the separation column.
- Attach the guard column to the input of the separation column.  
OR  
Connect the input of the separation column to the outlet capillary of the guard column, using the PEEK pressure screw (6.2744.070) included.  
OR  
If no guard column is used (not recommended), connect the column input capillary to the input of the separation column, using a PEEK pressure screw (6.2744.070).

## 2 Rinsing the separation column

- Place beaker under the outlet end of the separation column.
- Set the flow rate of the high pressure pump according to the data given in the leaflet of the separation column.
- Start the high pressure pump and rinse the separation column approx. 10 minutes with eluent.
- Switch off the high pressure pump again.

## 3 Mounting the separation column

- Fasten the column output capillary to the output of the separation column using a PEEK pressure screw (6.2744.070).
- Hang separation column with chip into the column holder.



### NOTICE

---

The iColumns are equipped with a chip on which their operating data is saved. The chip has to be hooked into the chip holder provided for this so that the column recognition can function.



The instrument is now ready for the installation of the columns.

## 3.2 Conditioning

After the installation and after switching on the instrument, the system must be conditioned with eluent until a stable baseline is reached.



### NOTICE

After a change of eluent (*see chapter 4.4.2.3, page 66*), the conditioning time can lengthen considerably.

### Conditioning the system

#### 1 Preparing the software



### CAUTION

Ensure that the flow set is not higher than the flow permissible for the corresponding column (see column leaflet and chip data set).

- Start the PC program **MagIC Net™**.
- Open the **Equilibration** tab in **MagIC Net™**.
- Select (or create) a suitable method.

#### 2 Preparing the instrument

- Ensure that the column is correctly mounted according to the flow direction indicated on the label (arrow must point in the direction of flow).
- Ensure that the eluent aspiration tubing is immersed in the eluent and that there is enough eluent in the eluent bottle.

#### 3 Checking leak-tightness

- In **MagIC Net™**, start the equilibration.
- Check all capillaries and their connections from the high pressure pump to the detector block for signs of liquid escaping. If eluent escapes anywhere, tighten the corresponding pressure screw or loosen the connection, check the end of the capillary, shorten it with a capillary cutter if necessary, and restore the connection.



**4 Conditioning the system**

Rinse the system with eluent until the required stability of the baseline is attained (normally 30 minutes).

The instrument is now ready for measuring samples.

## 4 Operation and maintenance

### 4.1 General notes

#### 4.1.1 Care



#### WARNING

The instrument housing must not be opened by untrained personnel.

The instrument requires appropriate care. Excess contamination of the instrument may result in functional disruptions and a reduction in the service life of the sturdy mechanics and electronics.



#### CAUTION

Although this is prevented to a great extent by design measures, the mains plug should be unplugged immediately if aggressive media has penetrated the inside of the instrument, so as to avoid serious damage to the instrument electronics. In such cases, the Metrohm Service must be informed.

On the rear of the instrument, the drainage tubings must be mounted and the leak sensor must be plugged in and activated as protection against escaping liquids.

Spillages of chemicals and solvents should be cleaned up immediately. In particular, the plug connections on the rear panel of the instrument (especially the mains plug) should be protected from contamination.

#### 4.1.2 Maintenance by Metrohm Service

Maintenance of the instrument is best carried out as part of an annual service, which is performed by specialist personnel from Metrohm. If working frequently with caustic and corrosive chemicals, a shorter maintenance interval is recommended. The Metrohm service department offers every form of technical advice for maintenance and service of all Metrohm instruments.



## 4.3 Door



### CAUTION

The door is made of PMMA (polymethylmetacrylate). It must never be cleaned with abrasive media or solvents.



### CAUTION

Never use the door as a handle.

## 4.4 Eluent

### 4.4.1 Production

Chemicals used for manufacturing eluents must have a purity grade of at least "p.a.". Only ultrapure water (resistance > 18.2 MΩ\*cm) may be used for dilution (this generally applies for reagents which are used in ion chromatography).

Newly manufactured eluents always have to be microfiltered (0.45 µm filter).

The composition of the eluent plays a critical role in chromatographic analysis:

<b>Concentration</b>	An increase in the concentration generally leads to shorter retention times and faster separation, but also to a higher background conductivity signal.
<b>pH</b>	pH changes lead to shifts in dissociation equilibria and thus to changes in retention times.
<b>Organic solvents</b>	Adding an organic solvent (e.g. methanol, acetone or acetonitrile) to watery eluents generally speeds up lipophilic ions.



## 4.4.2 Operation

### 4.4.2.1 Supply bottle

The supply bottle with the eluent must be connected as indicated in *chapter 2.8.1, page 28*. This is particularly important for eluents with volatile solvents (e.g. acetone).

Condensation in the eluent bottle must be avoided. Drop formation can change the concentration ratio in the eluent.

In the case of very sensitive measurements, we recommend that the eluent be stirred constantly with a magnetic stirrer (e. g. the 2.801.0010 with 6.2070.000).

### 4.4.2.2 Aspiration filter

To protect the IC system from foreign particles, we recommend aspirating the eluent via an aspiration filter (6.2821.090) (**12-2**). This aspiration filter must be replaced if it takes on a yellowish discoloration, and at least every 3 months.

### 4.4.2.3 Changing the eluent

Prevent any precipitations when changing the eluent. Immediately successive solutions must always be miscible. If the system has to be rinsed with organic solvents, use several solvents with rising or falling lipophilicity.

## 4.5 High pressure pump

### 4.5.1 Protection



#### CAUTION

The pump head is filled ex works with methanol/ultrapure water. It must be ensured that the eluent used is freely miscible with the solvent remaining in the pump head.

To protect the high pressure pump against **foreign particles**, we recommend that the eluent undergoes a **microfiltration** (filter 0.45 µm) before being aspirated via a 6.2821.090 aspiration filter (*see "Assembling eluent aspiration tubing", page 28*).

**Salt crystals** between the piston and seal cause abrasion particles which can find their way into the eluent. These lead to contaminated valves, a rise in pressure and in extreme cases scratched pistons. It is therefore essential to ensure that **no precipitates** can occur (*see chapter 4.4.2.3, page 66*).

**CAUTION**

In order to spare the pump seals, the pump should not be operated dry. Therefore ensure that the eluent supply is correctly connected and that there is enough eluent in the eluent bottle each time before switching on the pump.

**4.5.2 Maintenance****CAUTION**

Maintenance work on the high pressure pump may not be carried out unless the **instrument is switched off**.

**Pump head maintenance**

An unstable baseline (pulsation, flow fluctuations) is in many cases the result of contaminated valves (39-2), (39-3) or defective, leaking piston seals on the high pressure pump. Proceed as follows for cleaning contaminated valves and/or replacing worn parts such as pistons, piston seal and valves:

This maintenance work should be carried out at least once a year.

**Removing the pump head**

- 1 Switch off high pressure pump and wait until pressure is released.
- 2 Loosen the pressure screw on the inlet valve holder (17-6) and unscrew the pump head input capillary (17-7), the coupling (17-9), and the eluent aspiration tubing from the pump head.  
In the process, eluent will spill. Hold the eluent aspiration tubing up high and allow the eluent to flow back into the eluent bottle.
- 3 Unscrew the pump head outlet capillary (17-13) from the pump head.
- 4 Remove pump head from the pump housing by loosening the 4 fastening screws (17-5) using the hexagon key (6.2621.030). The main piston is on the left (viewed from the front), and the auxiliary piston is on the right.



## Cleaning/replacing the zirconium oxide piston

Clean one piston after the other as follows:

### 1 Removing the piston cartridge from the pump head

Loosen the piston cartridge with a wrench and unscrew from the pump head by hand.

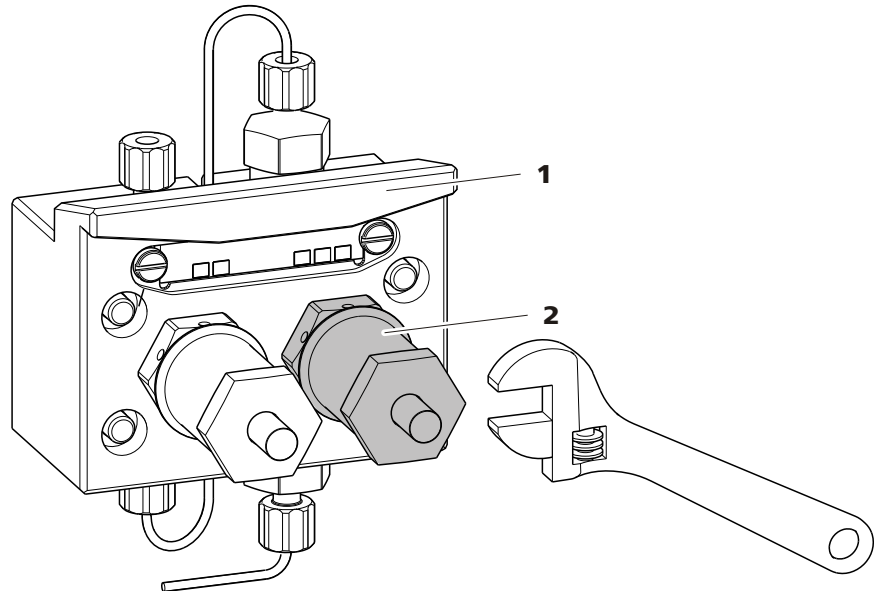

Figure 33 Pump head – removing the piston

1 Pump head

2 Piston cartridge

### 2 Dismantling the piston



#### CAUTION

On the inside of the piston cartridge there is a taut spring than can jump out of the piston cartridge if suddenly losing tension.

When opening the piston cartridge, hold pressure towards the spring and unscrew carefully.

- Loosen the screw of the piston cartridge with a wrench and unscrew carefully by hand and by holding pressure towards the taut spring.
- Remove the zirconium oxide piston and lay on a tissue.
- Remove the spring retainer, spring and the inner plastic sleeve from the piston cartridge and lay by.

- Remove the backup ring from the pump head and lay to the other parts.

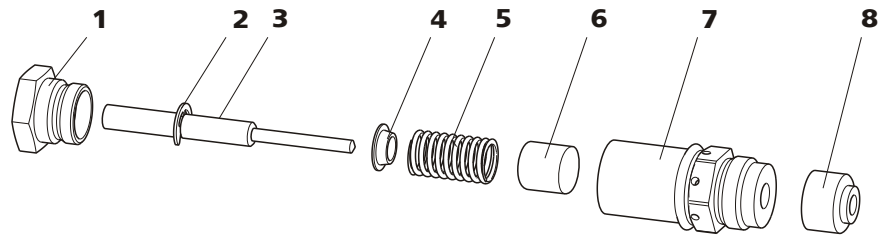

Figure 34 Components of the piston cartridge

<b>1</b>	<b>Piston cartridge screw</b>	<b>2</b>	<b>Retaining washer</b>
<b>3</b>	<b>Zirconium oxide piston with piston shaft</b> Order number: 6.2824.070	<b>4</b>	<b>Spring retainer</b>
<b>5</b>	<b>Spring</b> Order number: 6.2824.060	<b>6</b>	<b>Inner plastic sleeve</b> Protects from metallic abrasion.
<b>7</b>	<b>Piston cartridge</b>	<b>8</b>	<b>Backup ring</b>

### 3 Cleaning the components of the piston

- Clean zirconium oxide pistons contaminated by abrasion or deposits with fine abrasive cleaning powder, rinse particle free with ultrapure water and dry.  
Replace highly contaminated or scratched zirconium oxide pistons (spare part: 6.2824.070 zirconium oxide piston).
- Rinse the other parts of the piston and dry with a lint-free cloth.

### 4 Assembling the piston

- Insert the inner plastic sleeve, spring and spring retainer into the piston cartridge.
- Slide the zirconium oxide piston carefully into the piston cartridge until its tip emerges from the small opening of the piston cartridge.
- Attach screw and tighten by hand.

### Replacing the piston seal

The special tool (6.2617.010) (see figure 35, page 70) is necessary to remove the piston seal from the pump head. It consists of two parts: a tip



for removing the old piston seal and a sleeve for inserting the new piston seal.

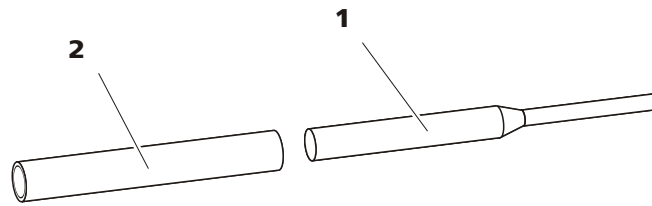

Figure 35 Tool for piston seal

**1 Pin**  
Tip for removing the old piston seal.

**2 Sleeve**  
Sleeve for inserting the new piston seal.



**CAUTION**

Screwing the special tool for the piston seal (6.2617.010) into the piston seal destroys this completely!

**1 Removing the piston seal**



**CAUTION**

Avoid touching the sealing surface in the pump head (17-4) with the tool.

Screw the special tool for the piston seal (35-1) with the narrow side just as far into the piston seal as the same can be removed.

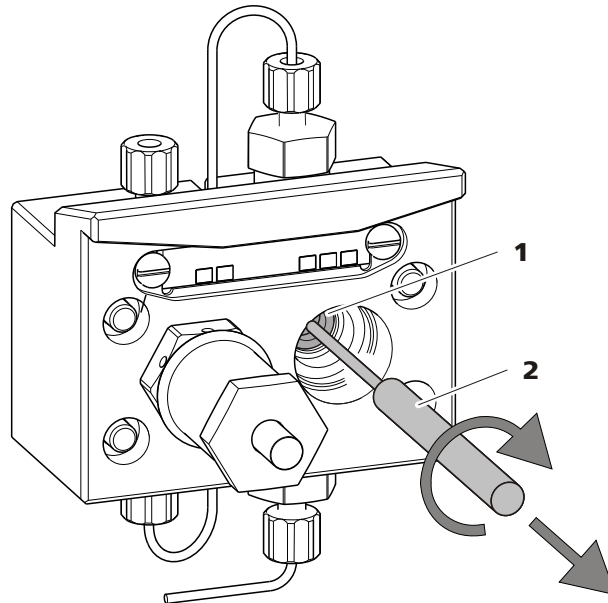

Figure 36 Removing the piston seal

**1** Piston seal

**2** Tool for piston seal  
Pin of the tool.

### 2 Inserting the new piston seal into the tool

Insert the new piston seal tightly by hand into the recess of the sleeve of the tool for the piston seal (35-2). The sealing springs must be visible from the outside.

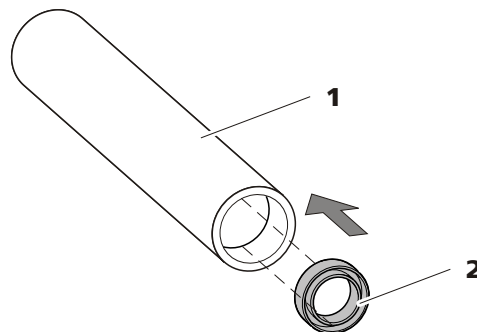

Figure 37 Inserting the piston seal into the tool

**1** Tool for piston seal (6.2617.010)  
Sleeve for inserting the new piston seal.

**2** Piston seal  
Order number: 6.2741.020

### 3 Inserting the new piston seal into the pump head

Guide the sleeve of the tool for the piston seal (35-2) with inserted piston seal into the pump head and press the seal with the wide end of the tool for the piston seal (35-1) into the pump head recess.

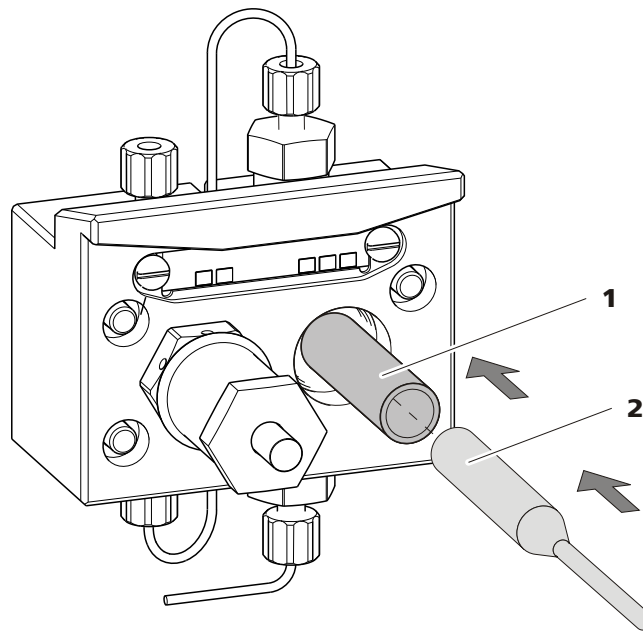

Figure 38 Inserting the piston seal into the pump head

#### 4 Replacing the piston cartridge

Screw the assembled piston cartridge back into the pump head and tighten, first by hand, then additionally by approx. 15° with a wrench.

### Cleaning the inlet valve and outlet valve

#### 1 Removing valves

- Unscrew the connection capillary for the auxiliary piston (17-1) from the outlet valve holder.
- Unscrew the holders for the inlet and outlet valves and remove the valves (39-3) and (39-2).

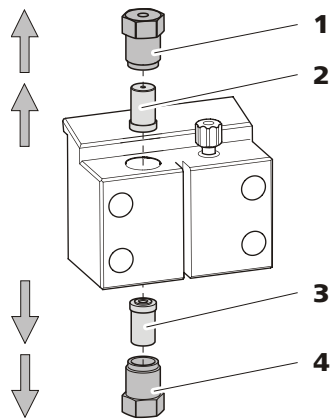

Figure 39 Removing valves

**1 Outlet valve holder****2 Outlet valve**

Order number: 6.2824.160

**3 Inlet valve**

Order number: 6.2824.170

**4 Inlet valve holder****2 Cleaning undissected valve**

Clean contaminated or blocked valves initially **without** dismantling them completely.

- Rinse the valve in eluent flow and counterflow direction using a spray bottle filled with ultrapure water, RBS solution or acetone.
- The rinsing effect is further increased through a short treatment (lasting for a maximum of 20 s) in an ultrasonic bath.

**NOTICE**

Longer lasting ultrasonic baths can damage the ruby ball of the valve.

Only if this cleaning is useless, dismantle the valves separately and clean the components.

**3 Dismantling valve**

Dismantle every valve separately.

**NOTICE**

For dismantling the valve the tool for valve cartridges (6.2617.020) is required.



- Place the valve with the seal faced downwards above the recess in the holder.
- Push the valve components out of the valve housing using the needle of the tool.

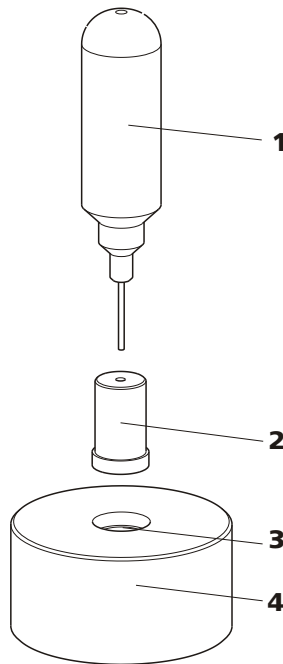

Figure 40 Dismantling valve

<p><b>1 Needle</b> For pushing the valve components out of the valve housing.</p>	<p><b>2 valve</b></p>
<p><b>3 Recess</b> For collecting the valve components.</p>	<p><b>4 Holder</b></p>

The components of the valve are collected in the recess of the holder.



**NOTICE**

The components of the valve are very small. In order not to lose them, put the components into a dish.

- The inlet valve and the outlet valve consist of the same, just differently arranged components (see figure 41, page 75).

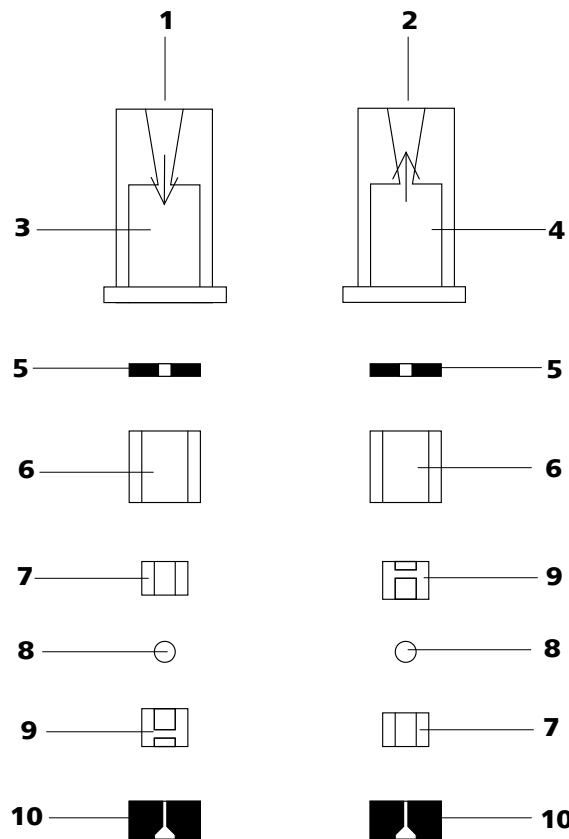

Figure 41 Components of the inlet valve and outlet valve

<b>1</b>	<b>Inlet valve (6.2824.170)</b>	<b>2</b>	<b>Outlet valve (6.2824.160)</b>
<b>3</b>	<b>Inlet valve housing</b>	<b>4</b>	<b>Outlet valve housing</b>
<b>5</b>	<b>Sealing ring (black)</b>	<b>6</b>	<b>Sleeve</b>
<b>7</b>	<b>Sapphire sleeve</b> The shiny side must point to ruby ball.	<b>8</b>	<b>Ruby ball</b>
<b>9</b>	<b>Ceramic holder for ruby ball</b>	<b>10</b>	<b>Seal</b> The larger opening must point outwards.

#### 4 Cleaning the components of the valve

Rinse the valve components with ultrapure water and/or acetone and dry with a lint-free cloth.

#### 5 Reassembling the valve

Reassemble valve components *according to figure 41, page 75*.

- Insert the seal with the larger opening faced downwards into the recess of the tool.
- Lay the other valve components above another in the correct sequence (*see figure 41, page 75*).



- Place over the valve housing and hold it tightly.
- By tilting the tool, the valve components slide into the valve housing.
- Press the seal by hand well on the valve housing.

## 6 Checking the flow direction

Rinse the valve in the direction of the arrow on the valve housing and check whether liquid is escaping on the other end.

If this is not the case, the valve has to be dismantled again and be reassembled correctly (*see figure 41, page 75*).

## 7 Inserting the valves back into the pump head



### CAUTION

If by mistake, the inlet valve is mounted instead of the outlet valve, an extreme pressure builds up within the working cylinder, which can destroy the piston seal!

When inserting the valves, please take into account that the liquid is being pumped through the pump head from bottom to top.

- Insert the inlet valve into the inlet valve holder the way the seal is visible.
- Screw the inlet valve holder into the bottom of the pump head and tighten with a wrench (**39-4**).
- Insert the outlet valve into the outlet valve holder the way the seal is visible.
- Screw the outlet valve holder into the top of the pump head and tighten with a wrench (**39-1**).

## Mounting the pump head



### NOTICE

To prevent the pump head from being positioned the wrong way, it is provided with different bore hole depths for the fastening bolts, i. e. a fastening bolt is longer than all others. The bore hole with the greatest depth must therefore be assigned to the longest bolt. If this is not the case, the pump will not function perfectly.

- 1** Mount the pump head on the pump again using the four fastening screws (17-5). Firmly tighten the screws with the hexagon key (6.2621.030).
- 2** Screw connection capillaries (17-1), (17-7) and (17-13) onto the pump head again.

## 4.6 Inline filter

### 4.6.1 Maintenance

The inline filter (6.2821.120) comprises the filter housing (42-2), the filter screw (42-4) and the filter (42-3). New filters (42-3) are available under the order number 6.2821.130 (10 items).

The filters (6.2821.130) (42-3) should be changed every 3 months (more frequently at higher backpressure).

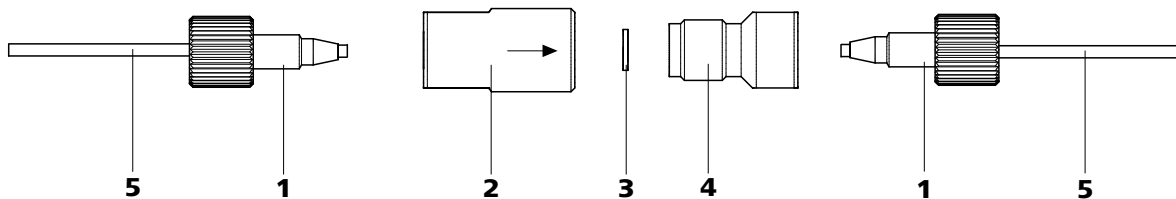

Figure 42 Change filters (of the inline filter)

**1 PEEK pressure screws, short**  
(6.2744.070)

**3 Filter (6.2821.130)**  
Packaging contains 10 items.

**5 Connection capillaries**

**2 Filter housing**  
Housing of the inline filter. Part of the 6.2821.120 accessories.

**4 Filter housing**  
Screw of the inline filter. Part of the 6.2821.120 accessories.



## Changing the filter

The flow must be stopped before changing the filter.

### 1 Removing the inline filter

- Unscrew the pressure screws (42-1) from the inline filter.

### 2 Unscrewing the filter screw

- Screw the filter screw (42-4) out of the filter housing (42-2) with the aid of two adjustable wrenches (6.2621.000).

### 3 Inserting the filter

- Remove the old filter (42-3) using tweezers.
- Place the new filter (42-3) flat in the filter housing (42-2) using tweezers.

### 4 Mounting filter screw

- Screw the filter screw (42-4) back into the filter housing (42-2) and tighten by hand. Then additionally tighten slightly with two adjustable wrenches (6.2621.000).

### 5 Remounting the inline filter

- Screw pressure screws (42-1) back onto the inline filter.

### 6 Rinsing the inline filter

- Dismantle the guard column (if present) and the separation column and replace with a coupling (6.2744.040).
- Rinse the instrument with eluent.

## 4.7 Inline sample preparation

To protect the separation column (*see chapter 2.21, page 57*) against foreign particles which can affect the separating efficiency, we recommend that all samples undergo a microfiltration (filter 0.45 µm). The ultrafiltration cell can be used for **filtration** (*see manual of the IC Equipment for Ultrafiltration*).

Samples containing significant amounts of **gas** should be degassed. The sample degasser (*see chapter 2.13, page 40*) is used for degassing.

**Matrix-loaded** samples (e.g. blood, oil) should be prepared for the measurement by means of dialysis (*see manual on the IC Equipment for Dialysis*).

If the concentration of the sample is too high, the sample should be **diluted** before feeding (*see documentation on the IC Equipment for Sample Dilution*).

For the sample preparation methods **Neutralization** (replacement of e.g. Na<sup>+</sup> with H<sup>+</sup>) and **cation exchange** (replacement of e.g. heavy metals with H<sup>+</sup>), a sample preparation module (SPM) is used.

For an overview of all Metrohm inline sample preparation methods go to the following website: <http://misp.metrohm.com>

## 4.8 Rinsing the sample path

Before a new sample can be measured, the sample path must be rinsed with it so that the measuring result is not falsified by the previous sample (**Sample carry-over**).

In the case of automated sample feeding, the rinsing time should be at least 3 times the **transfer time**.

The transfer time is the time required by the sample to flow from the sample vessel to the end of the sample loop. The transfer time depends on the pump capacity of the peristaltic pump or the Dosino used, the total capillary volume and the volume of the gas removed by the sample degasser (if used) - in other words the amount of gas in the sample.



### Ascertaining the transfer time

To ascertain the transfer time, proceed as follows:

#### 1 Emptying the sample path

Pump air through the sample path (pump tubing, tubing connections, capillary in the degasser, sample loop) for several minutes until all liquid is displaced by the air.

#### 2 Aspirating the sample and measuring time

Aspirate a sample typical for the later application and use a stop watch to measure the time required by the sample to travel from the sample vessel to the end of the sample loop.

The time measured corresponds to the "transfer time". The rinsing time should be at least 3 times the transfer time.

### Checking the rinsing time

It is possible to determine whether the rinsing time is adequate via a direct measurement of the sample carry-over. Proceed as follows:

#### 1 Preparing two samples

- **Sample A:** A typical sample for the application.
- **Sample B:** Ultrapure water.

#### 2 Determining "Sample A"

Let "Sample A" pass through the sample path for the duration of the rinsing time, then inject and measure.

#### 3 Determining "Sample B"

Let "Sample B" pass through the sample path for the duration of the rinsing time, then inject and measure.

#### 4 Calculating the sample carry-over

The degree of the sample carry-over corresponds to the ratio of the peak areas of the measurement for sample B to the measurement for sample A. The lower the ratio, the lower the sample carry-over. This ratio can be modified by varying the rinsing time – thus allowing the rinsing time required for the application to be ascertained.

## 4.9 Sample degasser

### 4.9.1 Operation

If you are working with sample degassing, the longer "transfer time" (*see Ascertaining the transfer time, page 80*) means that it is also necessary to rinse for longer (with the subsequent sample). The rinsing time should be at least 3 times the "transfer time" so as to minimize the carry-over effects. The "transfer time" depends on the pump capacity, the total capillary volume and the volume of the removed gas (i.e. the gas amount in the sample).



#### NOTICE

The rinsing time increases by at least 2 minutes when the sample degasser is used.

## 4.10 Peristaltic pump

### 4.10.1 Operation

The pumping capacity of the peristaltic pump depends on the drive speed (set via software), the contact pressure and, above all, the internal diameter of the pump tubing. Depending on the application, different pump tubings are used.



#### CAUTION

The service life of the pump tubings also depends on the contact pressure. Therefore fully lift the tubing cartridges by loosening the snap-action lever (**24-10**) on the right-hand side if the peristaltic pump is to be turned off for a longer period. Once set, the contact pressure remains unaffected.



#### CAUTION

The 6.1826.xxx pump tubings consist of PVC or PP and therefore must not be used for rinsing with solutions containing acetone. In this case, use other pump tubings or use another pump for rinsing.



## 4.10.2 Maintenance

### 4.10.2.1 Pump tubings

Pump tubings used for the peristaltic pump are consumables with a limited lifetime.

LFL pump tubings with three stoppers are inserted into the tubing cartridge in such a way that the cartridge is located between two stoppers. This results in two possible positions for the tubing cartridge. If the pump tubing was to show pronounced signs of wear, you can insert it a second time in the other position.

Replace the pump tubings periodically, approx. every four weeks if used continuously.

#### Pump tubing selection

Pump tubing can differ in terms of material, diameter and thus flow rate. Different pump tubing is used depending on the application.

The following table shows the properties and areas of application of the pump tubings:

Table 2 Pump tubings

Order number	Name	Material	Inner diameter	Use
6.1826.020	Pump tubing (blue/blue), 2 stoppers	PVC (Tygon® ST)	1.65 mm	Pump tubing for online IC instruments and automation in voltammetry.
6.1826.310	Pump tubing LFL (orange/green), 3 stoppers	PVC (Tygon®)	0.38 mm	Pump tubing for bromate determination using the triiodide method.
6.1826.320	Pump tubing LFL (orange/yellow), 3 stoppers	PVC (Tygon®)	0.48 mm	For acceptor solutions for Inline Dialysis and for Inline Ultrafiltration.
6.1826.330	Pump tubing LFL (orange/white), 3 stoppers	PVC (Tygon®)	0.64 mm	No special applications.
6.1826.340	Pump tubing LFL (black/black), 3 stoppers	PVC (Tygon®)	0.76 mm	For sample solution in Inline Dialysis.
6.1826.360	Pump tubing LFL (white/white), 3 stoppers	PVC (Tygon®)	1.02 mm	For sample transfer.

Order number	Name	Material	Inner diameter	Use
6.1826.380	Pump tubing LFL (gray/gray), 3 stoppers	PVC (Tygon®)	1.25 mm	For Inline Dilution.
6.1826.390	Pump tubing LFL (yellow/yellow), 3 stoppers	PVC (Tygon®)	1.37 mm	For sample solution in Inline Ultrafiltration.

#### 4.10.2.2 Pump tubing connection with filter

The 6.2821.130 filters (43-2) should be changed every 3 months, more frequently at higher backpressure.

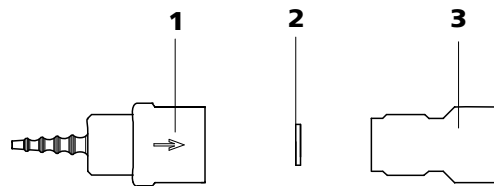

Figure 43 Pump tubing connection – Changing the filter

**1 Tubing olive**

**2 Filter 6.2821.130**  
Packaging contains 10 items.

**3 Filter housing**

#### Replacing the filter

##### 1 Unscrewing filter screw

- Screw the filter screw (43-3) out of the tubing olive (43-1) with the aid of two 6.2621.000 adjustable wrenches.

##### 2 Replacing the filter

- Remove the old filter (43-2) with tweezers.
- Place the new filter (43-2) flat in the tubing olive (43-1) with tweezers.

##### 3 Mounting filter screw

- Screw the filter screw (43-3) back into the tubing olive (43-1) and tighten by hand. Then additionally tighten with two 6.2621.000 adjustable wrenches.



## 4.11 Injection valve

### 4.11.1 Protection

To prevent contamination of the injection valve, a 6.2821.120 inline filter (see chapter 2.11, page 38) should be mounted between the high pressure pump and the pulsation damper.

## 4.12 Conductivity detector

### 4.12.1 Maintenance



#### CAUTION

The conductivity detector must not be opened!



#### WARNING

When rinsing the detector, the pressure must not exceed **5 MPa**. In order to ensure this, the maximum pressure of the high pressure pump must be set to **5 MPa** in MagIC Net.

If the conductivity detector is blocked, you should first of all check whether the blockage results from the capillary ends being pressed together too firmly. In this case, shorten the detector input capillary (30-3) or the detector output capillary (31-2) by several millimeters.

If this does not help, the conductivity detector can be rinsed against the normal flow direction. For this, connect the high pressure pump to the detector output capillary (31-2) and rinse - **the pressure may not exceed 5 MPa**.

## 4.13 Separation column

### 4.13.1 Separating efficiency

Which analysis quality can be attained, depends to a great extent on the separating efficiency of the separation column used. The separating efficiency of the selected separation column must be sufficient for the analysis problems present. If difficulties occur, you should always first check the quality of the separation column by recording a standard chromatogram.

You can find detailed information on the separation columns available from Metrohm in the leaflet provided along with your separation column, in the **Metrohm IC-Column Program** (available via your Metrohm agent) or in the Internet at <http://www.metrohm.com> in the product area Ion chromatography. You can request free information on special IC applications in the corresponding "**Application Bulletins**" or "**Application Notes**", which are available in the Internet at <http://www.metrohm.com> in the Applications area or via the Metrohm agent responsible.

### 4.13.2 Protection

To protect the separation column against foreign particles, which can affect the separating efficiency, we recommend that both the eluent and the samples undergo a microfiltration (filter 0.45 µm) before being aspirated via the aspiration filter (6.2821.090).

We recommend always to use a guard column (*see chapter 2.20, page 56*). This protects the separation column and considerably increases its service life. Information regarding which guard column is suitable for your separation column can be found in the **Metrohm IC Column Program** (which is available from your Metrohm agent), the leaflet provided along with your separation column, the product information on the separation column at <http://www.metrohm.com> (product area Ion Chromatography) or obtained directly from your agent.

The pulsation absorber (*see chapter 2.12, page 39*) must be installed in order to protect the column material from pressure concussion caused by injection.

### 4.13.3 Storage

Always store the separation columns sealed and filled according to the data of the column manufacturer when not using them.



#### 4.13.4 Regeneration



##### NOTICE

---

The regeneration is considered as the last measure, and not to be carried out regularly.

If the separating properties of the column have deteriorated, the column can be regenerated according to the specifications of the column manufacturer. In the case of separation columns available from Metrohm, the specification for regeneration can be found on the leaflet provided along with each column.

## 5 Troubleshooting

### 5.1 Problems and their solutions

<b>Problem</b>	<b>Cause</b>	<b>Remedy</b>
<b>Marked drop in pressure.</b>	<i>Leak in the system.</i>	Check all capillary connections and seal leaks, if necessary ( <i>see chapter 2.5, page 17</i> ).
	<i>High pressure pump – contaminated pump valves.</i>	Clean pump valves ( <i>see chapter 4.5.2, page 67</i> ).
<b>The baseline has a large amount of noise.</b>	<i>Eluent – Leakage in eluent path.</i>	Check eluent path.
	<i>Eluent – Blockage in eluent path.</i>	Check eluent path.
	<i>High pressure pump – defective piston seals.</i>	Replace ( <i>see chapter 4.5.2, page 67</i> ) piston seals .
	<i>Pulsation damper not connected.</i>	Connect the pulsation damper ( <i>see Chapter 2.12, Page 39</i> ).
	<i>Pulsation absorber not connected. or defective.</i>	Connect pulsation absorber ( <i>see chapter 2.12, page 39</i> ). or replace it.
	<i>Thermal equilibrium not yet attained.</i>	Condition ( <i>see Chapter 3.2, Page 61</i> ) instrument with the column thermostat ( <i>see Chapter 2.16, Page 49</i> ) switched on .
<b>The baseline is drifting.</b>	<i>Leak in the system.</i>	Check all capillary connections and seal leaks, if necessary ( <i>see chapter 2.5, page 17</i> ).
	<i>Eluent – Evaporation of organic solvent in eluent.</i>	<ul style="list-style-type: none"> <li>▪ Check the eluent bottle cap (<i>see figure 13, page 30</i>).</li> <li>▪ Stir the eluent.</li> </ul>
	<i>Inline filter (6.2821.120) blocked.</i>	Replace the filter (6.2821.130) ( <i>see chapter 4.6, page 77</i> ).
<b>The pressure in the system markedly increases.</b>	<i>Conductivity detector blocked.</i>	<ul style="list-style-type: none"> <li>▪ Shorten capillary ends by several mm (<i>see chapter 4.12.1, page 84</i>).</li> <li>▪ Rinse detector against the normal flow direction (<i>see chapter 4.12.1, page 84</i>).</li> </ul>



<b>Problem</b>	<b>Cause</b>	<b>Remedy</b>
	<i>Guard column – blocked.</i>	Replace guard column ( <i>see chapter 2.20, page 56</i> ).
	<i>Separation column – blocked.</i>	<ul style="list-style-type: none"> <li>▪ Regenerate separation column (<i>see chapter 4.13.4, page 86</i>).</li> <li>▪ Replace separation column (<i>see "Connecting and rinsing the separation column", page 58</i>).</li> </ul> <p>Note: Samples should always be microfiltered (<i>see chapter 4.7, page 79</i>).</p>
	<i>Injection valve – valve blocked.</i>	Have the valve cleaned (by Metrohm service technicians).
<b>The retention times in the chromatogram have changed unexpectedly.</b>	<i>Separation column – diminished separating efficiency.</i>	<ul style="list-style-type: none"> <li>▪ Regenerate separation column (<i>see chapter 4.13.4, page 86</i>).</li> <li>▪ Replace separation column (<i>see "Connecting and rinsing the separation column", page 58</i>).</li> </ul>
	<i>Eluent – Gas bubbles in eluent.</i>	<ul style="list-style-type: none"> <li>▪ Check the connectors of the eluent degasser (<i>see chapter 2.9, page 32</i>).</li> <li>▪ Deaerate high-pressure pump (<i>see chapter 2.10.2, page 36</i>).</li> </ul>
	<i>High pressure pump – defective.</i>	Request Metrohm Service.
<b>Peak areas are lower than expected.</b>	<i>Sample – leak in the sample path.</i>	Check the sample path.
	<i>Sample – blockage in the sample path.</i>	Check the sample path.
	<i>Sample – sample loop not (completely) filled.</i>	Prolong the sample transfer time.
	<i>Sample – gas bubbles in the sample.</i>	Use sample degasser ( <i>see chapter 2.13, page 40</i> ).
<b>The peristaltic pump is pumping too little.</b>	<i>Peristaltic pump – contact pressure too weak.</i>	Correctly set contact pressure ( <i>see "Set flow rate", page 46</i> ).
	<i>Peristaltic pump – filter blocked.</i>	Replace the filter ( <i>see chapter 4.10.2.2, page 83</i> ).

<b>Problem</b>	<b>Cause</b>	<b>Remedy</b>
	<i>Peristaltic pump – pump tubing defective.</i>	Replace pump tubing ( <i>see chapter 4.10.2.1, page 82</i> ).
<b>Data of the separation column cannot be read.</b>	<i>Column chip contaminated.</i>	Clean the contact surfaces of the column chip (with alcohol).
	<i>Column chip defective.</i>	<ol style="list-style-type: none"> <li>1. Save column configuration in MagIC Net™.</li> <li>2. Notify Metrohm Service.</li> </ol>
<b>Individual peaks are greater than expected.</b>	<i>Sample – carry-over of the samples from previous measurement.</i>	Rinse system longer between two samples.
<b>The background conductivity is too high.</b>	<i>Wrong eluent.</i>	Change the eluent ( <i>see chapter 4.4.2.3, page 66</i> ).
<b>The retention times are poorly reproducible.</b>	<i>Eluent – Leakage in eluent path.</i>	Check eluent path.
	<i>Eluent – Blockage in eluent path.</i>	Check eluent path.
	<i>Eluent – Gas bubbles in eluent.</i>	<ul style="list-style-type: none"> <li>▪ Check the connectors of the eluent degasser (<i>see chapter 2.9, page 32</i>).</li> <li>▪ Deaerate high-pressure pump (<i>see chapter 2.10.2, page 36</i>).</li> </ul>
<b>Chromatograms have poor resolution</b>	<i>Separation column – diminished separating efficiency.</i>	<ul style="list-style-type: none"> <li>▪ Regenerate separation column (<i>see chapter 4.13.4, page 86</i>).</li> <li>▪ Replace separation column (<i>see "Connecting and rinsing the separation column", page 58</i>).</li> </ul>
<b>Conductivity detector is not recognized in the software</b>	<i>No connection.</i>	<ul style="list-style-type: none"> <li>▪ Check the cable connection (<b>31-1</b>).</li> <li>▪ Turn the instrument off and on again (after 15 seconds).</li> </ul>
<b>Extreme spread of the peaks in the chromatogram. Splitting (dual peaks)</b>	<i>Capillary connections – dead volume in the system.</i>	Check connections ( <i>see chapter 2.5, page 17</i> ) (use PEEK capillaries with an internal diameter of 0.25 mm between the injection valve and detector).
	<i>Guard column – diminished performance.</i>	<ul style="list-style-type: none"> <li>▪ Replace guard column (<i>see chapter 2.20, page 56</i>).</li> </ul>



<b>Problem</b>	<b>Cause</b>	<b>Remedy</b>
	<i>Separation column – dead volume at column head.</i>	<ul style="list-style-type: none"> <li>Install the separation column in reverse flow direction (if permitted by the leaflet) and rinse into a beaker.</li> <li>Replace separation column (see "Connecting and rinsing the separation column", page 58).</li> </ul>
<b>Precision problems - the measured values are highly scattered.</b>	<i>Sample – gas bubbles in the sample.</i>	Use sample degasser (see chapter 2.13, page 40).
	<i>Injection valve – sample loop.</i>	Check installation of the sample loop (see chapter 2.15.1, page 47).
	<i>Sample – rinsing volume too low.</i>	Increase rinsing time (see chapter 4.8, page 79).
	<i>Injection valve – defective.</i>	Request Metrohm Service.
<b>Vacuum is not being built</b>	<i>Eluent degasser – <b>Vacuum</b> connector on the rear of the instrument not (tightly) sealed.</i>	<ul style="list-style-type: none"> <li>Seal the <b>Vacuum</b> connector tightly with a threaded stopper (6.1446.040).</li> </ul>

## 6 Technical specifications

### 6.1 Reference conditions

The technical specifications listed in this chapter refers to the following reference conditions:

<i>Ambient temperature</i>	+25 °C ( $\pm 3$ °C)
<i>Instrument status</i>	> 40 minutes in operation (equilibrated)

### 6.2 Device

<i>IC system</i>	<ul style="list-style-type: none"> <li>▪ Metal-free IC system</li> <li>▪ Compact system with modular design</li> <li>▪ Up to two complete chromatographic systems in one housing</li> </ul>
<i>Material</i>	Painted polyurethane hard foam without CFCs, fire class V0
<i>Operating pressure range</i>	<ul style="list-style-type: none"> <li>▪ 0...50 MPa (500 bar) high pressure pump</li> <li>▪ 0...35 MPa (350 bar) standard-PEEK system</li> </ul>
<i>Intelligent components</i>	iPump, iDetector, iColumn, MagIC Net

### 6.3 Leak sensor

<i>Type</i>	Electronic, no calibration necessary
-------------	--------------------------------------

### 6.4 Ambient conditions

<i>Operation</i>	
<i>Ambient temperature</i>	+5...+45 °C
<i>Humidity</i>	20...80 % relative humidity
<i>Storage</i>	
<i>Ambient temperature</i>	-20...+70 °C
<i>Transport</i>	
<i>Ambient temperature</i>	-40...+70 °C



## 6.5 Housing

### Dimensions

<i>Width</i>	365 mm
<i>Height</i>	642 mm
<i>Depth</i>	380 mm

*Material of base tray, housing and flask holder* Polyurethane hard foam (PUR) with flame retardation for fire class V0, CFC-free, painted

### Operating elements

<i>Indicators</i>	LED for power display
<i>On/Off switch</i>	On the rear of the instrument

## 6.6 Eluent degasser

<i>Material</i>	Fluoropolymer
<i>Resistance to solvents</i>	No restriction (except PFC)
<i>Time to establish vacuum</i>	< 60 s

## 6.7 High pressure pump

<i>Type</i>	<ul style="list-style-type: none"> <li>▪ Serial dual-piston pump</li> <li>▪ Intelligent pump head recognition</li> <li>▪ Chemically inert</li> <li>▪ Metal-free pump heads</li> <li>▪ Materials in contact with the eluent: PEEK, ZrO<sub>2</sub>, PTFE/PE</li> <li>▪ Self-optimizing flow and pressure</li> </ul>
-------------	--

### Flow rate

<i>Adjustable flow range</i>	0.001...20.0 mL/min
<i>Flow increment</i>	1 µL/min
<i>Reproducibility of the eluent flow</i>	< 0.1 % deviation

**Pressure range**

<i>Pump</i>	0...50.0 MPa (0...500 bar)
<i>Pump head</i>	0...35.0 MPa (0...350 bar) (applies for the standard PEEK pump head)
<i>Residual pulsation</i>	< 1 %

**Safety shutdown**

<i>Function</i>	Automatic shutdown upon reaching the pressure limit values
<i>Maximum pressure limit</i>	<ul style="list-style-type: none"> <li>▪ Adjustable from 0.1...50 MPa (1...500 bar)</li> <li>▪ The pump is automatically shut down at the first piston stroke above the maximum limit value</li> </ul>
<i>Minimum pressure limit</i>	<ul style="list-style-type: none"> <li>▪ Adjustable from 0...49 MPa (0...490 bar)</li> <li>▪ The shutdown mechanism is inactive at 0 MPa</li> <li>▪ The shutdown mechanism only becomes active 2 minutes after system start</li> <li>▪ The pump is automatically shut down after 3 piston strokes below the minimum pressure limit</li> </ul>

*Gradient capacity* Isocratic or gradient (extendable to quaternary)

*Profile* Step, linear, convex and concave

*Resolution* < 1 nL/min flow increments

**6.8 Sample degasser**

<i>Material</i>	Fluoropolymer
<i>Resistance to solvents</i>	No restriction (except PFC)
<i>Time to establish vacuum</i>	< 60 s

**6.9 Peristaltic pump**

<i>Type</i>	2-channel peristaltic pump
<i>Rotating direction</i>	Counterclockwise/Clockwise rotation
<i>Rotational speed</i>	0...42 rpm in 7 stages at 6 rpm.
<i>Pumping properties</i>	0.3 mL/min at 18 rpm; with 6.1826.320 standard pump tubing.
<i>Material of pump tubings</i>	recommended: Tygon Long Flex Life



## 6.10 Injection valve

<i>Actuator time</i>	typ. 100 ms
<i>Max. operating pressure</i>	35 MPa (350 bar)
<i>Material</i>	PEEK

## 6.11 Column thermostat

<i>Type</i>	Peltier technique thermostat for two intelligent separation columns
<i>Adjustable temperature range</i>	0...+ 80 °C, in increments of 0.1 °C
<i>Heating</i>	Ambient temperature +50 °C
<i>Cooling</i>	Ambient temperature –20 °C
<i>Temperature reproducibility</i>	± 0.2 °C
<i>Stability</i>	< 0.05 °C
<i>Heating up time</i>	< 30 minutes from 20 to 50 °C
<i>Cooling time</i>	< 40 minutes from 50 to 20 °C

## 6.12 Conductivity measuring system

<i>Type</i>	<ul style="list-style-type: none"> <li>▪ Microprocessor-controlled Digital Signal Processing (DSP technology)</li> <li>▪ Intelligent detector with 6 reference chromatograms</li> </ul>
<i>Measuring range</i>	0...15000 µS/cm single range
<i>Noise</i>	< 0.1 nS at 1 µS/cm
<i>Drift</i>	< 0.2 nS/cm per hour
<i>Measuring rate</i>	10 measurements per second for optimum results without filtering
<i>Resolution</i>	0.0047 nS/cm
<i>Baseline</i>	Noise < 3 nS/cm typical without suppression
<i>Conductivity detector</i>	
<i>Cell volume</i>	0.8 µL
<i>Cell constant</i>	<ul style="list-style-type: none"> <li>▪ Individual calibration data saved in the detector</li> <li>▪ adjustable range: 13.0...21.0 /cm</li> </ul>

<i>Electrodes</i>	Ring-shaped electrodes made from stainless steel
<i>Materials in contact with eluent</i>	Chemically inert PCTFE
<i>Maximum operating pressure</i>	5.0 MPa (50 bar)
<i>Cell temperature</i>	20...50 °C in increments of 5 °C
<i>Temperature stability</i>	< 0.001 °C
<i>Temperature compensation</i>	0...5 %/K adjustable, default 2.3 %/K
<i>Heating up time</i>	< 30 minutes (40 °C)

## 6.13 Power connection

<i>Required supply voltage</i>	100 - 240 V ± 10% (autosensing)
<i>Required frequency</i>	50 - 60 Hz ± 3 Hz (autosensing)
<i>Power consumption</i>	<ul style="list-style-type: none"> <li>▪ 65 W for typical analysis application</li> <li>▪ 25 W standby (conductivity detector to 40 °C)</li> </ul>
<i>Power supply unit</i>	<ul style="list-style-type: none"> <li>▪ Up to 300 W maximum, electronically monitored</li> <li>▪ Internal fuse 3.15 A</li> </ul>

## 6.14 Interfaces

### USB

<i>Entry</i>	1 USB upstream, type B (for connection to the PC)
<i>Exit</i>	2 USB downstream, type A

*MSB* 2 MSB 8-pin Mini DIN (female) (for Dosino, stirrer, remote lines, etc.)



### CAUTION

When connecting an instrument to the MSB connector you **must** switch off the 850 Professional IC .

<i>Detector</i>	2 15-pin high-density DSUB (female)
<i>Column recognition</i>	3 (including 2 in the column thermostat ( <i>see chapter 2.16, page 49</i> ))

## 6.15 Weight



- Leak sensor* 1 jack plug
- Further connections*
- 1 15-pin DSUB (female)

## 6.15 Weight

- 1.850.1050* 28.3 kg (without accessories)
- 1.850.9010 (conductivity detector)* 2.3 kg (with accessories)
- Transport carriage (rollers and handle)* 1.8 kg

## 7 Accessories

Up-to-date information on the scope of delivery and optional accessories for your product can be found on the Internet. You can download this information using the article number as follows:

### Downloading the accessories list

- 1 Enter <https://www.metrohm.com/> into your Internet browser.
- 2 Enter the article number (e.g. **2.850.1050**) into the search field.  
The search result is displayed.
- 3 Click on the product.  
Detailed information regarding the product is shown on various tabs.
- 4 On the **Included parts** tab, click on **Download the PDF**.  
The PDF file with the accessories data is created.



#### NOTICE

Once you have received your new product, we recommend downloading the accessories list from the Internet, printing it out and keeping it together with the manual for reference purposes.



- Eluent bottle ..... 28  
 Eluent degasser ..... 32  
 Guard column ..... 56  
 High pressure pump ..... 34  
 Initial installation ..... 9  
 Injection valve ..... 47, 94  
 Leak sensor ..... 22  
 Peristaltic pump ..... 43  
 Pulsation absorber ..... 39  
 Pump tubings ..... 43  
 Sample degasser ..... 40  
 Separation column ..... 57
- Interface  
 MSB ..... 95  
 USB ..... 95
- Interfaces ..... 95  
 Further connections ..... 96  
 Leak sensor ..... 96
- L**  
 Leak ..... 67  
 Leak sensor  
 Installation ..... 22  
 Interface ..... 96  
 Technical specifications ..... 91  
 Leak-tightness ..... 60, 61  
 Leaking piston seals ..... 67  
 Loop  
 see also "Sample loop" ..... 49
- M**  
 Maintenance  
 Conductivity detector ..... 84  
 High pressure pump ..... 66  
 Injection valve ..... 84  
 Peristaltic pump ..... 81  
 Pump head ..... 67  
 Material ..... 92  
 Matrix elimination ..... 10  
 Measuring range ..... 94  
 MPak  
 Holder ..... 21  
 MSB ..... 95
- N**  
 Noise ..... 94
- O**  
 Oil ..... 79  
 Operation  
 Peristaltic pump ..... 81  
 Sample degasser ..... 81
- P**  
 Peristaltic pump  
 Installation ..... 43  
 Maintenance ..... 81  
 Operation ..... 81  
 Principle ..... 42  
 Technical specifications ..... 93  
 Piston seal ..... 67  
 Pistons of the high pressure pump  
 ..... 67  
 Power connection ..... 55, 95  
 Power consumption ..... 95  
 Power supply unit ..... 95  
 Precipitates ..... 66  
 Preconcentration ..... 13  
 Pressure limit ..... 93  
 Pressure range ..... 93  
 Pressure screws  
 Connection ..... 17  
 Protection  
 Injection valve ..... 84  
 Inline filter ..... 38  
 Pulsation ..... 67  
 Pulsation absorber  
 Installation ..... 39  
 Pump head  
 Maintenance ..... 67  
 Pump tubings  
 Installing ..... 43  
 Overview ..... 82  
 Service life ..... 81  
 Purge valve ..... 34
- R**  
 Reference conditions ..... 91  
 Regeneration ..... 63  
 Rinsing  
 Conductivity detector ..... 84  
 Guard column ..... 57  
 Pump tubings ..... 81  
 Sample path ..... 79  
 Separation column ..... 59  
 Rinsing time ..... 80  
 Rise in pressure ..... 66  
 Rollers ..... 19
- S**  
 Safety instructions ..... 6  
 Safety shutdown ..... 93  
 Sample  
 Carry-over ..... 79  
 Sample loop ..... 49  
 Transfer time ..... 80  
 Sample degasser  
 Installation ..... 40  
 Operation ..... 81  
 Technical specifications ..... 93  
 Sample dilution ..... 4  
 Sample loop ..... 49  
 Sample path  
 Rinsing ..... 79  
 Sample preparation ..... 79  
 Screws  
 Connection ..... 17  
 Separation column  
 Installation ..... 57  
 Protection ..... 3, 39, 85  
 Regeneration ..... 86  
 Rinsing ..... 59  
 Separating efficiency ..... 85  
 Storage ..... 85  
 Service ..... 6, 63  
 Shutting down ..... 64  
 Standard addition ..... 13  
 Start-up ..... 60  
 Storage ..... 91  
 Supply voltage ..... 6, 95
- T**  
 Technical data  
 Column thermostat ..... 94  
 Conductivity measuring system  
 ..... 94  
 Technical specifications  
 Detector ..... 95  
 Eluent degasser ..... 92  
 High pressure pump ..... 92  
 Interfaces ..... 95  
 Leak sensor ..... 91  
 Peristaltic pump ..... 93  
 Reference conditions ..... 91  
 Sample degasser ..... 93  
 Temperature ..... 91  
 Thermostat  
 see also "Column thermostat"  
 ..... 49  
 Transfer procedure ..... 10  
 Transfer time ..... 80  
 Transport ..... 91  
 Rollers ..... 19  
 Transport locking screws ..... 22  
 Tubing ..... 10  
 Tubing pump  
 See also "Peristaltic pump" . 42  
 Tubings  
 Installation ..... 17
- U**  
 USB ..... 95



**V**

Vacuum pump  
Protection ..... 22

Valve  
see also "Injection valve" .... 47

Valves of the high pressure pump  
..... 75