



CH-9101 Herisau/Switzerland  
Phone +41 71 353 85 85  
Fax +41 71 353 89 01  
EMail [info@metrohm.ch](mailto:info@metrohm.ch)  
<http://www.metrohm.ch>

# **796 Titroprocessor**

---

Program version 5.796.0010

## **Instructions for use**

## Table of content

<b>1 Introduction</b>	<b>1</b>
<b>1.1 Range of applications</b>	<b>1</b>
<b>1.2 Application possibilities</b>	<b>1</b>
<b>1.3 Instrument description</b>	<b>3</b>
1.3.1 Model versions	3
1.3.2 Front view	3
1.3.3 Rear view	4
1.3.4 Peripheral device connections	4
1.3.5 Measuring interfaces / Measuring inputs	5
1.3.6 Data cards / Key cards	5
1.3.7 The built-in thermal printer	6
<b>1.4 The keyboard</b>	<b>7</b>
1.4.1 Function keys (softkeys)	7
1.4.2 Hotkeys	7
1.4.3 Action keys	8
1.4.4 Manual printing	8
1.4.5 Navigation and editing keys	8
1.4.6 HELP key	9
1.4.7 The GLP key	9
1.4.8 Special key abbreviations	9
<b>1.5 Dialog</b>	<b>11</b>
1.5.1 Dialog overview	11
1.5.2 The main page	11
1.5.3 The status window	12
1.5.4 The trace window	13
1.5.5 How to navigate	13
1.5.6 Field cursor	14
<b>1.6 How to edit</b>	<b>14</b>
1.6.1 Navigation in edit mode	15
<b>2 Installation</b>	<b>16</b>
<b>2.1 Instrument setup</b>	<b>16</b>
<b>2.2 Mains supply</b>	<b>16</b>
<b>2.3 Mains connection</b>	<b>17</b>
2.3.1 Fuses	17
2.3.2 Mains cable and mains connection	18
2.3.3 Setting up the thermal printer	18
<b>2.4 Data / key card handling (PC cards)</b>	<b>19</b>
<b>2.5 Safety information</b>	<b>21</b>
<b>2.6 Connections</b>	<b>22</b>
2.6.1 System components and peripheral devices	22
2.6.2 Dosing devices	23
2.6.3 External bus	24
2.6.4 Sample changers	25
2.6.5 Sensors / Electrodes	26
2.6.6 Connecting a balance	27
2.6.7 Connecting an external printer	29
2.6.8 Connecting a bar-code reader	30
2.6.9 Devices on the remote interface	31
2.6.10 LIMS connection	33

<b>3 Configuration</b>	<b>34</b>
<b>3.1 Basic settings</b>	<b>34</b>
<b>3.2 Configuration of sample changers</b>	<b>38</b>
3.2.1 Sample racks .....	39
3.2.2 Special beakers .....	42
3.2.3 Basic configuration of 717 Sample changer.....	43
<b>3.3 Interface configuration</b>	<b>44</b>
3.3.1 Setting the RS232 interfaces.....	45
3.3.2 Balances and printers .....	45
3.3.3 Data communication settings .....	45
3.3.4 Internal thermal printer .....	46
3.3.5 Initializing the RS232 interfaces .....	46
<b>3.4 Buret units</b>	<b>47</b>
3.4.1 Tubing definitions.....	48
3.4.2 700 Dosino, dosing units .....	49
3.4.3 685 Dosimat, exchange units .....	51
<b>4 Manual operation</b>	<b>53</b>
<b>4.1 Overview</b>	<b>53</b>
<b>4.2 Dosing devices</b>	<b>54</b>
4.2.1 Automatic reagent check.....	54
4.2.2 Dosing device functions .....	55
4.2.3 Manual dosing .....	56
<b>4.3 Sensors</b>	<b>57</b>
4.3.1 Automatic sensor check .....	57
4.3.2 Manual measurement .....	57
4.3.3 Calibration.....	58
<b>4.4 Sample changer</b>	<b>63</b>
4.4.1 Sample rack and lift functions.....	65
<b>4.5 Stirrer at measuring interface</b>	<b>66</b>
<b>4.6 Remote lines (Input / Output)</b>	<b>66</b>
<b>4.7 Print</b>	<b>67</b>
4.7.1 The printer menu.....	67
4.7.2 General reports .....	68
4.7.3 Determination reports .....	69
<b>5 Methods and determinations</b>	<b>71</b>
<b>5.1 General</b>	<b>71</b>
<b>5.2 Method editor</b>	<b>71</b>
5.2.1 Load method.....	72
5.2.2 Create new method .....	72
5.2.3 Softkeys and their functions .....	74
5.2.4 Determination report .....	75
<b>5.3 Determinations</b>	<b>80</b>
5.3.1 Carrying out a determination.....	80
5.3.2 Individual determinations .....	81
5.3.3 System variables .....	85
5.3.4 Determination files .....	85
5.3.5 Sample series .....	87
5.3.6 Course of a sample series .....	90

<b>6 Sample data and sample silo</b>	<b>92</b>
<b>6.1 Sample data entry</b>	<b>92</b>
6.1.1 Direct data transfer from balances	92
6.1.2 Bar-code reader	93
<b>6.2 Sample silo</b>	<b>93</b>
6.2.1 Sample silo configuration	96
6.2.2 Automatic data input and output	97
<b>7 Titration and measuring modes</b>	<b>99</b>
<b>7.1 General</b>	<b>99</b>
<b>7.2 DET Dynamic equivalence point titration</b>	<b>101</b>
7.2.1 Measuring mode	101
7.2.2 Reagent addition and measurement acceptance	101
7.2.3 Automatic equivalence point recognition	102
7.2.4 Fixed endpoints	102
7.2.5 Evaluation of pK and HNP values	102
<b>7.3 MET Monotonic equivalence point titration</b>	<b>104</b>
7.3.1 Measuring mode	104
7.3.2 Reagent addition and measurement acceptance	104
7.3.3 Automatic equivalence point recognition	105
7.3.4 Fixed endpoints	105
7.3.5 Evaluation of pK and HNP values	106
<b>7.4 SET Titration to a preset endpoint</b>	<b>107</b>
7.4.1 Measuring mode	107
7.4.2 Reagent addition	107
7.4.3 Measuring point list	108
7.4.4 Switch-off criteria at the endpoint	108
<b>7.5 SEC Endpoint conditioning</b>	<b>109</b>
7.5.1 Control of the conditioning mode	109
<b>7.6 KFT Karl Fischer titrations</b>	<b>111</b>
7.6.1 Measuring mode	111
7.6.2 Reagent addition	112
7.6.3 Measuring point list	112
7.6.4 Switch-off criteria at the endpoint	112
<b>7.7 KFC Karl Fischer conditioning</b>	<b>114</b>
7.7.1 Control of the conditioning mode	114
<b>7.8 MEAS Extended measuring functions</b>	<b>115</b>
7.8.1 Measuring modes	115
7.8.2 Standard measurement	115
7.8.3 Multiple measurement	116
<b>7.9 CAL Calibration of pH sensors</b>	<b>117</b>
<b>7.10 Calculations / Formulas</b>	<b>119</b>
7.10.1 System variables	121
7.10.2 Mathematical functions	122
<b>7.11 Reports</b>	<b>124</b>

<b>8 Command Reference</b>	<b>128</b>
<b>8.1 Titration modes</b>	<b>128</b>
<b>8.2 DET</b>	<b>129</b>
8.2.1 [ * Param ] Specific parameters for DET modes .....	131
8.2.2 User adjustments .....	137
8.2.3 EP recognition .....	139
8.2.4 Curve display .....	142
<b>8.3 MET</b>	<b>144</b>
8.3.1 [ * Param ] Specific parameters for MET modes .....	144
8.3.2 User adjustments .....	145
8.3.3 EP Recognition .....	146
8.3.4 Curve display .....	148
<b>8.4 SET</b>	<b>149</b>
8.4.1 Specific parameters for SET modes [ * Param ] .....	149
8.4.2 Custom Adjustments .....	152
8.4.3 Curve display with SET .....	154
<b>8.5 SEC</b>	<b>155</b>
8.5.1 Specific parameters for SEC modes [ * Param ] .....	156
<b>8.6 KFT</b>	<b>159</b>
8.6.1 Specific parameters for KFT modes [ * Param ] .....	159
8.6.2 Custom adjustments .....	165
8.6.3 Curve display with KFT .....	167
<b>8.7 KFC</b>	<b>168</b>
8.7.1 Specific parameters for KFC modes [ * Param ] .....	169
<b>8.8 MEAS</b>	<b>172</b>
8.8.1 Standard measurement .....	175
8.8.2 Multiple measurement .....	176
8.8.3 Curve display in MEAS modes .....	178
<b>8.9 CAL</b>	<b>179</b>
8.9.1 Simple calibration .....	179
8.9.2 Specific CAL* mode parameters [ * Param ] .....	181
8.9.3 Automatic calibration .....	182
<b>8.10 Sample changer commands</b>	<b>184</b>
8.10.1 Sample changer commands .....	184
<b>8.11 Dosing commands</b>	<b>192</b>
<b>8.12 CASE sequences</b>	<b>195</b>
<b>8.13 Communication functions</b>	<b>200</b>
8.13.1 Application mode of operation of CTRL and SCAN .....	200
8.13.2 Remote connections .....	200
8.13.3 RS 232 interfaces .....	203
8.13.4 Other communication commands .....	206
<b>8.14 Auxiliary commands</b>	<b>207</b>
<b>9 Results and statistics</b>	<b>213</b>
<b>9.1 Results page</b>	<b>213</b>
9.1.1 Statistics .....	216
<b>9.2 The &lt;RESULT&gt; key</b>	<b>218</b>

<b>10 Curves and re-evaluation</b>	<b>219</b>
<b>10.1 Single curves</b>	<b>219</b>
<b>10.2 Overlapping curves</b>	<b>222</b>
<b>10.3 Curve presentation</b>	<b>223</b>
<b>10.4 Re-evaluation</b>	<b>225</b>
<b>11 File manager</b>	<b>226</b>
<b>11.1 File list</b>	<b>226</b>
<b>11.2 File operations</b>	<b>227</b>
<b>11.3 Format data card</b>	<b>228</b>
<b>11.4 File backup</b>	<b>229</b>
<b>12 Troubleshooting</b>	<b>231</b>
<b>12.1 Error messages</b>	<b>231</b>
<b>12.2 Remedying storage errors</b>	<b>257</b>
12.2.1 Titroprocessor new start.....	257
12.2.2 RAM initialization (original initialization) .....	257
12.2.3 Clearing up memory errors in the data memory.....	257
<b>13 Appendix</b>	<b>260</b>
<b>13.1 Diagnosis</b>	<b>260</b>
<b>13.2 Common variables</b>	<b>270</b>
<b>13.3 Key cards and access control</b>	<b>272</b>
13.3.1 Configuration of the softkey bars.....	273
13.3.2 Status definitions .....	274
13.3.3 Creating a key card .....	276
13.3.4 Modifying an existing Access Control file.....	277
13.3.5 Monitoring a key card.....	277
<b>13.4 Remote operation / Key simulation</b>	<b>278</b>
<b>13.5 Validation / GLP</b>	<b>280</b>
13.5.1 Maintenance intervals.....	280
13.5.2 Sensor test .....	280
13.5.3 System validation.....	283
13.5.4 Preparing for a validation.....	284
<b>13.6 Technical specifications</b>	<b>288</b>
<b>13.7 Warranty and certificates</b>	<b>292</b>
13.7.1 Warranty.....	292
13.7.2 EC Declaration of conformity.....	293
13.7.3 Certificate of conformity and system validation .....	294
<b>13.8 Scope of delivery and accessories</b>	<b>295</b>
13.8.1 Titroprocessors .....	295
13.8.2 Options.....	296
<b>14 Index</b>	<b>299</b>

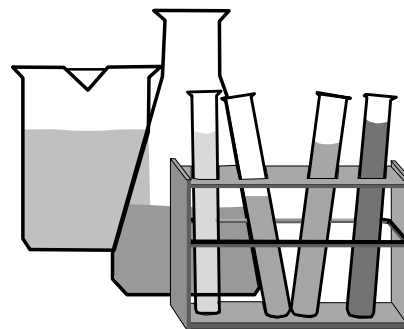

# 1 Introduction

---

## 1.1 Range of applications

The Metrohm 796 Titroprocessor is a very versatile analytical instrument. It has been designed exclusively for use in production plant and laboratories where it covers a wide range of applications. Together with the Metrohm 717 Sample changer it is very useful when processing large series of samples covering the whole field of titrations or for different measurement tasks.

Designed as a stand-alone precision titrator and the central unit of a comprehensive high-performance analytical system, it is predestined for mastering even the most complex applications with its various measuring inputs and dosing device interfaces. As a result of its extensive communications possibilities it does not just work with the wide range of Metrohm titrators, measuring instruments and dosing units, but can also control or be controlled by any other instruments equipped with a suitable communications interface. These capabilities mean that it is the right instrument for all automation tasks imaginable in a modern laboratory and it also offers the possibility of transferring the measuring data and results it produces to an existing laboratory information management system (LIMS).

Thanks to its extremely adaptable dialog structure and its versatile range of functions it is not only used by experts for working out complex methods, but also by routine analysts who wish to make their work easier with predefined methods and as simple a user interface as possible.

## 1.2 Application possibilities

The 796 Titroprocessor is completely designed for communication:

- Two RS 232C interfaces provide rapid communication with a balance, PC or LIMS. A parallel interface is available for use with an external printer.
- GLP-conform printout on the built-in thermal printer or, for versions without printer, on almost any commercially available printer.

- Up to twelve Dosinos or Dosimats can be addressed for titrating or dosing tasks.
- The 796 Titroprocessor has a connection for a bar-code reader for entering sample-specific data available in bar-code format.
- External instruments such as conductivity meters, dosing units, ion meters or any other peripheral devices can be operated both via the two serial RS 232C interfaces as well as via the "Remote" socket of the Titroprocessor and the "remote" socket(s) of the 717 Sample changer(s) (two 717 Sample changers can be connected at the same time). In the full version there are 36 output lines and 24 input lines available which can be individually set or monitored.
- A measuring group on the 796 Titroprocessor comprises two high-impedance measuring inputs for pH, redox or ISE sensors as well as an input for a separate reference electrode. These inputs can also serve as differential amplifier connections. A measuring input for polarized electrodes with a polarizer also forms a part of a measuring group, as does a measuring input for Pt 1000 or Pt 100 temperature sensors.  
The instrument versions with two measuring groups have twice the number of measuring connections mentioned above.

The run sequences for processing the individual samples can be freely defined within wide limits and can be stored as methods both in the internal memory of the Titroprocessor or separately on a separate data card and be transferred to other instruments of the same type.

Methods can include up to 99 command steps, of which up to five can be titration or measuring modes whose measuring data and results can be printed out directly, transferred to a LIMS system or stored. The measuring data produced can be reloaded at a later date and re-evaluated and re-calculated.

For complex automation tasks numerous functions for operating the 717 Sample changer are available. Two sample changers can be connected at the same time; however, in an automatic method run only one of them can be operated at once.

If series of samples are to be processed then special start and finish sequences (**OMOVE** and **CMOVE** sequences) can be defined, each of which is processed once only at the start and finish of a series of samples. This means that for a series of titrations the electrodes can be conditioned or calibrated with a specific series of buffers.

The 717 Sample changer itself offers all the functions necessary for a powerful automated system. Operation of the turntable, titrating heads, pumps and stirrers, even the 'Remote' interface of the sample changer can be carried out directly from the Titroprocessor.

Interchangeable standard sample racks are available for many sizes of sample vessels. Freely definable "special beaker" positions can be defined for each rack. These are used to locate the position of rinsing or conditioning beakers in the rack; these can be selected in any part-sequence.

Key cards enable every user of the 796 Titroprocessor to have his own working environment, which includes individual status settings, his own specific methods on the card and a customized user dialog, which means, only the dialog pages are accessible that he needs.

## 1.3 Instrument description

### 1.3.1 Model versions

---

The 796 Titroprocessor is available in four versions.

Versions with 1 measuring group:

- 2.796.0010** with complete accessories, without built-in printer, but with parallel interface for an external printer
- 2.796.0020** as 2.796.0010, but with built-in space-saving thermal printer (DIN A4), without additional parallel interface for a printer

Versions with 2 measuring groups:

- 2.796.0110** with complete accessories, without built-in printer, but with parallel interface for an external printer
- 2.796.0120** as 2.796.0110, but with built-in space-saving thermal printer (DIN A4), without additional parallel interface for a printer

### 1.3.2 Front view

---

Model 2.796.0010 of the 796 Titroprocessor without built-in printer.

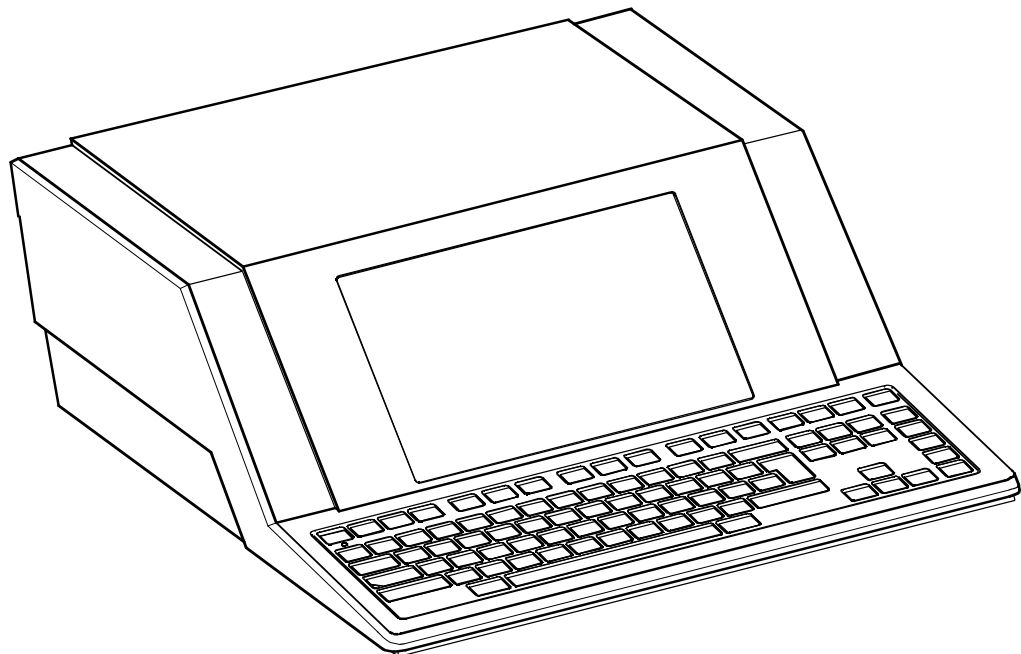

**1.3.3 Rear view**

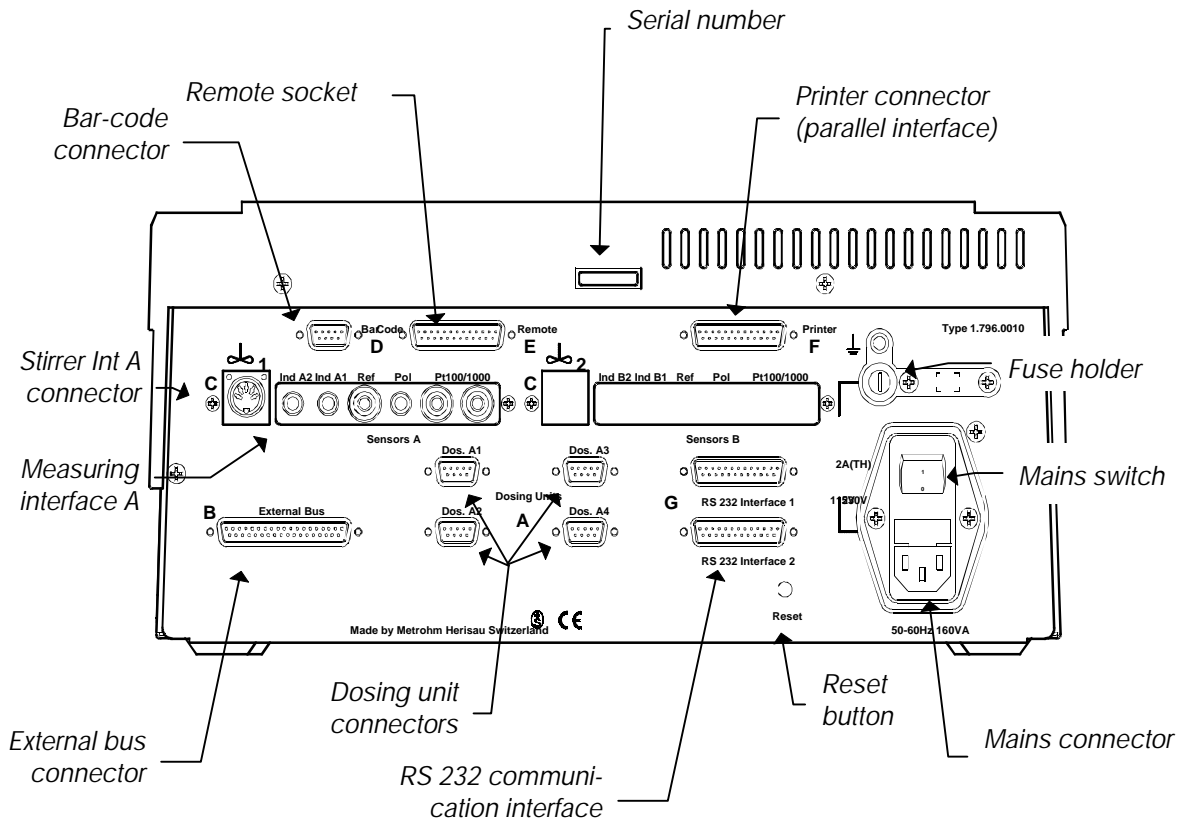

**1.3.4 Peripheral device connections**

Instrument	Interface designation	Label
Balance	RS 232 interface 1 or 2	<b>G</b>
Indicator electrodes	Sensors A or B (Ind A1, Ind A2, ..)	<b>C</b>
Indicator electrodes	Sensors A or B (Ref)	<b>C</b>
Temperature sensors	Sensors A or B (Pt100/1000)	<b>C</b>
Stirrer	Sensors A or B	<b>C</b>
Dosing devices	Dosing units	<b>A</b>
Sample changer	External bus	<b>B</b>
Dosing interface 729	External bus	<b>B</b>
Printer (Centronics)	Printer	<b>F</b>
Printer (serial)	RS 232 interface 1 or 2	<b>G</b>
Bar-code reader	Bar-code	<b>D</b>
Personal computer/LIMS	RS 232 interface 1 or 2	<b>G</b>
Auxiliary instruments	Remote	<b>E</b>

### 1.3.5 Measuring interfaces / Measuring inputs

The 796 Titroprocessor models 2.796.0110 and 2.796.0120 are equipped with 2 measuring interfaces (Sensors A and Sensors B). The diagram below shows where the sensors are to be connected to measuring interface A, which is found on all 796 Titroprocessor models.

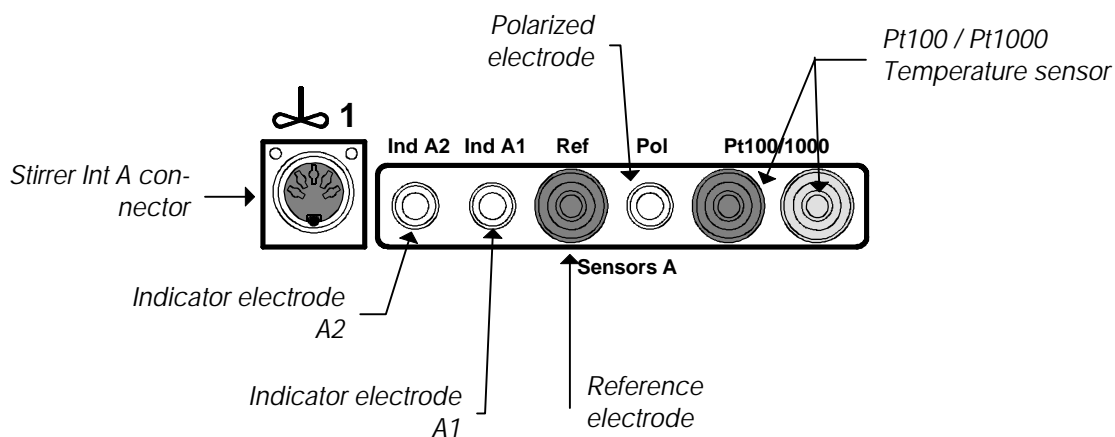

### 1.3.6 Data cards / Key cards

Data cards can be used to store methods or measuring data and to transfer them from one instrument to another. They are an excellent mobile storage medium.

Key cards enable every user to have his own specific methods and user interface settings.

Data cards or key cards are to be inserted in the memory card slot on the right hand side of the 796 Titroprocessor.

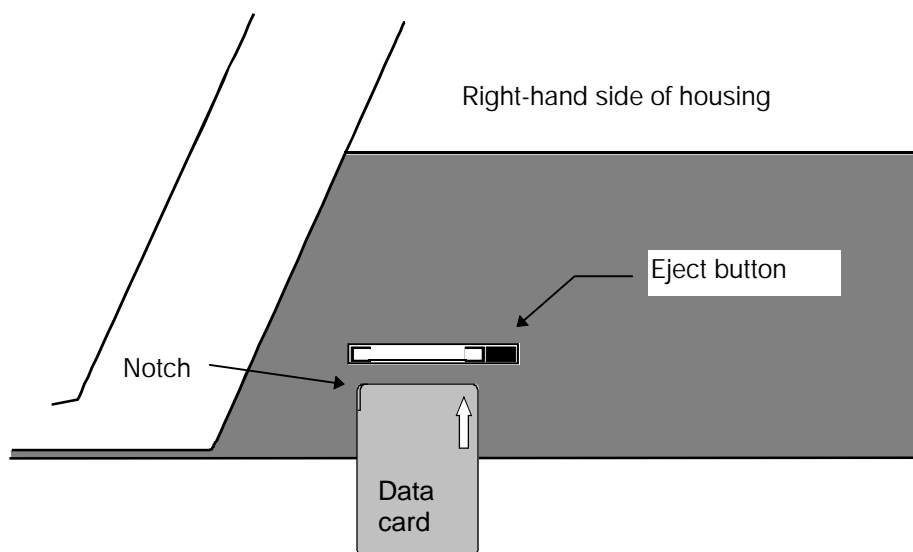

Attention must be paid to several points when handling data cards.

So-called PC cards which meet the Standard PCMCIA 2.x (68 Pins) / JEIDA 4.x can be used.

**Flash cards** can be read but not written on, e.g. the application card (Order. no. 6.6038.000) supplied with the Titroprocessor

**SRAM cards** can be read and written on.  
Capacity: 128 KB (Order no. 6.2245.010) to 2 MB (Order no. 6.2245.030).

#### **Card battery**

Data cards are battery-buffered storage media. The battery must be changed periodically in order to avoid data loss. Make a note of the expiry date of the battery which is given on the leaflet accompanying the card.

#### **Important:**

The expiry date of the battery refers to a storage temperature of 25°C. At higher storage temperatures the working life of the battery is shorter. Do not carry the card next to your body; do not store it near a heater or expose it to direct sunlight. The battery has to be replaced while the card is inserted in the instrument.

### **1.3.7 The built-in thermal printer**

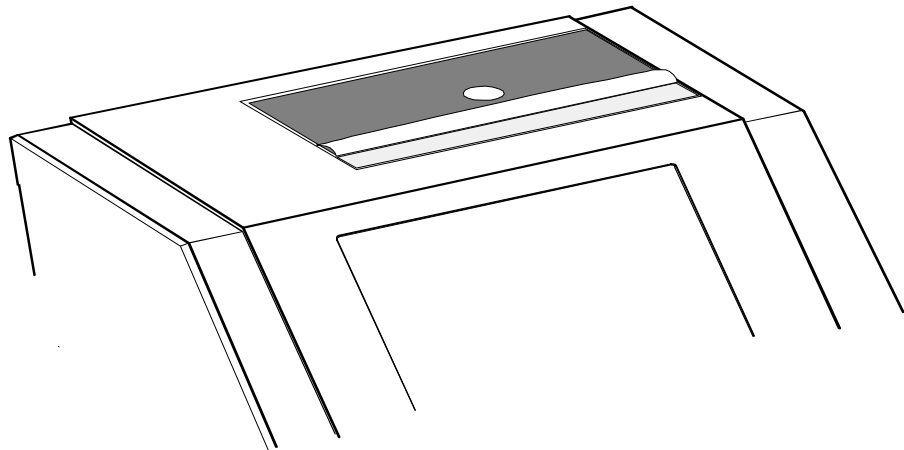

Titroprocessor models with built-in printer (2.796.0020 and 2.796.0120) can additionally have a second printer (or two) connected to an RS 232 interface. However, an additionally connected printer must have a serial interface as Titroprocessor models with built-in thermal printers do not have a parallel printer interface.

## 1.4 The keyboard

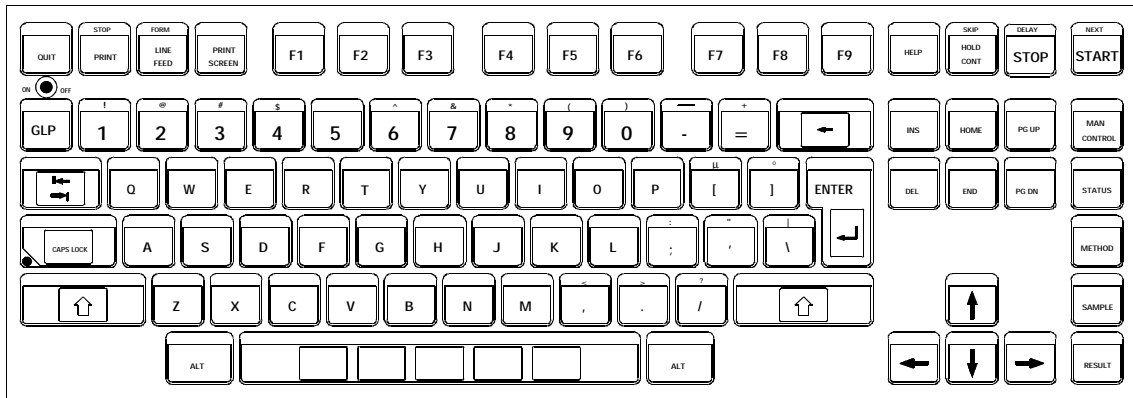

The PC-like keyboard allows comfortable editing and data input in method development and routine use.

### 1.4.1 Function keys (softkeys)

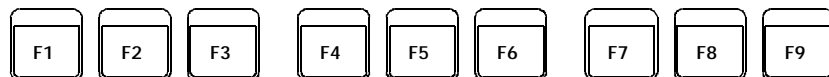

The blue function keys are used for navigation within the window-oriented operator dialog system. The function of these keys depends on the dialog page and the particular window. The softkey bar at the lower edge of the screen always shows the possible functions.

### 1.4.2 Hotkeys



The yellow hotkeys allow direct access to the most important functions or dialog pages of the 796. Hotkeys can be used anywhere in dialog except during the 'live' display of a curve while a determination is being carried out.

**MAN CONTROL** - opens the dialog page for manual operation

**STATUS** - displays the status information as shown on the main page

**METHOD** - opens the method selection window

**SAMPLE** - opens the sample input window or the sample silo

**RESULT** - opens a window which shows short result reports and statistics

### 1.4.3 Action keys



The action key have an immediate effect on the course of a method. The <START> key starts a method; the <STOP> key ends it. The <HOLD / CONT> key can be used to interrupt a method or to resume it.

If the <Shift> key is pressed at the same time as an action key the processing of a series of samples can be controlled directly (with Autostart 'on').

<Shift><START> (=NEXT) ends the processing of the current sample and starts processing the next sample in the series.

<Shift><STOP> (=DELAY) stops the sample series after the current sample has been processed.

<Shift><HOLD> (=SKIP) ends the execution of the current command and jumps to the next command line of the loaded method.

### 1.4.4 Manual printing

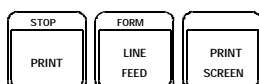

The built-in A4 thermal printer or any other connected printer can be operated manually with the yellow printer keys.

The <PRINT> key opens the printer menu where the type of report can be selected. Global reports and determination reports (if a determination report is present in the working menu) can be selected.

<Shift><PRINT> (= STOP PRINT) interrupts a printout immediately.

<LINE FEED> executes a line feed on the connected printer.

<Shift><LINE FEED> (= FORM FEED) executes a form feed on the connected printer.

<PRINT SCREEN> prints the current screen contents.

### 1.4.5 Navigation and editing keys



The <QUIT> key closes an editing field, a window or a dialog page and accepts previous parameter modifications. The dialog switches to the next higher level.

<INS> (= Insert) switches the insert mode on/off for editing an entry

<DEL> (= Delete) deletes the character to the right of the cursor position

<Shift><DEL> deletes a complete editing field.

<HOME> places the cursor on the first editing field of a dialog window (in navigation mode).

<END> places the cursor on the last sample silo line or command line (in method editor).

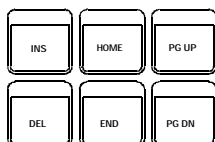

<**PG UP**> moves the field cursor in the sample silo or method editor up by one page.

<**PG DN**> moves the field cursor in the sample silo or method editor down by one page.

<**Cursor up**> moves the cursor up by one line.

<**Cursor down**> moves the cursor down by one line.

<**Cursor left**> moves the cursor one field (in navigation mode) or one character (in editing mode) to the left.

<**Cursor right**> moves the cursor one field (in navigation mode) or one character (in editing mode) to the right.

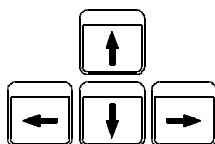

#### 1.4.6 HELP key



The <**HELP**> key opens a page with help texts which refer to the opened dialog page or window. In the editing mode it opens a help window for parameter input.

#### 1.4.7 The GLP key



The GLP key opens the dialog pages in which the basics functions for validating the Titroprocessor as an analytical system and for checking sensors (sensor test) can be carried out.

#### 1.4.8 Special key abbreviations

For certain functions special key combinations have been provided; these are listed below.

<b>ALT+-</b>	increase display contrast
<b>ALT+^-</b>	reduce display contrast
<b>ALT+A</b>	opens a dialog window to enter the access control page
<b>ALT+T</b>	transfer screen contents via the communications interface (printscreen to RS 232 interface)
<b>ALT+X</b>	transfer screen contents via the communications interface (with screen attributes line by line)
<b>ALT+U</b>	transfer screen contents via the communications interface (with screen attributes character by character)
<b>ALT+V</b>	transfer field contents of a selected editing field via the communications interface
<b>SHIFT+ALT+DEL</b>	Titration restart (mains on)

### Entry of special characters

In the editing mode any character contained in the ASCII character set can be entered. This is carried out by first entering the character ^ and then the **3-place** number of the required character. This is then displayed immediately.

Examples:

a	®	^224
b	®	^225
»	®	^247
»	®	^242
£	®	^243
±	®	^241

The complete table of the characters which are possible and their character numbers:

032	048 0	064 @	080 P	096 `	112 p	128 Ç	144 É	160 á	176 ☒	192 L	208 ⚭	224 a	240 °
033 !	049 1	065 A	081 Q	097 a	113 q	129 ü	145 æ	161 í	177 ☒	193 ⊥	209 ⚭	225 b	241 ±
034 "	050 2	066 B	082 R	098 b	114 r	130 é	146 Æ	162 ó	178 ☒	194 ⊥	210 ⚭	226 G	242 ∓
035 #	051 3	067 C	083 S	099 c	115 s	131 â	147 ô	163 ú	179	195 ⊥	211 ⚭	227 p	243 £
036 \$	052 4	068 D	084 T	100 d	116 t	132 ä	148 ö	164 ñ	180 †	196 –	212 ⚭	228 S	244 ó
037 %	053 5	069 E	085 U	101 e	117 u	133 à	149 ò	165 Ñ	181 †	197 †	213 ⚭	229 s	245 õ
038 &	054 6	070 F	086 V	102 f	118 v	134 á	150 û	166 ª	182 †	198 †	214 ⚭	230 m	246 ÷
039 '	055 7	071 G	087 W	103 g	119 w	135 ç	151 ù	167 °	183 ⚭	199 †	215 †	231 t	247 »
040 (	056 8	072 H	088 X	104 h	120 x	136 ê	152 ÿ	168 ¿	184 †	200 ⚭	216 †	232 F	248 °
041 )	057 9	073 I	089 Y	105 i	121 y	137 ë	153 Ö	169 ¸	185 †	201 ⚭	217 †	233 Q	249 ·
042 *	058 :	074 J	090 Z	106 j	122 z	138 è	154 Ü	170 ¸	186 †	202 ⚭	218 ⚭	234 W	250 ×
043 +	059 ;	075 K	091 [	107 k	123 {	139 ï	155 ç	171 ½	187 ⚭	203 ⚭	219 ☐	235 d	251 Ö
044 ,	060 <	076 L	092 \	108 l	124	140 î	156 £	172 ¼	188 ⚭	204 †	220 ■	236 ∞	252 º
045 -	061 =	077 M	093 ]	109 m	125 }	141 ï	157 ¥	173 ;	189 ⚭	205 =	221 ■	237 ⚭	253 ≈
046 .	062 >	078 N	094 ^	110 n	126 ~	142 Ä	158 Æ	174 «	190 †	206 †	222 ■	238 e	254 ■
047 /	063 ?	079 0	095 _	111 o	127 -	143 Å	159 f	175 »	191 †	207 ±	223 ■	239 Ç	255

## 1.5 Dialog

### 1.5.1 Dialog overview

The user dialog of the 796 Titroprocessor consists of 10 dialog pages, which contain hierarchically structured subwindows.

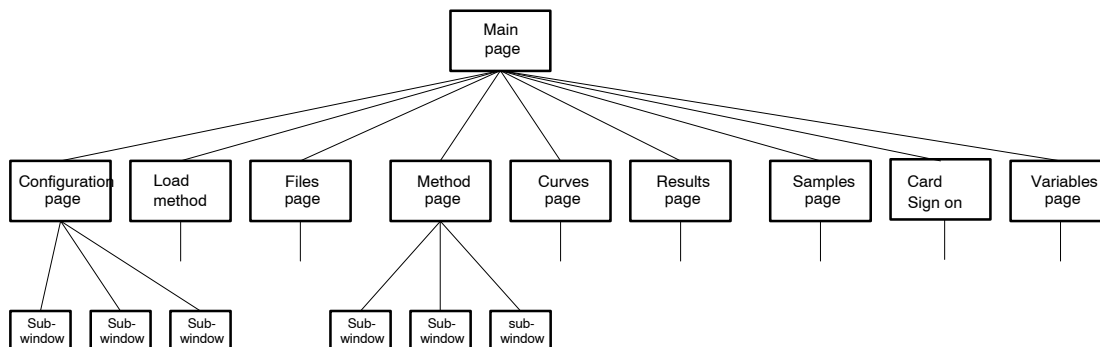

The main page of the 796 Titroprocessor is the entry to the user dialog. All other pages can be accessed by using the corresponding softkeys (<F1> to <F9>).

### 1.5.2 The main page

The main page in standard user level.

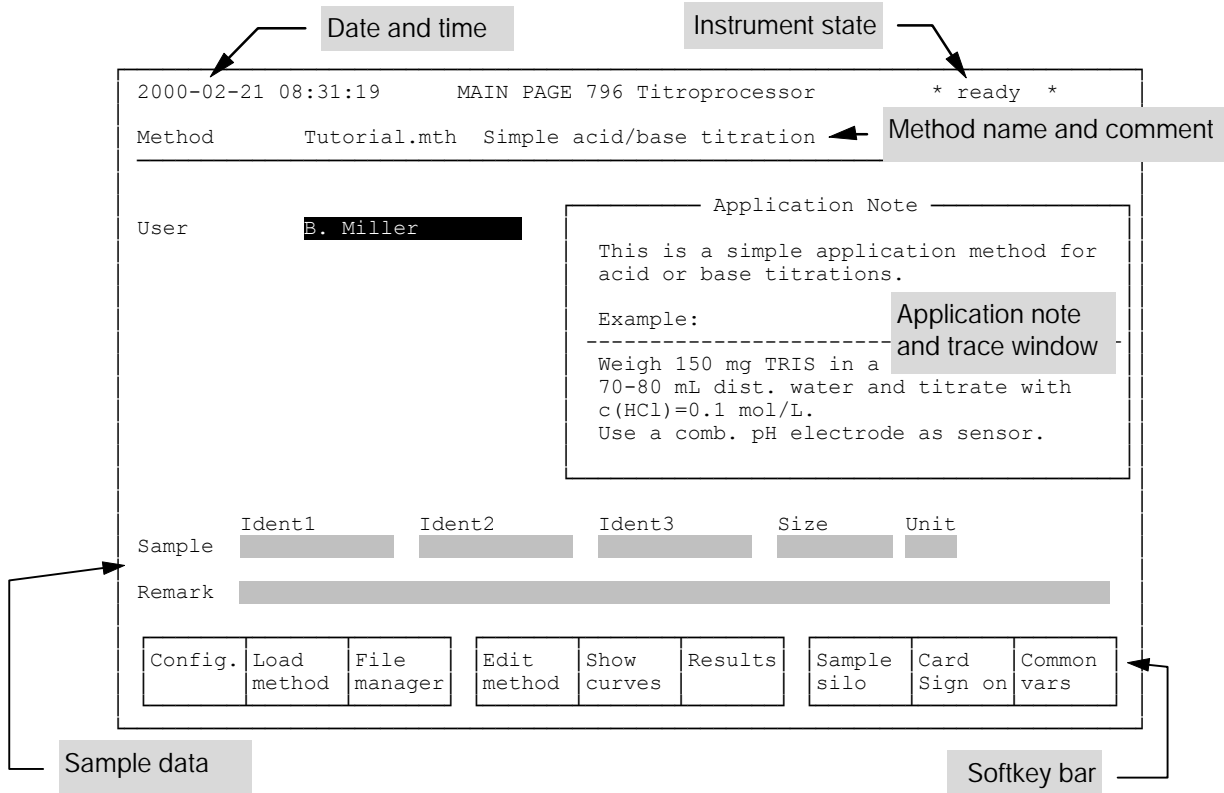

The main page in expert user level.

2000-02-02 09:24:13 MAIN PAGE Titroprocessor 796 \* ready \*

Method 3455.mth Chloride in Tap Water

User B. Miller

Run number 000

Statistics on 0 of 10

Auto save on 1.7 % free

Destination Data card

Determ.name

Auto start on 1 of 10

Silo on in# 12 out# 1

Changer 1 Sample pos. 1

Application note  
Chloride in Tap Water  
Sample preparation:  
Pipet accurately 100.00 mL of sample in a 150 mL beaker.  
Reagent: c(HNO3)=2 mol/L Dos A2  
Titrant: c(AgNO3)=0,01 mol/L Dos A1  
Sensor : Ag-Titrode 6.0430.100 Ind A1

Sample	Ident1	Ident2	Ident3	Size	Unit
001120/1		12	3455	100	mL

Remark

Sample data File manager Edit method Show curves Results Sample silo Devices ManCtrl Common vars.

The settings of the status area are the same as in the status window (<STATUS>key). See below for details.

### 1.5.3 The status window

In the standard user level the status settings are available only in the status window. The <STATUS> key on the keyboard will open the status window.

2000-02-10 14:04:05 MAIN PAGE 796 Titroprocessor \* ready \*

Method Acid.mth Acid titration c(HCl)=0.1 mol/L

Use **Status**

Run number 000 Determination name

Sample silo on Next sample in silo line 1  
Sample entry in silo line 1

Auto start on Current sample 0 of 9999

Statistics on Data records 0 of 2

Save determ. data on Destination Data card  
Free Memory 1.6 %

Sam Sample changer 1 First rack position 1

Rem QUIT

### 1.5.4 The trace window

During the course of a method the display window of the application note changes to a trace window, showing the state of the currently executed command. The display format depends on the current command or mode.

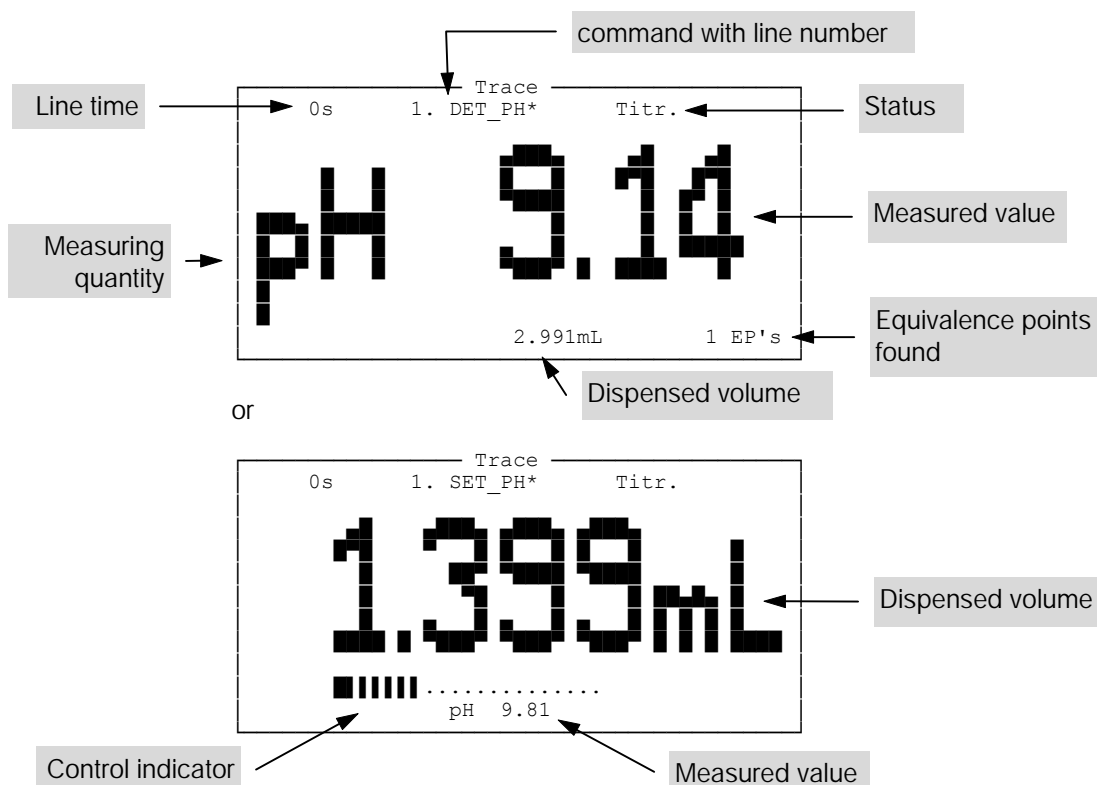

### 1.5.5 How to navigate

To navigate from page to page or from subwindow to subwindow you can use the blue function keys <F1> to <F9>. These function keys alter their meaning or functionality, depending on the dialog page or window that is shown on the screen. The function of the corresponding function key is always shown at the bottom of the screen. It is called the softkey bar. The function keys (<F1> to <F9>) are called **softkeys**.

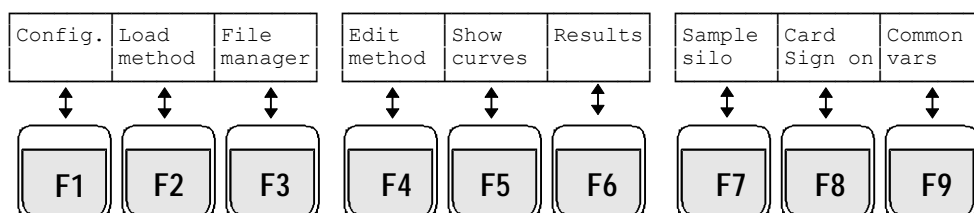

A dialog page or window can be left or closed by pressing the <QUIT> key. Any prior modifications of parameters will be accepted.

The shortcut keys of the rightmost key column on the keyboard allow direct access to some important dialog windows or features.

The shortcut keys are: <MAN CONTROL>, <STATUS>, <METHOD>, <SAMPLE>, <RESULT>.

### 1.5.6 Field cursor

To navigate on a page or in a dialog window you can use the cursor keys <←>, <→>, <↑> or <↓>. The position of the so called field cursor is indicated by the black field background of the edit field the cursor is pointing to. To navigate right or left within a line you can use the <TAB> key or the <Shift><TAB> key combination, respectively. The <HOME> key sets the field cursor to the first edit field of a page or dialog window.

## 1.6 How to edit

To edit an entry of an edit field just type in the new value or press the <SPACE> key. In most cases a picklist is shown, from which you can select a given value by using the cursor keys <↓> and <↑>. The selection must be confirmed with <ENTER> or the picklist may be closed by pressing the <QUIT> key. The field cursor will turn into a block cursor which indicates the edit mode.

The PC-like keyboard allows comfortable editing of text or numeric entries. To erase any character use the <DEL> (forward deletion) or the <BACKSPACE> key (<[ ← ]> backward deletion). The <INS> key switches the insert mode to the overwrite mode and vice versa.

In this mode a special softkey bar is shown.

Help on	Select	...	Cancel
entry		...	

- The **[Help on entry]** softkey may be used to open a window with a short explanation of the meaning or the content of the entry field to be edited. The entry range and one or more examples for entry values will be shown.
- The **[Select]** softkey opens the picklist of the selected entry field. If no picklist is available, the [Select] softkey is displayed in gray letters to indicate that its function is not available.
- The **[Cancel]** softkey rejects any modifications and resets the former field content. The edit mode will be canceled as well.

Modifications of field contents are to be confirmed with the <ENTER> or the <QUIT> key. The latter will terminate the edit mode.

**Tip:**

If the edit mode (entry on the configuration page, or press the <INS>key) is set to 'overwrite', you can simply type in the first letter or the first two letters of an entry item and press <ENTER> to change the content of an entry field with a selector list. If this entry can be uniquely assigned to an item of the selector list, it will be automatically completed.

**Example:**

To change the destination memory of data files for use with the auto save function, set the field cursor to the destination field on the Titroprocessor's main page. Type 'd' then and press the <ENTER>key. The entry of the destination field will be set automatically to 'Data card'.

This is the quickest way to modify entry fields .

---

**1.6.1 Navigation in edit mode**

---

In edit mode the cursor keys <←> and <→> allow the navigation within an entry field. To access other fields in the same line use the <TAB> key or the <Shift><TAB> key combination, respectively. The cursor keys <↓> and <↑> allow vertical navigation.

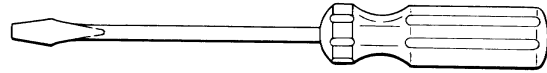

## 2 Installation

### 2.1 Instrument setup

#### Packaging

The 796 Titroprocessor is supplied together with the specially packed accessories in packaging containing shock-absorbing foam which provides excellent protection. Please store this special packaging as it guarantees damage-free transport of the instrument.

#### Checks

Please check immediately on receipt whether the shipment is complete and undamaged (compare with delivery note and list of accessories on page 290). If transport damage is established see section **13.7 Warranty and certificates** (p. 292).

#### Location

Place the 796 Titroprocessor in a convenient working position in the laboratory; this should be vibration-free and not exposed to corrosive atmospheres or contamination by chemicals.

### 2.2 Mains supply



**Follow the instructions given below for connection to the mains supply. If the instrument is operated with the mains voltage incorrectly set and/or the wrong mains fuse there could be a danger of fire!**

#### Setting the mains voltage

Before switching on the 796 Titroprocessor for the first time check that the mains voltage set on the instrument (can be seen in the mains voltage selector) corresponds to the local mains voltage. The mains voltage selector is located on the rear panel of the instrument: please refer to following page.

If the mains voltage is incorrectly set then it must be set correctly by sliding the mains voltage selector with the help of a screwdriver:

 230V: 220V ... 240 V  $\pm$  10%

 115V: 100V ... 120 V  $\pm$  10%

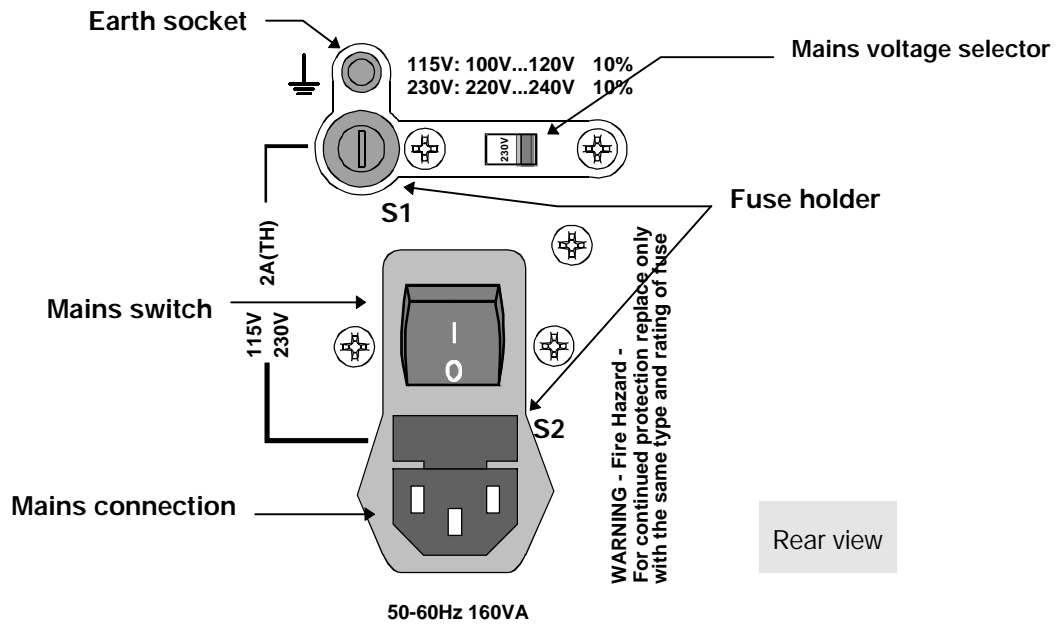

## 2.3 Mains connection

### 2.3.1 Fuses

Two fuses **S1** and **S2** are built into the 796 Titroprocessor as standard; both are type 2 ATH (2 A, slow-blow, with high switching capacity, Metrohm order no. U.600.0107).



**Make sure that the instrument is never operated with any different type of fuse as otherwise there is a fire hazard!**

To change blown fuses proceed as follows:

#### Exchange fuse **S1** (zero conductor, 2 ATH)

- Remove mains cable from mains connector.
- Use a screwdriver to turn fuse holder **S1** to the left until it can be pulled out.
- Pull out the fuse holder, remove the blown fuse and replace it with a spare fuse (2 ATH).
- Insert the fuse holder in the instrument, press it down with a screwdriver and then turn it to the right to fix it in position.

#### Exchange fuse **S2** (phase, 2 ATH)

- Remove mains cable from mains connector.
- Use a screwdriver to push fuse holder **S2** upwards until it can be pulled out.
- Pull out the fuse holder, remove the blown fuse and replace it with a spare fuse (2 ATH).
- Insert the fuse holder in the instrument and push until it clicks into place.

### 2.3.2 Mains cable and mains connection

The instrument is supplied with one of three types of cable:

- 6.2122.020 with plug SEV 12 (Switzerland, ...)
- 6.2122.040 with plug CEE(7), VII (Germany, ...)
- 6.2133.070 with plug NEMA 5-15 (USA, ...)

which has three leads and is fitted with a plug with an earthing pin. If a different plug has to be fitted then the yellow/green lead (IEC standard) must be connected to the earth (protection class 1). If no earthed socket is available then a proper earth connection must be made via the earthing socket of the instrument.



**Any break in the earthing lead, whether inside or outside the instrument, can cause the instrument to become a hazard!**

Insert the mains cable into the mains connector of the 796 Titroprocessor.

### 2.3.3 Setting up the thermal printer

**Insert paper** (only for the built-in printer)

The thermal printer of the Titroprocessors (models 2.796.0010 and 2.796.0110) is supplied without inserted paper. The thermal paper 6.2237.040 included with the accessories (roll approx. 40 m  $\cong$  130 A4 pages) is inserted into the printer as follows:

#### Preparations

- Switch on 796 Titroprocessor.
- Lift up the printer cover.
- Make sure that the roll of thermal paper 6.2237.040 has a straight edge; if necessary, carefully tear off the paper at the first perforation.
- Remove any scraps of paper or dust from the paper storage compartment. Check the new paper roll for scraps, too.

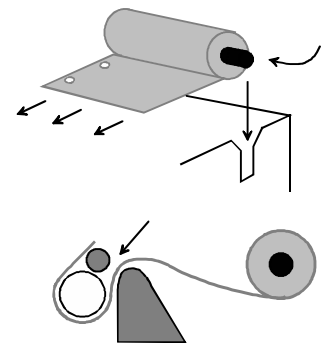

#### Insertion

- Insert paper spool 6.2241.020 in thermal paper roll 6.2237.040.
- Place the roll of paper with the paper spool in the two recesses at the sides of the printer so that the paper leaves the roll from the rear and the file hole margin is on the left-hand side when seen from the front.
- Carefully insert the straight-edged paper manually into the paper guide slot to the limit stop and hold it there.

#### Paper transport

- Press the two keys <Shift> and <FORM/LINE FEED>. The paper will be fed in automatically and transported to the correct position.
- Close the cover of the paper storage compartment.

## 2.4 Data / key card handling (PC cards)

The 796 Titroprocessor can write data onto SRAM storage cards and read this data in at a later date. It is not possible to use FLASH cards others than the one delivered with the instrument. The following SRAM cards can be used as storage or key cards:

- 6.2245.030 Metrohm Data card (capacity 2 MB)
- 6.2245.010 Metrohm Data card (capacity 128 kB)
- Commercial SRAM cards of any capacity (up to 4 MB) with the hardware format JEIDA 4.0 (68 pin) as well as PCMCIA cards based on them



**Because of different file systems PCMCIA cards cannot be used at the same time for the 796 Titroprocessor and PCs.**

When handling data cards with the 796 Titroprocessor the following points are important:

### SRAM card preparation

The following preparations are necessary before data cards (or key cards) are used for the first time:

- New SRAM cards are supplied with a separately included battery. This should be inserted in the memory card according to the accompanying description.
- Data cards can only be inserted in the instrument in the position shown below. The included label should be attached to the top of the data card.

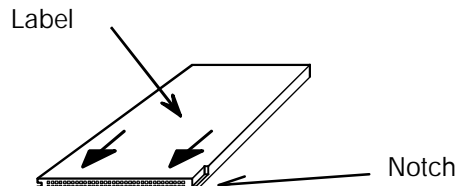

- The SRAM card battery has a limited lifetime; this is given in the accompanying leaflet. In order to avoid accidental loss of data, the date when the battery is due to be exchanged should be written on the data card label.
- Before data can be stored on the SRAM card it must be formatted. Proceed as follows:
  - Insert card in the 796 Titroprocessor (see above drawing).
  - Select file manager with the softkey **[File manager]** on the main page. Change the memory area with the softkey **[Change storage]**, select 'data card' with the cursor keys and press **<ENTER>**.
  - If an unformatted SRAM card has been inserted a system window appears on the display. Enter **<f>** to format the card.
  - A query about the card name is then made. A name with max. 20 characters can be entered; this will now be displayed in the file manager whenever the card is inserted. When the entry has been completed the data card is formatted with **<Enter>**.

### Data card insertion and removal

- The data card can only be inserted in den 796 Titroprocessor in one particular position (see above illustration). It must be pressed firmly into the slot provided until the eject button fully protrudes.
- A data card inserted into the Titroprocessor slot can be ejected by pressing the eject button and then removed manually.



---

**SRAM cards are sensitive to electrostatic charges. Make sure that you are earthed each time you insert or remove a data card (e.g. by previously touching the earthed green 796 Titroprocessor housing).**

---

### Changing the battery

- The battery of the SRAM card has a limited working life which is given in the leaflet accompanying the card. Please note that the working life of batteries depends on the storage temperature. Data cards or spare batteries should therefore be stored as cool as possible (in any case below 25°C).
- The date for the next battery change should be marked on the data card label (see above). In order to avoid accidental data loss the battery should be replaced by this date at the latest.
- Insert the data card in the 796 Titroprocessor.



---

**The battery must only be exchanged with the card inserted in the instrument, as otherwise the data stored on the card will be lost. The card is powered by the Titroprocessor while the battery is being changed.**

---

- Change the battery according to the accompanying description.
- Mark the data card label with the new date for the next battery change (see under "data card preparation" above).

## 2.5 Safety information

If failure or malfunctioning occurs during operation of the 796 Titroprocessor we recommend that the diagnostic functions are first used to try and determine the cause (see page 260). If this does not help to rectify the failure or if the cause of the malfunction cannot be remedied then please consult the service department of your local Metrohm agency.

If opening the instrument cannot be avoided then the following safety measures must be strictly observed:



---

**The instrument must be disconnected from all electricity supplies before opening. Make sure the mains plug has been pulled out.**

---

Only in exceptional cases should the instrument be opened while it is switched on. As this exposes current-conducting components it should only be undertaken by an expert who is familiar with the associated dangers.

Electronic components are sensitive to static electricity and can be destroyed by discharges. Before touching any components inside the instrument both the person and his tools should be earthed by grasping an earthed object (e.g. the instrument housing or a radiator) in order to eliminate any static electricity.

If it becomes apparent that the instrument can no longer be operated safely then it should not be used at all.

## 2.6 Connections

### 2.6.1 System components and peripheral devices

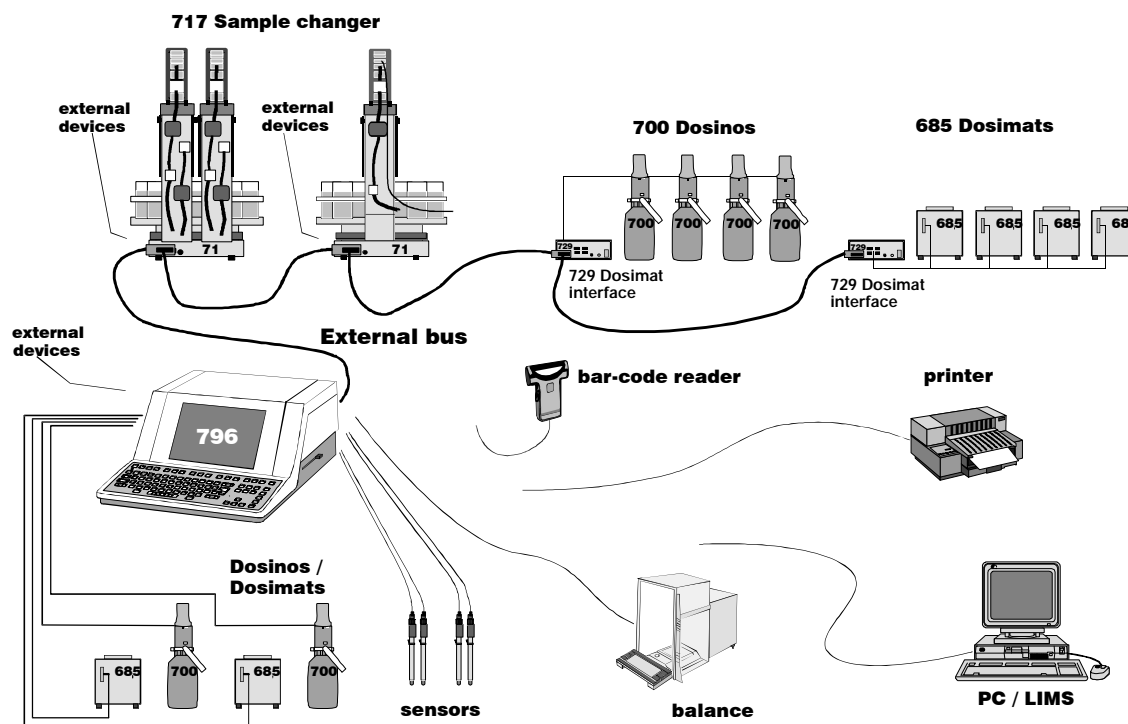

The 796 Titroprocessor can be extended to provide an automated and comprehensive analytical system.

Metrohm cables should always be used to connect Metrohm instruments and accessories, as only these guarantee interference-free data transmission. For instruments from other manufacturers please observe the manufacturer's recommendations.

The Titroprocessor offers the following connections:

- 4 dosing devices, further (up to 8) dosing devices can be connected via the '**External bus**' (see below).
- 2 measuring groups (models 2.796.0010 and 2.796.0020 have only 1 measuring group) each with measuring inputs for 2 indicator electrodes (or combined measuring electrodes), 1 reference electrode, 1 polarizable electrode (voltammetry/ampereometry, KF titrations), 1 Pt100/Pt1000 temperature sensor connection, 1 stirrer connection
- 1 '**External bus**' connection for up to two 717 Sample changers and/or up to 8 dosing devices, to be connected via Dosimat interfaces 729 (4 dosing devices per interface)
- 2 serial RS 232 connections (25-pole) for balance, printer or personal computer (LIMS, automatic data storage or remote control of the 796 Titroprocessor)

- 1 parallel printer connection for any external printer (only for models 2.796.0010 and 2.796.110)
- 1 bar-code reader connection (9-pole) for entering sample data
- 1 remote connector (25-pole) with 8 input and 8 output leads for controlling external peripheral devices (e.g. Relay Box, KF Oven, etc.). Each 717 Sample changer has a further remote connector (25-pole) with 8 input and 14 output leads which can be directly addressed from the 796 Titroprocessor.

### 2.6.2 Dosing devices

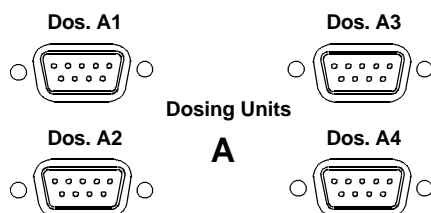

Up to 4 dosing devices can be directly connected to the rear panel of the Titroprocessor. For connecting a 685 Dosimat you need a 6.2134.000 cable. Dosing devices are recognized by the addresses A1 to A4.

Two different types of Metrohm dosing device are available for selection:

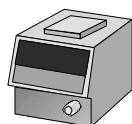

- 685 Dosimat, with the normal exchange units.
- 700 Dosino, with 710 dosing unit

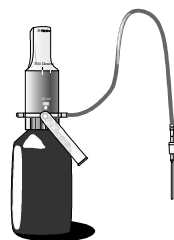

Dosinos are operated by the 796 Titroprocessor in the standard configuration, i.e. the reagent is drawn in from the bottle via Dosino port 2 (filling port) and added via port 1 (dosing port). The port occupancy cannot be changed when a Dosino is used with the 796 Titroprocessor.

685 Dosimats and 700 Dosinos can be combined as required.



**Switch off the 796 Titroprocessor before connecting an instrument to it. When it is switched on again the Titroprocessor automatically recognizes the new instrument.**

If more than four dosing devices are to be connected then the additional dosing devices should be connected via 729 Dosimat interface to the 'External bus' (for connections see sample changer below).

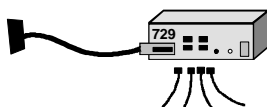

Plug the 729 Dosimat interface directly into the 'External bus' socket of the Titroprocessor or, if installed, into the corresponding socket of the 717 Sample changer.

### 2.6.3 External bus

The external bus allows external instruments to be controlled by the 796 Titroprocessor. Sample changers and dosing devices such as the 685 Dosimat or the 700 Dosino can communicate bi-directionally with the Titroprocessor (=bus master).

External devices must be connected with EBus cables according to the following scheme:

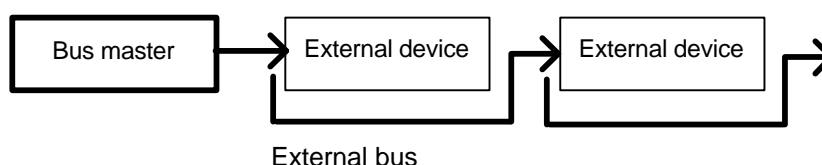

Each external instrument is identified by an EBus address. When the Titroprocessor is switched on they are automatically identified. An EBus address must be set for each external device (1...9, A...F; 0 stands for the bus master).



#### Address selector

The corresponding EBus address can be set with a screwdriver. The EBus address selector is usually located on the rear panel of the external device.

External device	EBus address	Corresponding peripherals
Sample changer 1	<b>1</b>	1...2 lifts, 0...4 pumps, 1...4 stirrers
Sample changer 2	<b>2</b>	1...2 lifts, 0...4 pumps, 1...4 stirrers
Dosimat interface 1	<b>1</b>	1...4 Dosimats (B1...B4)
Dosimat interface 2	<b>2</b>	1...4 Dosimats (C1...C4)

Devices such as sample changers which consume a lot of current should be connected in the first position of the EBus chain. This is particularly important if the relevant sample changer is equipped with more than one pump. The 729 Dosimat interfaces should be connected to the 717 Sample changer.

The 796 Titroprocessor and the Dosimat interfaces must be connected to the same earth. A line distributor should be used to supply all devices on the external bus.

**The 796 Titroprocessor must be switched off before a peripheral device is connected.**

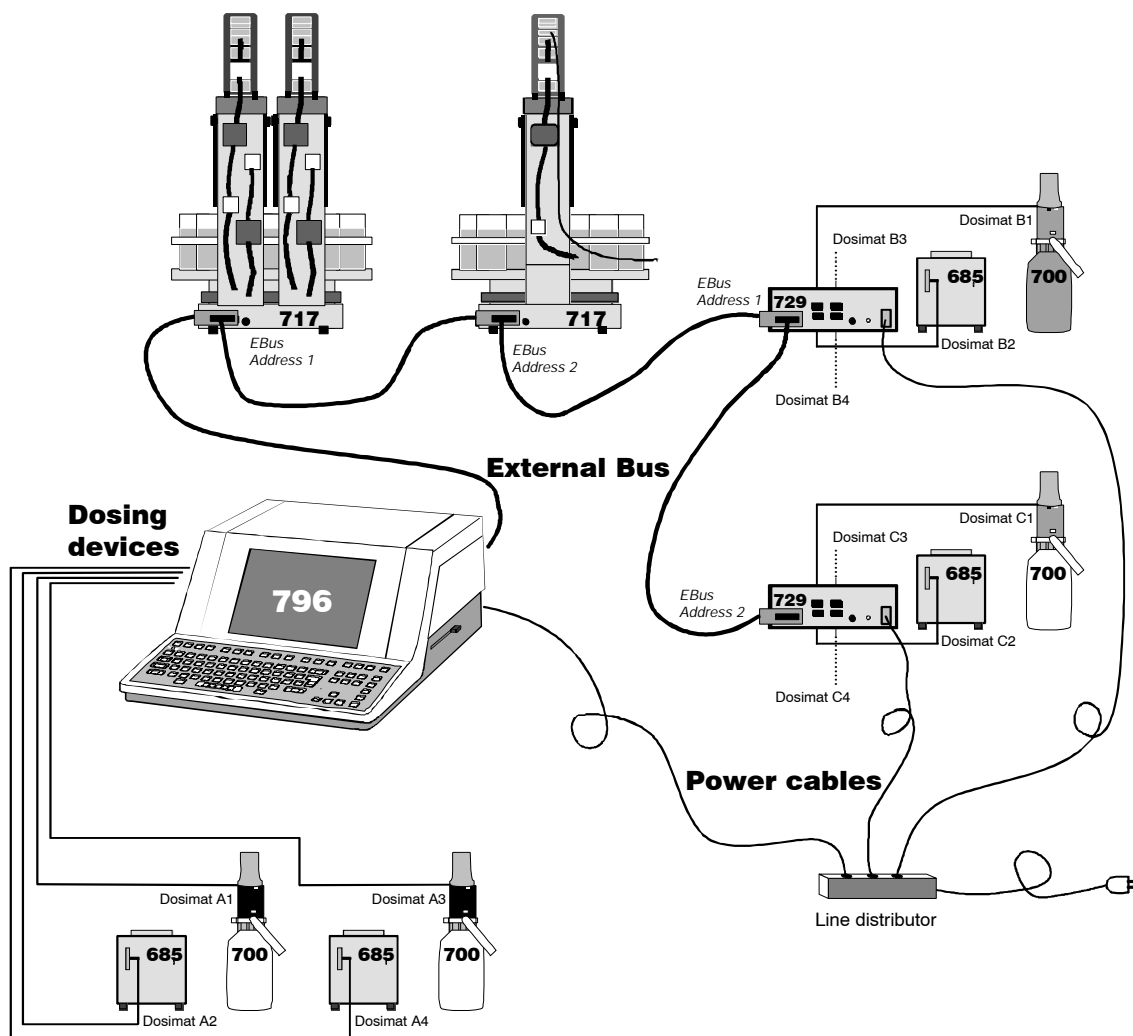

### 2.6.4 Sample changers

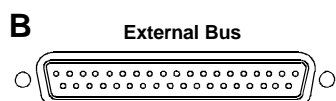

One or two 717 Sample changers can be connected to the 'external bus' sockets of the 796 Titroprocessor. Take care that the address selector disk is set correctly (see above). Please connect up larger systems according to the above diagram.

Two 717 Sample changers can be connected at the same time; however, they cannot be used simultaneously in one automatic method. It is possible to change the active sample changer within a method (see command '**CHANGER**').

Manual operation of a sample changer while the other sample changer is busy carrying out a method is possible and does not present any problems.

### 2.6.5 Sensors / Electrodes

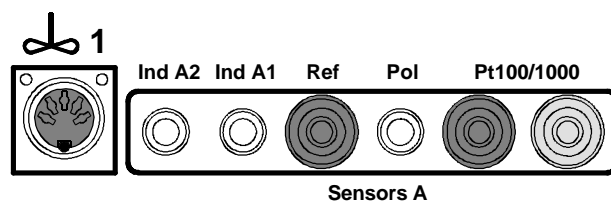

Titroprocessor models 2.796.0110 and 2.796.0120 are supplied with two built-in measuring interfaces (Sensors A and Sensors B). The models 2.796.0010 and 2.796.0020 only have one measuring interface (Sensors A) but can be extended to two measuring interfaces at a later date with **upgrade set 6.5855.000**.

#### The different measuring inputs of a measuring interface:

- **Ind A1, A2**  
Input for indicator or measuring electrodes (single and combined electrodes) for potentiometric determinations.  
It is possible to carry out a manual measurement at one measuring input while the second input is carrying out a titration.
- **Ref**  
Separate reference electrode input. If combined electrodes are used this electrode input is not required.
- **Pol**  
Connection for polarized electrodes for amperometric and voltametric determinations (measuring modes Upol or Ipol).
- **Pt100/1000**  
Inputs for Pt100 or Pt1000 temperature sensors (also used for electrodes with built-in Pt100 or Pt1000 sensors).
- **Stirrer connection**  
Stirrer power supply (12 V, 250 mA) for operation without sample changer. Can be used with 728 Magnetic stirrer, 722 Rod stirrer and 727 and 703 Titration stands.

The measuring inputs Ref, Ind A1 and Ind A2 (or B1, B2) can be used together as a differential amplification switch for differential potentiometry. This is recommended for measurements or titrations in low-conductivity media (e.g. organic solvents).

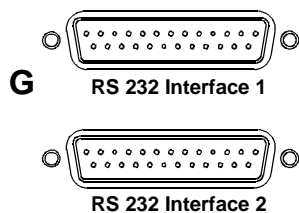
**2.6.6 Connecting a balance**

The following balances can be connected to an RS 232 interface of the 796 Titroprocessor:

Balance	Cable
<b>Sartorius</b> MP8, MC1	6.2134.060
<b>Mettler</b> AB, AG, PR	LC-RS25, supplied with balance
<b>Mettler</b> AM, PM	from Mettler: ME 33995: green wire to pin 2, brown to pin 3, white to pin 7, yellow to pin 20 of the 25-pole plug + 6.2125.010 25-pole/9-pole adapter
<b>Mettler</b> interface 016	cable supplied with interface 016: red wire to pin 3, white wire to pin 7 of the 25-pole plug + 6.2125.010 25-pole/9-pole adapter
<b>Mettler</b> interface 011 or 012	6.2125.020 + 6.2125.010
<b>Mettler</b> AT	from Mettler: ME 33995: green wire to pin 2, brown to pin 3, white to pin 7, yellow to pin 20 of the 25-pole plug + 6.2125.010 25-pole/9-pole adapter
<b>AND</b> types ER-60, 120, 180, 182 types FR-200, 300 types FX-200, 300, 320 with RS 232 interface (OP-03)	6.2125.020 + 6.2125.010
<b>Precisa</b> , balances with RS 232C interface	6.2125.080 + 6.2125.010

The type of balance must be entered in the Titroprocessor on the configuration page under [**Interfaces**].

The data transmitted from the balance are directly interpreted by the 796 Titroprocessor within the permitted input range for the sample weight including sign and decimal point. The units given in the following table are also accepted:

Gram	<b>g</b>
Milligram	<b>mg</b>
Kilogram	<b>kg</b>
Pieces	<b>pcs</b>
Pieces	<b>PC</b>
Carat	<b>ct</b>
Pound	<b>lb</b>
Ounce	<b>oz</b>
Troy ounce	<b>ozt</b>
Grain	<b>GN</b>
Pennyweight	<b>dwt</b>

Units which are not listed and which are transmitted directly after the weight cannot be interpreted and will therefore be rejected.

Any control characters which the balance may transmit will cause the Titroprocessor to produce an error message. Switch off all your balance's automatic status messages when it is connected to the 796 Titroprocessor.

With the aid of a special input unit supplied by the balance manufacturer it is possible to enter the sample identification and method from the balance as well as the sample weight. This is done by preselecting the addresses of the identification and method on the input unit.

<b>Balance</b>	<b>Method</b>	<b>Ident1</b>	<b>Ident2</b>	<b>Ident3</b>
Sartorius	METH or 27	ID.1 or 26	ID.2 or 24	C-20 or 23
Mettler (AT)	D (Mthd)	C (ID#1)	B (ID#2)	A (c20)

**2.6.7 Connecting an external printer**

There are various ways of connecting an external printer to the 796 Titro-processor.

**Parallel printer interface** (only for models 2.796.0010 and 2.796.0110)

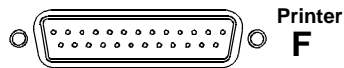

Commercial printers for PCs (e.g. inkjet printers from Hewlett-Packard, Epson, Canon) can be connected without any problems to the '**Printer**' connection on the rear panel of the Titroprocessor with the cable supplied by the manufacturer.



**So-called GDI printers (e.g. HP Deskjet 620 or 820) are specially designed for use under MS-Windows® and can only be used under MS-Windows®. They cannot be used with the 796 Titroprocessor.**

**Printer on the serial RS 232 interface**

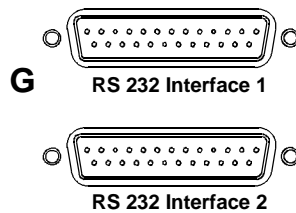

It is also possible to connect an external printer to models 2.796.0020 and 2.626.120. Printers which have their own serial RS 232 interface can be connected directly to '**RS 232 Interface 1**' or '**RS 232 Interface 2**' with the aid of cable 6.2125.050 (e.g. Epson LX-300).

If necessary commercial printers with a parallel Centronics interface can be connected to one of the RS 232 interfaces of the Titroprocessor by means of serial/parallel converter SP 1000 (2.145.0300). In addition a serial 6.2125.020 connection cable is required. Depending on the type of printer a 9V mains adapter for the SP 1000 converter and possibly an extension cable between the converter and printer may be required. Please consult your local Metrohm distributor.

The following table shows the settings and cables needed to connect printers to one of the *serial interfaces*.

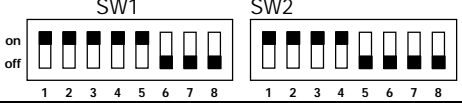
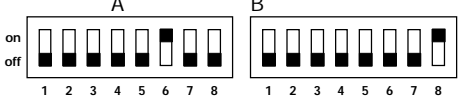
Printer	Cable	RS232 settings	Printer settings
IBM Proprinter or compatibles	6.2125.050	Baud rate: 9600 Data bit: 8 Stop bit: 1 Parity: none Handshake: HWshort Printer: IBM Propr.	see printer manual
Epson with 6-pole round plug	6.2125.040	Baud rate: 9600 Data bit: 8 Stop bit: 1 Parity: none Handshake: HWshort Printer: Epson 80x60	DIP switch settings: 
Epson LX-300	6.2125.050	Baud rate: 9600 Data bit: 8 Stop bit: 1 Parity: none Handshake: HWshort Printer: Epson 80x60	see printer manual
HP Deskjet with serial interface	6.2125.050 or adapter cable 25-pol.neg. / 9-pol.pos. (e.g. HP C2933A)	Baud rate: 9600 Data bit: 8 Stop bit: 1 Parity: none Handshake: HWshort Printer: HP Deskjet	DIP switch settings: 
HP Laserjet with serial interface (and compatibles)	6.2125.050 or adapter cable 25-pol. neg. / 9-pol. pos. (e.g. HP C2933A)	Baud rate: 9600 Data bit: 8 Stop bit: 1 Parity: none Handshake: HWshort Printer: HP Deskjet	see printer manual
HP Deskjet/ Laserjet with parallel interface	6.2125.020 + serial/ parallel converter 2.145.0300	Baud rate: 9600 Data bit: 8 Stop bit: 1 Parity: none Handshake: HWshort Printer: HP Deskjet	see printer manual

### 2.6.8 Connecting a bar-code reader



A bar-code reader can be connected to the bar-code reader socket on the rear panel of the Titroprocessor. It can be used as a data input and transmits the coded data directly to the keyboard buffer of the Titroprocessor. The plug occupancy and the transmission parameters of the reader must correspond with the Metrohm specifications, see page 289. Please consult your local Metrohm distributor to obtain a list of recommended bar-code readers.

**2.6.9 Devices on the remote interface**

External peripheral devices such as pH meters, pumps, etc. can be controlled via the remote interface (25-pole socket) of the Titroprocessor. Each 717 Sample changer also has a remote socket which can be controlled via the 'External bus'.

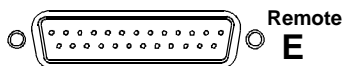

8 lines are available for signal output (Output 0-7). The remote socket of the 717 Sample changer has 14 output lines available (Output 0-13).

For receiving signals (e.g. the "ready" signal from a Metrohm instrument) there are 8 lines available (Input 0-7).

The pin occupancy of the remote socket:

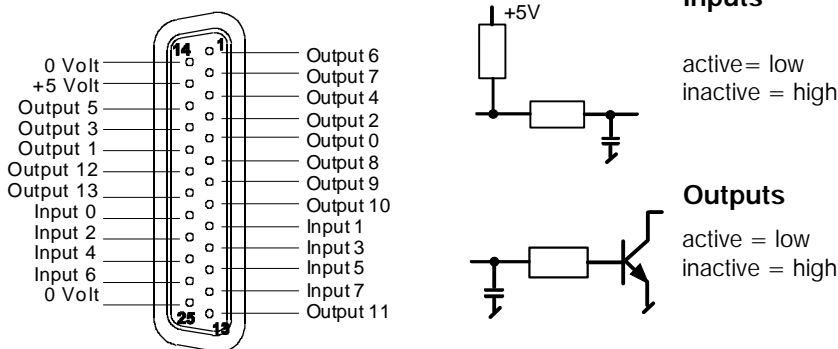

The control lines of the 796 Titroprocessor are purely signal leads (TTL-level) and should not be misused for supplying devices. Remote connections can be used with specially assembled cables to solve complex connection problems in automated systems.

Connection of Metrohm instruments is solved in the following manner with **6.2141.020 Standard remote cable**

796	Metrohm instrument	796	Metrohm instrument	
Output 0	-----	Input 0	-----	Output 0
Output 1	-----	Input 1	-----	Output 1
Output 2	-----	Input 2	-----	Output 2
Output 3	-----	Input 3	-----	Output 3
Output 4	-----	Input 4	-----	Output 4
Output 5	-----	Input 5	-----	Output 5
Output 6	-----	Input 6	-----	Output 6
Output 7	-----	Input 7	-----	Output 7
Output 8	-----	Pin 6		
Output 9	-----	Pin 7		
Output 10	-----	Pin 8		
Output 11	-----	Pin 13		
Output 12	-----	Pin 19		
Output 13	-----	Pin 20		

Output lines 8...13 can only be used with the 717 Sample changer, but are not used as input lines for Metrohm instruments. They are laid 1:1 on Pin 6...8,13,19...20.

For the individual model series of Metrohm instruments different connection cables are available with which the specific functions of the particular instrument can be addressed. On request Metrohm can supply special cables in accordance with the customer's wishes with which complex connections can be made (even to instruments from other manufacturers).

The 8 or 14 output lines of the remote socket can be set at will both in manual operation and during a method run with the "**CONTROL**" command (**CTRL\_RM**) by setting an 8 or 14-place bit pattern in which each bit is allocated to an output line. The output lines can also be set manually.

Output	13	12	11	10	9	8	7	6	5	4	3	2	1	0
Bit	13	12	11	10	9	8	7	6	5	4	3	2	1	0

(Bits are always numbered from right to left)

Example:     **CTRL\_RM**     **Remote A**     **Signal**     **\*\*\*\*\*1**  
 sets output line 0 to active (=set) which, for example, if a Metrohm Ion meter is connected would have the effect of a start command.

0 = inactive (high)  
 1 = active (low)  
 \* = no change

It is recommended that non-relevant output lines are masked with an asterisk (\*) so that the status of the line is not changed.

The 8 input lines of the remote socket can be scanned during a method with the "**Scan**" command (**SCAN\_RM**). Execution of the method is stopped until the pre-determined bit pattern coincides with the effective condition of the input lines (e.g. the status of the ready line, for querying the end of a determination from a Metrohm instrument). This is done by setting an 8-place bit pattern in which each bit is allocated to an input line. When they coincide the method will be continued with the next command. In manual operation the status display of all input lines can be scanned.

Input	7	6	5	4	3	2	1	0
Bit	7	6	5	4	3	2	1	0

(Bits are always numbered from right to left)

Example:     **SCAN\_RM**     **Remote A**     **Signal**     **\*\*\*\*\*1**  
 waits for an active input line 0 (1=set). This line will be set by e.g. a Metrohm instrument when a determination has been finished and a start signal can again be accepted.

0 = inactive (high)  
 1 = active (low)  
 \* = arbitrary

Input lines which are not of interest or for which no defined status can be predicted should also be masked with an asterisk (\*) here.

With a suitable multiple cable (with special wiring) even several instruments can be controlled simultaneously via the remote lines. The bit patterns for the **CTRL\_RM** and **SCAN\_RM** commands can be combined for this purpose.

### **2.6.10 LIMS connection**

---

An RS 232 interface can be used for connecting the 796 Titroprocessor to a LIMS system (**L**aboratory **I**nformation **M**anagement **S**ystem). 6.2125.060 Connection cable (25-pole to 25-pole) or 6.2125.010 is connected to RS 232 interface socket 1 or 2. The serial connection **COM1** or **COM2** on the Personal Computer must be used.

During the configuration of the interfaces (softkeys [**Config.**] [**Interfaces**]) take care that no other instrument (balance or printer) has been defined for the same connection. Under '**Communication Int.**' enter the corresponding RS 232 interface (1 or 2). Under '**Commun. mode**' enter '**LIMS**'. The remaining data transmission parameters must be set the same for both the PC and the Titroprocessor. Reports cannot just be printed out but can also be sent directly to the LIMS system.

# 3 Configuration

In order to guarantee problem-free work with the 796 Titroprocessor it is essential that the basic settings of all instrument components are configured according to your requirements.

## 3.1 Basic settings

By pressing the softkey **[Config.]** the basic configuration can be accessed from the main page.

Configuration (Program version 5.796.0010)

Dialog in <b>english</b>	Date <b>2000-02-04</b>
	Time <b>16:05:52</b>
LCD contrast <b>100</b>	Standard data file name <b>DATA</b>
Screen save <b>30 min</b>	File name type <b>&lt;Ident1&gt;###</b>
Error beep <b>on</b>	File comment type <b>Ident1,2+Meth+Remark</b>
Edit beep <b>on</b>	Power on PREP warning <b>on</b>
Edit mode <b>insert</b>	Remote terminal mode <b>off</b>
User level <b>Standard</b>	File transfer protocol <b>Metrohm(Bkup)</b>
Key card <b>no</b>	
Monitoring <b>off</b>	

QUIT

Device header	File	Access control	Sample changer	Inter-faces	Config. idents.	Tubings	>>	>>
---------------	------	----------------	----------------	-------------	-----------------	---------	----	----

The basic settings for the Titroprocessor 796 can be configured on this dialog page. The softkeys allow access to the configuration of further components.

- Dialog in**                      Dialog language. English, German, French and Spanish are available. After changing the dialog language the instrument should be switched off and then back on again.
- LCD contrast**                  Contrast can be selected in 250 steps. The contrast can also be set with the key combinations **<ALT><↑>** and **<ALT><↓>**.
- Screen save**                    Delay period for switching the screen off. If no key on the Titroprocessor is pressed within the set period then the background illumination of the LCD screen will be automatically switched off (for its own care). Pressing a key switches it on again.
- Error beep**                      Acoustic error message signal on/off
- Edit beep**                       Acoustic editing error message signal on/off
- Edit mode**                      Switches between overwrite/insert mode during data input

<b>User level</b>	Switches between standard and expert user level. <b>Standard</b> = use of key cards possible, customizable status settings, modifyable softkey bars  <b>Expert</b> = no key cards, 726 Titroprocessor-compatible dialog
<b>Key card</b>	<b>yes:</b> Access to the 796 Titroprocessor is only possible by use of a key card. Status settings and the configuration of the softkey sets are loaded from the access control configuration file of the key card.
<b>Monitoring</b>	<b>on:</b> The presence of a key card inserted is monitored frequently during a sample series. If a key card is missing after the finish of a determination series, an automatic user sign-off will occur.
<b>Date</b>	System date in format YYYY-MM-DD
<b>Time</b>	System time in format hh:mm:ss

#### Settings for determination files:

Each determination is automatically allocated a file name . There are various ways of creating this file name. Combinations of determination time/date, run number, sample identification and/or a particular standard text can be defined.

<b>Standard</b>															
<b>data file name</b>	Standard text, which can be used for automatically naming determination files. The file names are produced automatically under file name type during the determination according to the given mask.														
<b>file name type</b>	Mask for the automatic creation of file names for determination files. The selection list:														
	<table border="0"> <tr> <td><b>&lt;stand.&gt;###.dtm</b></td> <td>standard + run number</td> </tr> <tr> <td><b>&lt;standard&gt;.dtm</b></td> <td>only standard file name</td> </tr> <tr> <td><b>&lt;standard&gt;###</b></td> <td>standard + run number</td> </tr> <tr> <td><b>&lt;YYMMDDhh&gt;###</b></td> <td>date + run number</td> </tr> <tr> <td><b>&lt;ident1&gt;###</b></td> <td>sample identification + run number</td> </tr> <tr> <td><b>&lt;ident1&gt;.dtm</b></td> <td>only sample identification</td> </tr> <tr> <td><b>YYMMDDhh.mms</b></td> <td>date + time</td> </tr> </table>	<b>&lt;stand.&gt;###.dtm</b>	standard + run number	<b>&lt;standard&gt;.dtm</b>	only standard file name	<b>&lt;standard&gt;###</b>	standard + run number	<b>&lt;YYMMDDhh&gt;###</b>	date + run number	<b>&lt;ident1&gt;###</b>	sample identification + run number	<b>&lt;ident1&gt;.dtm</b>	only sample identification	<b>YYMMDDhh.mms</b>	date + time
<b>&lt;stand.&gt;###.dtm</b>	standard + run number														
<b>&lt;standard&gt;.dtm</b>	only standard file name														
<b>&lt;standard&gt;###</b>	standard + run number														
<b>&lt;YYMMDDhh&gt;###</b>	date + run number														
<b>&lt;ident1&gt;###</b>	sample identification + run number														
<b>&lt;ident1&gt;.dtm</b>	only sample identification														
<b>YYMMDDhh.mms</b>	date + time														

#### Example:

Standard file name = 'DATA'  
Run number = 005

**<stand.>###.dtm**  
→ produces the file name:       **DATA005.dtm**

The subsequent determinations in the same series of samples are given the file names **DATA006.dtm**, **DATA007.dtm** etc.

Please note that only the combination *Date + Time* guarantees that a particular file name can never be used twice.

**File  
comment type**

Mask for automatic creation of file comments for determination files.

The selection list:

<b>off</b>	no file comment
<b>Remark</b>	only sample remark
<b>Ident1+Meth</b>	sample identification + method name
<b>Ident1,2+Meth</b>	sample identification + method name
<b>Ident1,2,3+Meth</b>	sample identification + method name
<b>Ident1+Remark</b>	sample ident. + remark
<b>Ident1,2+Remark</b>	etc.
<b>Ident1,2,3+Remark</b>	...
<b>Ident1+Meth+Remark</b>	...
<b>Ident1,2+Meth+Remark</b>	...

The scheme for the automatic creation of file comments corresponds to that for automatic file name creation, see above.

**Power on  
PREP warning**

If this warning is switched on this means that immediately after the Titroprocessor is switched on a display window appears with a reminder that a dosing device must be prepared before the start of a sample series, i.e. the buret must be rinsed with reagent.

**Remote  
terminal mode**

This mode can be switched on by the remote control of the Titroprocessor 796 via the RS232 interface. It has the effect of sending the screen contents with all character attributes as ANSI control sequences via the RS232 interface as soon as an alteration to the screen contents occurs.

**File transfer  
protocol**

For data storage of determination or other files on a personal computer two different data transfer protocols are available. If Metrodata 796 backup software is used then '**Metrohm (Bkup)**' should be selected, otherwise select '**Kermit**'. This latter requires that a PC terminal program is used which supports this data transfer protocol.

## Softkeys

---

<b>[Device header]</b>	opens the dialog window for the entry of an instrument-specific, four-line header, which will be printed out before the report of a determination.
<b>[File]</b>	opens the file dialog window for storing and loading configuration files. It is recommended that all the instrument configuration settings are stored on a data card in this way. In a configuration file all the subordinate areas on the configuration page are stored in addition to the common variables. The rack tables of special racks are not stored and, if necessary, must be separately loaded with the help of rack files, see page 41.
	In this way it is possible to reconstruct the whole configuration of the Titroprocessor at a later date, or to install the same settings on different instruments.
	When loading a configuration file the individual configuration areas can be selected for individual take-over.
<b>[Access control]</b>	opens, after the corresponding password has been entered, the configuration page for definition of the access control. Individual keys on the keyboard as well as most of the softkeys on the dialog pages can be blocked or blinded out. Details can be found on page 272ff.
<b>[Interfaces]</b>	opens the configuration window of the interfaces. The transfer parameters of the RS232 interfaces can be entered here and the definition of balances and printer set. Details can be found on page 44.
<b>[Config idents.]</b>	opens the configuration window of the sample identification fields. The titles of the fields (Ident1...3) can be freely selected. The field types determine whether the contents of the sample identification fields are to be interpreted as text or as numerical values. In the latter case the sample identifiers (system variables <b>ID1...3</b> ) can be used in calculation formula, see page 119ff. If the sample silo is switched on then the definitions of the sample identification fields in the sample silo are valid. See also page 97.
<b>[Buret unit]</b>	opens the configuration window of the buret units. In order to use the dosing functions preparation ( <b>PREP</b> ) and empty ( <b>EMPTY</b> ) in an optimal way it is necessary to define buret units in which the tubing

dimensions and other settings for this function are fixed. Details can be found on page 46ff.

[>> >>] switches to the second softkey bar.

[Service  
diagn.]

opens the dialog window for instrument diagnosis . It is possible to test the various instrument components and functions in order to check the functional capabilities of the Titroprocessor 796. Instrument diagnosis should be carried out with great care as improper handling could result in important data being deleted. Certain of the diagnostic functions are reserved for our service technicians.

Instrument diagnosis is described on page 260ff. It is recommended that all the files in the internal memory as well as the configuration settings (see softkey [File]) are stored on data cards or on a PC before the diagnosis function is carried out.

[>> >>] switches to the second softkey bar.

### 3.2 Configuration of sample changers

In order to guarantee reliable sample changer operation it is important that the settings of the connected sample changer 717 and the sample racks used are configured correctly.

By pressing the softkey [Config.] and then the softkey [Sample changer] the configuration of the sample changer can be accessed from the main page.

Configuration (Program version 5.796.0012)

Configuration: Sample changer

	#	Name	Beakers	Special positions				Type	Code
				Work	Shift	Rinse	Spec.		
Fehl	1	12*250mL	12	0 mm	0 mm	0 mm	0 mm	M12-0	000001
Edit	2	16*150mL	16	0 mm	0 mm	0 mm	0 mm	M16-0	000010
Edit	3	24*75mL	24	0 mm	0 mm	0 mm	0 mm	M24-0	001000
	6	12*150mL	12	0 mm	0 mm	0 mm	0 mm	M12-0	100000
	5	14*8oz	14	0 mm	0 mm	0 mm	0 mm	M14-0	000101
	4	14*200mL	14	0 mm	0 mm	0 mm	0 mm	M14-0	000011
	7	19*100mL	19	0 mm	0 mm	0 mm	0 mm	M19-0	001001
	8			0 mm	0 mm	0 mm	0 mm		
	9			0 mm	0 mm	0 mm	0 mm		
	10			0 mm	0 mm	0 mm	0 mm		
	11			0 mm	0 mm	0 mm	0 mm		
	12			0 mm	0 mm	0 mm	0 mm		
	13			0 mm	0 mm	0 mm	0 mm		
	14			0 mm	0 mm	0 mm	0 mm		
	15			0 mm	0 mm	0 mm	0 mm		
	16			0 mm	0 mm	0 mm	0 mm		

QUIT IT

Delete type	Rack File	
-------------	-----------	--

Special beakers	Changer 1	Changer 2
-----------------	-----------	-----------

Delete line	Delete all	Check code
-------------	------------	------------

### 3.2.1 Sample racks

A sample rack is a turntable which accepts sample beakers and which is placed on the sample changer. As different sizes of sample beaker may be required for different applications it is possible to use various types of sample rack which can be easily exchanged for one another. Depending on the diameter of the sample vessel, different racks provide space for different numbers of samples. Multi-row sample racks can accept a larger number of samples if a 759 Swing head is used. Metrohm supplies the following predefined standard types of sample rack, among others:

Type	No. of samples	Type of sample vessel	Magnet code predefined	Order number
M12-0	12 <sup>*)</sup>	250 ml Metrohm sample beaker	000001	6.2041.310
M12-0	12 <sup>*)</sup>	150 ml beaker or 200 ml disposable beaker (Euro)	100000	6.2041.360
M14-0	14	200 ml disposable beaker (Euro)	000011	6.2041.370
M14-0	14	8 oz disposable beaker (US)	000101	6.2041.380
M16-0	16	150 ml beaker	000010	6.2041.320
M24-0	24 <sup>*)</sup>	75 ml Metrohm sample beaker	001000	6.2041.340
M48-1	48 <sup>**)</sup>	75 ml Metrohm sample beaker	010000	6.2041.350

<sup>\*)</sup> simultaneous sample processing at two sample changer towers possible.

<sup>\*\*)</sup> two-row rack for use with a 759 swing head .

On request further racks defined by the operator can be supplied and their rack tables loaded into the Titroprocessor. Irregular arrangements of the beaker positions are also possible.

Each individual sample rack can be unambiguously identified by means of the magnet code. Magnetic rods, located on the base of the rack, can be combined to form a binary 6-place code. This means that the sample changer can identify the rack automatically. This is possible when the sample rack is positioned with the first beaker position under Lift 1. When a rack is changed the **<MAN CONTROL>** key should first be activated and then the sample changer brought to the initial position with the softkeys **[Sample changer][Reset]**. In this way the definite recognition of the rack and thus the correct positioning of the beakers is possible. When a series of samples is started the sample changer automatically brings the rack to the initial position first so that a clear recognition of the particular rack is always guaranteed.

The standard racks supplied by Metrohm are already provided with a predefined magnet code for each type of rack. If several racks of the same type are to be used then the magnetic rods can be arranged differently to enable the unambiguous identification of a particular sample rack, should this be required.

The format of the magnet code (example):

000001    i.e. only one magnet is inserted in the outer right-hand position  
or bit 0  
000101    i.e. two magnets are inserted, bits 0 and 2

63 different combinations are possible. Code 000000 stands for 'no code defined'.

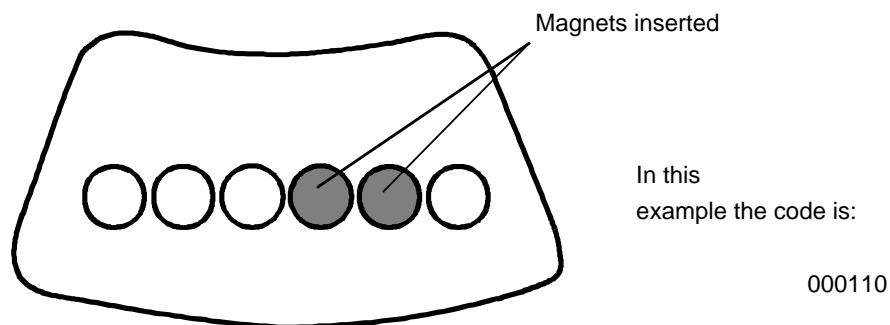

In order to allocate a certain sample rack to a particular application it is possible to define particular properties or characteristics for up to 16 racks. This makes sense when an application requires a particular size of vessel, size of sample series or a particular procedure in order for the method to be carried out.

The following characteristics can be defined for each rack:

**Rack name** The **rack name** is used for the unambiguous identification of a rack. The command '**Changer**' in the method run can be used to stipulate the use of a particular rack. The automatic rack recognition ensures that the use of an incorrect sample rack is recognized and that the operator is informed of this.

**Beakers** The number of beaker positions is obtained from the rack table. It does not need to be entered.

#### Special positions

For the lift stations of a changer tower particular „stopping points“, i.e. predefined lift positions can be laid down:

**Work** The **work position** is used for fixing the position of the titrating head (lift), in which e.g. a titration can be carried out. Depending on the height of the sample beaker the ideal setting can always be selected for each sample rack. In manual operation this work position can be moved to directly by means of the <PG DN>key.

**Shift** The **shift position** is used to fix the position of the titrating head (lift) in which the sample rack can be rotated. If the lift is not at or is above the shift position then the sample rack cannot be rotated. This is a safety measure as damage to the sensors caused by rotary movement of the rack is practically ruled out. A precondition is the correct setting of the shift position. In manual operation this shift position can be moved to directly with the <PG UP>key.

**Rinse** The **rinsing position** is used to fix the position of the titrating head (lift) at which the sensors can be rinsed at the titrating head.

<b>Spec.</b>	The <b>special position</b> is a further special position which can be defined for each lift. It can be used individually in a method run.
<b>Type</b>	The <b>rack type</b> is used for the assignment of an internal rack table in the instrument in which the positions of the sample beakers are defined on the rack in tenths of degrees (0-3599) of the complete rotary angle. Operator-defined special racks can be ordered from Metrohm. Their rack tables could for example be loaded from a data card, see softkey [ <b>Rack File</b> ]. The input fields for this column have a selection list (press space bar), in which the rack types stored in the instrument are listed. Newly added special rack types are included in it automatically.
<b>Code</b>	The <b>rack code</b> is used for automatic rack recognition. In the configuration of the rack it must be guaranteed that this 6-place binary code is identical with the magnet code set on the rack. Rack codes can be altered. They should only be allocated to one particular rack. The use of the predefined codes which are standard on the racks supplied by Metrohm should be avoided.

---

### Softkeys

<b>[Delete type]</b>	deletes the special rack type which has been selected with the cursor from the list of stored rack tables. The rack types preset as standards cannot be deleted.
<b>[Rack File]</b>	opens the file dialog window for loading a rack file (*.rck) which contains the position table of a special rack. The storage area from which the file is loaded can be selected in the entry field ' <b>Storage</b> '. After the loading process the name of the new rack type appears in the selection list of the entry field ' <b>Type</b> '.
<b>[Special beakers]</b>	opens the dialog window for entering one of the eight possible special beakers of the selected rack. The corresponding rack must first be selected with the cursor before the softkey is activated.
<b>[Changer 1]</b>	opens the dialog window for the definition of the basic settings of the 1st sample changer.
<b>[Changer 2]</b>	opens the dialog window for the definition of the 2nd sample changer.
<b>[Delete line]</b>	deletes the selected line or rack definition.

<b>[Delete all]</b>	deletes all rack definitions.
<b>[Check code]</b>	carries out a short test to check whether a rack code has been allocated more than once. If this is the case then a corresponding error message will be displayed.

### 3.2.2 Special beakers

Special beakers are the reserved beaker positions of a sample rack. Up to 8 special beakers can be defined per rack. In a method run they can be placed in front of a tower for particular operations without interrupting hindering the sample series. Special beakers can be used for rinsing the electrode in a sequence of samples or to calibrate a sensor in an (**OMOVE** start sequence (buffer solutions)).

Special beakers are moved in front of tower 1 with the following command.

```
MOVE_B      Special beaker  spec1  to tower  1
```

Reserved special beaker positions, which can be defined separately for each rack, are recognized as such in a method run and skipped when the individual sample beakers are being processed.

If a special beaker is required in a method run but no special beaker is present in the reserved position at the sample changer then an error message is always displayed.

The softkey [**Special beakers**] opens the dialog window in which the special beaker positions in the selected sample rack can be edited.

Rack 1		
#	Spec.beaker	Position
1	Rinse	12
2	Cond.	11
3	spec.3	0
4	spec.4	0
5	spec.5	0
6	spec.6	0
7	spec.7	0
8	spec.8	0

QUIT

**Spec.beaker** Freely selectable name of the special beaker.

**Position** Rack position of the special beaker (0=not defined)  
It is recommended that special beakers are not placed in the first rack positions but in higher rack positions.

### 3.2.3 Basic configuration of a 717 Sample changer

The softkeys [**Changer 1**] and [**Changer 2**] open the dialog window for the definition of the basic configuration of the sample changer.

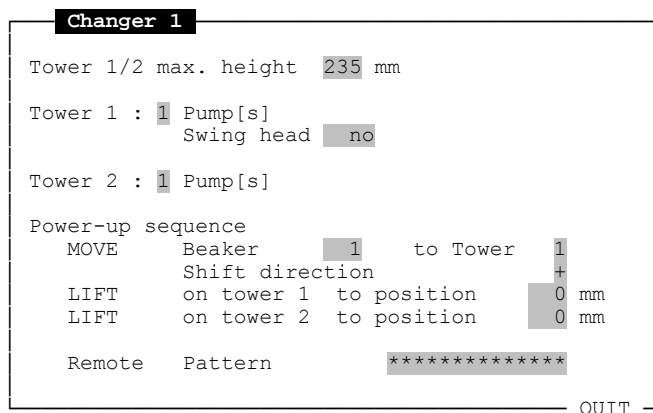

#### Lift stations

##### Tower 1/2

**max. height** The maximum height (in mm) of the tower determines the path which the lift of a tower can move. As the rest position (0 mm) of the lift is always at the upper stop of a tower the deepest lift position possible should be entered here; this ensures that sensors at the lift head are not damaged by careless lowering of the lift.

Depending on the model version of the sample changer the following information must be entered correctly:

##### Tower 1/2

**Pump[s]** Number of pumps at the corresponding tower.

**Swing head** Presence of a 759 Swing head if multi-row sample racks are used. A swing head should always be mounted on tower 1.

#### Power-up sequence

A sample changer is always initialized on switch-on i.e. the lift stations move to the rest position (0 mm), the sample turntable rotates to the initial position so that the rack code can be read.

Under some circumstances it may then be required that other positions are moved to or that peripheral devices which are connected must be activated.

For this purpose the 796 Titroprocessor offers the possibility of carrying out a switching-on sequence at the connected 717 Sample changers **after the sample changers have been initialized at power-up.**

**Power-up sequence**

```
MOVE Beaker 1 to tower 1
      Shift direction +
```

- The sample changer moves the beaker to the given rack position below the lift of tower 1 or 2, keeping to the defined direction of rotation (direction of rotation + = counterclockwise, ascending positions)

```
LIFT on tower 1 to position 0 mm
LIFT on tower 2 to position 0 mm
```

- The lifts of both towers can be set individually to any position required.

```
Remote Pattern *****
```

- The condition of the output lines at the remote socket of the sample changer can be deliberately set so that connected peripheral devices can be activated.

### 3.3 Interface configuration

The interface configuration can be accessed via the softkeys [Config.] and [Interfaces].

Configuration (Program version 5.796.0010)

Dialog in english LCD contrast 105 Screen save 30 min Error beep on Edit beep off Edit modus insert User level Standard Key card no Monitoring off	<p style="text-align: center; background-color: black; color: white; margin: 0;"><b>Configuration: Interfaces</b></p> <table style="width: 100%; border-collapse: collapse;"> <thead> <tr> <th style="text-align: left;">RS232</th> <th style="text-align: left;">Intface1</th> <th style="text-align: left;">Intface2</th> </tr> </thead> <tbody> <tr> <td>Baud rate</td> <td>9600</td> <td>9600</td> </tr> <tr> <td>Data bit</td> <td>8</td> <td>8</td> </tr> <tr> <td>Stop bit</td> <td>1</td> <td>1</td> </tr> <tr> <td>Parity</td> <td>none</td> <td>none</td> </tr> <tr> <td>Handshake</td> <td>HWshort</td> <td>HWshort</td> </tr> <tr> <td>Receive mode</td> <td>on</td> <td>on</td> </tr> <tr> <td>Balance</td> <td>----</td> <td>----</td> </tr> <tr> <td>Printer</td> <td>----</td> <td>----</td> </tr> <tr> <td colspan="3" style="text-align: center;">Communication Int. 1</td> </tr> <tr> <td colspan="3" style="text-align: center;">Commun. mode LIMS</td> </tr> <tr> <td colspan="3" style="text-align: center;">Internal printer on</td> </tr> <tr> <td colspan="3" style="text-align: center;">Enable auto FF on</td> </tr> </tbody> </table>	RS232	Intface1	Intface2	Baud rate	9600	9600	Data bit	8	8	Stop bit	1	1	Parity	none	none	Handshake	HWshort	HWshort	Receive mode	on	on	Balance	----	----	Printer	----	----	Communication Int. 1			Commun. mode LIMS			Internal printer on			Enable auto FF on			DATA ent1>.### +Meth+Remark f trohm (Bkup) f
RS232	Intface1	Intface2																																							
Baud rate	9600	9600																																							
Data bit	8	8																																							
Stop bit	1	1																																							
Parity	none	none																																							
Handshake	HWshort	HWshort																																							
Receive mode	on	on																																							
Balance	----	----																																							
Printer	----	----																																							
Communication Int. 1																																									
Commun. mode LIMS																																									
Internal printer on																																									
Enable auto FF on																																									

QUIT QUIT

	Reset RS232 1	Reset RS232 2	Cancel
--	---------------	---------------	--------

For the connection of external printers, balances or computers/LIMS (or other peripheral devices) two serial RS232 interfaces are available. For interface 1 (Intface1) and interface 2 (Intface2) the interface parameters are listed in two columns. Always make sure that the interface settings coincide with those on the connected instruments.

### 3.3.1 Setting the RS232 interfaces

<b>Baud rate</b>	Transmission speed
<b>Data bit</b>	Number of data bits
<b>Stop bit</b>	Number of stop bits
<b>Parity</b>	Type of parity check
<b>Handshake</b>	Type of protocol
<b>Receive mode</b>	Allows or blocks the reception of transmitted data

### 3.3.2 Balances and printers

Enter the type of balance or printer used in the column allocated to the RS232 interface to which the corresponding instrument is connected, see Titroprocessor rear panel.

<b>Balance</b>	Manufacturer or type of connected balance
<b>Printer</b>	Manufacturer or type of printer – Select ' <b>HP-Deskjet</b> ' for inkjet printers (with RS232 interface) from Hewlett-Packard or HP-compatible laser printers – Select ' <b>Epson 80*60</b> ' or ' <b>Epson 60*72</b> ' for Epson printers or matrix printers from other manufacturers. (80*60 means a graphics resolution 80 dpi by 60 dpi). – Select ' <b>IBM Proprinter</b> ' if your printer does not produce a satisfactory printout with the above settings.

If the Titroprocessor 796 does not have a built-in thermal printer then a connection socket 'Printer' will be found on the rear panel of the instrument. A normal commercial printer can be connected to this socket with a parallel Centronics interface. This printer should be defined under '**Printer port**'.

```

communication Int. 1
commun. mode      LIMS

Printer port
-----
Printer           ----
QUIT
  
```

### 3.3.3 Data communication settings

The Titroprocessor 796 can communicate with a PC or a LIMS system via the RS232 interfaces. This ensures that reports or determination files, etc. can be stored on a computer. It is also possible to operate the Titroprocessor in a key-simulation mode with the aid of a personal computer and suitable software.

The settings:

#### Communication

<b>Int.</b>	RS232 interface for the connection to a PC
<b>Commun. mode</b>	Data transmission mode:
<b>keyCTRL</b>	Remote control of Titroprocessor by key-code simulation, see page 278f.
<b>keySEND</b>	Transmit key-codes . The Titroprocessor sends the codes of the keys pressed via the RS232 interface.
<b>LIMS</b>	Data output to a PC or a LIMS system, e.g. for raw data reports to the database software Metrodata <b>VESUV 3</b> .
<b>off</b>	No data transmission

### 3.3.4 Internal thermal printer

These settings are only available on Titroprocessor models 2.796.0020 and 2.796.0120.

The built-in printer can be used as well as an external printer connected to an RS232 interface.

**Internal printer** Switches the internal printer on/off. A printout of the screen contents with the <PRINT SCREEN>key is still possible with the '**off**' setting.

#### Enable

**auto FF** '**off**' allows the use of the automatic page feed in report definitions. If Metrohm thermal paper (Order no. 6.2237.040) is used the perforation is automatically skipped during printout.

### 3.3.5 Initializing the RS232 interfaces

If problems occur during data transmission or data reception via the RS232 interfaces it may be necessary to initialize the affected interface again. This can be carried out by pressing the softkeys [**Reset RS232 1**] or [**Reset RS232 2**].

During initialization of an RS232 interface the reception buffer and the output buffer of the RS232 interface are cleared and the transmission parameters newly set.

The Titroprocessor 796 interfaces are set to a time out period (time out) of 30 seconds, i.e. if data are to be transmitted to an external instrument then a connection must be made to this instrument within 30 seconds, otherwise a connection problem is assumed and a corresponding error message displayed.

If this occurs with a printer then first check whether it has been correctly connected and is switched '*online*'.

### 3.4 Buret units

The definition of a buret unit is used to fix the parameters of different tubing of exchange units and dosing devices. The tubing dimensions (length and diameter) are used in order to calculate the optimal volumes for rinsing the tubings and the buret cylinder. These definitions of the buret units are made with the commands **Prepare (PREP)** and **Empty (EMPTY)** only with Dosinos), as well as the corresponding manual functions.

If the exchange and dosing units you use have different tubing dimensions from the tubing supplied as standard then you must define your own type of buret units.

Exchange units (for Dosimat 685) and dosing units (for Dosino 700) should always be prepared before a sample series is carried out, i.e. completely rinsed with reagent in order to ensure that all tubing is complete and homogeneously filled without any air bubbles. In this way the greatest possible accuracy which these extremely precise dosing systems allow is achieved for every determination.

- If in a method the **PREP** or the **EMPTY** command (only for Dosinos) is used then the name of the type of buret unit must be given.

```
PREP      Tubing      Default  Dos. drive  A1
```

- If the preparation of a buret unit (emptying only for Dosinos) is to be carried out manually, (dialog page '**Devices & Manual Control**', see below) then the type of buret unit must also be given:

```
Dos. drive  A1      700
Reagent     HCl
Concentr.   0.1 mol/L
Tubing      Default
Buret type  10.0mL
Piston position exchange
Dosing status ready
```

### 3.4.1 Tubing definitions

Configuration (Program version 5.796.0010)

Dial **Tubings**

LCD Dosino 700: Dosing units, tubing and preparation

Erro

Edit

Edit

#	Type	Dosier tube		Aspiration tube		Outlet
		Length	Diameter	Length	Diameter	
1	Default	40 cm	2 mm	25 cm	2 mm	Tip
2	Changer	100 cm	2 mm	25 cm	2 mm	Tip
3		cm	mm	cm	mm	
4		cm	mm	cm	mm	
5		cm	mm	cm	mm	
6		cm	mm	cm	mm	
7		cm	mm	cm	mm	
8		cm	mm	cm	mm	
9		cm	mm	cm	mm	
10		cm	mm	cm	mm	

QUIT

QUIT

		Rates			685 Dosimat	Delete line	Delete line	Check type
--	--	-------	--	--	----------------	----------------	----------------	---------------

700  
Dosino

#### Softkeys

- [Rates]** opens the dialog window for the definition of the dosing and filling speeds for the **PREP** and the **EMPTY** functions for dosing units.
- [685 Dosimat]** opens the dialog window for the definition of the buret unit type for the exchange units of 685 Dosimat.
- [700 Dosino]** opens the dialog window for the definition of the buret unit type for the dosing units of the 700 Dosino.
- [Delete line]** deletes the selected line.
- [Delete all]** deletes all buret unit definitions.
- [Check type]** carries out a short test to check whether a type name has been used several times.

### 3.4.2 700 Dosino, dosing units

The tubing dimensions for dosing units:

**Type** Name of the buret unit. Two types are already predefined. (**Default**=standard tubing parameters, see above, **Changer**=standard tubing parameters for sample changer applications, see above.)

**Dosing tube**

**Length** Length (in cm) of the dosing tubing connected to port 1 of the dosing unit.

**Diameter** Inner diameter (in mm) of the dosing tubing connected to port 1.

**Aspiration tube**

**Length** Length (in cm) of the aspiration tube connected to port 2 of the dosing unit (=thicker connection on the bottom of the dosing unit).

**Diameter** Inner diameter (in mm) of the aspiration tube connected to port 2.

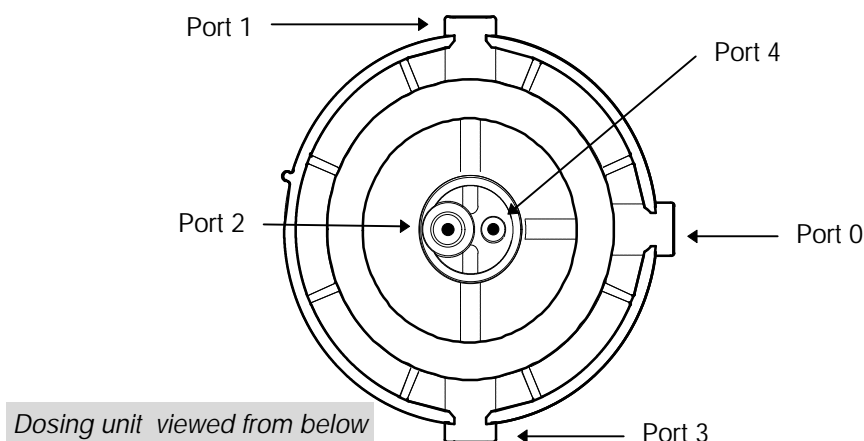

**Outlet** Where the reagent is disposed of after rinsing the buret unit (**PREP** and **EMPTY**) is defined here.

**'Tip'** = the total rinsing volume is ejected via the dosing tip .

**'Flask'** = the cylinder contents are returned to the reagent bottle via port 4, the contents of the dosing tubing is ejected via the dosing tip.

The definition of a buret unit is only complete when all information has been entered correctly.

### Dosing and filling speeds for PREP and EMPTY

Tubings					
Dosino 700: Dosing units, rates					
#	Type	Dosing rate		Filling rate	
1	Default	max	mL/min	max	mL/min
2	Changer	max	mL/min	max	mL/min
3			mL/min		mL/min
4			mL/min		mL/min
5			mL/min		mL/min
6			mL/min		mL/min
7			mL/min		mL/min
8			mL/min		mL/min
9			mL/min		mL/min
10			mL/min		mL/min

QUIT

The dosing and filling speeds for the **PREP** and **EMPTY** functions of the dosing units (**EMPTY** only for 700 Dosino) are defined here. They only apply to these functions.

**Type** Name of the buret unit, see above.

**Dosing rate** The maximum value for the dosing speed depends on the cylinder size of the buret used.

<i>Buret cylinder</i>	<i>Max. speed</i>
1 mL	3 mL/min
2 mL	6 mL/min
5 mL	15 mL/min
10 mL	30 mL/min
20 mL	60 mL/min
50 mL	150 mL/min

For smaller buret cylinders a value of up to 150 mL/min can also be entered, but when the function is carried out the dosing speed will automatically be reduced to the largest possible value. Whenever possible 'max' should be selected, except for viscous reagent solutions.

**Filling rate** The same applies for the filling speed. Please note that with viscous solutions too rapid filling can cause a partial vacuum in the cylinder (bubble formation!).

### 3.4.3 685 Dosimat, exchange units

For the 685 Dosimat exchange units the types of buret units are not defined as tubing dimensions. In this case the rinsing volume and the number of rinsing cycles are entered .

The same names can be used as for the dosing units of the 700 Dosino. The 796 Titroprocessor can determine the type of dosing unit itself.

Configuration (Program version 5.796.0012)

Dial **Tubings**

LCD Dosimat 685: Exchange units, preparation

LCD

#	Type	Volume	Cycles	Dosing rate	Filling rate
1	Default	3.5 mL	2	max mL/min	max mL/min
2	Changer	10.0 mL	2	max mL/min	max mL/min
3		mL		mL/min	mL/min
4		mL		mL/min	mL/min
5		mL		mL/min	mL/min
6		mL		mL/min	mL/min
7		mL		mL/min	mL/min
8		mL		mL/min	mL/min
9		mL		mL/min	mL/min
10		mL		mL/min	mL/min

QUIT

QUIT

			700 Dosino	Delete line	Delete all	Check type
--	--	--	---------------	----------------	---------------	---------------

**Type** Name of the buret unit. Two types are already predefined. (**Default**=standard settings, see above, **Changer**=standard setting for sample changer applications, see above.)

**Volume** Reagent volume for one rinsing cycle.

**Cycles** Number of rinsing cycles to be carried out.

**Dosing rate** The maximum value for the dosing speed depends on the cylinder size of the buret used.

Buret cylinder	Max. speed
1 mL	3 mL/min
2 mL	6 mL/min
5 mL	15 mL/min
10 mL	30 mL/min
20 mL	60 mL/min
50 mL	150 mL/min

For smaller buret cylinders a value of up to 150 mL/min can also be entered, but when the function is carried out the dosing speed will automatically be reduced to the

largest possible value. Whenever possible 'max' should be selected, except for viscous reagent solutions.

**Filling rate** The same applies for the filling speed. Please note that with viscous solutions too rapid filling can cause a partial vacuum in the cylinder (bubble formation!).

# 4 Manual operation

For manual operation or for monitoring peripheral devices (dosing devices, sensors, sample changers, remote lines) the page 'Devices & Manual control' should be called up. Press the softkey [Devices ManCtrl] on the main page or the <MAN CONTROL> key on the keyboard.

## 4.1 Overview

```

Devices & Manual Control
-----
Dosing devices at interface A                                press <TAB> for more
Dos. drive          A1          700          A2          685          A3          ---          A4          ---
Reagent            AgNO3          HCl
Concentr.          0.01 mol/L      0.1 mol/L
Tubing             Default        Default        Default        Default
Buret type         10.0mL          20.0mL
Piston position    exchange        exchange
Dosing status      ready          ready

-----
Sensors at interface A                                    press <TAB> for more
Meas. input        A1          A2          Adiff          AT
Sensor            6.0430.100  6.0232.100
Cal. sensor
Cal.method
Cal.date
Next Calibr.      99-12-10 14:37  99-12-14 08:00
pH(as)            7.000          6.987          7.000
Slope             1.000          0.996          1.000
Stirrer           on
-----
QUIT
-----
Sample changer | Calibr. | Meas | Stirrer on/off | Remote lines
    
```

The upper part of the screen shows the status of the dosing devices which are connected to the Titroprocessor. The lower part of the screen shows the status of the sensors.

Each dosing device and sensor is identified by an address (A1, A2, ...). This stands for the corresponding connection. The type of dosing device (685 Dosimat or 700 Dosino) is automatically recognized when the Titroprocessor is switched on.

### Address allocation scheme:

- |                |                  |   |
|----------------|------------------|---|
| Dosing devices | <b>A1 ... A4</b> | Dosing devices at 796 Titroprocessor                                  |
|                | <b>B1 ... B4</b> | Dosing devices at 729 Dosimat interface /EBus                         |
|                | <b>C1 ... C4</b> | Dosing devices at 729 Dosimat interface /EBus                         |
| Sensors        | <b>A1, A2</b>    | Measuring electrodes at measuring group 'Sensors A'                   |
|                | <b>Adiff</b>     | Differential amplification arrangement at measuring group 'Sensors A' |
|                | <b>AT</b>        | Temperature sensor Pt100/1000 of measuring group 'Sensors A'          |
|                | <b>Apol</b>      | Polarized electrode of measuring group 'Sensors A'                    |

<b>B1, B2</b>	Measuring electrode of measuring group 'Sensors B'
<b>Bdiff</b>	Differential amplification arrangement at measuring group 'Sensors B'
<b>BT</b>	Temperature sensor Pt100/1000 of measuring group 'Sensors B'
<b>Bpol</b>	Polarized electrode of measuring group 'Sensors B'

In order to operate an instrument or a sensor move the field cursor to the corresponding editing block and press the corresponding softkey. Press the <PG DN> or <PG UP>key to change between dosing devices and sensors. In order to address additional instruments, e.g. dosing devices **B1 ... C4** or a sensor in measuring group **B**, press the <TAB>key. <↑><TAB> or <TAB> can be used to switch between the screens of the various interfaces or measuring groups.

## 4.2 Dosing devices

Twelve dosing devices can be connected simultaneously to the 796 Titroprocessor and comfortably operated by 'Manual control'. It is possible to operate dosing devices manually while determinations are being carried out. The dosing devices in use are blocked for manual operation by the Titroprocessor; they are marked as '**locked**'.

The name and concentration of a reagent can be entered for each dosing device. The operator can use this to force the Titroprocessor to check the reagent required for a method before it is used.

### 4.2.1 Automatic reagent check

In order to ensure that the dosing device settings in a method coincide with the current settings of the manual control page (in which the actual occupancy of the dosing devices should be entered) it is possible to force a comparative check to be carried out.

If a reagent name and/or a concentration for a dosing device have been entered in the method and in the 'Manual control page' then an automatic reagent check is carried out. The two entries are compared with each other. Variations in a reagent entry or its concentration produce an error message at the start of the particular command or mode.

The automatic reagent check is suppressed if no entries have been made for reagent and concentration in the method or if the corresponding entries have been completely deleted in 'Manual control page'.

Dos. drive	A1	700	← Manual control page
Reagent	AgNO3		
Concentr.	0.01 mol/L		

↓ Method

DET_PH*	Determination of chloride		
Reagent	AgNO3	Sensor	
Concentr.	0.01 mol/L	Meas. input	A1
Dos. drive			A1

In titration modes the '**Reagent**' field is a selection list in which the reagent names and concentrations available on the manual control page are present.

### Buret units

In order that the **Prepare (PREP)** and **Empty (EMPTY)** only for 700 Dosino) functions can be optimally used the correct type of buret unit should be selected for each dosing device.

Concentr.	0.01 mol/L	
Tubing	Default	← Buret unit type
Buret type	10.0mL	(with selection list)

The definition of buret units with their corresponding tubing parameters can be carried out during configuration, see page 47ff.

### 4.2.2 Dosing device functions

In order to operate a Dosimat or Dosino manually place the field cursor in the column of the required dosing device and press the corresponding softkey.

#### Softkeys

<b>[Fill all]</b>	causes all connected dosing devices to fill their burets.
<b>[Fill]</b>	triggers buret filling for the selected dosing device.
<b>[Prepare buret]</b>	triggers a preparation cycle ( <b>PREP</b> ) for the selected dosing device. The tubing and cylinder of the buret unit are rinsed in accordance with the tubing parameters of the type of buret unit (see page 47ff).
<b>[Dosing drive]</b>	opens the dialog window for manual dosing with the selected dosing device, see below.
<b>[Empty]</b>	triggers emptying ( <b>EMPTY</b> ) the buret of the selected dosing device. The tubing and cylinder of the buret unit are emptied in accordance with the tubing parameters of the type of buret unit (see page 47ff). This is only possible with 700 Dosinos.
<b>[STOP]</b>	stops the current process for the selected dosing device.
<b>[STOP all]</b>	stops all connected dosing devices.

In order to achieve the highest possible accuracy and to ensure that there are no air bubbles in the tubing the **'Prepare'** function should be carried out before the start of a series of determinations. This function should be used as often as is necessary, but at least once per day.

The **'Empty'** function is useful if the reagent in a buret unit is to be exchanged. The tubing and the buret cylinder are emptied so that the reagent can be exchanged without great loss of reagent.

The **'Prepare'** and **'Empty'** functions are automated filling and dosing processes which take the volumes of the buret unit cylinder tubing into account. This is why it is necessary to enter the dimensions of the tubing as

well as the outlet port (for Dosinos) through which the reagent will be expelled in this process, see page 47ff.

### 4.2.3 Manual dosing

In order to operate a Dosimat or a Dosino manually place the field cursor in the column of the required dosing device and press the [**Dosing drive**] softkey.

```

Dosing
Dos. drive  : A1
Volume      50.00 mL
Dos. rate   max mL/min
Fill. rate  max mL/min
Pist. pos.  0.000 mL
* 0.000 mL *
QUIT
  
```

Fill	HOLD CONT	Start dosing	STOP
------	--------------	-----------------	------

Enter the reagent volume to be dosed in. Alter the dosing and filling speeds if necessary.

#### Softkeys

[ <b>Fill</b> ]	fills the buret.
[ <b>HOLD CONT</b> ]	interrupts or restarts the dosing process.
[ <b>Start dosing</b> ]	doses in the preselected volume.
[ <b>STOP</b> ]	breaks off the dosing process.

### 4.3 Sensors

Depending on the Titroprocessor model, two measuring groups could be built in. The connected sensors can be operated from the 'Manual control page'. A manual measurement is also possible while a determination is being carried out. The sensors in use are blocked for manual operation by the Titroprocessor. Manual measurements can only be carried out with one sensor at a time.

A name can be entered for each sensor or measuring input.

#### Softkeys

**[Calibr.]** opens the dialog window for the calibration of pH electrodes.

**[Meas]** opens the dialog window for manual measurements.

The required sensor (**A1**, **A2**, **Adiff**, **AT** or **Apol**) is first selected with the cursor keys before a softkey is pressed. The tab key is used to access the sensors of measuring group **B**.

#### 4.3.1 Automatic sensor check

In order to ensure that sensor name in a method coincides with the current settings of the manual control page (in which the actual occupancy of the measuring inputs should be entered) it is possible to force a comparative check to be carried out.

If a sensor name has been entered in the method and in the 'Manual control page' then an automatic sensor check is carried out. The two entries are compared with each other. If they do not agree an error message is produced at the start of the particular mode.

The automatic sensor check is suppressed if no entries have been made in the method or if the corresponding entries have been completely deleted in the 'Manual control page'.

Meas. input	A1	
Sensor	6.0232.100	← Manual control page
		↓ Method
DET_PH*	Determination of chloride	
	Reagent AgNO3	Sensor 6.0232.100
	Concentr. 0.01 mol/L	Meas. input A1
	Dos. drive	A1

#### 4.3.2 Manual measurement

Measurements can be carried out by selecting the measuring input to which the corresponding sensor is connected. The **[Meas]** softkey opens a dialog window in which the measurement parameters, e.g. measuring mode or measuring temperature can be modified according to the type of sensor.

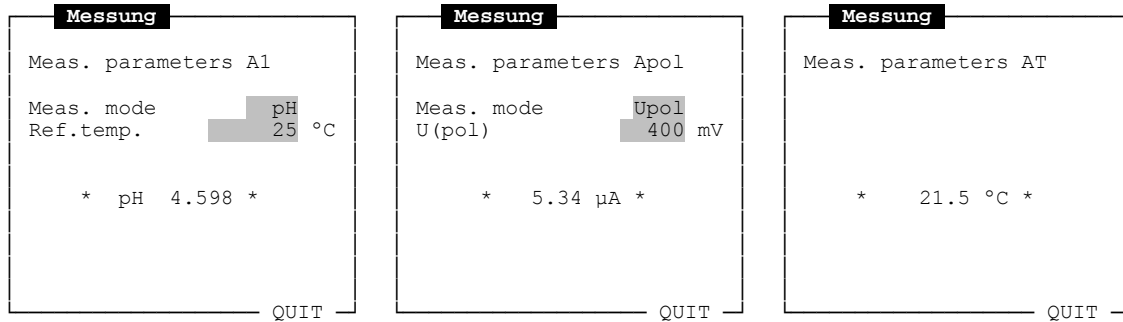

Depending on the selected measuring input the following measuring modes can be used:

- pH** pH measurement, with temperature correction
- U** potential measurement in mV
- Upol** measurement of polarization current with preselected polarization voltage
- Ipol** measurement of polarization voltage with preselected polarization current
- T** temperature measurement with Pt100/1000

The **[start stop]** softkey starts the measurement or breaks it off again.

### 4.3.3 Calibration

pH sensors at measuring inputs **A1**, **A2**, **Adiff**, **B1**, **B2** and **Bdiff** can be calibrated. The calibration data of the particular measuring input remain unchanged until they are altered, even if the Titroprocessor is switched off. The **[Calibr.]** softkey opens the calibration window.

Devices & Manual Control

---

Dosing devices at interface A press <TAB> for more

Dos. drive	A1	700	A2	685	A3	---	A4	---
Reagent	AgNO3		HCl					
Concentr.	0.01 mol/L		0.1 mol/L					
Tubing	Default		Default		Default		Default	

**Calibration**

Meas. parameters A1:	#	Buffer	pH val.	T[°C]	pH cor.	Val.[mV]
Signal drift	2	Metrohm	4.000	23.0	3.996	175.6
Equilibr.time	110	2 Metrohm	7.000	23.0	7.008	0.9
Temperature	23.0					
Buffer type Metrohm	4.00	..9.00				

Buffer **3** pH XXXXXXXXXX

QUIT

Preset series	Add series	
---------------	------------	--

Start Stop		
------------	--	--

Clear calibr.	Cancel calibr.	Show curve
---------------	----------------	------------

The buffers required for the calibration of a pH sensor can be defined individually or a predefined buffer series can be used. Many buffer solution manufacturers offer complete buffer series. Calibration with two buffer solutions (two-point calibration) is normally adequate.

**Softkeys**

- [Preset series] lists all the buffer solutions of the selected manufacturer or type in the buffer table.
- [Add series] adds the whole list of buffer solutions of the selected manufacturer or type to the existing buffer table.
- [Start Stop] starts or stops a measurement.
- [Clear calibr.] deletes the existing calibration or the calibration data. The buffer table used for this can remain if the query shown on deletion is answered with 'n'.
- [Cancel calibr.] breaks the started calibration off. The previous calibration data are restored and the calibration window closed.
- [Show curve] shows the currently valid calibration curve, see example below.

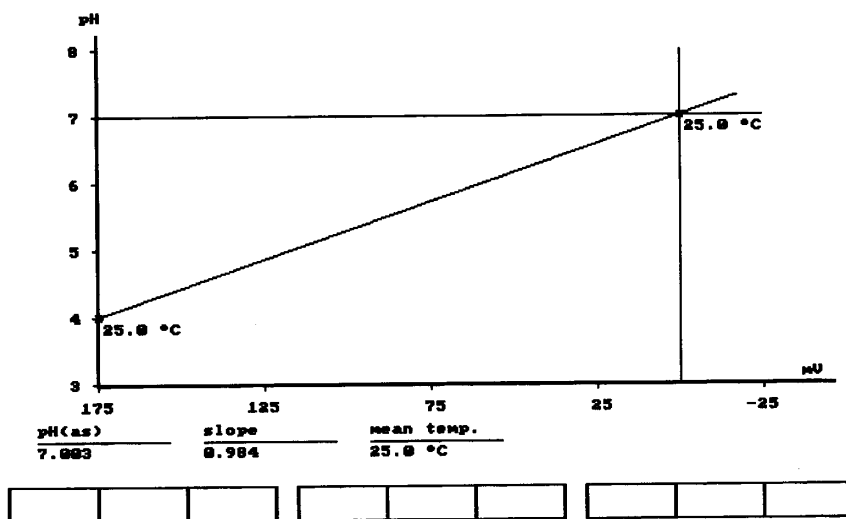

As in titrations and measurements, the measuring parameters can be individually selected for the sensor calibration.

## Measuring parameters

---

**signal drift**    **Limits for signal drift** 0.5...2...999 mV/min | off

The measurement is only accepted if the measurement change of the sensor falls below the preset value for the signal drift. If this is delayed, the measurement will nevertheless be accepted when the preset equilibration time (see below) has elapsed. This signal drift control can be switched off ('**off**'). However, this cannot be recommended for correct calibration.

---

**Equilibr.time**    **Max. equilibration time before measurement acceptance** 0.1...9999 s | **auto** | off

The whole equilibration time for measurement acceptance is only effective when, with drift control switched on (see signal drift above), the preset value for signal drift is not undercut. Otherwise the measurement is accepted as soon as the preset signal drift is achieved.

The whole equilibration time will also be allowed to elapse if the drift control is switched off.

The equilibration time can be switched off. This means that only the signal drift is decisive for measurement acceptance.

In the setting '**Equilibr.time auto**' the Titroprocessor will calculate an equilibration time suited to the preset value for the signal drift according to the following equation:

$$\text{Equilibr. time (in s)} = \frac{150}{\sqrt{\text{drift} / (\text{mV} / \text{min}) + 0,01}} + 5$$

For the standard setting 2 mV this results in an equilibration time of 110 s.

---

**Temperature**    **Temperature setting or measuring mode** -170...**25.0**...500°C | **auto** | off

The temperature can be determined during a measurement with the help of a Pt100/Pt1000 sensor or a combined electrode with built-in temperature sensor. It is required for automatic pH correction.

<i>numeric</i>	manual input
<i>auto</i>	automatic measurement during the calibration
<i>off</i>	no temperature correction

### Buffer solutions

As buffer solutions can have very different compositions it is necessary to give the correct buffer type so that the temperature correction is correctly used for the calibration.

Select a buffer type or manufacturer. Insert a buffer series into the buffer table by pressing the [**Preset series**] softkey or [**Add series**].

Calibration is also possible without a predefined buffer list. The buffer (type and value) can be entered individually. Different types of buffer can also be used. If your type of buffer is not contained in the selection list then select '**none**'.

Enter the nominal value of your buffer solution in the line

Buffer 1 pH

and start a measurement with the [**Start Stop**] softkey.

During the calibration the values found are compared with the predefined values of the buffer solutions (theoretical value, temperature with automatic temperature measurement) and subjected to a plausibility test, see page 118. If this should cause annoying error messages with '*exotic*' buffers or '*unusual*' sensors then select buffer type '**custom**' for user-defined buffer types. No plausibility tests are carried out in this setting.

After each buffer solution measurement the calibration values are entered in the buffer table.

#	Buffer	pH val.	T[°C]	pH cor.	Val.[mV]
1	Metrohm	4.000	23.0	3.996	175.6
2	Metrohm	7.000	23.0	7.008	0.9

The buffer table includes the following data:

- buffer type or manufacturer
- nominal pH
- buffer temperature
- (temperature)-corrected effective pH
- measured potential in mV

When a measurement has been completed the next buffer solution can be entered and measured.

After at least two measurements have been made the calibration curve can be displayed by pressing the [**Show curve**] softkey. The corresponding values for the slope and the asymmetry pH ( $\text{pH}_{\text{as}}$ ) are shown together with the calibration curve.

Calibration data are allocated to a measuring input (e.g. **A1**) and stored in the Titroprocessor. The calibration data can be checked at any time. Before a sensor is recalibrated the previous calibration must be deleted with the **[Clear calibr.]** softkey.

### Calibration data and calibration interval

Sensors at interface		A	
Meas. input	A1	A2	
Sensor	6.0203.100	6.0232.100	
Cal. sensor	comb. glass	6.0232.100	
Cal. method	* by edit *	manual	
Cal. date	97-12-15 15:46	97-12-10 14:37	
Next Calibr.		97-12-14 08:00	
pH(as)	7.000	6.987	
Slope	1.000	0.996	

The 'Manual control page' always shows the calibration data for each measuring input with the name of the calibrated sensor, the calibration method (calibrations can be carried out automatically by a determination or as part of a series of samples) as well as the date and time of the calibration. The time for the next calibration can be set additionally. An appropriate warning is displayed when this time has been reached. The calibration interval defined in this way is reset at each subsequent calibration, i.e. the time for the next calibration is automatically calculated.

The calibration data pH<sub>as</sub> and slope can – if necessary – be manually altered. Previous calibrations will be overwritten.

Further information about calibration can be found on page 116f.

### 4.4 Sample changer

One or two sample changers (if connected) can be operated from the sample changer window which is accessed with the [Sample changer] softkey on the 'Manual control page'.

Devices & Manual Control

**Sample changer**

Do Changer 1: ready [000001] 2: not available

Do Rack type/name M12-0 - 12\*250mL

Ko Max. beakers 12

B<sup>n</sup> Tower 1 2

Ko Lift pos. [mm] 0 0

Do Beaker pos. 1 12

Beaker found yes no

Se Pumps

rinse	aspir	rinse	aspir
off	off	off	off

Me

Se

Ka Stirrer 1 2 3 4

Ka off off off off

Ka Stirring rate 3 3 3 3

NΣ

pH <PG UP> lift to shift position

St <PG DN> lift to work position; <HOME> lift to rest position

QUIT

QUIT

Reset changer	Remote lines	Stirrer on/off	Pump on/off	Lift up	Lift down	Shift left	Shift right	Shift to pos.
---------------	--------------	----------------	-------------	---------	-----------	------------	-------------	---------------

The sample changer window shows the status of the connected sample changers. The softkey bar allows the components of each sample changer to be operated.

For each connected sample changer the data of the sample rack placed on it are shown, i.e. sample rack type, rack code and number of beaker positions.

The following status information is provided for each tower: lift position, current beaker position and the result of the automatic beaker test (whether a beaker is present or not).

The current status of each pump (rinsing or aspiration pump) and each stirrer is shown together with the stirrer speed which can be set in 15 steps. The stirrer speed can be entered directly in the particular entry field selected.

The cursor keys <←> and <→> (or <TAB>) can be used to select a tower, pump or stirrer. A frame shows the selected changer and tower for which a function can be triggered with a softkey. The field cursor (black background) shows the particular stirrer selected or pump selected.

## Softkeys

**[Reset changer]** initializes the sample changer. When a sample rack has been exchanged it is necessary to initialize the sample changer. In this process all lifts are moved to the rest position, the sample turntable is rotated to the initial position and the magnet code is read to identify the new rack.

**[Remote lines]** opens the dialog window of the remote-lines of the selected sample changer. The conditions of the logical input lines can be seen and the conditions of the output lines can be set.

```

Remote lines: 1
-----
I/O lines 32109876543210
-----
Input      00000001
Output    *****0001
-----
QUIT

```

The output lines can be set individually (1) or reset (0). Lines which are not to be altered can be given an '\*'. Further details can be found on pages 200f and 29f.

**[Stirrer on/off]** switches the selected stirrer on or off.

**[Pump on/off]** switches the selected pump on or off.

**[Lift up]** moves the lift of the selected tower upwards. This is only possible if the sample rack is aligned to the tower. With sample racks which are not expressly designed for two-tower operation e.g. 14-place or 16-place racks, the rack should first be rotated to the left or right by one position, see softkeys below.

**[Lift down]** moves the lift of the selected tower downwards. Please note the remarks about the previous softkey.

**[Shift left]** rotates the sample rack of the selected changer counterclockwise by one position. The lifts of the changer must be in the shift position or a higher position.

**[Shift right]** rotates the sample rack of the selected changer clockwise by one position. The lifts of the changer must be in the shift position or a higher position.

**[Shift to pos.]** opens the dialog window for targeted positioning of sample racks, see below.

### 4.4.1 Sample rack and lift functions

For safety reasons it is not possible to rotate a sample rack if a lift is in a lower position than the specified shift position. This is why it is important to determine the correct sample rack definitions with great care (see page 38). Press the **<PG UP>** key or **<HOME>** before the sample rack is to be rotated.

If a sample rack is used which has not been designed for parallel processing with a two-tower changer model (M14-0, M16-0, M19-0 ...) then a rack position must be correctly aligned in front of the particular tower so that the lift can be operated. This is done by marking the target tower and then rotating the sample rack to the left or right with the corresponding softkeys.

#### Move lift

The **<PG UP>** and **<PG DN>** keys bring the selected lift to the shift or working positions which are defined in the rack definitions of the mounted sample rack. The **<HOME>** key brings the lift to the rest position (0 mm position) at the topmost position of the selected tower. In order to move a lift millimeter by millimeter the **[Lift up]** and **[Lift down]** softkeys should be used.

#### Move beaker to absolute position

As well as the possibility of rotating the rack by one position (softkeys **[Shift left]** and **[Shift right]**) a particular beaker position which is to be placed in front of a tower by a rack rotation can be entered. Press the **[Shift to pos.]** softkey to carry this out

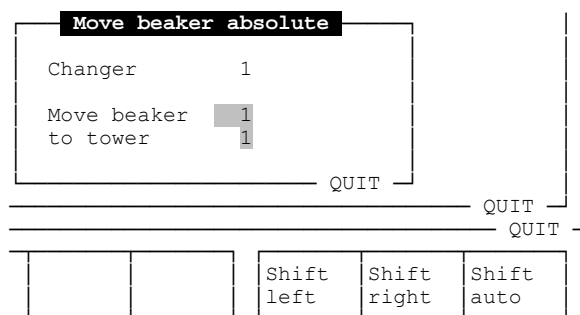

Which beaker is to be positioned in front of which tower can be entered here. Press a softkey to rotate the rack in the corresponding direction.

- [Shift left]** rotates the rack counterclockwise.
- [Shift right]** rotates the rack clockwise.

**[Shift auto]** rotates the rack automatically. The shortest rotary path is selected.

### 4.5 Stirrer at measuring interface

Each measuring group of the Titroprocessor 796 is equipped with a stirrer connection (12 V) to which various stirrers can be connected. These include:

- 728 Magnetic stirrer 2.728.0040
- 722 Rod stirrer 2.722.0010
- 727 Ti-Stand with rod stirrer 2.727.0010
- 727 Ti-Stand with magnetic stirrer 2.727.0100
- 703 Ti-Stand 2.703.0010

The stirrer connection of a measuring group (see rear view of instrument, page 4) is switched on as standard. It can be switched on the 'Manual control page' (<MAN CONTROL> key) with the **[Stirrer on/off]** softkey. If necessary select the first measuring group ('Sensors at interface A/B') with the <PG DN> and <TAB> keys.

The status of the stirrer connection is always shown at the bottom right-hand side.

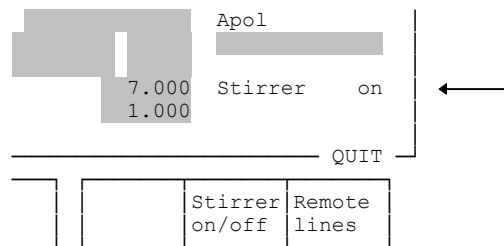

### 4.6 Remote lines (Input / Output)

The **[Remote lines]** softkey on the 'Manual control page' (<MAN CONTROL> key) opens the dialog window of the remote connection of the Titroprocessor 796.

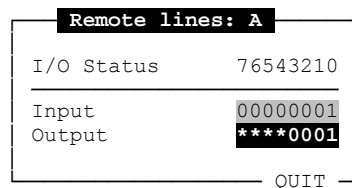

Here the conditions of the logical input lines can be seen and the conditions of the output lines can be set. The output lines can be set individually (1) or reset (0). Lines which are not to be altered can be given an '\*'. Further details can be found on pages 200f and 29f.

## 4.7 Print

The built-in A4 thermal printer or any other printer which has been connected and configured can be operated with the yellow printing keys.

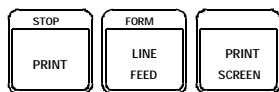

The <PRINT> key opens the printer menu from which any type of report can be selected. Global reports and determination reports (if a determination is present in the working memory) can be selected.

<↑><PRINT> (= **STOP PRINT**) interrupts a printout immediately.

<LINE FEED> causes a line feed if a printer is connected.

<↑><LINE FEED> (= **FORM FEED**) causes a page feed if a printer is connected. With page-oriented printers like laser printers and inkjet printers this key is used to eject the page .

<PRINT SCREEN> prints the current screen contents. This is always printed out on the built-in thermal printer or another printer connected to the parallel 'Printer' port.

### 4.7.1 The printer menu

The <PRINT>key calls up the printer menu.

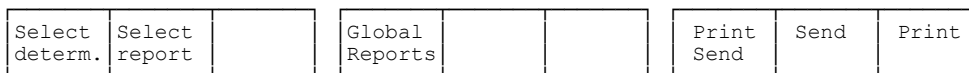
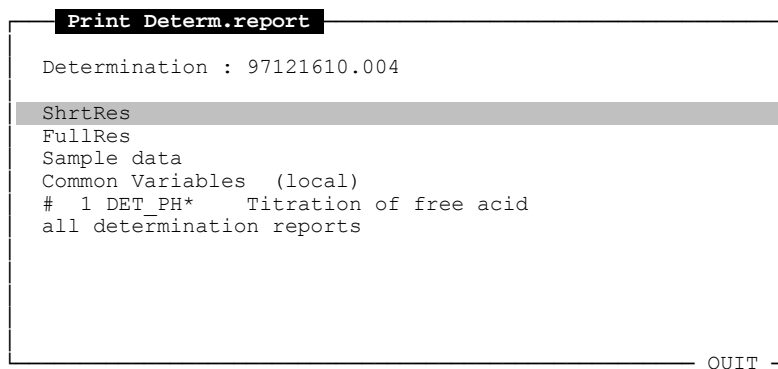

The printer menu shows the possible reports for the current determination. A report can be selected with the cursor keys <↓> and <↑> and the corresponding softkey can be used to print it out.

## Softkeys

- [Select  
determ.]** opens a selection list of the determinations in the working memory. A different determination for printing out reports can be selected.
- [Select  
report]** if a titration or measurement within a determination has been selected then this softkey opens the selection list containing possible report modes, see below.
- [Global  
Reports]** opens the dialog window for selection of the global reports, see below.

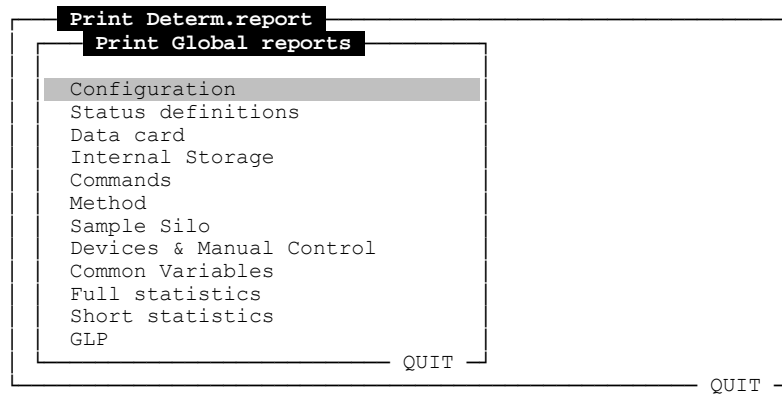

- [Send]** starts the output of the selected report to the communication interface. The report is transferred to the instrument (e.g. a personal computer) which is connected to the defined RS232 interface.
- [Print]** starts the output of the selected report at the configured printer.

### 4.7.2 General reports

General reports are not dependent on a determination. They present the momentary settings effective on the instrument.

- Configuration** Report of the settings in the configuration window and its sub-windows
- Status definitions** Report of the predefined status settings in standard user level.
- Data card** List of stored files on the data card
- Internal storage** List of stored files in the internal memory
- Commands** List of command sequences of the current method, without parameters
- Method** Comprehensive listing of the current method, including application remarks, command sequences and all their parameters.

<b>Sample Silo</b>	List of all sample data in the sample silo
<b>Devices &amp; Manual Control</b>	Report of the current settings on the 'Manual control page'
<b>Common Variables</b>	List of the global common variables
<b>Full statistics</b>	Comprehensive statistical report
<b>Short statistics</b>	Report of the statistical results
<b>GLP</b>	Report of the GLP results

### 4.7.3 Determination reports

---

Use the [**select determ.**] softkey to select a determination from the selection list in the working memory. Any alterations which may have been carried out to the settings or re-evaluations of the determination data are taken into account in reports printed out manually.

<b>ShrtRes</b>	Short result report of all results of the determination
<b>FullRes</b>	Comprehensive result report of the results of the determination
<b>Sample data</b>	Report of the sample data used in the determination
<b>Common Variables (local)</b>	List of the common variables stored with the determination

#### **all determination reports**

All the reports defined in the determination are printed out

All titrations and measurements in a determination are also listed in the printer menu, e.g.

```
# 1 MEAS_PH*  pH measurement
# 2 DET_pH*  Titration of free acid
```

If one of these lines is selected then after the [**select report**] softkey is pressed then a report can be printed out of one of the mode reports of this titration or measurement. All reports of the corresponding mode are possible.

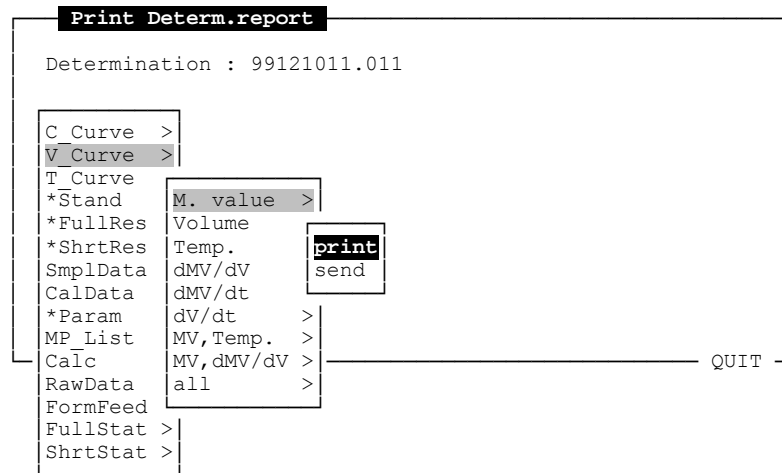

Details of the individual reports can be found on page 123ff.

# 5 Methods and determinations

## 5.1 General

A method must be loaded in the working memory in order to carry out a determination on a sample. The creation of a method for each application is recommended; this should be stored in the internal memory or on a data card so that it can be loaded and used whenever required.

A method consists of a sequence of different commands which are carried out when a sample is processed. The commands may be titration mode commands, measuring mode commands, sample changer commands or other commands. Up to five titration or measuring modes can be contained in one method. A total of 99 commands can be carried out in sequence. The easiest way of loading methods is with the <METHOD> key. This is also possible in the method editor via the [File] softkey or in the file manager with the key sequence [Copy to] 'Working memory'. If the **Auto start** function is used methods can also be loaded automatically from the sample silo.

If a sample changer is used (**Auto start 'on'**) then a start sequence and/or a closing sequence can be defined. A start sequence(**OMOVE ...**) **OMOVE** is carried out with the first sample of a series. A closing sequence(**CMOVE ...**) **CMOVE** is carried out with the last sample of a series.

Conditional command sequences (**CASE** structures) can be defined; these are only carried out when a particular condition has been fulfilled.

## 5.2 Method editor

The method editor is called up from the main page by pressing the [Edit method] softkey.

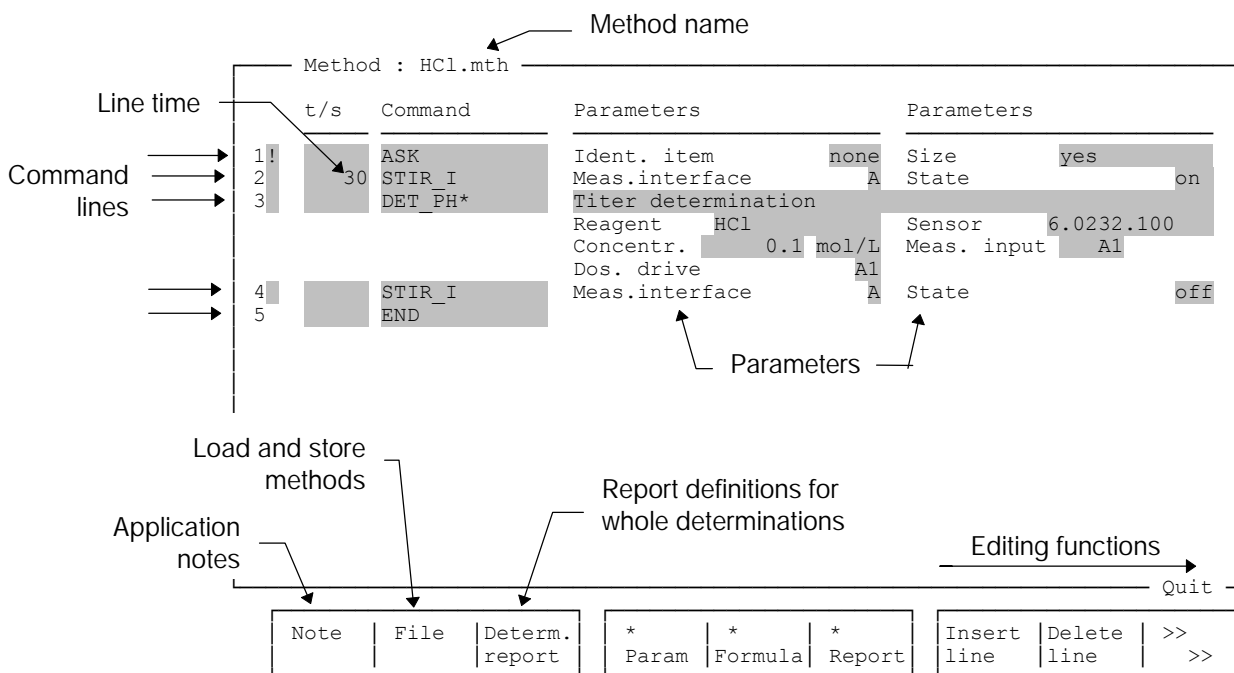

### 5.2.1 Load method

The **[File]** softkey is pressed in order to load an existing method; this opens the file dialog window.

#### File dialog window

Check whether the memory area from which the method is to be loaded has been correctly set. If this is the case then press the space bar to display the list of existing methods. The field cursor must be in the **'Name'** field. Use the cursor to select a method and confirm with **<ENTER>**.

	NaOH	:Titer of NaOH
	HCl	:Titer of HCl
	GLP	:Titer of HCl (validation method)
	CaMgTap	:Calcium / Magnesium in Tap Water
	Chloride	:Chloride in Tap Water
	Metals	:Complexometric Titration of Metals with Cu++ ISE
	Fe3_back	:Complexom. back titration of Fe(III) with Cu++ ISE
	Anionic	:Anionic Surfactants in Shampoo
	Cationic	:Cationic Surfactants in Fabric Softener
	Formol	:Formaldehyde Number in Fruit Juices
	Peroxide	:Peroxide Number
	TAN	:Total Acid Number (TAN)
	TBN	:Total Base Number (TBN)
	Diazo	:Diazotisation titration of 2-Aminophenol

<b>Files</b>	
Name	HCl .mth
Comment	Titer of HCl
Storage	Data card

QUIT

A selection of the methods which can be found on the application card supplied with the Titroprocessor 796 is shown above.

If the required method is to be found in a different memory area from that set then select this memory area in the way described above, but this time in the **'Storage'** field. The internal memory, a data card or the two RS232 interfaces can be selected. The way in which methods can be read in directly from a PC via the RS232 interfaces is described in section 11 File manager (page 225ff).

### 5.2.2 Create new method

In the method editor a new method is created by pressing the **[File]** key in order to open the file dialog window. Now press the **[New]** softkey.

An 'empty' method appears with an empty line and a line with the **'END'** command. A method must always be concluded with the **'END'** command, so do not delete this line.

In order to define the command sequence enter the required command in the command column manually (the first letters are sufficient) or select a command from the nested selection list.

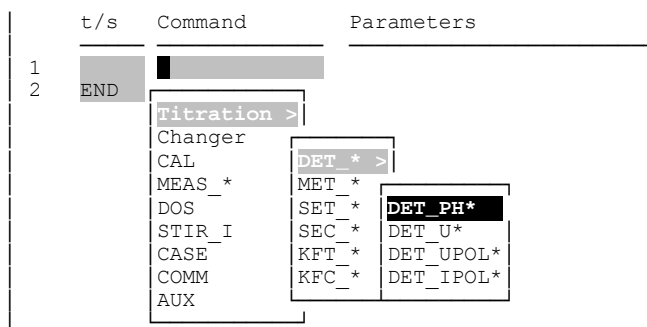

When the command has been accepted with <ENTER> the parameters of the selected command are shown and can now be edited. The titration and measuring modes (all \*commands) have extended sets of parameters. These can be accessed via the [\* ...] softkeys. If a command marked with an asterisk is marked with the cursor in the command column then the [\* Param] [\*Formula] [\*Report] softkeys are activated. In this way the further settings which only apply to this particular command or mode can be edited.

Method : HCl.mth

t/s	Command	Parameters	Parameters
1!	MEAS_PH*	pH measurement	
		Sensor 6.0232.100	Signal drift 50 mV/min
		Meas. input A1	Equilibr.time auto s
		Temperature 25.0 °C	
180	DET_PH*	Dynamic equivalence point titration	
		Reagent HCl	Sensor 6.0232.100
		Concentr. 0.1 mol/L	Meas. input A1
		Dos. drive A1	
	END		

Measuring mode

Titration mode

Allocation parameters

Mode-specific settings

Quit

Note	File	Determ. report	* Param	* Formula	* Report	Insert line	Delete line	>>	>>
------	------	----------------	---------	-----------	----------	-------------	-------------	----	----

A command line consists of a line number with the line attribute, the line time, a command name and the parameters.  
 With a '!' sign as line attribute the execution of a line can be suppressed (if required); see line 1 above. A block of lines to be suppressed can be marked with an '@' sign in the first and last lines. This possibility can be very useful when a newly created method is being tested.  
 A line time (see line 2 above) can be entered as an option; this sets a minimum time in which a command must be carried out. The next

command will not be carried out until this time has elapsed and the command involved has been carried out completely.

The functions and parameters of the individual commands are described in detail in section **8. Command references** (page 127ff).

A method is stored in the file dialog window (see page 72) with the **[Save]** softkey. The method name, storage area and an optional method commentary can be freely selected.

### 5.2.3 Softkeys and their functions

---

- [Note]** edits the application note which appears on the main page. A short description of the current method or of the sample preparation method can be entered. In the application note edit window. The **[Delete line]**, **[Blank line]** **[Copy line]** **[Paste line]** softkeys are available for comfortable text editing.
- [File]** The basic file operations are available in the file dialog window (see page 72).  
The name of a file can be freely selected or chosen from the selection list of the selected storage area by pressing the space bar. If files are to be saved on a computer system then file names should be selected which the file system of the computer can read. Avoid special characters. Mixed capitals and lower case letters are accepted by the Titroprocessor 796; however, this may cause problems with other file systems.  
Each file can be provided with a comment of max. 50 characters which appears in the selection list of the file dialog window and in the file manager.  
The selection of the memory area can also be made via a selection list. A file can be transmitted or received via an RS232 interface. These special functions are described in the file manager section.
- [Determ. report]** In addition to or instead of the mode report of titrations or measurements a report of a complete determination can be defined. This is particularly recommended when several titration or measuring modes have been programmed in a single method. Determination reports form introductory and concluding report blocks as part of the complete report. Between these the individual mode reports (see **[\*Report]** softkey below) are listed. Detailed descriptions of the definition of determination reports are given below.

<b>[ * Param ]</b>	Titration and measuring modes have extended sets of parameters for setting control parameters, etc. These are accessed via this softkey. Descriptions of each setting can be found under command references, page 127ff.
<b>[ *Formula ]</b>	Titration and measuring modes allow different calculation formulas valid for the particular mode to be used. The formula editor is described in section 7.10 (Titration and measuring modes), page 118ff.
<b>[ * Report ]</b>	Titration and measuring modes can contain various report blocks which only apply to that particular mode. These mode reports form individual parts of the full report and appear between the introductory (start) determination report and the concluding (end) determination report. A description of the report editor is given in section 7.11 (Titration and measuring modes), page 123ff.
<b>[Insert line]</b>	inserts an empty command line in front of the current line.
<b>[Delete line]</b>	deletes the current command line. The field cursor must be in the command column.
<b>[ &gt;&gt; &gt;&gt; ]</b>	shows the second softkey bar.
<b>[Copy line]</b>	copies the current command line in into a local buffer.
<b>[Cut line]</b>	copies the marked command into a local buffer and deletes the current command line.
<b>[Paste line]</b>	takes the copied command from the local buffer and inserts it in front of the current command line.
<b>[ &gt;&gt; &gt;&gt; ]</b>	shows the first softkey bar.

#### 5.2.4 Determination report

---

Determination report blocks can be defined as parts of the full report; they can either be produced at the start of a determination or at the end of a determination. In addition, reports can be defined which are produced at the end of a determination when the capacity of the statistics counter is reached.

Determination reports cannot only be printed out but can also be transferred directly to a PC database such as the Metrohm software **VESUV 3**.

The definition of the determination report is made in the report window of the method editor after pressing the [**Determ. report**] softkey.

Determ. report									
	initial	print	send	FF	final	print	send	FF	
Determination reports	Commands	yes	no	no	FullRes	yes	no	no	
		no	no	no	SmplData	yes	no	no	
		no	no	no		no	no	no	
Reports to be printed on full statistics counter					FullStat	yes	no	no	
						no	no	no	
						no	no	no	
					Print signature line	yes			
					Final form feed	yes			
									QUIT

The reports are printed out in the defined sequence. The report blocks defined in the 'initial' column are printed out at the start of the determination, those in the 'final' column when the determination is finished. In the lower half of the edit window the reports which depend on the status of statistics function are defined. These are only produced when the statistics counter is full.

Type	Type of report
initial:	<i>Commands</i>   <i>ComnVars</i>   <i>FormFeed</i>
At the start of a determination reports can be produced which contain the data or settings which are used in the determination.	
<i>Commands</i>	commands in the method (without *Param)
<i>ComnVars</i>	current common variables at start
<i>FormFeed</i>	page feed at printer

Type	Type of report
final:	<i>Standard</i>   <i>FullRes</i>   <i>ShrtRes</i> <i>SmplData</i>   <i>ComnVars</i>   <i>Commands</i> <i>FormFeed</i>   <i>FullStat</i>   <i>ShrtStat</i>
At the end of the determination reports are produced which contain the data obtained during the determination. If several modes have been carried out then the reports include the data of all modes.	
<i>Standard</i>	standard report
<i>FullRes</i>	full results report, detailed
<i>ShrtRes</i>	short results report, minimal
<i>SmplData</i>	sample data with sample weight
<i>ComnVars</i>	common variables at start
<i>Commands</i>	commands in the method (without *Param)
<i>FormFeed</i>	page feed at printer
<i>FullStat</i>	full statistical data report
<i>ShrtStat</i>	short statistical data report

---

<b>print</b>	<b>Report printout</b> <i>yes / no</i>
--------------	---

With 'yes' a report will be printed out on all printers defined in the configuration. This could be both the internal printer as well as an external printer connected to the 'Printer' connection or an RS232 interface.

---

<b>send</b>	<b>Report output via an RS232 interface</b> <i>yes / no</i>
-------------	--

A report can be transferred directly to a personal computer via an RS232 interface. The particular RS232 interface to which the receiving instrument is connected must have been defined as being the communication interface in the interface configuration and the data transfer mode '**LIMS**' must be switched on. Take care that the transmission parameters (baud rate, etc.) of the receiving instrument are set to the same values as on the Titroprocessor 796.

---

<b>FF</b>	<b>Page feed (form feed) at printer</b> <i>yes / no</i>
-----------	--

For formatting the printout of several report blocks it is possible to provide each individual report with a following page feed. A 'Form Feed' only affects the printer. Please note that the internal thermal printer will only carry out a form feed if '**Enable auto FF**' is switched on in the configuration of the interfaces.

---

<b>Print signature line</b>	<b>Operator name and signature line</b> <i>yes / no</i>
-----------------------------	--

A signature line with the operator's name can be printed out at the end of the complete report.

---

<b>Final form feed</b>	<b>Page feed after last report line</b> <i>yes / no</i>
------------------------	--

If reports are to be printed out on a page-oriented external printer (inkjet printer, laser printer) then a form feed must be carried out after the last report in order for the final page to be ejected.

**Note:**

A method is always edited directly in the working memory.

- It is possible to alter command parameters (including titration and measuring modes) while a determination is being carried out. The Titroprocessor 796 will try to use the altered settings as soon as possible. Alterations to the parameters of a command which is not currently being carried out will be taken into account during the same method run. If titration or measuring modes are being carried out this depends on the parameters which are altered.

**Live-Parameter**

In principle virtually all settings can be altered 'live'. Exceptions to this include the allocation parameters (measuring inputs, dosing devices), parameters which directly influence the volume increments or the inclusion of additional measured quantities in the measuring point list (or their elimination).

- The command sequence itself cannot be altered 'live', i.e. no new commands can be inserted while a determination is being carried out, nor can existing commands be deleted or altered.
- During a series of samples a new method can be loaded into the working memory automatically by means of an appropriate entry in the sample silo. However, this is not possible if alterations are being carried out in the method editor at the same time, as the same memory areas are used as are being overwritten by the new method. Avoid editing methods when a series of samples is being processed.
- During the production of a determination report the method name is mentioned in the header together with an attribute which informs about whether the data have been created by newly created, unstored method [n], a loaded modified method [m] or a loaded unaltered original method [o].
- In the footer information is given about whether the determination data are unaltered (original data) or have been re-evaluated or recalculated (modified data).

Example of a determination report:

Instrument name

Program version

---

METROHM Titroprocessor 796 0108 5.796.0012

---

Method 3455.mth [m] ← Method name with attribute [modified]      Method comments → Assay

---

Initial reports

---

Commands

t/s	Commands	Parameters	Parameters
1	MEAS_PH*	pH measurement Sensor 6.0232.100 Meas. input A1 Temperature 25.0 °C	Signal drift 50 mV/min Equilibr.time auto s
2	SHOW	Page	Curve
3	DET_PH*	Assay Reagent HCl Concentr. 0.1 mol/L Dos. drive A1	Sensor 6.0232.100 Meas. input A1
4	SHOW	Page	Result
5	END		

Initial report

...

any mode reports

...

Final report

---

Final reports

---

Standard report

Run number : 001

Method	Sample no.	Lot	Product no.	Size	Unit
HCl	971120/1	12	3455	15.15 g	
Remark					
Sampling 12.11.97					

---

#	Command	Parameters	Parameters
# 1	MEAS_PH*	pH measurement	
	IM	pH 10.435	pH value 10.44
	CM	pH 10.440	
# 4	DET_PH*	Assay	
	EP1	pH 7.198      4.697 mL	Assay 98.95 %

Short statistics

Comment	Formula	Mean	S.dev +/-	Unit	s in %	n
pH value	R1	9.81	0.112		1.58	2
Assay	R2	98.85	0.250 %		0.22	2

Original data      Determ. time: 1997-11-25 13:07:58

File name DATA.002      971120/1 12 HCl      Sampling 12.11.1997 ← File comments

=====

printed: 1997-11-25 13:09:51

User: B. Miller      Signature: .....

Signature line

## 5.3 Determinations

A method can be used to carry out a determination on a sample which can include up to five titration or measurement modes. Each of these modes can contain separate calculation formulas and report definitions. Each mode produces its own data records (measuring point lists). These form the basis of all reports and graphs. The complete report of a determination comprises determination reports together with reports of the individual titrations or measurements.

The data produced during a determination are stored in a file which can be stored automatically in the internal memory or on a data card. It is also possible to transfer the determination data directly via an RS232 interface as a raw data report to a suitable PC database such as Metrodata **VESUV 3** or to store the whole file on a PC. Determination files can be comfortably copied, renamed or deleted with the file manager.

Existing determination data can be subsequently re-evaluated and recalculated without any problems and without having to load the original method.

### 5.3.1 Carrying out a determination



A determination is started with the **<START>**key. The defined start report is printed out first.

The method is then processed line by line. As soon as an **END** command is reached the determination will be terminated properly. The determination data are stored in a file and the final report is printed. If the autostart function has been switched on the next determination will be started; otherwise the Titroprocessor 796 will return to the normal state.



A determination run can be interrupted with the **<HOLD / CONT>**key. The determination can be continued by pressing the **<HOLD / CONT>** key again. In the **'Hold'** condition the Titroprocessor can be operated normally. The ('Live') parameters of the method can be edited. The various peripheral devices can be operated manually provided that they not blocked by the determination. This is a particular advantage when a sample changer is being used. The determination can also be completely terminated in the **'Hold'** condition with the **<STOP>** key.



A running determination can be terminated at any point with the **<STOP>**key. The necessary termination operations are carried out just as in a regular determination. The type of determination termination is mentioned in the results report (e.g. termination condition *'manual'* or *'regular'*).

If the autostart function is switched on pressing the **<STOP>** key will terminate the complete series of samples.



If in a determination run containing several commands the execution of the currently active command is to be interrupted and a jump made to the following command in the method then this can be carried out with the **<SKIP>**key by pressing the key combination **<↑><HOLD / CONT>**.

**Warning:** during the start phase of a titration only the addition of the initial volume is terminated with the **<SKIP>** key. The titration will nevertheless be carried out normally.



When a sample series is being processed with the autostart function switched on the series can be interrupted without terminating the determination currently being carried out. With the help of the **<DELAY>** key (key combination **<↑><STOP>**) the sample series will be interrupted when the current determination has been finished. The Titroprocessor returns to the normal state and the autostart counter is stopped.



In a sample series the current determination can be stopped with the **<NEXT>** key (key combination **<↑><START>**) and the sample series continued with the next determination .

Various entries can be made and settings altered while a determination is being carried out. In particular, sample data can be entered via the keyboard, from a balance or via a barcode reader. This is possible both for individual determinations on the main page as well as for series of samples in the sample silo.

### 5.3.2 Individual determinations

In order to carry out a simple individual determination the following settings must be made:



- Load a method into the working memory by pressing either the **<METHOD>** key on the keyboard or the **[Load method]** softkey.

[Load method]

The method selection window could be similar to that shown below.

- Use the cursor keys to select a method from the method list (internal memory / data card) and press the **<ENTER>** key.

[→][←]  
[↓][↑]

Method	
File	Comment
Methods on data card	
NaOH.mth	Titer of NaOH
HCl.mth	Titer of HCl
Iodine.mth	Iodine determination
Chloride.mth	Determination of chloride
Sulfate.mth	photometric sulphate determination
CaMgTap.mth	Calcium / Magnesium in tap water
Hardness.mth	total water hardness by photometric titration
Acidcapa.mth	acid capacity in tap water
Tapwater.mth	Total water hardness
ClinTap.mth	Chloride in tap water
BlankS04.mth	Blank determination for sulphate in water
Sulphate.mth	Sulphate in water samples

Press <Enter> to load method

QUIT

[ENTER]

The method is loaded and the application note displayed on the main page. This can contain information for the operator, e.g. instructions for sample preparation .

```

1997-11-27 10:17:52      MAIN PAGE 796 Titroprocessor      * ready *
Method      ClinTap.mth      Chloride in Tap Water
-----
User      B. Miller      Application Note
      Chloride in Tap Water
      Pipet 100.00 mL tap water exactly in a
      150 mL beaker.
Sample      Ident1      Ident2      Ident3      Size      Unit
Remark
Config.  Load  File  Edit  Show  Results  Sample  Card  Common
method  method manager  method  curves  silo  Sign on  vars

```

- Enter your name in the '**User**' field.
- Now enter the status settings. The status window can be called up from any dialog page with the <**STATUS**>key.



```

Status
Run number      000      Determination name  00022115.403
Sample silo      off
Auto start      off
Statistics      off
Save determ. data  off
Sample changer
QUIT

```

Take the standard settings for the simplest form of an individual determination from the above diagram. If your instrument has different settings then correct them or adapt them to your requirements.

**Run number** sequential sample number; set the required initial value – 1.

**Statistics** with '**on**' the required number of determinations will be kept in the working memory and statistics calculations will be possible.

**Auto save** with '**on**' each determination will be copied automatically from the working memory to the predefined storage area.

**Destination** memory area for automatic storage of determinations, see above.

<b>Determ.name</b>	the file name of the current determination appears here.
<b>Auto start</b>	single determinations or automatic sample series; set ' <b>off</b> ' for single determinations.
<b>Silo</b>	on/off switch for sample silo; set ' <b>off</b> ' for single determinations.
<b>Changer</b>	address of sample changer used; no entry is required for single determinations.

- Now prepare the sample.



- Enter the sample data. This can be done directly in the main page of the Titroprocessor or by calling up the sample window with the <SAMPLE> key.

Current Sample					
	Ident1	Ident2	Ident3	Size	Unit
Sample					
Remark					

QUIT

The sample data can be entered manually. It is also possible to accept the sample weight and units directly from a balance .

Sample data can also be entered while a determination is being carried out ; however, this must be done before the calculations have been completed, i.e. before the titration or measurement has been completed in which the sample weight is to be used for calculation.

For automatic data transfer from a balance it is not absolutely necessary that the main page or the sample window is visible. The incoming sample data are received by the RS232 interface, interpreted and filed on the main page or – if switched on – in the sample silo. Even after the determination has been carried out it is still possible to enter new sample data for the recalculation of the results.

If sensors and dosing devices have been correctly connected (see installation pages 23 and 26 the dosing devices can now be prepared for the determination.

To profit from the full accuracy of your dosing devices, cylinders and tubings must be rinsed before each use or at least once per day. This eliminates gas bubbles that may form in the dosing cylinder if the Dosino is not used for a longer time interval.

Use the **PREP** function regularly.

- Press the **<MAN CONTROL>** key in order to be able to operate the dosing device manually.

```

Devices & Manual Control
-----
Dosing devices at interface A                               press <TAB> for more
Dos. drive          A1          700          A2          685          A3          ---          A4          ---
Reagent
Concentr.
Tubing              Default          Default          Default          Default
Buret type          10.0mL          10.0mL          ---          ---
Piston position     exchange          exchange          ---          ---
Dosing status       ready          ready          ---          ---

Sensors at interface A                                   press <TAB> for more
Meas. input        A1          A2          Adiff          AT
Sensor
Cal. sensor
Cal. method
Cal. date
Next calibr.
pH(as)              7.000          7.000          7.000          Stirrer on
Slope               1.000          1.000          1.000

----- QUIT

```

Sample changer	Fill all	Fill	Prepare buret	Dosing drive	Empty	STOP	STOP all	Remote lines
----------------	----------	------	---------------	--------------	-------	------	----------	--------------

Check the settings of the connected dosing device on the '**MANUAL CONTROL**' page. If no entries have been made under 'Reagent' and 'Concentr.' then no reagent check will be carried out. If different reagents are often used this is probably the correct setting, otherwise please see page 54.

If the buret of the connected dosing device is equipped with the standard tubing (dosing tubing 400 x 2 mm, ...), then '**Default**' must be entered under **Tubing**. If the buret unit is not equipped with standard tubing then it must be configured accordingly, see page 47ff.

[→][←]

- Use the cursor keys to select the required dosing device, make sure that the buret tip of the attached buret unit is located in a rinsing beaker and press the **[Prepare]** softkey.

**[Prepare]**

All the tubing and the cylinder of the buret unit are now rinsed with a sufficiently large amount of reagent to ensure that the buret unit is properly filled without any air bubbles.

- After the sensor and the buret tip have been rinsed with a suitable solvent the Titroprocessor is set up and the sample can be positioned. Press **<QUIT>** to return to the main page of the Titroprocessor.
- The **<START>** key can now be used to start the determination.

### 5.3.3 System variables

A determination produces the following system variables which are available for calculations :

<b>MNR\$\$</b>	mean value of the results <b>R\$\$</b> in statistics memory
<b>MNX\$\$</b>	mean value of the intermediate results <b>X\$\$</b> in statistics memory
<b>MNC###</b>	mean value of the common variables <b>C###</b>
<b>ID1</b>	sample identification 1 (only numerical entries)
<b>ID2</b>	sample identification 2 (only numerical entries)
<b>ID3</b>	sample identification 3 (only numerical entries)
<b>SS</b>	sample size (without units)
<b>DD</b>	determination duration in s
<b>\$RN</b>	sample number
<b>\$AS</b>	autostart counter
<b>\$BC</b>	buffer counter

### 5.3.4 Determination files

Data produced during a determination are stored in a file in the working memory while the determination is proceeding. The name of the determination file and (optionally) file comments belonging to it are created automatically according to the settings on the configuration page. Various masks with combinations of determination time, sample number or sample identifier, etc. are available, see page 35f.

If the statistics function is switched off (see below) the file of the current determination will always be kept in the working memory until a new determination has been started.

After the start of a determination the determination data (results, curves, etc.) of the previous determination are no longer contained in the working memory. The current determination file in the working memory cannot be deleted and remains in existence – just like the current method – even when the instrument is switched off. An exception to this is the initialization of the statistics function, see below.

#### Statistics function

If the statistics function is switched on then the statistics counter limit determines the number of the determination files which can be present in the working memory (**Statistics 'on' 1 of '10'** => max. 10 files in the working memory). Up to 20 determination files can be contained in the working memory.

If during a sample series the statistics counter becomes filled up with the number of determinations carried out then at the start of the next (surplus) determination the statistics will automatically be initialized again. This means that the working memory will be completely emptied and can start to be filled up again with the following determinations.

The statistics can be initialized manually and in this way the working memory (together with the current determination) can be totally cleared. This process is recommended before a sample series is carried out. Select **Statistics 'rst'** on the main page (this is not possible in the status window).

### Auto save function

With the aid of the auto save function (**Auto save 'on'**) determination files can be automatically stored in the internal memory, on a data card or (via an RS232 interface, see page 229) on a personal computer. Always make sure that sufficient memory space is available for this.



If the auto save function is used then care must be taken that only unambiguous and different file names are created. If an attempt is made to overwrite an existing determination file with one with the same name the safety query which this produces will interrupt the processing of the sample series. Use the possibility of combining date, time and/or sample number for the automatic creation of file names, see page 35f.

A typical determination which includes a titration requires approx. 5 - 10 KB memory. The file manager can be used to determine the amount of free memory in the internal memory or on a data card.

The file manager can be used to copy determination files at a later date or to copy them onto a data carrier from the results window.

### Determination data

The contents of a determination file also includes, apart from the measuring data produced (measuring point lists of the titrations and measurements,) the settings and parameters which are required for a re-evaluation together with additional information which is used for a GLP-conform presentation of the determination. Details can be found in the table below.

File name + File comments + File attribute		
Method name with attribute		
(local) Common variables + System variables		
Sample data + Operator name		
#1 Mode	#2 Mode	Up to 5 Modes
System variables	System variables	...
Measuring point list	Measuring point list	...
Evaluation and presentation parameters	Evaluation and presentation parameters	...
Formulas	Formulas	...
Report definitions	Report definitions	...
Calibration data	Calibration data	...
Results	Results	...
Error list	Error list	...
Report header + Determination report definitions		
Instrument identification		
Date of determination		

**5.3.5 Sample series**

If a sample series is to be carried out automatically then the corresponding method should be loaded in the way described for single determinations on page 80.

In addition the following status settings should be made in the status window (press <STATUS>key):

- Statistics on** for statistics calculations and/or re-evaluations; increases the working memory for the given number of determinations.
- Auto save on** the original determination data are stored in a permanent memory.
- Destination ...** depending on the memory requirements a corresponding memory area can be selected.  
**Warning!** The internal memory is limited to 1.5 Mbytes and if used to the full can impose limits on the working memory.
- Auto start on** switch the autostart function on and enter the number of samples. Not just a numerical value can be entered.  
\* = indefinite number, infinite series  
**Silo** = the complete sample silo will be processed from the indicator marker onwards.  
**Rack** = The whole of the sample rack on the sample changer will be processed. \*
- Silo on** unconditionally recommended for sample series. Enter the sample data in the sample silo first, set the start marker there and switch the silo on.
- Changer 1** the address of the sample changer used.
- Sample pos. 1** rack position of the first sample

With '**Auto start Rack**' the method used should be optimized in order to ensure that the last determination in the sample series is carried out correctly.

Insert the following two lines at the end of the method, but **before** the definition of the closing sequence (**CMOVE**):

```
SAMPLE      Function      + Value      1
MOVE_S      Sample to tower  1
```

The status window should be similar to that shown below:

Status			
Run number	000	Determination name	00012115.403
Sample silo	on	Next sample	in silo line 1
		Sample entry	in silo line 11
Auto start	on	Current sample	0 of 9999
Statistics	on	Data records	0 of 10
Save determ. data	on	Destination	Internal
		Free Memory	93.9 %
Sample changer	1	First rack position	1

QUIT

**[Sample silo]**

- To enter the sample data open the sample silo with the **[Sample silo]** softkey of the <SAMPLE> key.

Sample silo : NEW.slo

#	Method	Ident1	Ident2	Ident3	Size	Unit
<> 1						
2						
3						

- Now enter the sample data line by line. This can be done manually or the sample weight can be transferred directly from a balance. In the latter case the sample identifiers can be entered later by hand.
- If the necessary method has already been loaded then leave the 'Method' column empty. An entry would have the effect that before the silo line involved is processed the given method is loaded into the working memory.
- Further details about editing the sample silo can be found on page 92ff.
- In order to indicate which sample should be processed place the field cursor on the line containing the sample data of the first sample. Press the **[ >> >> ]** softkey to display the second softkey bar. Use the **[<-- Out pointer]** softkey to set the silo output marker. This always marks the next silo line to be processed with the '<' character. It is carried out again for each determination.

#	Method	Ident1	Ident2	Ident3	Size	Unit
< 1		971120/1	12	3455	100	mL
2		971120/1	12	3455	100	mL
3		971120/2	15	3455	100	mL

- If subsequently – possibly even as the sample series is being processed – further sample data are to be transferred from the balance to the Titroprocessor then set the silo input pointer to the next free silo line. This is carried out in a similar way to setting the silo insert pointer (softkey **[--> In pointer]**). The insertion mark '>' is moved on by

one line each time sample data are inserted.

9		971120/5	25	3455	100 mL
10	>	971120/5	25	3455	100 mL
11					
12					

- Now prepare the sample changer with the sample beakers. Place the sample beakers on a sample rack and place this on the sample changer. The sample changer will automatically recognize which rack is in position when it is initialized. This is done by pressing the **<MAN CONTROL>** key on the Titroprocessor and then the **[Sample changer]** softkey.
- Initialize the sample changer by pressing the **[Reset]** softkey. This should be carried out each time a sample rack is exchanged. After the sample changer has moved to its starting position the correct rack name should be shown in the sample changer dialog window. If this is not the case then the sample changer and the rack definitions must first be configured, see page 39ff.

```

Devices & Manual Control
┌───────────┴───────────┐
│ Sample changer        │
├───────────┬───────────┤
Do |          |          |          |          |
   | Changer  |          | 1: ready | [000001] |
├───────────┴───────────┤
Do |          |          |          |          |
   | Rack type/name | M12-0 - 12*250mL |
Re |          |          |          |          |
Ko | Max. beaker   |          |          |          |
   |          |          |          |          |
   |          |          |          |          |
└───────────┬───────────┘

```

- Now use the softkeys **[Shift left]**, **[Shift right]**, **[Lift up]** **[Lift down]** to rotate the sample rack so that a rinsing beaker is positioned under the titrating head which has been fitted up. Please note that the rack can only be rotated when the lift (or both lifts for models with two lifts) is located in the upper rotate position defined in the configuration.
- Move the lift to the working position and prepare the buret units as described under 'Single determinations ' (page 83).
- The entry **'Sample pos.'** can be found on the main page. This determines the first rack position in the sample series. The beaker position which contains the first sample should be entered here. This must not necessarily be position 1.
- Initialize the statistics (**Statistics 'rst'**) in order to clear the working memory and create enough space for the determination data of the sample series.
- All necessary settings have now been made. Press the **<START>** key to start the sample series.

### 5.3.6 Course of a sample series

The following points should be taken into account before starting a series:

- Check whether all sample beakers have been placed on the rack correctly. It is absolutely necessary that the beaker containing the first sample of the series is present. Other sample beakers can be added as the series is being processed.
- After the start of the sample series the necessary storage space is reserved in the working memory according to the settings under '**Statistics**'. If not sufficient storage space is available the process will be interrupted.
- During the first determination of the series command sequence defined in the methods of the **OMOVE (... )OMOVE** loop will be carried out a single time.
- In the following determinations in the series the neither the **OMOVE (... )OMOVE** nor the **CMOVE (... )CMOVE** loops will be carried out (see below).
- In the last determination in the sample series the **CMOVE (... )CMOVE** loop defined in the method will be carried out.

These start and closing sequences are provided specially for sample changer operation and can be used e.g. for conditioning or regenerating sensors. For these applications the use of special beakers on the sample rack is a good idea (see configuration, page 42).

#### Course of a sample series

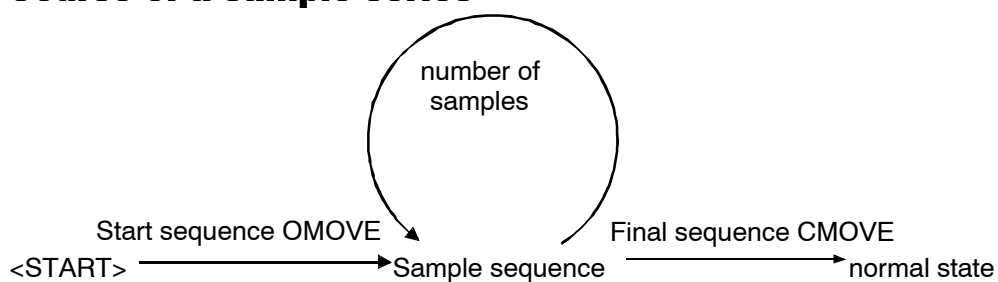

It is not absolutely necessary these start and closing sequences (OMOVE/CMOVE) are defined at the start or end of a method. However, please note that the method is processed strictly according to the sequence of defined command lines.

### Statistics and sample series

In certain cases it may be a good idea to set the statistics limit to a lower value than the total number of samples. If double or triple determinations are to be carried out on the same sample within a sample series and statistical data are to be calculated for each of them then the statistics limit should be set to 2 or 3 respectively.

The statistical calculations are carried out for each sample but with these settings the statistics are reset after each 2 or 3 determinations and the working memory cleared. In this way statistical calculations are obtained for double or triple determinations.

**Warning!** Statistical results are only calculated according to formulas which have been defined as a 'Statistics formula' (formula type '**stat.**') in the formula editor. The statistics should be initialized before the start of a sample series.

## 6 Sample data and sample silo

---

A data record can be entered for each sample. This data record contains:

- Sample identifiers (Ident1, Ident2, Ident3)
- Sample weight and units
- Comment line

For identification simple descriptive texts or numerical values can be used; the numerical values can be used in calculations (system variables **ID1**, **ID2**, **ID3**). The names and the type of field (text, numerical, auto) can be altered to suit your requirements, see page 97.

The comments line can be used for clearly specifying a sample and can be used for the creation of automatic file comments (see page 35f).

The sample weight is normally used for calculations (system variable **SS**). It can be entered manually or from a balance via the RS232 interface(s) even while a determination is taking place. It is additionally possible to enter all sample data with a barcode reader.

### 6.1 Sample data entry

There are several different ways of entering sample data:

#### For single determinations (Silo 'off')

- Manual input in sample data section of the main page of the Titroprocessor.
- Manual input in the dialog window '**Current sample**', with the **<SAMPLE>** key on the keyboard.
- Manual input with the command '**ASK**' during a determination run, see page 207f.
- Automatic data input with data transfer from a balance.

#### With sample series (Silo 'on')

- Manual input in sample silo.
- Automatic data input in sample silo by data transfer from a balance.

#### 6.1.1 Direct data transfer from balances

---

Most balances used in laboratories allow the sample weight (and units and sample identification, depending on the model) to be transmitted directly to the Titroprocessor via an RS232 interface. This receives the data in a special data buffer and interprets the transmitted data according to the balance type set.

In this way it is possible to enter the sample data at any time (even while a determination run is being carried out) correctly in the current sample data record or in the sample silo.

A precondition for this is the correct definition of the type of balance and the correct setting of the data transmission parameters in the Titroprocessor configuration (page 44).

Consult the manual of your balance and make sure that the sample data from the balance are transmitted with the line limit characters **CR** and **LF** and that the data transmission parameters (baud rate, etc.) agree with those of the Titroprocessor.

For further details please see page 27f.

### 6.1.2 Bar-code reader

---

A bar-code reader can be used wherever the manual input of data is possible. This is connected to the 'Barcode' socket on the rear panel of the Titroprocessor. Intelligent bar-code readers recognize the type of bar-code automatically and convert it into an ASCII character sequence which the Titroprocessor accepts as if it had been entered via the keyboard. Please consult your local Metrohm agency.

See also pages 30 and 289.

## 6.2 Sample silo

The sample silo is a table consisting of 160 lines for accepting the data of a sample series. It is selected by pressing the [**Sample silo**] softkey on the main page or the <SAMPLE>key (with silo 'on').

- The whole sample silo can be deleted with [**File**] and [**New**].
- An empty sample silo consists of a single line. New lines are created by pressing the key combination <↑><↓> (shift – cursor).
- In principle the contents of the sample silo remains in existence when the individual silo lines have been processed. Individual lines can be marked ([**Un/Mark**]) softkey and deleted with the [**Delete line(s)**] softkey.
- The contents of the sample silo can be stored and (with the [**File**] softkey) can be read in again from the internal memory, from a data card or even from a PC via an RS232 interface (see page 229). Product-specific sample silos can also be created and copied to several Titroprocessors.

Sample Silo : NEW.slo

#	Method	Ident1	Ident2	Ident3	Size	Unit
<> 1		19991220/2	B5	3455	100	mL
2						
3						
4						
5						
6						
7						
8						
9						
10						
11						
12						
13						
14						
15						
16						
17						
18						
19						

QUIT

Remark	File	Un/Mark	Insert line	Copy line(s)	Delete line(s)	Un/Mark all	Edit mode	>> >>
--------	------	---------	----------------	-----------------	-------------------	----------------	--------------	----------

The normal view shows the sample data line by line. By pressing the **[Remark]** softkey a descriptive note can be entered for each silo line (or sample), which will be printed out in a report as a part of the sample data. The **[Sample silo]** softkey returns the display to the standard view.

Sample Silo : NEW.slo

#	Remark
<> 1	Sample of 12/20/1999
2	
3	
4	
5	
6	
7	
8	
9	
10	
11	
12	
13	
14	
15	
16	
17	
18	
19	

QUIT

Sample silo	File	Un/Mark	Insert line	Copy line(s)		Un/Mark all	Edit mode	>> >>
----------------	------	---------	----------------	-----------------	--	----------------	--------------	----------

**The individual silo columns:**

<i>Pointer column</i>	<p>The output pointer '<b>&lt;</b>' marks the next line to be processed.</p> <p>The input pointer '<b>&gt;</b>' marks the next line in which sample data from a balance can be entered.</p>
<b>#</b>	Line number
<b>Method</b>	Method which can be loaded from the internal memory or from a data card to process the sample. No entry means that the method which is currently loaded in the working memory will be used. A selection list of the available methods is available for this input field (in the internal memory). The names of the methods on a data card must be entered manually.
<b>Ident1...3</b>	Sample identifiers. The type of input field can be configured for each column (softkey <b>[ Probenident. ]</b> )
<b>Size</b>	Sample size
<b>Unit</b>	Sample weight unit. The fields in this column have a selection list available.

**Softkeys**

---

<b>[ Remark ]</b>	switches the dialog window to the view of the sample notes in the silo lines.
<b>[ File ]</b>	opens the file dialog window for loading and storing silo files.
<b>[ Un/Mark ]</b>	marks or removes the markers from individual silo lines for copying or deleting.
<b>[ Insert line ]</b>	inserts an empty silo line in front of the current line.
<b>[ Copy line(s) ]</b>	copies the marked silo lines and inserts them in front of the current line.
<b>[ Delete line(s) ]</b>	deletes the marked silo lines. If no line has been marked then the current line will be deleted.
<b>[ Un/Mark all ]</b>	marks or removes the markers from all silo lines.
<b>[ Edit mode ]</b>	opens the dialog window for setting the edit mode.
<b>[ &gt;&gt; &gt;&gt; ]</b>	switches to second softkey bar.

[<-- <b>Out pointer</b> ]	sets the output pointer '<' to the silo line selected with the field cursor.
[--> <b>In pointer</b> ]	sets the input pointer '>' to the silo line selected with the field cursor.
[ <b>Copy line</b> ]	copies the silo line selected with the field cursor into the local buffer memory.
[ <b>Cut line</b> ]	copies the silo line selected with the field cursor into the local buffer memory and deletes the current line.
[ <b>Paste line</b> ]	inserts the contents of the local buffer memory in front of the current silo line.
[ <b>Sample idents</b> ]	opens the dialog window for defining the sample identification column.
[ >> >> ]	switches to the first softkey bar .

### 6.2.1 Sample silo configuration

The edit mode of the sample silo can be configured. This is done by pressing the [**Edit mode**] softkey.

```

Edit mode
AutoCopy      on
Edit direction line
QUIT

```

- If during data input the total contents of a silo line are to be copied into the next line at the end of each line then the automatic copying function should be switched on (**AutoCopy 'on'**).
- The sample table can be worked on line by line or column by column. Select **Edit direction 'line'** or '**column'**.

Settings which differ from the standard settings are shown in the sample table frame.

```

copy; column  QUIT
Un/Mark | Edit | >>
         | mode | >>

```

### Sample identification

The sample identification names and types of field can be configured with the [**Sample idents**] softkey in the second softkey bar. These definitions are also saved when a silo file is stored and can be reloaded with the silo contents, see page 95.

#### Field types:

- auto**            an entry is automatically interpreted as numerical or as text.
- text**            an entry (even numerical) is always accepted as being text and thus cannot be used in any calculations.
- numeric**        an entry is always interpreted as being numerical and can thus be used in calculations. (System variables ID1, ID2, ID3). In this type of field the input of text is not accepted.

Sample silo: Sample idents	
Name	Field type
Ident1 Sample no.	auto
Ident2 Origin	Text
Ident3 Analysis	numer.

QUIT

This produces the following type of sample silo.

#	Methode	Sample no.	Origin	Analysis	Size	Unit
<> 1		971120/2	B5	3455	100	mL

If on the main page of the Titroprocessor 796 the silo is switched on then these field definitions for the sample identifiers will be adopted there. Otherwise the definitions from the configuration settings will be used, see page 37.

### 6.2.2 Automatic data input and output

The sample silo is controlled by pointers. The first silo column always shows the current position of the input (>) and output markers (<).

#### Data acceptance from a balance

The input pointer marks the silo line in which the next sample weight will be accepted from a balance (via an RS232 interface).

The input pointer is set by placing the field cursor on the required silo line and pressing the [**--> In pointer**] softkey, which is found on the second softkey bar. The second softkey bar is accessed with the [**>> >>**] softkey.

The input marker (>) is placed on the selected silo line in this way. If sample data are to be transmitted from a balance then the data are inserted into the marked silo line and the marker moves downwards by one position.

### Data output in the current sample data

The output pointer (<) marks the silo line which will be used for the next determination in a sample series. The output marker is set in the same way as the input marker (Softkey [**<--Out pointer**]).

In order to process a sample series the sample data must first be entered in the sample silo. Place the output marker on the silo line with which the sample series is to start.

The number of samples or silo lines to be processed can be set in the status window (<**STATUS**> key) or on the main page with the option '**Auto start**'. Not only a number can be entered. The entry '**Silo**' has the effect that all silo lines after the output marker will be processed.

The method which is to be used for one or more particular samples can be defined in the method input field of each silo line. The specified method is loaded into the working memory before the affected line(s) are processed and carried out with the sample data of the current silo line. If this possibility is used then no alterations can be made to the particular methods loaded while the sample series is being processed. An open method editor prevents another method from being loaded.

If no method has been specified then the current method in the working memory will be used. When a determination has been completed the sample data remain in the sample silo but the output marker is moved downwards by one position.

## 7 Titration and measuring modes

---

### 7.1 General

The 796 Titroprocessor carries out all the individual titration processes automatically and controls them itself. The various individual steps can be varied to a large extent and adapted to the specific requirements of an analysis. The titration and measuring modes of the 796 Titroprocessor have been optimized for various applications.

A list is given below of the various aspects of a mode together with the corresponding variants:

#### Reagent addition

- incremental reagent addition with constant volume steps
- incremental reagent addition with dynamically variable volume steps
- regulated, drift-controlled reagent addition

#### Measuring system

- potentiometric ion measurement with combined sensors or separate measuring and reference electrodes
- calibration of potentiometric measuring systems
- (bi)amperometric indication by means of a polarized electrode and pre-selected polarization voltage
- (bi)voltametric indication by means of a polarized electrode and pre-selected polarization current
- temperature measurement with a Pt100 or Pt1000 sensor

#### Titration control

- titration with automatic recognition of inflection point / equivalence point
- titration to a preset endpoint

#### Equivalence point recognition

- selectable criterion for recognition of qualitatively different inflection points / equivalence points
- endpoint window for selective limitation of the equivalence point recognition to selected measuring ranges
- fixed endpoint recognition at pre-selected value

#### Calculations

- freely editable calculation formulas for calculating results
- access to user-defined permanently stored 'common variables'
- use of system variables with detailed data of a titration

### Report printout

- report blocks freely combinable over a wide range for printed output of results and titration curves
- all reports can be transferred to a LIMS via a connected personal computer
- the raw data report allows the seamless transfer of titration data to the Metrohm-specific database VESUV

## 7.2 DET Dynamic equivalence point titration

### Application:

DET modes are universal titration modes which can be used for most (unproblematic) titrations. Their features are a dynamically titration algorithm, variable dosing steps, drift-controlled measurement acceptance and automatic equivalence point recognition.

They also recognize potential jumps which lie close together or which are not very distinct.

**Important:** as the addition of the reagent depends on the measuring data the titration should not vary too greatly from an S-shaped curve.

### 7.2.1 Measuring mode

A dynamic equivalence point titration can be carried out with four different types of measurement:

- potentiometric pH measurement (DET\_PH\*)
- potentiometric voltage measurement (DET\_U\*)
- amperometric measurement with selectable polarization voltage (DET\_UPOL\*)
- voltametric measurement with selectable polarization current (DET\_IPOL\*)

### 7.2.2 Reagent addition and measurement acceptance

The reagent addition and measurement acceptance are very closely related. The optimal size of a dosing increment is always determined by the change in the measurement following the preceding addition. The addition of titrant therefore depends on the slope of the titration curve. After the addition of the particular dosing increment the potential of the sample solution is measured. Acceptance of a measurement in the measuring point list can also take place with controlled drift. In drift-controlled measurement acceptance the measurement drift of the measured potential must be lower than a pre-defined amount for it to be accepted as a valid measurement. If after a defined waiting period has elapsed this measurement drift has not been undercut then the momentary measurement will be accepted and included in the list of measuring points together with the corresponding value for the volume.

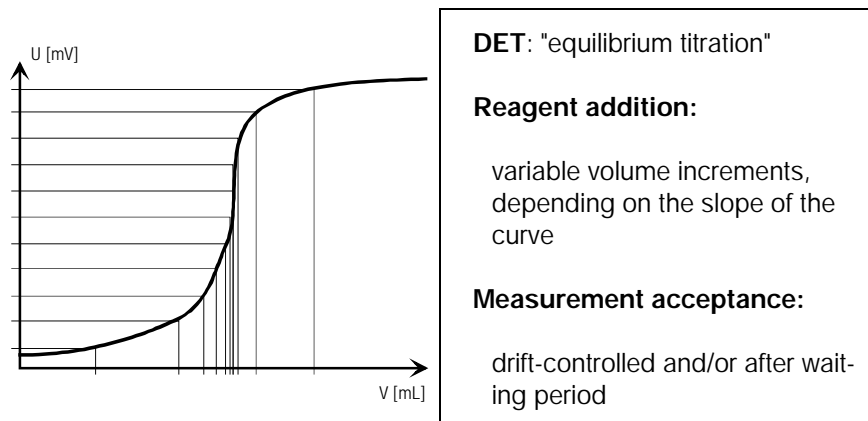

Three predefined sets of parameters, which can be further optimized, are available in the 796 Titroprocessor for setting the titration control.

### 7.2.3 Automatic equivalence point recognition

---

In dynamic equivalence point titration the equivalence points of a titration (i.e. inflection points of the titration curve) are calculated mathematically from the 2nd derivative ( $d^2\text{measurement}/d^2\text{volume}$ ) of the titration curve according to a special Metrohm algorithm which also evaluates overlapping potential jumps correctly.

In order to recognize an equivalence point (**EP**) an auxiliary quantity **ERC** (**E**quivalence point **R**ecognition **C**riterion) is used. In order to avoid interpreting background noise of the measuring signal and unwanted interference signals as being equivalence points an adjustable threshold value can be set for the equivalence point criterion. Supposed EPs which have a smaller equivalence point criterion (**ERC**) than this threshold value will not be recognized as such. The EP criterion **ERC** is obtained from the 1st derivative of the titration curve and combined with a mathematical function which detects flat potential jumps more sensitively than steep jumps. The 796 Titroprocessor can process up to 9 equivalence points.

#### General evaluation range

A common requirement is that the automatic equivalence point evaluation should only be carried out for a limited range of measurements. For this purpose a general upper and lower limit for the required range of measurements for the equivalence point recognition can be set.

If several equivalence points are expected in a titration the EP recognition can be optimized. If only one equivalence point is to be evaluated a selection can be made as to whether the 'largest' (the steepest potential jump) or the last equivalence point should be evaluated.

#### EP window

If several equivalence points are of interest then for each expected **EP** (EP1 to EP9) an EP window with separate equivalence point criterion (**EPC**) can be defined. An EP window is defined by the limiting values of the measurement range within which limits the equivalence point is to be recognized. In a single EP window only one equivalence point can be evaluated. The different EP windows must not overlap.

### 7.2.4 Fixed endpoints

---

Fixed endpoints (F1 to F9) can be set for the determination of a value for the volume for a predefined measurement. This function is advantageous for the application of certain conventional methods; for TAN/TBN determinations, for example, it is even absolutely necessary. For pH titrations the sensor used must have been previously calibrated.

### 7.2.5 Evaluation of pK and HNP values

---

From the data of the titration curve of an acid/base titration the acidic or basic strength of a sample can be determined. For this purpose the **pK** value or the **HNP** value can be determined automatically. The following formula applies:

$$\text{pH} = \text{pK} + \log(a_{\text{B}}/a_{\text{A}})$$

If  $a_{\text{B}} = a_{\text{A}}$ , then  $\text{pH} = \text{pK}$ .

The **pK** value determined is the volume at the half neutralization point, which can be obtained from the titration curve. Careful calibration of the pH electrode used is a precondition for a correct determination of the pK value. In non-aqueous solutions the half neutralization potential (**HNP**) is often used instead of the **pK** value. The **HNP** value is evaluated in the same way as the **pK** value.

---

**The various parameters for the DET modes are described in detail on pages 128 to 142.**

## 7.3 MET Monotonic equivalence point titration

### Application:

**MET** modes are flexible titration modes for titrations which do not provide S-shaped titration curves or for kinetic inhibited titration reactions. Their typical features are constant dosing increments at regular or drift-dependent time intervals and automatic equivalence point recognition.

The equivalence point evaluation is carried out on the basis of the Fortuin method with an optimized evaluation algorithm.

**Important:** reagent addition and measurement acceptance can also be optimally adapted for demanding applications. However, incorrectly selected parameters such as too large volume increments can easily produce imprecise results.

### 7.3.1 Measuring mode

---

A monotonic equivalence point titration can be carried out with four different types of measurement:

- potentiometric pH measurement (**MET\_PH\***)
- potentiometric voltage measurement (**MET\_U\***)
- amperometric measurement with selectable polarization voltage (**MET\_UPOL\***)
- voltametric measurement with selectable polarization current (**MET\_IPOL\***)

### 7.3.2 Reagent addition and measurement acceptance

---

Reagent addition is defined by laying down the size of the constant volume increments and the dosing speed. The addition thus does not have any direct relationship to the measuring behavior.

After the addition of a dosing increment the potential of the sample solution is measured. Acceptance of a measurement in the measuring point list can be drift-controlled or after a fixed waiting period. In drift-controlled measurement acceptance the measurement drift of the measured potential must be lower than a predefined amount for it to be accepted as a valid measurement. If after a defined waiting period has elapsed this measurement drift has not been undercut then the momentary measurement will be accepted and included in the list of measuring points together with the corresponding value for the volume.

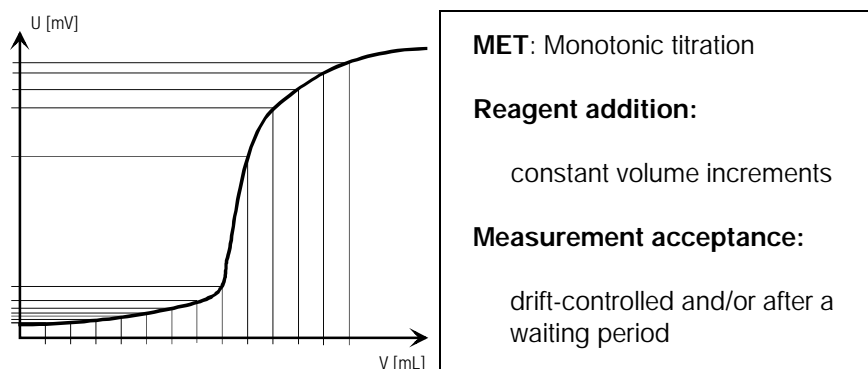

Three predefined sets of parameters, which can be further optimized, are available in the 796 Titroprocessor for setting the titration control.

### 7.3.3 Automatic equivalence point recognition

In monotonic equivalence point titrations the equivalence points of a titration (i.e. inflection points of the titration curve) are evaluated according to Fortuin.

In order to recognize an equivalence point (**EP**) an auxiliary quantity **ERC** (**E**quivalence point **R**ecognition **C**riterion) is used. In order to avoid interpreting background noise of the measuring signal and unwanted interference signals as being equivalence points an adjustable threshold value can be set for the equivalence point criterion. Supposed EPs which have a smaller equivalence point criterion (**ERC**) than this threshold value will not be recognized as such. The EP criterion **ERC** is obtained from the 1st derivative of the titration curve and combined with a mathematical function which detects flat potential jumps more sensitively than steep jumps. The 796 Titroprocessor can process up to 9 equivalence points.

#### General evaluation range

A common requirement is that the automatic equivalence point evaluation should only be carried out for a limited range of measurements. For this purpose a general upper and lower limit for the required range of measurements for the equivalence point recognition can be set.

If several equivalence points are expected in a titration the EP recognition can be optimized. If only one equivalence point is to be evaluated a selection can be made as to whether the 'largest' (the steepest potential jump) or the last equivalence point should be evaluated.

#### EP window

If several equivalence points are of interest then for each expected **EP** (EP1 to EP9) an EP window with separate equivalence point criterion (**EPC**) can be defined. An EP window is defined by the limiting values of the measurement range within which limits the equivalence point is to be recognized. In a single EP window only one equivalence point can be evaluated. The different EP windows must not overlap.

### 7.3.4 Fixed endpoints

Fixed endpoints (F1 to F9) can be set for the determination of a value for the volume for a predefined measurement. This function is advantageous for the application of certain conventional methods; for TAN/TBN determinations, for example, it is even absolutely necessary. For pH titrations the sensor used must have been previously calibrated.

---

### 7.3.5 Evaluation of pK and HNP values

---

From the data of the titration curve of an acid/base titration the acidic or basic strength of a sample can be determined. For this purpose the **pK** value or the **HNP** value can be determined automatically. The following formula applies:

$$\text{pH} = \text{pK} + \log(a_{\text{B}}/a_{\text{A}})$$

If  $a_{\text{B}} = a_{\text{A}}$ , then  $\text{pH} = \text{pK}$ .

The **pK** value determined is the volume at the half neutralization point, which can be obtained from the titration curve. Careful calibration of the pH electrode used is a precondition for a correct determination of the pK value. In non-aqueous solutions the half neutralization potential (**HNP**) is often used instead of the **pK** value. The **HNP** value is evaluated in the same way as the **pK** value.

---

**The various parameters for the MET modes are described in detail on pages 143 to 147.**

## 7.4 SET Titration to a preset endpoint

### Application:

**SET** modes are rapid titration modes for titrations to a preset endpoint. They correspond to manual titrations and are suitable for rapid determinations of non-critical samples.

Their typical feature is controlled reagent dosing depending on the control difference (actual value – endpoint) with the aim of reaching the preset value defined as the endpoint as quickly and accurately as possible. Overshooting is virtually eliminated. No automatic endpoint recognition is carried out.

**Important:** the endpoint should be selected so that it is near a point of inflection of the expected titration curve; it should not lie in an area where the slope is too steep.

Accurate results in the **SET\_PH\*** mode can only be expected when the sensor used has been previously calibrated correctly.

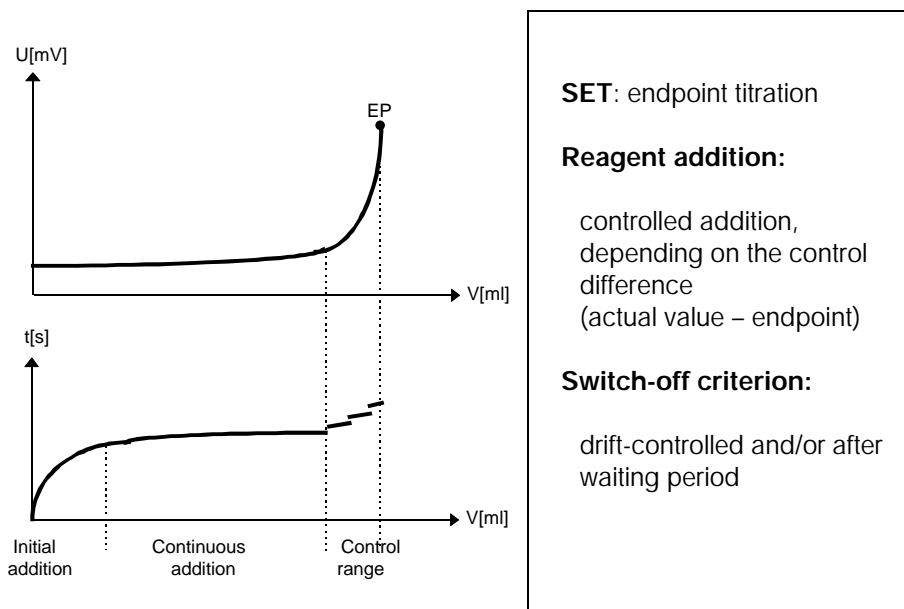

### 7.4.1 Measuring mode

An endpoint titration can be carried out with four different types of measurement:

- potentiometric pH measurement (**SET\_PH\***)
- potentiometric voltage measurement (**SET\_U\***)
- amperometric measurement with selectable polarization voltage (**SET\_UPOL\***)
- voltametric measurement with selectable polarization current (**SET\_IPOL\***)

### 7.4.2 Reagent addition

Reagent addition takes place in three different phases. The initial addition takes place with increasing dosing speed. It begins with the defined 'Min. Rate' and increases up to the 'Max. Rate'.

Dosing is carried out at the defined 'Max. Rate' until the control range is entered.

Within the control range the dosing speed depends on the control difference (actual value – preset endpoint) and becomes slower and slower as the endpoint is approached. In this (final) phase addition is carried out in single dosing steps at the minimum dosing rate.

Three predefined sets of parameters, which can be further optimized, are available in the 796 Titroprocessor for setting the titration control and the stop criterion.

### 7.4.3 Measuring point list

Entering the measured values and their corresponding data in the measuring point list is carried out at predefined measuring intervals and can be switched off. However, a measuring point list is required if a titration curve is to be shown.

### 7.4.4 Switch-off criteria at the endpoint

The recognition of the endpoint and therefore the end of the titration can take place in two ways.

Stop criterion '**Time**' means that the endpoint must remain exceeded during the preset switch-off time.

Stop criterion '**Drift**' means that after the endpoint has been reached the predefined volume drift must not be exceeded. The volume drift can be interpreted as being the volume of reagent which is theoretically required to be added per minute to maintain the endpoint.

As it must be assumed that the first time the endpoint is reached the selected endpoint criterion has not yet been met, the smallest possible volume increment ( $1/10\,000$  of the buret volume) is added at the minimum dosing rate until the endpoint criterion has been fulfilled.

Three predefined sets of parameters, which can be further optimized, are available in the 796 Titroprocessor for setting the titration control and the stop criterion.

**The various parameters for the SET modes are described in detail on pages 148 to 153.**

#### What to do if ...

Observation	Possible causes and remedies
Final addition lasts too long and increments are too small. "Will never end!"	<ul style="list-style-type: none"> <li>• Increase 'Min.Rate'. Carry out a test at a much higher Min.Rate.</li> <li>• Alter switch-off criterion, e.g. try increasing the stop drift or use a shorter switch-off time as the stop criterion.</li> <li>• Try leading an inert gas through the titration vessel.</li> </ul>

Observation	Possible causes and remedies
"Overshoots". Titration is not settled, i.e. single pulses are not added at the end.	<ul style="list-style-type: none"> <li>• Reduce 'Max. Rate'.</li> <li>• Set a larger control range.</li> <li>• Set a much smaller 'Min. Rate'.</li> <li>• Optimize the arrangement of the electrode and buret tip and improve the stirring. This is particularly important for very rapid titration reactions and for steep curves.</li> </ul>
Titration time is too long.	<ul style="list-style-type: none"> <li>• Set higher 'Min. Rate'.</li> <li>• Set higher 'Max. Rate'.</li> <li>• Reduce 'Control range'.</li> </ul>
Titration results scattered too much.	<ul style="list-style-type: none"> <li>• Set lower 'Min. Rate'.</li> </ul>

## 7.5 SEC Endpoint conditioning

### Application:

**SEC** modes are independent titration modes which can be used in the preparation of a **SET** mode. They are suitable for rapidly bringing a titration sample to a certain measuring value (endpoint).

Their typical feature is controlled reagent dosing depending on the control difference (actual value – endpoint) with the aim of reaching the preset value as quickly and accurately as possible. Overshooting is virtually eliminated. No provision is made for the representation of curves or carrying out calculations.

Reagent addition and switch-off criteria correspond to those of the **SET** modes.

### 7.5.1 Control of the conditioning mode

Conditioning is normally carried out in the background, i.e. as soon as a conditioning mode has been started the 796 Titroprocessor can carry out other commands (i. e. **ASK**, **ADD\_A** etc.). A conditioning process also remains active even when a determination has been finished, provided that it has not been explicitly terminated; see below.

A conditioning mode carried out in the background is controlled by the **WAIT\_C** command (see page 209f). This checks whether the conditioned state has been achieved and, if necessary, switches the conditioning mode off.

**Example:**

```

SEC_U* _____|
CTRL_RS1 ...      |
...                |
...                |
WAIT_C ... _____|
ASK                |
SET_U*             |

```

The **WAIT\_C** command synchronizes the background conditioning process with the method being carried out in the foreground. The **WAIT\_C** command interrupts the regular method run until the background process (conditioning) has been completed.

**Note!** Every titration, measuring or calibration mode also terminates background conditioning. Achievement of the conditioned state is not taken into account.

The various parameters for the SEC modes are described in detail on pages 154 to 157.

## 7.6 KFT Karl Fischer titrations

### Application:

The **KFT** modes are rapid titration modes for the volumetric determination of moisture according to the Karl Fischer method.

Their typical feature is controlled reagent dosing depending on the control difference (actual value – endpoint) with the aim of reaching the preset value as quickly and accurately as possible. Overshooting is virtually eliminated.

**Important:** It is absolutely necessary to take care that all work is carried out in the absence of water. The titration must be carried out in a tightly sealed titration cell so that atmospheric moisture cannot affect the titration. If this should not be possible, e.g. if a sample changer is being used, then a blank value should always be determined and subtracted from the actual reagent consumption when the results are being calculated.

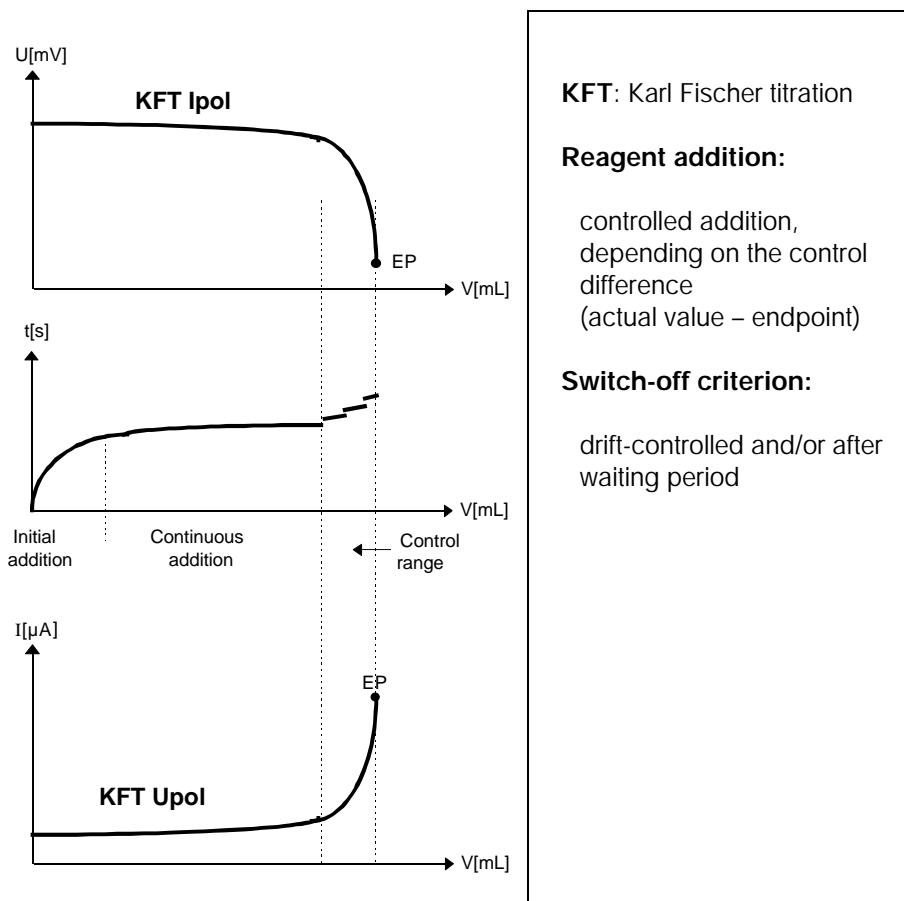

### 7.6.1 Measuring mode

A Karl Fischer titration can be carried out with two different types of measurement:

- voltametric measurement with selectable polarization voltage (**KFT\_IPOL\***)
- amperometric measurement with selectable polarization current (**KFT\_UPOL\***)

In **IPOL** measurements steep curves are obtained; in **UPOL** measurements the curves tend to be flatter.

For standard KF titrations the **IPOL** mode with the preset standard parameters is recommended. The **UPOL** mode should be selected for back titrations.

### 7.6.2 Reagent addition

---

Reagent addition takes place in three different phases. The initial addition takes place with increasing dosing speed. It begins with the defined 'Min. Rate' and increases up to the 'Max. Rate'.

Dosing is carried out at the defined 'Max. Rate' until the control range is entered.

Within the control range the dosing speed depends on the control difference (actual value – preset endpoint) and becomes slower and slower as the endpoint is approached. In this (final) phase addition is carried out in single dosing steps at the minimum dosing rate.

Three predefined sets of parameters, which can be further optimized, are available in the 796 Titroprocessor setting the titration control and the stop criterion.

### 7.6.3 Measuring point list

---

Entering the measured values and their corresponding data in the measuring point list is carried out at predefined measuring intervals and can be switched off. However, a measuring point list is required if a titration curve is to be shown.

### 7.6.4 Switch-off criteria at the endpoint

---

The recognition of the endpoint and therefore the end of the titration can take place in two ways.

Stop criterion '**Time**' means that the endpoint must remain exceeded during the preset switch-off time.

Stop criterion '**Drift**' means that after the endpoint has been reached the predefined volume drift must not be exceeded. The volume drift can be interpreted as being the volume of reagent which is theoretically required to be added per minute to maintain the endpoint.

As it must be assumed that the first time the endpoint is reached the selected endpoint criterion has not yet been met, the smallest possible volume increment ( $1/10\,000$  of the buret volume) is added at the minimum dosing rate until the endpoint criterion has been fulfilled.

Three predefined sets of parameters, which can be further optimized, are available in the 796 Titroprocessor setting the titration control and the stop criterion. The preset standard values provide correct and easily reproducible results in the vast majority of cases.

Titer determinations should always be carried out with the same parameters as were used for the sample titrations.

**The various parameters for the KFT modes are described in detail on pages 158 to 166.**

**What to do if ...**

Observation	Possible causes and remedies
Final addition lasts too long and increments are too small. "Will never end!"	<ul style="list-style-type: none"> <li>• Increase 'Min.increment'.</li> <li>• Alter switch-off criterion, e.g. try increasing the stop drift or use a shorter switch-off time as the stop criterion.</li> <li>• Change the solvent for problematic samples, e.g. for ketones or aldehydes the use of 2-methoxyethanol or a mixture of methanol/glacial acetic acid for amines can be recommended, see technical publications.</li> </ul>
The increments at the end of the titration are too large. "Overshoots".	<ul style="list-style-type: none"> <li>• Reduce 'Max. Rate'.                      An indication of the optimal Max. Rate is provided by the following experiment: observe the drift during conditioning and add the sample substance without starting the titration. Select a value below the highest drift as the 'Max. Rate'.</li> <li>• Optimize the arrangement of the electrode and buret tip and improve the stirring.</li> </ul>
At the end of the titration the solution is too brown.	<ul style="list-style-type: none"> <li>• The methanol content in the solvent solution is too low. Change the solvent.</li> <li>• The electrode may be coated; wipe off with acetone.</li> </ul>
Solution becomes darker after each titration.	<ul style="list-style-type: none"> <li>• Renew solvent.</li> <li>• The electrode may be coated; wipe off with acetone.</li> </ul>
The drift increases after every titration.	<ul style="list-style-type: none"> <li>• Does the sample only release water slowly? Use the KF oven.</li> <li>• Are acids esterified in the sample? Change the solution more frequently. Increase the buffering capacity of the solvent.</li> <li>• Does the sample contain ketones or aldehydes? Use special reagents which are suitable for ketones and aldehydes.</li> </ul>
The endpoint is reached "too quickly".	<ul style="list-style-type: none"> <li>• Reduce Max.rate.</li> </ul>
The titration times become longer and longer.	<ul style="list-style-type: none"> <li>• With 2-component reagents the buffering capacity of the solvent may be exhausted. Change the solution.</li> <li>• If the drift increases at the same time please see above.</li> </ul>

## 7.7 KFC Karl Fischer conditioning

### Application:

The KFC modes are independent titration modes which can be used in preparation of a **KFT** mode. They are suitable for rapidly bringing a titration sample to a certain measuring value (endpoint).

Their typical feature is controlled reagent dosing depending on the control difference (actual value – endpoint) with the aim of reaching the preset value as quickly and accurately as possible. Overshooting is virtually eliminated. No provision is made for the representation of curves or carrying out calculations.

Reagent addition and switch-off criteria correspond to those of the **KFT** modes.

### 7.7.1 Control of the conditioning mode

Conditioning is normally carried out in the background, i.e. as soon as a conditioning mode has been started the 796 Titroprocessor can carry out other commands. A conditioning process also remains active even when a determination has been finished, provided that it has not been explicitly terminated; see below.

A conditioning mode carried out in the background is controlled by the **WAIT\_C** command (see page 209f). This checks whether the conditioned state has been achieved and, if necessary, switches the conditioning mode off.

### Example:

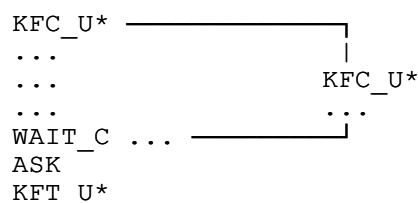

The **WAIT\_C** command synchronizes the background conditioning process with the method being carried out in the foreground. The **WAIT\_C** command interrupts the regular method run until the background process (conditioning) has been completed.

**Note!** Every titration, measuring or calibration mode also terminates background conditioning. Achievement of the conditioned state is not taken into account.

Conditioning should always be carried out with the same parameters as were used for the sample titration (**KFT** modes).

**The various parameters of the KFC modes are described in detail on pages 167 to 170.**

## 7.8 MEAS Extended measuring functions

### Application:

**MEAS** modes are universal measuring functions with which various measurable variables of a sample can be recorded. Their features are drift or time-controlled recording from one or more measuring points over a particular period of time.

### 7.8.1 Measuring modes

---

The following variables can be recorded:

- potentiometric pH measurement (**MEAS\_PH\***)
- potentiometric voltage measurement (**MEAS\_U\***)
- amperometric measurement with polarization voltage (**MEAS\_UPOL\***)
- voltametric measurement with polarization current (**MEAS\_IPOL\***)

In each of these measuring modes the sample solution temperature can be determined in parallel for each measuring point and for pH measurements the value recorded can be appropriately corrected.

- drift or time-controlled temperature measurement (**MEAS\_T\***)

### 7.8.2 Standard measurement

---

The standard measurement represents a simple individual measurement which may be drift-controlled or time-controlled. For example, in order to record the reaction behavior of a sensor it is possible to record the raw data of the measurement at short time intervals (sampling time) and to assess them as a measuring curve.

**Note:** these raw data are not exact measuring data; they are unfiltered and influenced by the background noise of the measuring system.

The 'smoothed', i.e. filtered final measurement value (variable **CM**) should be used for calculations.

#### Drift / time-controlled measurement acceptance

Measurement acceptance is carried out to the same principles as in a monotonic (**MET**) titration. In drift-controlled measurement acceptance the measurement drift of the sensor must be less than a defined amount in order to be accepted as a valid measurement. If after a defined waiting period has elapsed this measurement drift has not been undercut then the momentary measurement will be accepted. For time-controlled measurement acceptance the measurement drift must be switched off. In this case only the set waiting period is decisive for the measurement.

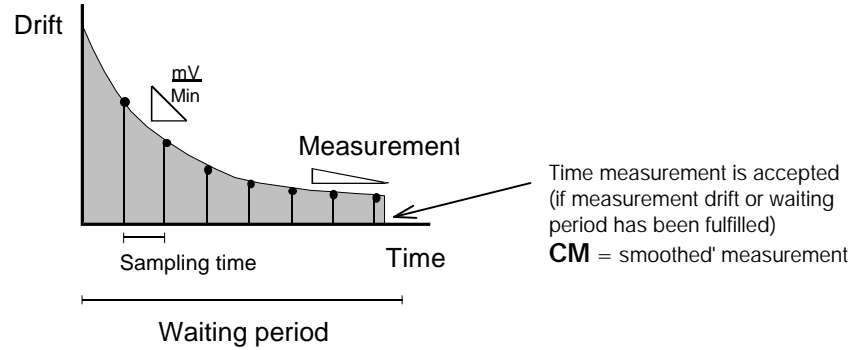

### 7.8.3 Multiple measurement

A multiple measurement consists of a series of drift or time-controlled individual measurements. For the measurement acceptance of the individual measurements the same parameters as for the above-mentioned standard measurements are decisive. Each entry in the measuring point list is a 'smoothed' value.

The data recording parameters determine the measuring series run. The number of measurement cycles and the measuring interval determine the time taken for the series of measurements. The measuring interval defines the time pattern at which the individual measurements are triggered. Depending on the type of measurement acceptance and the stability of the measuring signal the time at which the measurement is entered into the measuring point list may differ from the time pattern. It is very important that the waiting period for the measurement acceptance is selected to be shorter than the measuring interval, i.e. the waiting period for the individual measurements should have safely elapsed when the next measurement (according to the measuring interval) is started.

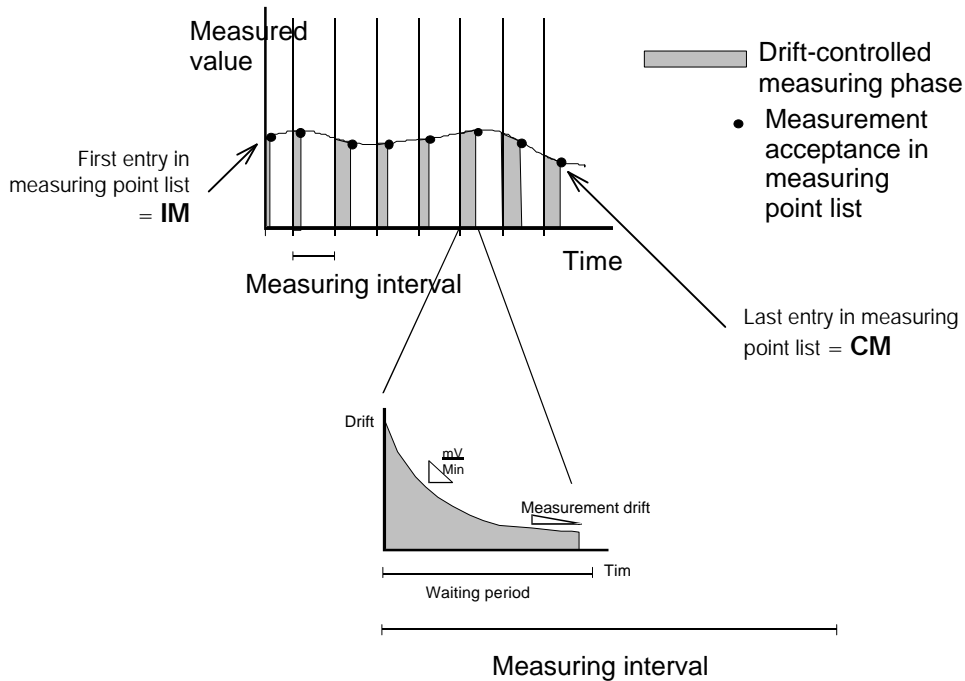

The various parameters of the MEAS modes are described in detail on pages 171 to 177.

## 7.9 CAL Calibration of pH sensors

### Application:

The calibration of a pH sensor is indispensable not only for pH measurements; it is also essential for **SET** titrations and for the correct determination of pK values and fixed endpoints.

In contrast to manual sensor calibration, the **CAL** mode allows the calibration parameters and individual buffer series to be set down in a method. The calibration data, like all determination data, can be stored and are available for subsequent data output; however, they cannot be reactivated.

### Calibration principle

During the pH calibration an isotherm (constant temperature) of the pH value is recorded as a function of the electrode system voltage (electrode system = sensor + electrode cable + connection socket + measurement interface) and used for the conversion of the measured voltages into pH values. This means that all the buffer solutions used for the calibration must be at the same temperature, even with automatic temperature correction using a temperature sensor. If possible the calibration should be carried out at the same temperature as that at which the later measurements will be carried out.

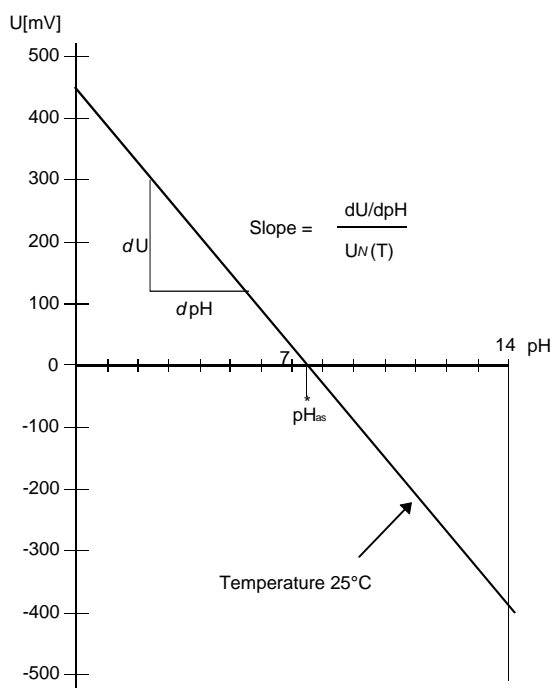

- **Without calibration** the relative slope of the electrode system will be 1 and  $pH_{7,as}$  will be set at 7.

Depending on the requirements for accuracy the calibration can be carried out with 1, 2 or up to 9 buffer solutions.

- **1-point calibration:** the relative slope is set at 1 and the position of the calibration curve (isotherm) determined by the buffer solution used, which is equivalent to compensating the asymmetry pH value  $\text{pH}_{\text{as}}$  of the measuring system.
- **2-point calibration:** by using two calibration values not only the coordinate  $\text{pH}_{\text{as}}$ , but also the relative slope of the calibration curve (isotherm) is fixed. This is the commonest type of calibration.
- **n-point calibration:** for more than 2 calibration points (max. 9) the compensation curve (linear regression according to the method of the smallest mean-square error) is determined, i.e. the  $\text{pH}_{\text{as}}$  and slope of the best fitting calibration curve (isotherm) through all calibration points are determined. If  $n > 2$  the same buffer value can be used several times and thus more heavily weighted. However, two measurements cannot be carried out on the same buffer in sequence.

### Drift / Time-controlled measurement acceptance for the calibration

Measurement acceptance during a calibration is carried out according to the same principles as in a monotonic (**MET**) titration or a **MEAS** mode. In drift-controlled measurement acceptance the measurement drift of the sensor must be less than a defined amount in order to be accepted as a valid measurement. If after a defined waiting period has elapsed this measurement drift has not been undercut then the momentary measurement will be accepted. For time-controlled measurement acceptance the measurement drift must be switched off. In this case only the set waiting period is decisive for the measurement.

### Verification of the calibration

For the recognition of a measured calibration value its agreement with the theoretical value is checked. This is done by using the internally stored buffer tables of the various manufacturers and buffer types. The measured potential is compared with the theoretical value of the specific buffer taking the calibration temperature into account.

For a valid calibration value the measured potential may differ from the theoretical value by **not more than 30 mV**.

The temperatures of the buffer solutions must all lie within a range of **2°C**.

**The various parameters of the CAL mode are described in detail on pages 178 to 182.**

## 7.10 Calculations / Formulas

10 calculation formulas can be defined for each titration or measuring mode. This is done by selecting the appropriate mode in the method editor with the cursor and pressing the softkey [**\* Formula**].

**\* Formel**

#	Comment	Formula (R\$\$, C##, X\$\$, EP# ...)	Unit	Dec	Type
1	<b>Gehalt</b>	R01=EP1*C*C01*145.65*100/SS	%	2	normal
2					
3					
4					
5					
6					
7					
8					
9					
10					

QUIT

Copy line	Cut line	Paste line				Insert line	Delete line	
-----------	----------	------------	--	--	--	-------------	-------------	--

- Formulas which have been entered in the method editor are available for the following determinations. If existing data are to be recalculated then the formula editor must be called up in the result window. Modified or newly added formulas can be recalculated there.

---

**Alterations which have been made in the formula editor of the result window for recalculations are not automatically incorporated into the method.**

---

- The variable names for results (**Rxx**) and intermediate results (**Xxx**) should be selected to be unambiguous. The same variable names can be used several times. The contents of the variable is then overwritten each time. This must be taken into account when such a variable is to be used in a calculation. Only the current contents of the variable is available. Only one version of the variable can be used for statistical purposes.
- If several modes with their own sets of formulas are programmed in one method then it is possible to access the calculated results and intermediate results of the previous modes. However, this does not apply to system variables (**EPx**, **CM**, etc. ) which are created directly by the previous titration or measurement. If required, these can be stored as intermediate results (**Xxx**).
- If common variables are used in a formula then these are always the common variables which were in force at the start of the determination. In each determination copies of the common variables are laid down locally and accessed as required. When determination data are stored these are saved in the same record and are available for recalculations.
- If the values of the common variables are altered in a determination (**Cxx=...**) then these new values are available for the first time for the next determination (global common variable).

<b>Remark</b>	<b>Formula name</b>
	<i>11 characters</i>
Each formula can be given any name. The name only has a descriptive character.	
<b>Formula</b>	<b>Calculation formula</b>
	<i>35 characters</i>
A formula consists of a variable (final result, intermediate result or common variable), which is allocated to the result of the calculation and the calculation formula itself, which can consist of mathematical operators, numerical values, common variables and system variables. Results of previous calculations also belong to the system variables.	
Calculation results can be allocated the following variables:	
<b>R00...RZZ</b>	Final result, is given on the result page and in reports; can be used for calculations, statistics and live displays.
<b>X00...XZZ</b>	Intermediate result, is not shown; can be used for calculations, statistics and live displays.
<b>C01...C19</b>	Common variables, are given on the result page and in reports; can be used for calculations, statistics and live displays. They are globally available for subsequent determinations.
<b>Unit</b>	<b>Unit of the result</b>
	<i>%   ppm   g/L   mg/mL   mg/pc    mol/L   g   mg   mL   s   mL/min    max. 6 characters</i>
Any other unit can be entered apart from the selection of units given above,.	
<b>Dec</b>	<b>Decimal place in the result</b>
	<i>0...5</i>
The result of the calculation will be rounded off to the number of decimal places given above and this rounded-off value enters the statistics. If the result is used internally for other calculations then the original and completely accurate value will be used.	
<b>Type</b>	<b>Type of result</b>
	<i>normal   stat.   live</i>
The type of result determines how it will be shown:	
<b>normal</b>	The result is shown in the result window and in the report.

<b>stat.</b>	The result enters the statistics.
<b>live</b>	The result is shown in the trace window during the determination and recalculated each time a new entry is made in the measuring point list. Please note that in titrations the live value may not be quite as up-to-date as the actual value.

### Softkeys

<b>[Copy line]</b>	copies the contents of the selected line into a local buffer memory.
<b>[Cut line]</b>	copies the contents of the selected line into a local buffer memory and deletes the selected line.
<b>[Paste line]</b>	inserts a new line before the selected line and enters the contents of the local buffer memory in it.
<b>[Insert line]</b>	inserts a new empty line before the selected line.
<b>[Delete line]</b>	deletes the selected line.

### 7.10.1 System variables

The following system variables can be used in formulas.  
 (xx=any 2 numbers or letters, #=any number)

<b>Rxx</b>	Result
<b>RT1</b>	Result for validation
<b>RT2</b>	Theoretical result for validation
<b>RE</b>	Result for calculating the system error in validation
<b>Xxx</b>	Intermediate result
<b>C##</b>	Common variable (of the actual titration or measurement)
<b>EP#</b>	Endpoint volume in mL
<b>EM#</b>	Endpoint measurement (unit depends on mode)
<b>EF#</b>	Endpoint flag; endpoint found yes/no (1/0)
<b>F#</b>	Fixed endpoint volume in mL
<b>FM#</b>	Fixed endpoint measurement (unit depends on mode)
<b>FF#</b>	Fixed endpoint flag; fixed endpoint reached yes/no (1/0)
<b>MNRxx</b>	Mean value of results Rxx in statistics memory
<b>MNXxx</b>	Mean value of intermediate results Xxx in statistics memory
<b>MNC##</b>	Mean value of common variables C##
<b>ID1</b>	Sample identification 1
<b>ID2</b>	Sample identification 2
<b>ID3</b>	Sample identification 3
<b>SS</b>	Sample size (value without units)
<b>DD</b>	Determination duration in s, time for whole determination
<b>MD</b>	Measuring duration in s; time for actual titration or measurement
<b>SD</b>	Starting duration in s; length of start phase of a mode
<b>IT</b>	Initial temperature in °C
<b>ST</b>	Starting temperature in °C (after start phase), only for automatic measurements.
<b>CT</b>	Closing temperature in °C, only for automatic measurements

<b>IM</b>	Initial measured value (unit depends on mode)
<b>SM</b>	Measured value after the start phase of a titration or measurement
<b>CM</b>	Measured value at end of a titration or measurement
<b>SV</b>	Added starting volume in mL
<b>CV</b>	Added volume at end of a titration in mL
<b>C</b>	Concentration of reagent (value without units)
<b>HNV#</b>	HNP volume in mL (half neutralization potential)
<b>HNP#</b>	HNP value (unit depends on mode)
<b>AP</b>	Asymmetry pH ( $\text{pH}_{\text{as}}$ ) of the calibrated sensor used
<b>SL</b>	Slope of the calibrated sensor used
<b>DRC</b>	Volume drift in conditioned status (in $\mu\text{L}/\text{min}$ )
<b>DOD</b>	Dosing duration in s, length of the dosing increments added together (for SET and KFT modes)
<b>ITD</b>	Duration between end of conditioning and start of the following titration in s
<b>\$RN</b>	Sample number, run number
<b>\$AS</b>	Autostart counter
<b>\$CRF</b>	Conditioning flag (conditioning OK, yes/no (1/0))
<b>COV</b>	Conditioning volume in mL
<b>\$BC</b>	Buffer counter
<b>\$LV</b>	Live volume in mL, added volume to live value display
<b>\$LM</b>	Live value, actual value to live value display
<b>\$LD</b>	Live measurement duration in s, actual duration to live value display

### 7.10.2 Mathematical functions

<b>+</b>	Addition
<b>-</b>	Subtraction
<b>*</b>	Multiplication
<b>/</b>	Division
<b>^</b>	Exponentiation
<b>( )</b>	Expression in brackets
<b>LOG()</b>	Decimal logarithm
<b>EXP()</b>	Decimal exponent
<b>LN()</b>	Natural logarithm
<b>SQRT()</b>	Square root
<b>TST( , )</b>	Test function (tested variable, substitution term)
<b>ABS()</b>	Absolute value (unsigned)

All the above mathematical functions can be used in formulas. Expressions in brackets can be combined at will. The recognized rules of priority for mathematical functions apply. The formula editor has an automatic syntax checking function.

If errors such as missing or invalid variable contents occur while the calculation formulas are being carried out (at the conclusion of the titration or measuring mode) then a warning is given and the error message is entered in the error list on the result page. The error list is included in the result report.

### The test function TST( , )

If invalid values should occur during a calculation (e.g. missing endpoints) the **TST()** function can still be used to obtain a correct calculation. The syntax:

**TST(variable to be tested, substitution term)**

If the value of the variable specified is invalid in the calculation then this will be carried out with the substitution term (variable or formula).

#### Examples:

- In order to check the existence of an endpoint the **TST()** function can be used in the following form:

$R01 = \text{TST}(EP1, 0) * C01 * C * 157.45 * 100 / SS$

If no endpoint is present then the result R01 is not invalid. The correct result zero (0) will be shown.

- If several equivalence points are expected in a titration it is recommended that these are assigned to an EP window and that the calculation formulas are so defined that if an EP is missing all the calculations are nevertheless carried out correctly. The following is an example of a halide determination.

#	Comment	Formula (R\$\$, C##, X\$\$, EP# ...)	Unit	Dec	Type
1	Vol.iodide	$RV1 = \text{TST}(EP1, 0)$	mL	3	normal
2	Vol.bromide	$RV2 = \text{TST}(EP2, RV1) - RV1$	mL	3	normal
3	Vol.chloride	$RV3 = \text{TST}(EP3, RV2 + RV1) - RV2 - RV1$	mL	3	normal
4	Iodide	$RJ = RV1 * C * 126.9 * 1000 / SS$	mg/L	2	stat.
5	Bromide	$RBR = RV2 * C * 79.9 * 1000 / SS$	mg/L	2	stat.
6	Chloride	$RCL = RV3 * C * 35.45 * 1000 / SS$	mg/L	2	stat.

### Setting flags

Flags have the status true or false and are used to indicate a particular condition or event. The status 'true' corresponds to the value 1 and the status 'false' to the value 0. In this way flags can be used for calculations.

## 7.11 Reports

Separate reports can be defined for each mode and handled as part of the full report of the determination. They are produced immediately after the individual mode has been concluded. They cannot just be printed out, but can also be transferred directly to a LIMS system, e. g. the Metrohm **VESUV** software.

The definition of the report of a titration or measuring mode is carried out in the report editor window of the method; this can be opened with the softkey [ \* Report ] when the appropriate report has been selected with the cursor.

* Report					
	Type	Specification	print	send	FF
Reports for titration/ measuring modes	V_Curve	M. value	yes	no	no
	*Stand		yes	no	no
			no	no	no
			no	no	no
			no	no	no
<hr/>					
	Type	Specification	Print	Send	FF
Reports to be printed on full statistics counter	*ShrtRes		yes	no	no
			no	no	no
			no	no	no
			no	no	no
QUIT					

The reports are printed out in the defined sequence. In the lower half of the editing window those reports are defined which are only to be printed out when the number of determinations which were defined for the statistical evaluation of a series of samples has been carried out.

Type	Type of report
depending on mode:	<i>C_Curve</i>   <i>V_Curve</i>   <i>T_Curve</i> <i>MCurve_V</i>   <i>MCurve_T</i> <i>*Stand</i>   <i>*FullRes</i>   <i>*ShrtRes</i> <i>SamplData</i>   <i>CalData</i>   <i>*Param</i>   <i>MP_List</i> <i>Calcn.</i>   <i>RawData</i>   <i>FormFeed</i>   <i>FullStat</i>   <i>ShrtStat</i>

Depending on the titration or measuring mode different reports can be selected. In curve reports the specifications of the axis, i.e. the measured quantity on the Y-axis can be additionally defined.

<i>C_Curve</i>	Calibration curve (only in *CAL mode)
<i>V_Curve</i>	Volume curve (curve on the volume axis)
<i>T_Curve</i>	Time curve (curve on the time axis)
<i>MCurve_V</i>	Multi-curve on the volume axis +
<i>MCurve_T</i>	Multi-curve on the time axis +
<i>*Stand</i>	Standard report
<i>*FullRes</i>	Full result report, detailed
<i>*ShrtRes</i>	Short result report, minimal
<i>SamplData</i>	Sample data with size
<i>CalData</i>	Calibration data report
<i>*Param</i>	Parameter report for mode

<i>MP_List</i>	Measuring point list
<i>Calc.</i>	Calculation report with formulas
<i>RawData</i>	Raw data report for LIMS output
<i>FormFeed</i>	Page feed at printer
<i>FullStat</i>	Full statistics data report
<i>ShrtStat</i>	Short statistics data report

\* Multiple curves of all determinations in the statistics memory

For routine titrations a standard report with a volume curve is recommended as this contains the most important data for the determination; see example on page 127.

Specification	Measuring quantity on the Y-axis of a curve
Depending on curve type:	<b>Measured value</b>   <i>Volume</i> <i>Temp.</i>   <i>dMV/dV</i>   <i>dMV/dt</i>   <i>dV/dt</i> <i>MV,Temp.</i>   <i>MV,dMV/dV</i>   <i>all</i>

If a curve report has been selected then a specification for representation of the measuring quantity on the X-axis can be entered. Different entries can be selected depending on the type of curve.

<i>M.value</i>	Measured value: pH, mV, $\mu$ A, °C depending on mode
<i>Volume</i>	Added volume in mL
<i>Temp.</i>	Temperature in °C
<i>dMV/dV</i>	1st derivative of titration curve according to volume
<i>dMV/dt</i>	1st derivative of titration curve according to time
<i>dV/dt</i>	1st derivative of volume according to time
<i>MV,Temp</i>	Measured value and temperature, combined
<i>MV,dMV/dV</i>	Measured value and 1st derivative combined
<i>all</i>	all representable quantities

The scaling of the Y-axis of a curve report in the definition of the curve display under [**\* Param**] [**Curve display**]- **Division**. The use of a grid for the output of a curve can also be switched on here.

For page-oriented printers the definition of a page feed before each curve report is recommended, see **FF** below.

print	Print out the report
	<b>yes</b>   <i>no</i>

A report will be printed out (with '**yes**') on all the printers defined in the configuration. These can be both the internal printer as well as an external printer connected to the 'Printer' socket or an RS 232 interface.

---

**send****Report output via an RS 232 interface**yes | **no**

A report can be transferred directly to a personal computer via an RS 232 interface. In the configuration of the interfaces this particular interface must have been defined as the communications interface; it must be connected to the receiving instrument and the data transmission mode '**LIMS**' must be switched on. Take care that the transmission parameters (baud rate, etc.) have been set to the same values on the receiving instrument as for the 796 Titroprocessor.

For storing determination data in a database the Metrohm database **VESUV 3** is recommended; this can evaluate the raw data reports of the 796 Titroprocessor. Details can be found in the **VESUV 3** instruction manual.

---

**FF****Page feed (form feed) at the printer**yes | **no**

For formatting the printout of several report blocks a page feed can be defined after each individual report. A 'Form Feed' only affects the printer. Please note that the internal thermal printer will only carry out a form feed when '**Enable auto FF**' is switched on in the interface configuration.

**Note:** if reports are to be printed out on a page-oriented external printer (inkjet printer, laser printer) then in order to print out the final page of the report a page feed must be carried out after the last report. This is done by switching on '**Final form feed**' in the determination report, see page 77.

Example of a volume curve:

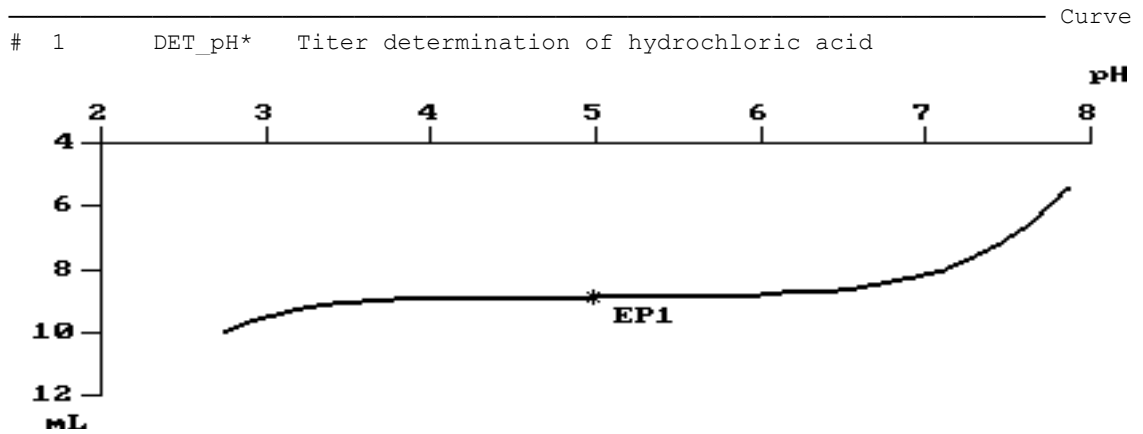

Example of a standard report:

\*Standard report

Method	Ident1	Ident2	Ident3	Weight	Unit
HCl	970312-2			0.10804	g
Remark					

---

#	1	DET_PH*	Titer determination of hydrochloric acid
EP1	pH	4.989	8.907 mL Titer 1.0013
Stop condition			Measured value

# 8 Command Reference

A method comprising various commands can be programmed in the method editor. A method may comprise a maximum of 99 command lines. Methods can be saved and reloaded direct from the method editor (softkey **[File]** ).

<b>Titration</b>	<b>&gt;</b>
Changer	>
CAL	>
MEAS_*	>
DOS	>
STIR_I	>
CASE	>
COMM	>
AUX	>

The various commands of the 796 Titroprocessor can basically be divided into two different groups.

On the one hand, there are the titration and measuring modes (incl. calibrating and conditioning modes), which comprise a considerable number of parameters and settings, and primarily generate determination data. The extended settings are accessible for the mode marked with the cursor using the softkeys designated by an asterisk (**[\* Param]**, **[\* Formula]** and **[\* Report]** ). The parameters set in the corresponding sub-windows are only valid for this specific mode. Please note that due to the limited memory, no more than five such modes can be programmed in a method.

On the other hand, there are the simple function commands, containing only those parameters that can be entered directly in the method editor window.

## 8.1 Titration modes

Method: NEU.mth

t/s	Command	Parameter	Parameter
1	DET_PH*	Reagent Concentr. Dos. drive	Sensor Meas. input A1
2	MET_PH*	Reagent Concentr. Dos. drive	Sensor Meas. input A1
3	SET_PH*	Reagent Concentr. Dos. drive	Sensor Meas. input A1
4	SEC_PH*	Reagent Concentr. Dos. drive	Sensor Meas. input A1
5	KFT_IPOL*	Reagent Concentr. Dos. drive	Sensor Meas. input Apol
6	KFC_IPOL*	Reagent Concentr. Dos. drive	Sensor Meas. input Apol

QUIT

Note	File	Determ. report	* Param	* Formula	* Report	Insert line	Delete line	>>>
------	------	----------------	---------	-----------	----------	-------------	-------------	-----

## 8.2 DET

There is a choice of four different **DET** modes for controlled titrations with dynamic volume steps. They differ only in respect of the measurable variable:

<b>DET_PH*</b>	Measuring quantity pH
<b>DET_U*</b>	Measuring quantity mV
<b>DET_UPOL*</b>	Measuring quantity $\mu\text{A}$ (adjustable pol. voltage in mV)
<b>DET_IPOL*</b>	Measuring quantity mV (adjustable pol. current in $\mu\text{A}$ )

The following information applies to all **DET** modes. Discrepancies are indicated.

---

**DET\_PH\***

**dynamic equivalence point titration**

<b>Reagent</b>		<b>Sensor</b>	
<b>Concentr.</b>		<b>Meas. input</b>	<b>A1</b>
<b>Dos. drive</b>			<b>A1</b>

applies to  $\Rightarrow$

**DET\_PH\***, **DET\_U\***, **DET\_UPOL\***, **DET\_IPOL\***

**DET** modes create the following system variables:

<b>R\$\$</b>	end result / live result
<b>X\$\$</b>	intermediate resultat / live result (not to be printed out)
<b>C\$\$</b>	common variable (automatic assignment)
<b>EP#</b>	reagent volume at equivalence point #
<b>F#</b>	reagent volume at fixed endpoint #
<b>EM#</b>	measured value of equivalence point #
<b>FM#</b>	measured value of fixed endpoint #
<b>EF#</b>	flag (1/0) for equivalence point found #
<b>FF#</b>	flag (1/0) for fixed endpoint found #
<b>HNP#</b>	half neutralization potential HNP / pK value
<b>HNV#</b>	reagent volume at HNP in mL
<b>SV</b>	start volume in mL; consumption of initial dosing
<b>CV</b>	end volume in mL; total reagent volume added
<b>C</b>	concentration of reagent (as defined in method)
<b>IM</b>	initial measured value at start of mode; depends on meas. quantity
<b>SM</b>	initial value at start of measuring, after initial dosing
<b>CM</b>	end value of measuring or titration, depends on meas. quantity
<b>IT</b>	initial temperature at start of mode in $^{\circ}\text{C}$
<b>ST</b>	start temperature at start of measuring, after initial dosing
<b>CT</b>	end temperature at titration end in $^{\circ}\text{C}$
<b>MD</b>	duration of titration or measuring mode in s
<b>SD</b>	start duration in s (for initial procedures)
<b>\$LV</b>	live volume in mL; current reagent volume added
<b>\$LM</b>	live measuring value; current value (depends on meas. quantity)

---

**Assignment parameters of the DET modes:**

---

<b>comment</b>	<b>Comment on titration mode</b> <i>(52 characters)</i>
----------------	--

The comment on the mode serves to identify the specific titration in a determination. This is particularly useful for more complex methods with several titration or measuring modes.

---

<b>Reagent</b>	<b>Name of the reagent</b> <i>(13 characters, selectable)</i>
----------------	--

If a name is entered here, the automatic reagent control can be used. The field will have a list of items for selection if a reagent name has already been assigned under '**Devices & Manual Control**'.  
When the method is started, the entry under '**Devices & Manual Control**' (<MAN CONTROL> key) for the current occupancy of the addressed dosing drive is checked. If non-consistency is found an error message will be indicated.

Leaving the '**Reagent**' field empty (or on the '**Devices & ...**' page ) prevents an automatic reagent control.

---

<b>Sensor</b>	<b>Name of the sensor to be used</b> <i>(13 characters)</i>
---------------	--

If a name is entered here, the automatic sensor control can be used.

When the method is started, the entry under '**Devices & Manual Control**' (<MAN CONTROL> key) for the connected sensor is checked. If non-consistency is found an error message will be indicated.

Leaving the '**Sensor**' field empty (or on the '**Devices & ...**' page ) prevents an automatic sensor control.

---

<b>Concentr.</b>	<b>Concentration of the reagent</b> <i>(numerical   5 characters)</i>
------------------	--

Two fields for entering the concentration of the reagent solution and the unit of concentration. These fields are also (see above) used for the reagent control and, when the method is started, are carefully compared with the entry in the '**Devices & Manual Control**' dialogue window. The reagent concentration can be used for calculations. It is filed in the **C** system variable.

**Meas. input** **Sensor input**  
(A1,A2, Apol, Adiff, B1, B2, Bpol, Bdiff)

The measuring inputs **A1**, **A2** and **Apol** are located on the back of the Titroprocessor, integrated in the **sensors A** measuring interface. **Adiff** stands for the differential amplifier circuit on measuring inputs **A1**, **A2** and **Ref**.  
If there is a second measuring interface (**sensors B**), addresses **B1**, **B2**, **Bpol** and **Bdiff** can also be used analogously. Only feasible sensor addresses can be selected in line with the measuring quantity of the DET mode :  
e. g. with **DET\_IPOL\*** only **Apol** or **Bpol**.

**Dos. drive** **Dosing drive address**  
(A1...A4, B1...B4, C1...C4)

The ports **Dos. A1...Dos. A4** on the back of the unit are addressed **A1...A4**.  
Other drives connected to the 'External Bus' with a Dosimat Interface 729, are addressed **B1...B4** (Dosimat Interface 1, EBus address 1) resp. **C1...C4** (Dosimat Interface 2, EBus address 2).

**8.2.1 [ \* Param ] Specific parameters for DET modes**

The specific parameters of the corresponding **DET** mode will be found under the softkey [ \* Param ].

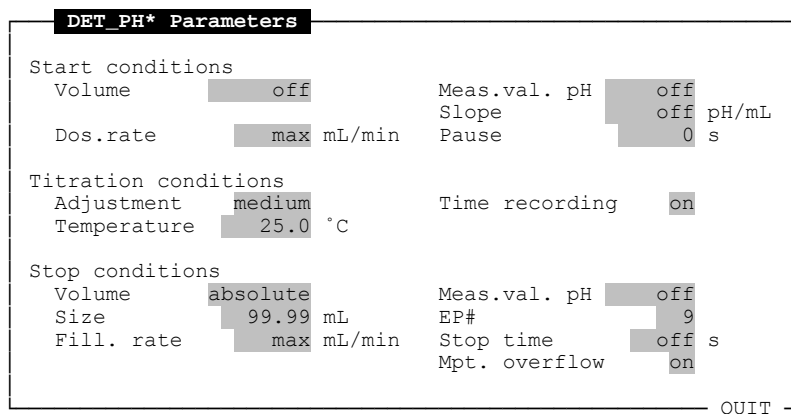

**Start conditions**

This is where the conditions which have to be fulfilled before titration can begin are defined. Titration reagents can be pre-dosed in a manner of different ways.

The addition of a defined start volume (absolute or relative volume as a function of the sample size) can be monitored optionally. If values are entered for **Meas.val.** and/or **Slope**, the addition of the defined start volume will be discontinued as soon as these threshold values are reached. Initial dosing without a defined start volume can be discontinued by monitoring the measured value or signal slope (pH/mL resp. mV/mL).

The various conditions governing the discontinuation of initial dosing can be combined at will.

**N.B.:** Initial dosing is discontinued on attainment of any of the start conditions, be it the defined absolute/relative start volume, the defined measured value or the signal slope. The actual titration will then start immediately after the pre-set pause.

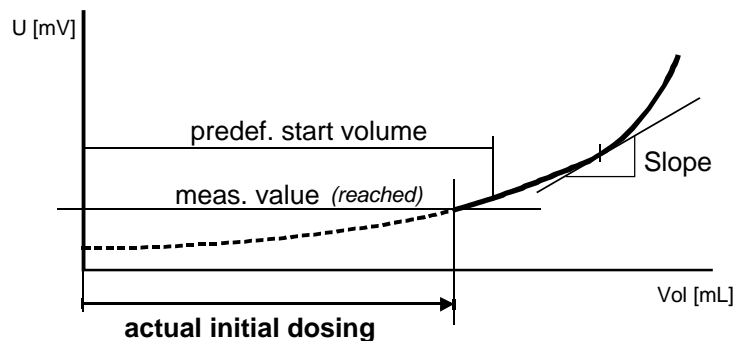

The volume actually dosed is filed in the **SV** system variable and can be called up for calculations.

---

<b>Volume</b>	<b>Definition of the start volume</b> <i>absolute   relative   off</i>
---------------	---

The defined start volume can be entered as an absolute volume, or as a relative volume as a function of the sample size (recommended). Various other fields\* will need to be edited depending on what is entered in this field (see below).

---

<b>Size</b> *	<b>Absolute volume</b> (with abs. start volume) <i>0...999.99 mL</i>
---------------	---

If an absolute start volume is entered, the start volume should be kept small enough to ensure that sufficient volume remains up to the equivalence point for the dynamically controlled titration.

---

<b>Factor</b> *	<b>Calculation factor</b> (with rel. start volume) <i>-99999...0...99999</i>
-----------------	---

The actual volume of the start volume to be added will be calculated as follows:

$$\text{Volume in mL} = \text{sample size} * \text{factor}.$$

The maximum start volume that can be added is 1000 mL. If the calculation results in a higher value, the start volume is automatically reduced to 1000 mL.

---

**Dos. rate** **Dosing rate of initial dosing**  
*0.01 mL/min...150 mL/min | max.*

The maximum dosing rate will depend on the size of the buret cylinder used.

<i>Buret cylinder</i>	<i>max. rate</i>
1 mL	3 mL/min
2 mL	6 mL/min
5 mL	15 mL/min
10 mL	30 mL/min
20 mL	60 mL/min
50 mL	150 mL/min

A value up to 150 mL/min can be entered even for small buret cylinders. When the method is executed, however, the dosing rate will be automatically reduced to the largest possible value. Select '**max**' whenever possible, except with viscous reagent solutions.

---

**Meas. val.** **Measured value for discontinuing initial dosing**

with DET_PH:	<i>pH -20 ... 20   off</i>
with DET_U, DET_IPOL:	<i>-2000 ... 2000 mV   off</i>
with DET_UPOL:	<i>-200 ... 200 µA   off</i>

The threshold value of the measured signal, on attainment of which initial dosing is discontinued. The controlled titration and data recording will then start after the pre-defined pause (if programmed).

The direction and the progress of the change in measured value have no incidence on the detection of this threshold value. The measured value must be exceeded anyway.

---

**Slope** **Signal slope for discontinuing initial dosing**

with DET_PH:	<i>0.1 ... 9.99 pH/mL   off</i>
with DET_U, DET_IPOL:	<i>0.5 ... 999 mV/mL   off</i>
with DET_UPOL:	<i>0.1 ... 99.9 µA/mL   off</i>

The maximum value of the change in measured signal per millilitre, on attainment of which initial dosing is discontinued.

The controlled titration and data recording will then start after the pre-defined pause (if programmed).

---

**Pause** **Pause before start of controlled titration**  
*0 ... 9999 s*

A pause can be inserted before controlled titration starts. If initial dosing is programmed, the pause will start on completion of this initial dosing.

---

**Titration conditions**

These are the actual titration parameters that control the dosing procedure and recording of measured values during the titration.

---

**Adjustment**
**Pre-defined sets of parameters**

*slow* | ***medium*** | *fast*

To facilitate setting the titration parameters, there is a choice of three different sets of parameters. These sets comprise a number of tried-and-tested settings which will suffice for the vast majority of requirements.

<i>slow</i>	for ultra-precise titrations or for chemically inhibited reactions requiring a long time
<i>medium</i>	standard parameter for non-problematical titrations, optimized for the most common applications
<i>fast</i>	fastest pre-set parameter for non-critical titrations

If the titration parameters need to be modified to specific titration problems, the various pre-set parameters can be adjusted on an individual basis.

The softkey [**Custom adjust**] opens another dialogue window in which user-defined settings can be entered (see p. 137f).

---

**Temperature**
**Setting the temperature or its measuring mode**

*-170...25.0...500°C* | *auto* | *initial*

The temperature during a titration can be determined automatically using a Pt100/Pt1000 sensor or a combined electrode with integral temperature sensor and can (with measuring quantity pH) be used to correct the pH automatically. The temperature during a titration can be recorded and printed out as a temperature curve.

<i>numerical</i>	Manual input (e. g. to correct the pH)
<i>auto</i>	Automatic measurement throughout the entire titration (for temperature curve)
<i>initial</i>	Single measurement at the beginning of the titration mode

The temperature can be integrated in formulas for calculations (see p. 129), e. g. for volume corrections. The following system variables are generated:

<b>IT</b>	Initial temperature at start of mode
<b>ST</b>	Start temperature before first dosing ( <i>auto</i> only)
<b>CT</b>	End temperature at last dosing ( <i>auto</i> only)

---

<b>Time recording</b>	<b>Recording measuring time</b> <i>on   off</i>
-----------------------	--

---

To record the titration curve on the axis of time (measured value against time) the time recording function has to be switched on. It can be switched off for recording the titration curve on the axis of volume. This keeps the determining files smaller, as less measured values are recorded and filed.

---

<b>U(pol)</b>	<b>Polarization voltage (DET_UPOL* only)</b> <i>-1270...400...1270 mV</i>
---------------	--

---

The polarization voltage is the voltage which is applied to a polarized electrode during the amperometric titration. The measuring quantity  $\mu\text{A}$  is obtained.

---

<b>I(pol)</b>	<b>Polarization current (DET_IPOL* only)</b> <i>-127...1...127 <math>\mu\text{A}</math></i>
---------------	--

---

The polarization current is the current that is applied to a polarized electrode during the voltametric titration. The measuring quantity mV is obtained.

---

**Stop conditions**

The stop conditions define when and how a titration should be terminated. In the same way as for the definition of the start conditions, the attainment of any one of the stop criteria leads to the discontinuation of titration. Here, too, combinations are possible and are indeed preferable.

---

<b>Volume</b>	<b>Definition of the stop volume</b> <i>absolute   relative   off</i>
---------------	--

---

The stop volume can be entered as an absolute volume, or as a relative volume as a function of the sample size. Various other fields\* will need to be edited depending on what is entered in this field (see below). Attainment of the stop volume leads to discontinuation of the titration.

---

<b>Size*</b>	<b>Absolute volume</b> (with abs. stop volume) <i>0...99.99...999.99 mL</i>
--------------	--

---

It is preferable to select an absolute stop volume when the primary objective is to prevent the titration vessel from overflowing.

---

<b>Factor*</b>	<b>Calculation factor</b> (with rel. stop volume) <i>-99999...0...99999</i>
----------------	--

---

The actual volume of the stop volume is calculated from:  
**Volume in mL = sample size \* factor.**

It is preferable to select a relative stop volume when the primary objective is to limit the consumption of reagent.

---

**Fill. rate** **Buret fill rate**  
*0.01 mL/min...150 mL/min | max.*

The buret is automatically filled when the titration ends. The maximum fill rate will depend on the size of the buret cylinder used.

<i>Buret cylinder</i>	<i>max. fill rate</i>
1 mL	3 mL/min
2 mL	6 mL/min
5 mL	15 mL/min
10 mL	30 mL/min
20 mL	60 mL/min
50 mL	150 mL/min

A value up to 150 mL/min can be entered even for small buret cylinders. When the method is executed, however, the dosing rate will automatically be reduced to the largest possible value. Select '**max**' whenever possible, except with viscous reagent solutions which could cause underpressure in the cylinder if the filling rate is too fast (formation of bubbles!).

---

**Meas. val** **Measured value as a discontinuation criteria**  
 with DET\_PH: *pH -20 ... 20 | off*  
 with DET\_U, DET\_IPOL: *-2000 ... 2000 mV | off*  
 with DET\_UPOL: *-200 ... 200  $\mu$ A | off*

The measured value at which the titration is discontinued.

---

**EP#** **Number of equivalence points**  
*0...9 | off*

The titration is discontinued as soon as the pre-set number of equivalence points is recognized. In principle, only 9 equivalence points can be evaluated. In the setting '**EP# 0**' the titration is discontinued after the start conditions are executed (initial dosing). '**off**' means, the number of equivalence points found is not taken into account for the discontinuation of a titration.

---

**Stop time** **Absolute titration duration**  
*1...9999 s | off*

The titration is discontinued on expiry of the pre-set stop time.

**Mpt. overflow**                      **Discontinuation: full measuring point list**  
*on | off*

If 'on' is selected, titration is discontinued when the measuring point list is full (1000 measuring points).  
 At 'off', titration continues after 1000 measuring points, but no further measuring points are recorded.

### 8.2.2 User adjustments

User adjustments allow fine adjustment of the pre-set titration parameters. Starting from one of the sets of parameters (slow, medium, fast) go to 'Adjustment' in the method editor and press the [Custom adjust] softkey to change the individual parameters in the 'Custom adjustments' dialogue window.

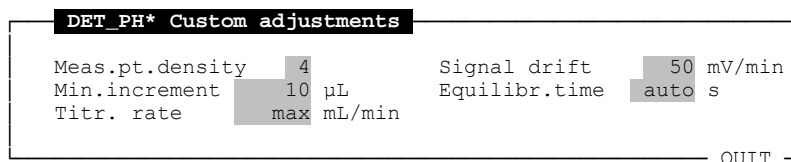

**Meas.pt.density**                      **Meas. pt. density**  
*0...4...9*

The measuring point density is a measure of how often the measuring points are determined during the titration. This parameter has a direct impact on the size of the variable volume steps. A small measuring point density value results in small volume steps, i.e. lots of individual measuring points. A large value results in big volume steps, i.e. fewer measuring points.

**Min.increment**                      **Minimum volume increment**  
*0,1...10...999,99 µL*

To avoid excessively small volume steps with dynamically controlled titrations (and hence "endless" waits), the minimum volume increment can be pre-set. Caution should be exercised when changing this parameter, as excessively large volume steps can adversely affect the accuracy of the results.

**Titr. rate**                              **Titration rate**  
*0,01...150 mL/Min | max*

The titration rate has a direct impact on the dosing rate of the volume increments. The maximum value depends on the buret cylinder size.

<i>Buret cylinder</i>	<i>max. rate</i>
1 mL	3 mL/min
2 mL	6 mL/min
5 mL	15 mL/min
10 mL	30 mL/min
20 mL	60 mL/min
50 mL	150 mL/min

A value up to 150 mL/min can be entered even for small buret cylinders. When the method is executed, however, the dosing rate will automatically be reduced to the largest possible value. Select '**max**' whenever possible, except with viscous reagent solutions.

---

**Signal drift**
**Limits for signal drift**

with DET_PH/U/IPOL:	0,5... <b>50</b> ...999 mV/Min   off
with DET_UPOL:	0,1... <b>50</b> ...100 µA/Min   off

After adding a volume step, the next addition of reagent is not made until the change in the measured value of the sensor falls below the indicated value for the signal drift. If this is delayed, dosing is continued irrespective on expiry of the pre-set equilibration time (see below). This signal drift control can be switched off ('**off**'). When the drift control is switched off, the pre-set waiting time (see below) is strictly adhered to. This can be useful if the titration reaction proceeds slowly or the sensor takes a long time to respond.

---

**Equilibr.time**
**Max. pause before next volume step**

0,1...9999 s | **auto** | off

The full waiting time between one volume increment and the next volume step takes effect when, with the drift control switched on (see signal drift, above), the signal drift does not fall below the pre-set value. Otherwise, dosing is continued after attainment of the signal drift. The full waiting time also takes effect if the drift control is switched off.

The equilibration time function can be switched off. In this mode, the only decisive factor is the signal drift for the titration procedure.

In the '**auto**' mode the Titroprocessor selects an appropriate equilibration time in line with the pre-set signal drift. It is calculated using the following formula:

$$\text{Equilibration time (in s)} = \frac{150}{\sqrt{\text{drift} / (\text{mV} / \text{min}) + 0,01}} + 5$$

For the standard 50 mV setting, this gives a 26 second equilibration time.

### 8.2.3 EP recognition

If there is a possibility of several equivalence points occurring in one titration, correct evaluation will depend on the criteria for recognizing the EPs being correctly set.

EP Recognition									
Equivalence points		window		min. EPC		5.0			
Gen. lower limit		pH min		upp. pH		max			
pK/HNP Evaluation		off							
Windows					Fixendpoints				
EP#	from	...	to	[pH]	EPC	[ ]	F#	M.value	[pH]
1	min		max		5.0		1	off	
2	off		off		5.0		2	off	
3	off		off		5.0		3	off	
4	off		off		5.0		4	off	
5	off		off		5.0		5	off	
6	off		off		5.0		6	off	
7	off		off		5.0		7	off	
8	off		off		5.0		8	off	
9	off		off		5.0		9	off	

QUIT

Equivalence points are evaluated according to the so-called equivalence point criterion (**ERC**), which is calculated with a special algorithm using the 1st derivative (dMV/dV) of the titration curve. It is a measure of the severity of the jump in equivalence and takes greater account of gentler jumps than of steep jumps. The primary criterion for recognizing an equivalence point is the value of the ERC, which must exceed a pre-set threshold value (EP crit.).

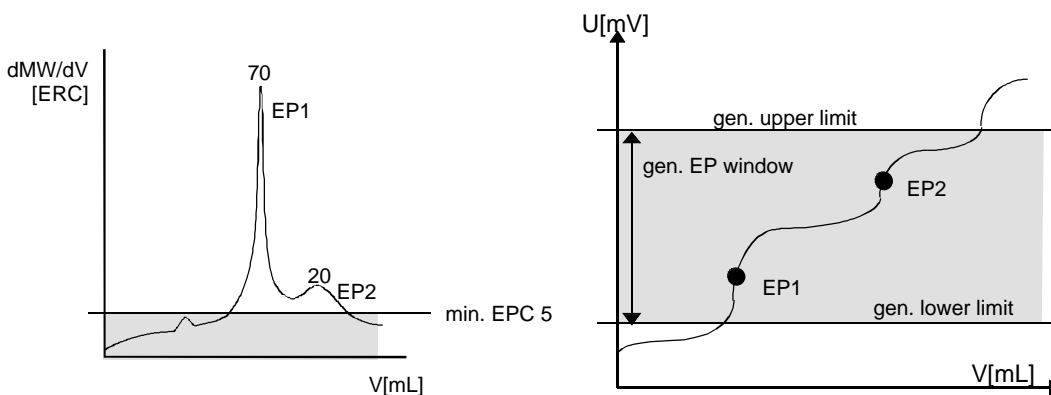

The second criterion for recognizing an equivalence point is the measured value area in which it occurs, the so-called EP window. One can define a general EP window in which EP recognition will proceed in line with specific criteria (such as greatest, last or all EPs).

On the other hand, EP recognition can also take place in several EP windows (measured value areas), to each of which a certain equivalence point is allocated. The EP windows must not overlap.

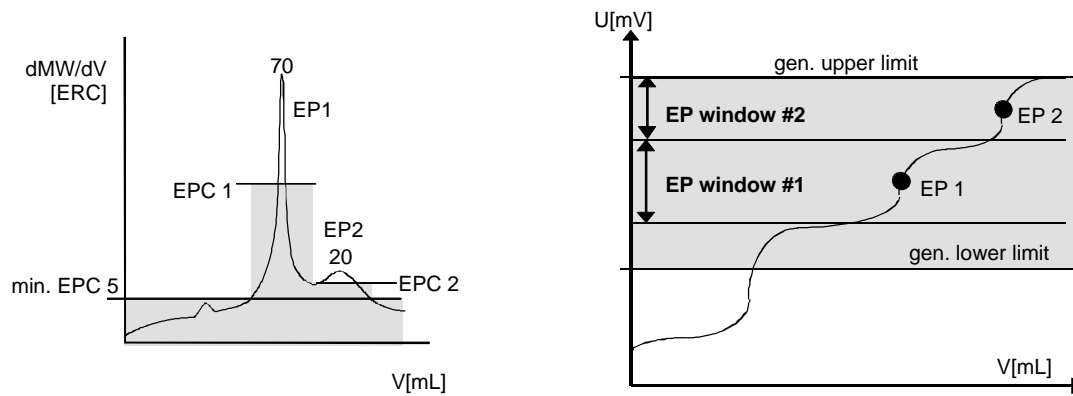

---

**Equivalence points**
**Main setting for EP recognition**
*all | last | greatest | window | off*

With the '**all**', '**last**' and '**greatest**' settings this information relates to the general EP window only. Up to 9 equivalence point windows can be set at '**window**', all of which must be inside the general EP window. The basic setting for the min. EPC applies as the minimum value for the individual EP windows.

---

**min. EPC**
**General equivalence point criterion**
*0...5...200*

The min. EPC is the lowest EPC value which an equivalence point must fulfill to be recognized as such. This value also applies as the basic setting for the individual EP windows.

---

**Gen. lower limit**
**Lower limit of the gen. EP window**

with DET\_PH\* *pH -20...20 | **min***  
 with DET\_U\*, DET\_IPOL\* *-2000...2000 mV | **min***  
 with DET\_UPOL\* *-200 ...200  $\mu$ A | **min***

For each titration, the evaluation area can be restricted at will by changing the general equivalence point window. Enter the lower limit value here. The evaluation areas of any individual EP windows must be located within the general limits entered.

---

**Gen. upper limit**
**Upper limit of the gen. EP window**

with DET\_PH\* *pH -20...20 | **max***  
 with DET\_U\*, DET\_IPOL\* *-2000...2000 mV | **max***  
 with DET\_UPOL\* *-200 ...200  $\mu$ A | **max***

The upper limit value of the general equivalence point window. Equivalence points can only be evaluated if they lie within the limit values entered.

**pK/HNP Evaluation**      **pK value and half neutralization potential**  
*on / off*

When the pK/HNP evaluation function is switched on, the potential and the associated volume are filed in the **HNP1...9** resp. **HN1...9** system variables. These variables can be used for calculations.

Careful pH calibration is essential for pK and HNP evaluations.

If initial dosing takes place, it must be smaller than 1/2 the dosed volume at the corresponding equivalence point, otherwise the pK or HNP value cannot be evaluated.

**Note!** pK values < 3.5 or > 10.5 must on principle be regarded as unreliable, i.e. inaccurate.

**Windows**      **Individual equivalence point windows**

Individual EP windows can only be entered if 'window' was indicated under 'Equivalence points'.

<b>EP# from ... to[ ]</b>	<b>Limits of the individual EP windows</b>
with DET_PH*	pH -20...20   <i>min</i>   <i>max</i>
with DET_U*, DET_IPOL*	-2000...2000 mV   <i>min</i>   <i>max</i>
with DET_UPOL*	-200 ...200 µA   <i>min</i>   <i>max</i>

Different EP windows can be assigned for the various equivalence points expected. This allows equivalence points to be assigned with greater reliability to the given calculation formulae, and suppresses undesirable EPs. EP windows must not overlap. They must all lie within the limits of the general EP window. The [**Check limits**] softkey is used to check the correctness of the limits.

In any one EP window it is always the first equivalence point found that is recognized. Other EPs are suppressed. On the results page, the corresponding equivalence point is marked with a '+' if there is more than one EP in the corresponding EP window.

**EPC [ ]**      **Equivalence point criterion for EP recognition**  
*0...5...200*

An individual EP criterion can be selected for each EP window. It must, however, always be greater than the EP criterion for the general EP window.

---

**Fix end points**                      **End points with pre-set measured values**

It may be desirable to calculate with a volume value at a fixed measured value on the titration curve. This is where fix end points can be useful.

---

<b>F#</b>	<b>M.value</b>	<b>Measured value of the fixed end point</b>
	with DET_PH*	pH -20...20   <b>off</b>
	with DET_U*, DET_IPOL*	-2000...2000 mV   <b>off</b>
	with DET_UPOL*	-200 ...200 µA   <b>off</b>

Up to nine fix end points can be defined. Upon titration, their associated volume values are filed in the **F1...9 variables** (measured values of the fix end points = > **FM1...9**) and can be used for calculations like normal EPs.

---

### 8.2.4 Curve display

The settings for the curve display are valid for both the live curve display and the curve printout. The measurable variable display for the two axes and their scales can be set individually. Combined curves can also be displayed (not live).

---

<b>Quantity</b>	<b>Y_Axis</b>	<b>Measurable variables on the Y-axis</b>
		<b>M.value</b>   Volume   Temp.   dMW/dV MW,Temp.   MW,dMW/dV   all

Other display options are possible in addition to the standard Measured Value/Volume display. The choice of measurable variables on the Y-axis is as follows:

<i>M.value</i>	pH, mV or µA (in line with mode)
<i>Volume</i>	i.e. volume against time
<i>Temp.</i>	with automatic measurement only
<i>dMW/dV</i>	1st derivative of the measured value curve against volume
<i>MW, Temp.</i>	Meas. value and temp. combined
<i>MW,dMW/dV</i>	Meas. value and 1st derivative against volume, combined
<i>all</i>	all displayable curves combined

---

<b>Quantity X_Axis</b>	<b>Display unit on the X-axis</b> <i>Volume   Time</i>
------------------------	---

Titration curves can be displayed against volume or time. The time axis can only be displayed if the time recording function (see page 135) is switched on.

---

<b>Scale</b>	<b>Type of axis scale</b> <i>auto   fixed</i>
--------------	--

The two axes of the curve display can be automatically scaled by the Titroprocessor. If a fixed scale is required, the operator must indicate all the scaling parameters (see below).

---

<b>begin ... end</b>	<b>Limit values for a fixed scale</b>
Y-axis:	<i>pH -20...20   -2000...2000 mV -200...200 <math>\mu</math>A   ERC 0...200</i>
X-axis:	<i>0...999,99 mL   0...999 999 s</i>

The limit values of the scale can be chosen as required within the limits defined by the measurable variables. If you enter fixed limit values, ensure that the scale function is also set to **'fixed'**.

---

<b>Division</b>	<b>Intervals between scale marks on the X-axis</b> <i>0,01...1...99,9 mL/cm 0,01...10...99,9 s/cm</i>
-----------------	--

The scale division on the X-axis only applies for printing out titration or measuring curves.

---

<b>Grid</b>	<b>Titration curve grid</b> <i>on   off</i>
-------------	--

The titration curve grid can only be viewed when the curve is printed out. It cannot be viewed on the screen.

## 8.3 MET

There is a choice of four different **MET** modes for controlled titrations with fixed volume steps. They differ only with regard to the measuring quantity:

<b>MET_PH*</b>	Measuring quantity pH
<b>MET_U*</b>	Measuring quantity mV
<b>MET_UPOL*</b>	Measuring quantity $\mu\text{A}$ (adjustable pol. voltage in mV)
<b>MET_IPOL*</b>	Measuring quantity mV (adjustable pol. current in $\mu\text{A}$ )

The following information applies to all **MET** modes. Discrepancies are indicated.

**MET\_PH\***

**monotonic equivalence point titration**

Reagent		Sensor	
Concentr.		Meas. input	A1
Dos. drive	A1		

applies for  $\Rightarrow$

**MET\_PH\***, **MET\_U\***, **MET\_UPOL\***, **MET\_IPOL\***

**MET** modes create the same system variables as **DET** modes, see page 129.

### Assignment parameters of the MET modes:

The assignment parameters (comment, reagent ... etc.) of the **MET** modes coincide with those of the **DET** modes, see page 130f.

### 8.3.1 [ \* Param ] Specific parameters for MET modes

The specific parameters of the corresponding **MET** mode will be found under the [ \* Param ] softkey.

MET_PH* Parameters			
Start conditions			
Volume	off	Meas.val. pH	off
Dos. rate	max mL/min	Slope	off pH/mL
		Pause	0 s
Titration conditions			
Adjustment	medium	Time recording	on
Temperature	25.0 °C		
Stop conditions			
Volume	absolute	Meas.val. pH	off
Size	99.99 mL	EP#	9
fill. rate	max mL/min	Stop time	off s
		Mpt. overflow	on
QUIT			

The parameters of the monotonic titration modes coincide with those of the DET modes, see page 131ff.

### 8.3.2 User adjustments

User adjustments allow fine adjustment of the pre-set titration parameters. Starting from one of the sets of parameters (**slow**, **medium**, **fast**) go to 'Adjustment' on the parameter page and press the [Custom adjust] softkey to change the individual parameters in the 'Custom adjustments' dialog window.



---

**Volume steps** **Size of the fixed volume steps**  
0,001...0,1...9,999 mL

The size of the volume steps should be selected carefully, as excessively large volume steps may adversely affect the accuracy of the results. A good guide value for selecting the volume increment is  $\frac{1}{20}$  of the expected EP volume.

---

**Titr. rate** **Titration rate**  
0,01...150 mL/Min | **max**

The titration rate has a direct impact on the dosing rate of the volume increment. The maximum value will depend on the buret cylinder size.

<i>Buret cylinder</i>	<i>max. rate</i>
1 mL	3 mL/min
2 mL	6 mL/min
5 mL	15 mL/min
10 mL	30 mL/min
20 mL	60 mL/min
50 mL	150 mL/min

A value up to 150 mL/min can be entered even for small buret cylinders. When the method is executed, however, the dosing rate will automatically be reduced to the largest possible value. Select 'max' whenever possible, except with viscous reagent solutions.

Signal drift	Limits for signal drift
with MET_PH/U/IPOL:	0,5... <b>50</b> ... 999 mV/Min   off
with MET_UPOL:	0,1... <b>50</b> ... 100 µA/Min   off

After adding a volume step, the next addition of reagent is not made until the change in the measured value of the sensor falls below the indicated value for the signal drift. If this is delayed, dosing is continued irrespective on expiry of the pre-set equilibration time (see below). This signal drift control can be switched off ('off'). When the drift control is switched off, the pre-set waiting time (see below) is strictly adhered to. This can be useful if the titration reaction proceeds slowly or the sensor takes a long time to respond.

Equilibr. time	max. waiting time before next volume step
	0,1... 9999 s   <b>auto</b>   off

The full waiting time between one volume increment and the next volume step takes effect when, with the drift control switched on (see signal drift, above), the signal drift does not fall below the pre-set value. Otherwise, dosing is continued after attainment of the signal drift. The full waiting time also takes effect if the drift control is switched off.

The equilibration time function can be switched off. In this mode, the only decisive factor is the signal drift for the titration procedure. In the '**auto**' mode the Titroprocessor selects an appropriate equilibration time in line with the pre-set signal drift value. It is calculated using the following formula:

$$\text{Equilibration time (in s)} = \frac{150}{\sqrt{\text{drift} / (\text{mV} / \text{min}) + 0,01}} + 5$$

For the standard 50 mV setting this results in a 26 second equilibration time.

### 8.3.3 EP Recognition

If there is a possibility of several equivalence points occurring in one titration, it is essential for a correct evaluation that the criteria for recognizing the EPs be correctly set.

The parameters of EP recognition for the monotonic titration modes coincide with those of the **DET** modes, see page 139ff.

As the ERC is calculated differently for a monotonic titration, this results in a different range of validity for the EP criterion, see next page.

EP Recognition									
Equivalence points		window		min. EPC pH		0.500			
Gen. lower limit		pH min		upp. pH		max			
pK/HNP Evaluation		off							
Windows					Fixendpoints				
EP#	from ...	to	[pH]	EPC	[ ]	F#	M.value	[pH]	
1	min	max		5.0		1	off		
2	off	off		5.0		2	off		
3	off	off		5.0		3	off		
4	off	off		5.0		4	off		
5	off	off		5.0		5	off		
6	off	off		5.0		6	off		
7	off	off		5.0		7	off		
8	off	off		5.0		8	off		
9	off	off		5.0		9	off		

QUIT

**min. EPC**

**General equivalence point criterion**

0,1...0,5...9,999

The EP criterion is the lowest EPC value which an equivalence point must fulfil to be recognized as such. This value also applies as the basic setting for the individual EP windows.

**How to determine an EPC of an endpoint in METmode:**

- Print out the measuring point list of the titration in question.
- Find the greatest change in the measured value -->  $D_n$ .
- The EPC value is the sum of the five measured value changes near  $D_n$  (before and after  $D_n$ ). Use unsigned values.
- If both negative and positive measured value changes are found near  $D_n$ , add up 3 value changes only. Use unsigned values anyway.

To suppress an EP, apply an EPC greater than the value estimated and re-calculate the results.  
To accept an EP, but suppress all minor EPs, choose an EPC less than the value estimated.

**EPC [ ]**

**Equivalence point criterion for EP recognition**

0,1...0,5...9,999

An individual EP criterion can be selected for any EP window. It must, however, always be greater than the EP criterion for the general EP window.

### 8.3.4 Curve display

The settings for the curve display are valid for both the live curve display and the curve printout. The measurable variable display for the two axes and their scale divisions can be set individually. Combined curves can also be displayed (not live).

The possible settings of the curve display for **MET** titrations coincide with those for the **DET** modes, except for the display of the derived curve, which is not possible here (see below).

Quantity Y_Axis	Measurable variable on the Y-axis
	<i>M. value</i>   <i>Volume</i>   <i>Temp.</i>   <i>dMW/dV</i>
	<i>MW, Tem.p</i>   <i>MW, dMW/dV</i>   <i>all</i>

Other display options are possible in addition to the standard Measured Value/Volume display. The choice of measuring quantities on the Y-axis is as follows:

<i>M.value</i>	pH, mV or $\mu\text{A}$ (in line with mode)
<i>Volume</i>	i.e. volume against time
<i>Temp.</i>	automatic measurement only
<i>MW, Temp.</i>	Meas. value and temp. combined
<i>all</i>	all displayable curves combined

## 8.4 SET

Four different **SET** modes are available for rapid controlled titrations to a preset endpoint; they differ only in the measured quantity or the measuring mode:

- SET\_PH\*** measured quantity pH
- SET\_U\*** measured quantity mV
- SET\_UPOL\*** measured quantity  $\mu\text{A}$  (selectable pol. voltage in mV)
- SET\_IPOL\*** measured quantity mV (selectable pol. current in  $\mu\text{A}$ )

The following information applies to all **SET** modes. Any discrepancies are noted.

SET\_PH\*

Titration to preset endpoint	
Reagent	Sensor
Concentr.	Meas. input A1
Dos. drive	A1

applies to  $\Rightarrow$  SET\_PH\*, SET\_U\*, SET\_UPOL\*, SET\_IPOL\*

**SET** modes create the same system variables as **DET** modes, see page 129. In addition the following variables are provided for calculating a drift volume reduction (see page 155):

- DOD** Dosing duration during the titration, cumulative
- ITD** Time duration between conditioning and titration

### Assignment parameters for SET modes:

The assignment parameters (Comment, Reagent, etc.) for the **SET** modes are the same as those for the **DET** modes, see page 130f.

### 8.4.1 Specific parameters for SET modes [\* Param ]

The specific parameters for the respective **SET** mode can be found under the softkey [**\* Param**].

SET_PH* Parameters	
Start conditions	
Volume	off
Pause 1	0 s
Pause 2	0 s
Extract.time	0 s
Titration conditions	
Direction	auto
End-point	pH
Adjustment	medium
Mpt. interval	off s
Temperature	25.0 °C
Time recording	on
Derivation	off
Stop conditions	
Volume	absolute
Size	99.99 mL
Fill. rate	max mL/Min
Stop time	off s
Mpt. overflow	off

QUIT

---

**Start conditions**

The start conditions correspond to those of the **KFT** mode, see page 160f.

---

**Titration conditions**

These are the actual titration parameters which control the measurement recording and the dosing behavior during the titration itself.

---

<b>Direction</b>	<b>Direction of the potential jump</b> <i>pos.   neg.   auto</i>
------------------	---

The direction of the potential jump is important for titration control in the SET mode. Normally the '**auto**' setting should be used. The titration direction is then determined from the initial measured value and preset target endpoint. The titration direction can also be fixed in advance. The possible settings '**pos.**' and '**neg.**' refer to the numerical measured value alterations.

---

<b>End-point</b>	<b>Target endpoint</b>
for SET_PH*	<i>pH -20...20</i>
for SET_U*, SET_IPOL*	<i>-2000...2000 mV</i>
for SET_UPOL*	<i>-200 ...200 µA</i>

The target endpoint defines the measured value which the titration control is aiming for. The endpoint should have been previously determined by a dynamic (DET) titration before the method is drawn up. Correct calibration of the sensor used is highly recommended.

---

<b>Adjustment</b>	<b>Predefined parameter sets</b> <i>slow   medium   fast</i>
-------------------	---

A selection can be made from three different sets of parameters for the simplified setting of the titration parameters. Each of these sets includes proven controller settings which are suitable for most requirements.

- |               |  |
|---------------|--|
| <i>slow</i>   | for chemically inhibited reactions requiring a longer period of time, or if the EP has to be located in a steep section of the curve |
| <i>medium</i> | standard parameters for unproblematic titrations, optimized for the commonest applications   |
| <i>fast</i>   | speed-optimized control parameters for non-critical titrations where no steep potential jumps are expected                           |

If the titration parameters have to be adapted for specific titration problems the different control parameters can be altered individually.

The [**Custom adjust**] softkey opens a further dialog window in which user-defined settings can be carried out (see page 152f).

---

<b>Mpt. interval</b>	<b>Interval between measurement recordings</b> <i>1...9999 s   off</i>
----------------------	---

A measurement point interval must be entered for showing curves and display of the live value of a SET titration. The measurement data will always be entered in the measuring point list at these intervals. At the same time the presentation of the curve and the calculation of the live value are updated. If the measuring point interval is switched off no measuring point list will be drawn up.

---

<b>Temperature</b>	<b>Temperature setting or measuring mode</b> <i>-170...25.0...500°C   auto   initial</i>
--------------------	---

The temperature can be automatically determined during a titration with the aid of a Pt100/Pt1000 sensor or a combined electrode with built-in temperature sensor and can be used for automatic pH correction (if pH is being measured). It is possible to record the temperature throughout a titration and to output it as a temperature curve.

<i>numerical</i>	manual input (e.g. for pH correction)
<i>auto</i>	automatic measurement during the whole titration (for temperature curve)
<i>initial</i>	one-off measurement at the start of the titration mode

The temperature can be included in formulas for calculations (see page 119ff), e.g. for volume corrections. The different system variables are listed on page 149 and 129.  
**Please note:** start temperature **ST** and closing temperature **CT** are only available with *auto*.

---

<b>Time recording</b>	<b>Recording the measurement time</b> <i>on   off</i>
-----------------------	--

For recording the titration curve on the time axis the time recording function must be switched on. If the titration curve is drawn on the volume axis time recording can be switched off. This permits smaller determination files as fewer measurements are made and stored.

---

**Derivation**      **Recording the 1st derivative of the titration curve**  
*on | off*

If the derivative of the titration curve is to be shown then derivation recording must be switched on.

---

**U(po1)**      **Polarization voltage** (only with **SET\_UPOL\***)  
*-1270...400...1270 mV*

The polarization voltage is the voltage which is applied to a polarized electrode during amperometric titration. The resultant measuring quantity is  $\mu\text{A}$ .

---

**I(po1)**      **Polarization current** (only with **SET\_IPOL\***)  
*-127...1...127  $\mu\text{A}$* 

The polarization current is the current which is applied to a polarized electrode during voltametric titration. The resultant measuring quantity is mV.

---

**Stop conditions**

The stop conditions correspond to those of the **KFT** mode, see page 163f.

---

### 8.4.2 Custom Adjustments

Custom adjustments allow the control parameters of the titration to be finely tuned. Starting with a set of parameters (fine, medium, coarse) after pressing the softkey [**User defin.**] under '**Adjustments**' on the parameter page the individual parameters can be altered in the dialog window 'Custom adjustments'.

Custom adjustments					
Dynamics	pH	2.00			
Min. rate		25.00	$\mu\text{L}/\text{min}$	Stop crit.	drift
Max. rate		10.00	$\text{mL}/\text{min}$	Stop drift	20 $\mu\text{L}/\text{min}$
					QUIT

---

**Dynamics**      **Measurement range for controlled titration**  
 for SET\_PH:      *0.1...2...20 | off*  
 for SET\_U, SET\_IPOL:      *1...100.0...2000 mV | off*  
 for SET\_UPOL:      *0.1...10.0...200.0  $\mu\text{A}$  | off*

The control range defines the measurement range in which controlled titration is carried out before the given endpoint. Outside this range addition is made at the maximum dosing rate. For steep curves a sufficiently large control range should be selected; for flatter curves this can be smaller. If the control range is switched off

controlled addition will be carried out throughout the whole titration.

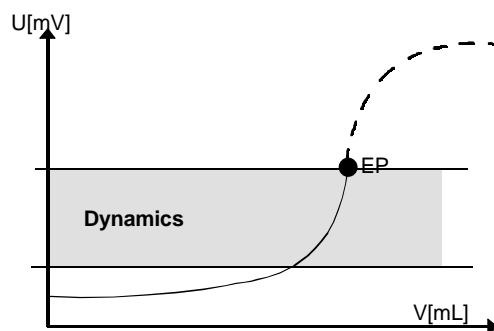

**Min. rate**

**Smallest possible titration speed**

*0.01...25...999.9  $\mu\text{L}/\text{min}$  | min.*

In order to avoid excessively slow titration speeds (and thus "never-ending" waiting times) during dynamically controlled titrations the smallest possible titration speed can be set. This parameter should only be altered with caution, as too rapid reagent addition can negatively influence the accuracy of the results.

**Max. rate**

**Largest possible titration speed**

*0.01...10.00...150 mL/min | max*

Setting the max. rate has a direct effect on the dosing speed of the titration control. The maximal value depends on the cylinder size of the buret.

<i>Buret cylinder</i>	<i>max. speed</i>
1 mL	3 mL/min
2 mL	6 mL/min
5 mL	15 mL/min
10 mL	30 mL/min
20 mL	60 mL/min
50 mL	150 mL/min

A value up to 150 mL/min can also be entered for smaller buret cylinders; however, when the method is carried out the dosing speed will automatically be reduced to the largest possible value. Whenever possible 'max' should be selected, except for viscous reagent solutions.

**stop crit.**
**Switch-off mode**  
*Drift | time | none*

The stop criterion defines the behavior of the titrator when the endpoint is reached. The automatic termination of the titration can be carried out according to different criteria:

- |              |   |
|--------------|---|
| <i>Drift</i> | The titration is stopped when (after the EP has been reached) the volume drift falls below the set value. |
| <i>Time</i>  | After the EP has been reached the set time is allowed to elapse before the titration is stopped.          |
| <i>none</i>  | The titration will not be stopped automatically. The sample solution will be kept at the endpoint.        |

If a renewed addition is necessary before the stop criterion is recognized then a further volume increment will be added and the stop criterion again checked.

**stop drift**
**Volume drift for titration termination**  
*1...20...999  $\mu\text{L}/\text{min}$* 

After the last addition (...and after the EP has been reached) the stop drift must be undercut before the titration can be ended. This volume drift can be interpreted as being the dosing rate which is theoretically required to keep the measured value of the sample solution constant at the endpoint.

**t(delay)**
**Delay before titration termination**  
*0...9999 s*

When the EP has been reached the set time is allowed to elapse before the titration is ended. If the delay time is set as '0 s' then the titration will be terminated immediately the EP has been reached.

### 8.4.3 Curve display with SET

The settings for the curve display correspond to those for the KFT mode, see page 167.

## 8.5 SEC

Conditioning to a preset endpoint is implemented as an independent mode. Its own set of parameters makes the conditioning mode **SEC** independent from **SET** modes. In this way conditioning is very versatile.

A **SEC** mode does not produce a measuring point list and therefore no curves can be shown. No facilities for calculations are provided.

If a **SEC** mode is used in preparation for a **SET** titration then care must be taken that the parameters of both modes do not differ too much from each other.

Four different **SEC** modes are available for rapid conditioning to a preset endpoint; they differ only in the measured quantity:

<b>SEC_PH*</b>	measured quantity pH
<b>SEC_U*</b>	measured quantity mV
<b>SEC_UPOL*</b>	measured quantity $\mu$ A (selectable pol.voltage in mV)
<b>SEC_IPOL*</b>	measured quantity mV (selectable pol.current in $\mu$ A)

The following information applies to all **SEC** modes. Any variations are noted.

**SEC\_PH\***

**Conditioning to preset endpoint**

Reagent	Sensor	
Concentr.	Meas. input	A1
Dos. drive	A1	

applies to  $\Rightarrow$  **SEC\_PH\***, **SEC\_U\***, **SEC\_UPOL\***, **SEC\_IPOL\***

**SEC** modes create the following system variables:

<b>COV</b>	Conditioning volume; reagent consumption for conditioning
<b>DRC</b>	Volume drift in conditioned state
<b>\$CRF</b>	Conditioning flag; correctly conditioned yes/no (1 or 0)

These system variables can be used to apply an automatic drift volume reduction:

Formula:

<b>Drift red.</b>	$R1 = DRC / 60 * (ITD + MD) / 1000$	mL
<b>EP corr.</b>	$R2 = EP1 - R1$	mL

Here it is assumed that owing to external influences a volume drift is effective during the sample titration whose value corresponds to the volume drift in a conditioned state (variable **DRC**). Its duration is equivalent to the period between conditioning switch-off and sample titration switch-off (**ITD + MD \***).

- \* **ITD**= Intermediate titration duration, time between conditioning switch-off and the start of the next titration in s.  
**MD**= Mode duration, sample titration time in s.

### Assignment parameters for SEC modes:

The assignment parameters (Comments, Reagent ... etc.) for the **SEC** modes are the same as those of the **DET** modes, see page 130f.

## 8.5.1 Specific parameters for SEC modes [ \* Param ]

The specific parameters for the respective **SEC** mode can be found under the softkey [ \* Param ].

SEC_PH* Parameters	
Titration conditions	
Direction	auto
End-point pH Adjustment	medium
Temperature	25.0 °C
Fill. rate	max mL/min
QUIT	

### Titration conditions

These are the actual titration parameters which control the measurement recording and the dosing behavior during the titration itself.

#### Direction

**Control direction**  
*pos. | neg. | auto*

The control direction must be entered for titration control in the SEC mode. Normally the '**auto**' setting should be used. The control direction is then determined from the initial measured value and preset target endpoint. The control direction can also be fixed in advance. The possible settings '**pos.**' and '**neg.**' refer to the numerical measured value alterations.

#### End-point

#### Target endpoint

for SEC_PH*	<i>pH -20...20</i>
for SEC_U*, SEC_IPOL*	<i>-2000...2000 mV</i>
for SEC_UPOL*	<i>-200 ...200 µA</i>

The target endpoint defines the measured value which the conditioning control is aiming for. Correct calibration of the sensor used is highly recommended.

---

**Adjustment**
**Predefined parameter sets**
*slow* | **medium** | *fast*

A selection can be made from three different sets of parameters for the simplified setting of the titration parameters. Each of these sets includes proven controller settings which are suitable for most requirements.

*slow* for extremely accurate titrations or for chemically inhibited reactions requiring a lot of time

*medium* standard parameters for unproblematic titrations, optimized for the commonest applications

*fast* speed-optimized control parameters for non-critical titrations

If the titration parameters have to be adapted for specific titration problems the different control parameters can be altered individually.

The [**Custom adjust**] softkey opens a further dialog window in which user-defined settings can be carried out (see page 152).

---

**Fill. rate**
**Buret filling speed**
*0.01 mL/min...150 mL/min* | **max.**

At the end of a titration the buret is automatically filled. The maximum value for the filling rate depends on the cylinder size of the buret used.

<i>Buret cylinder</i>	<i>max. speed</i>
1 mL	3 mL/min
2 mL	6 mL/min
5 mL	15 mL/min
10 mL	30 mL/min
20 mL	60 mL/min
50 mL	150 mL/min

A value up to 150 mL/min can also be entered for smaller buret cylinders; however, when the method is carried out the dosing speed will automatically be reduced to the largest possible value. Whenever possible 'max' should be selected, except for viscous reagent solutions for which too rapid filling can cause a partial vacuum in the cylinder (bubble formation!).

---

**Temperature**
**Temperature setting or measuring mode**
*-170...25.0...500°C* | *auto* | *initial*

The temperature can be automatically determined during a titration with the aid of a Pt100/Pt1000 sensor or a combined electrode with built-in temperature sensor and can be used for automatic pH correction (if pH is being measured). It is possible to record the temperature throughout a titra-



## 8.6 KFT

Two different **KFT** modes are available for titrimetric water determination with Karl Fischer reagents; they differ only in the measuring method:

- KFT\_UPOL\*** measured quantity  $\mu\text{A}$  (selectable pol.voltage in mV)
- KFT\_IPOL\*** measured quantity mV (selectable pol.current in  $\mu\text{A}$ )

The following information applies to both **KFT** modes. Any variations are noted.

**KFT\_IPOL\***

Karl Fischer titration	
Reagent	Sensor
Concentr.	Meas. input Apol
Dos. drive	A1

applies to  $\Rightarrow$  **KFT\_IPOL\***, **KFT\_UPOL\***

**KFT** modes produce the same system variables as **DET** modes, see page 129. In addition the following variables are provided for calculating a drift volume reduction (see page 155):

- DOD** Dosing duration during the titration, cumulative
- ITD** Time duration between conditioning and titration

### Assignment parameters for KFT modes:

The assignment parameters (Comment, Reagent, etc.) for the **KFT** modes are the same as those for the **DET** modes, see page 129f.

### 8.6.1 Specific parameters for KFT modes [ \* Param ]

The specific parameters for the respective **KFT** modes can be found under the softkey [ \* Param ].

KFT_IPOL* Parameters	
Start conditions	
Volume	off
Pause 1	0 s
Pause 2	0 s
Extract.time	0 s
Titration conditions	
Direction	neg.
End-point	250 mV
Adjustment	medium
Meas.interval	off s
Temperature	25.0 °C
Time recording	on
Derivation	off
I (pol)	50 $\mu\text{A}$
Stop conditions	
Volume	absolute
Size	99.99 mL
Fill. rate	max mL/min
Stop time	off s
Mpt. overflow	off

QUIT

---

**Start conditions**

Here the conditions which must be fulfilled for the start of the titration are defined.

Waiting times (Pause1 and Pause 2) can be programmed before and after the addition of a defined start volume (absolute or relative volume depending on the sample weight). The minimum duration of a **KFT** titration as a whole can be defined with the extraction time.

---

**Volume**
**Definition of start volume**

*absolute | relative | off*

The defined start volume can be entered as an absolute volume or as a relative volume depending on the sample weight (this is recommended). Depending on the entry in this field various other input fields need to be edited (see below). The effective added volume is stored in the system variable **SV** and is available for calculations.

---

**size\***
**Absolute volume** (with abs. start volume)

*0...999.99 mL*

When entering an absolute start volume care must be taken that the start volume is kept small enough so that a sufficiently large volume range is available up to the endpoint for the dynamically controlled titration.

---

**Factor\***
**Calculation factor** (with rel. start volume)

*-99999...0...99999*

The effective value for the volume of the start volume addition is calculated from:

$$\text{Volume in mL} = \text{Sample size} * \text{Factor.}$$

The maximum start volume which can be added is 1000 mL. If a larger value is obtained from the calculation then the start volume will be automatically reduced to 1000 mL.

---

**Dos. rate**
**Dosing speed for preliminary dosing**

*0.01 mL/min...150 mL/min | max.*

The maximum dosing rate value depends on the cylinder size of the buret used.

<i>Buret cylinder</i>	<i>max. speed</i>
1 mL	3 mL/min
2 mL	6 mL/min
5 mL	15 mL/min
10 mL	30 mL/min
20 mL	60 mL/min
50 mL	150 mL/min

A value up to 150 mL/min can also be entered for smaller

buret cylinders; however, when the method is carried out the dosing speed will automatically be reduced to the largest possible value.

---

**Pause 1** **Delay before start of preliminary dosing**  
0 ... 9999 s

Before the preliminary dosing is started a delay period can be allowed to elapse. This can be used, for example, to ensure that a sample is completely dissolved in a solvent.

---

**Pause 2** **Delay before the start of the controlled titration**  
0 ... 9999 s

Before the controlled titration is started a delay period can be allowed to elapse. If a preliminary dosing has been carried out then the delay period will start when the preliminary dosing has been concluded. This option should be used when a sample requires a certain reaction time in order to start the titration reaction.

---

**Extract. time** **Minimum duration of a titration**  
0 ... 9999 s

If a sample is difficult to dissolve it is recommended that an extraction time is defined to ensure that a **KFT** titration is not concluded until at least the extraction time has elapsed. This means that if an endpoint is reached prematurely then during the extraction time – if necessary – the preset measuring value for the endpoint will continue to be held.

---

### Titration conditions

These are the actual titration parameters which control the measurement recording and the dosing behavior during the titration itself.

---

**Direction** **Direction of potential jump**  
*pos. | neg. | auto*

The direction of the alteration in the measurements is important for titration control in the **KFT** mode. Normally the '**neg.**' setting should be used. The '**pos.**' and '**neg.**' settings refer to the numerical measured value alterations. The potential jump direction can also be determined automatically. The potential jump direction is then obtained from the initial measured value and the preset target endpoint.

End-point	Target endpoint
for KFT_IPOL*	-2000... <b>250</b> ...2000 mV
for KFT_UPOL*	-200... <b>25</b> ...200 $\mu$ A

The target endpoint defines the measured value which the titration control is aiming for. The standard settings (250 mV or 25  $\mu$ A) are ideal in most cases and should only be altered in exceptional cases. See also page 111ff.

Adjustment	Predefined parameter sets <i>slow</i>   <b>medium</b>   <i>fast</i>
------------	--

A selection can be made from three different sets of parameters for the simplified setting of the titration parameters. Each of these sets includes proven controller settings which are suitable for most requirements.

- slow* for low water content or samples which only release their moisture slowly
- medium* standard parameters for unproblematic titrations, optimized for the commonest applications
- fast* for high water content of non-critical samples

If the titration parameters have to be adapted for specific titration problems the various control parameters can be altered individually.

The [**Custom adjust**] softkey opens a further dialog window in which user-defined settings can be carried out (see page 165).

Meas. interval	Interval between measurement recordings <i>1...9999 s</i>   <b>off</b>
----------------	---

A measurement point interval must be entered for showing curves and display of the live value of a **KFT** titration. The measurement data will always be entered in the measuring point list at these intervals. At the same time the presentation of the curve and the calculation of the live value are updated. If the measuring point interval is switched off no measuring point list will be drawn up.

Temperature	Temperature setting or measuring mode <i>-170...25.0...500°C</i>   <b>auto</b>   <i>initial</i>
-------------	--

The temperature can be automatically determined during a titration with the aid of a Pt100/Pt1000 sensor or a combined electrode with built-in temperature sensor. It is pos-

sible to record the temperature throughout a titration and to output it as a temperature curve.

<i>numerical</i>	manual input
<i>auto</i>	automatic measurement during the whole titration (for temperature curve)
<i>initial</i>	one-off measurement at the start of the titration mode

The temperature can be included in formulas for calculations (see page 119ff), e.g. for volume corrections. The different system variables are listed on page 149 and 129.

**Please note:** Start temperature **ST** and closing temperature **CT** are only available with *auto*.

---

<b>Time recording</b>	<b>Recording the measurement time</b> <i>on   off</i>
-----------------------	--

For recording the titration curve on the time axis the time recording function must be switched on. If the titration curve is drawn on the volume axis time recording can be switched off. This permits smaller determination files as fewer measurements are made and stored.

---

<b>Derivation</b>	<b>Recording the first derivative of the titration curve</b> <i>on   off</i>
-------------------	---

If the derivative of the titration curve is to be shown then derivation recording must be switched on.

---

<b>U(pol)</b>	<b>Polarization voltage</b> (with <b>KFT_UPOL*</b> ) -1270... <b>400</b> ...1270 mV
---------------	--

The polarization voltage is the voltage which is applied to a polarized electrode during amperometric titration. The resultant measuring quantity is  $\mu\text{A}$ .

---

<b>I(pol)</b>	<b>Polarization current</b> (with <b>KFT_IPOL*</b> ) -127... <b>50</b> ...127 $\mu\text{A}$
---------------	--

The polarization current is the current which is applied to a polarized electrode during voltametric titration. The resultant measuring quantity is mV.

---

**Stop conditions**

The stop conditions define when and how a titration is to be concluded. Reaching one of the possible stop criteria causes the titration to be concluded. Combinations of stop conditions are possible and may even be advantageous.

---

**Volume** **Definition of the stop volume**  
*absolute | relative | off*

The stop volume can be entered as an absolute volume or as a relative volume, depending on the sample weight. Depending on the entry in this field various other input fields may need to be edited (see below). When the stop volume is reached the titration is ended.

---

**Size** **Absolute volume** (with abs. stop volume)  
*0...99.99...999.99 mL*

The selection of an absolute stop volume is preferred when the main consideration is ensuring that the titration vessel does not overflow.

---

**Factor** **Calculation factor** (with rel. stop volume)  
*-99999...0...99999*

The effective value for the stop volume is calculated from:  
**Volume in mL = Sample size \* Factor.**

The selection of a relative stop volume is preferred when the main consideration is to limit titrant consumption.

---

**Fill. rate** **Buret filling speed**  
*0.01 mL/min...150 mL/min | max.*

At the end of a titration the buret is automatically filled. The maximum value for the filling rate depends on the cylinder size of the buret used.

<i>Buret cylinder</i>	<i>max. speed</i>
1 mL	3 mL/min
2 mL	6 mL/min
5 mL	15 mL/min
10 mL	30 mL/min
20 mL	60 mL/min
50 mL	150 mL/min

A value up to 150 mL/min can also be entered for smaller buret cylinders; however, when the method is carried out the dosing speed will automatically be reduced to the largest possible value. For KF reagents (viscous liquids) no filling rate greater than 30 mL/min should be selected as otherwise too rapid filling may cause a partial vacuum in the cylinder (bubble formation!).

**Stop time** **Absolute titration duration**  
1...9999 s | **off**

The titration will be terminated when the defined stop time has elapsed.

**Mpt. overflow** **Termination when measuring point list is full**  
**on** | off

If 'on' is selected the titration will be terminated when the measuring point list is full (1000 measuring points). When 1000 measuring points have been reached with 'off' the titration will be continued but no further measuring points will be recorded.

### 8.6.2 Custom adjustments

Custom adjustments allow the control parameters of the titration to be finely tuned. Starting with a set of parameters (fine, medium, coarse) after pressing the softkey [User defin.] under 'Adjustments' on the parameter page the individual parameters can be altered in the dialog window 'Custom adjustments'.

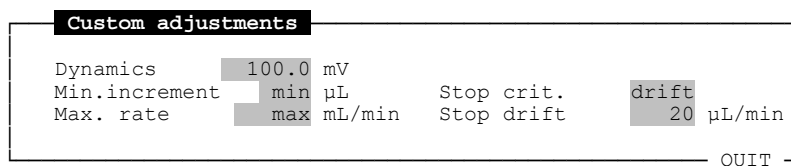

**Dynamics** **Measurement range for controlled titration**  
for KFT\_IPOL: 1...100.0...2000 mV | off  
for KFT\_UPOL: 0.1...10.0...200.0 µA | off

The control range defines the measurement range in which controlled titration is carried out before the given endpoint. Outside this range addition is made at the maximum dosing rate. For KF titrations the use of the proven standard settings is recommended. If the control range is switched off controlled addition will be made throughout the whole titration.

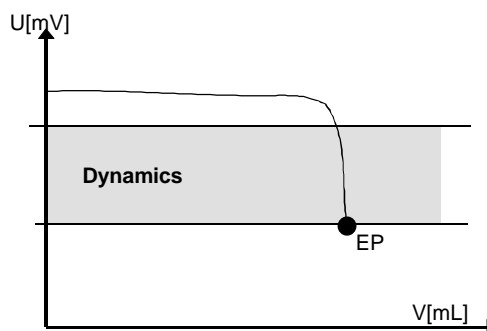

---

**Min. increment** **Smallest possible volume step**  
*0.1...9.99  $\mu$ L | min*

In order to avoid excessively slow titration speeds (and thus "never-ending" waiting times) during dynamically controlled titrations the smallest possible volume increment can be set. This parameter should only be altered with caution, as too large volume increments can negatively influence the accuracy of the results.

---

**Max. rate** **Largest possible titration speed**  
*0.01...150 mL/min | max*

Setting the max. rate has a direct effect on the dosing speed of the titration control. The maximal value depends on the cylinder size of the buret.

<i>Buret cylinder</i>	<i>max. speed</i>
1 mL	3 mL/min
2 mL	6 mL/min
5 mL	15 mL/min
10 mL	30 mL/min
20 mL	60 mL/min
50 mL	150 mL/min

A value up to 150 mL/min can also be entered for smaller buret cylinders; however, when the method is carried out the dosing speed will automatically be reduced to the largest possible value.

---

**Stop crit.** **Switch-off mode**  
*drift | time | none*

The stop criterion defines the behavior of the titrator when the endpoint is reached. The automatic termination of the titration can be carried out according to different criteria:

- Drift*      The titration is stopped when (after the EP has been reached) the volume drift falls below the set value.
- Time*        After the EP has been reached the set time is allowed to elapse before the titration is stopped.
- none*         The titration will not be stopped automatically. The sample solution will be kept at the endpoint.

If a renewed addition is necessary before the stop criterion is recognized then a further volume increment will be added and the stop criterion again checked.

---

<b>Stop drift</b>	<b>Volume drift for titration termination</b> <i>1...20...999 <math>\mu\text{L}/\text{min}</math></i>
-------------------	--

After the last addition (...and after the EP has been reached) the stop drift must be undercut before the titration can be ended. This volume drift can be interpreted as being the dosing rate which is theoretically required to keep the measured value of the sample solution constant at the endpoint.

---

<b>t (delay)</b>	<b>Delay before titration termination</b> <i>0...9999 s</i>
------------------	--

When the EP has been reached the set time is allowed to elapse before the titration is ended. If the delay time is set as '0 s' then the titration will be terminated immediately the EP has been reached.

### 8.6.3 Curve display with KFT

---

The settings for the curve displays are valid for both the live curve display and the curve printout. Curve presentation is only possible when a measuring interval has been entered so that the curve is updated each time this time interval has elapsed.

The representation of the measuring quantities on both axes as well as their scales can be individually fixed. The presentation of combined curves is also possible (but not live).

The possible curve display settings for the **KFT** titrations are the same as those for **DET** modes. In addition, curves derived according to time can be shown, see below.

---

<b>Quantity Y-Axis</b>	<b>Measuring quantities on the Y-axis</b> <i>M.value   Volume   Temp.   dMV/dV dMV/dt   dV/dt   MV,Temp   MV,dMV/dV   all</i>
------------------------	--

As well as the standard representation of measured value/volume other representations are possible. Selection of measuring quantities on the Y-axis:

<i>M.value</i>	pH, mV or $\mu\text{A}$ (depends on mode)
<i>Volume</i>	i.e. volume against time
<i>Temp.</i>	only for automatic measurements
<i>MV, Temp.</i>	measured value and temp.
	combined
<i>dMV/dV</i>	measured value derived from volume
<i>dMV/dt</i>	measured value derived from time
<i>dV/dt</i>	added volume derived from time
<i>MV,dMV/dV</i>	measured value, and measured value derived from volume, combined
<i>all</i>	all representable curves, combined

## 8.7 KFC

Conditioning for a Karl Fischer titration is implemented as an independent mode. The **KFC** mode has its own set of parameters. The settings for conditioning and the titration itself should, if possible, not differ too much from each other.

A **KFC** mode does not produce a measuring point list and therefore no curves can be shown. No facilities for calculations are provided.

Conditioning is normally carried out in the background, i.e. as soon as the conditioning mode has been started the 796 Titroprocessor can carry out other commands (e.g. **CRTL\_RS1**, etc.). A conditioning process also remains active even when a determination has been completed, provided that it has not been explicitly terminated, see below.

A conditioning mode carried out in the background is controlled by the **WAIT\_C** command (see page 209f). This checks whether the conditioned has been achieved and, if necessary, switches the conditioning mode off.

**Example:**

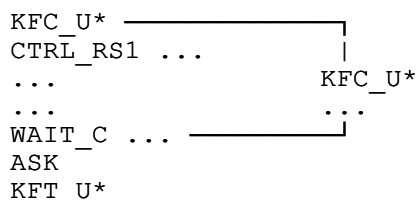

The **WAIT\_C** command synchronizes the background conditioning process with the method being carried out in the foreground. The **WAIT\_C** command interrupts the regular method run until the background process (conditioning) has been completed.

**Note!** Every titration, measuring or calibration mode also terminates background conditioning. Achievement of the conditioned state is not taken into account.

Two **KFC** modes are available for conditioning to a preset endpoint; these differ in the measured quantity or measuring mode:

- KFC\_UPOL\*** measured quantity  $\mu\text{A}$  (selectable pol.voltage in mV)
- KFC\_IPOL\*** measured quantity mV (selectable pol.current in  $\mu\text{A}$ )

The following information applies to all **KFC** modes. Any variations are noted.

**KFC\_IPOL\***

conditioning for Karl Fischer titration			
Reagent		Sensor	
Concentr.		Meas. input	Apol
Dos. drive	A1		

applies to  $\Rightarrow$  **KFC\_UPOL\***, **KFC\_IPOL\***

**KFC** modes produce the following system variables:

**COV** conditioning volume; reagent consumption for conditioning  
**DRC** volume drift in conditioned state (µL/min)  
**\$CRF** conditioning flag; correctly conditioned yes/no (1 or 0)

These system variables can be used to apply an automatic drift volume reduction:

Formula:

**Drift red.**  $R1 = DRC / 60 * (ITD + MD) / 1000$  mL  
**EP corr.**  $R2 = EP1 - R1$  mL

Here it is assumed that owing to external influences a volume drift is effective during the sample titration and whose value corresponds to the volume drift in a conditioned state (variable **DRC**). Its duration is equivalent to the period between conditioning switch-off and sample titration switch-off (**ITD + MD** \*).

\* **ITD**= Intermediate titration duration, time between conditioning switch-off and the start of the next titration in s.  
**MD**= Mode duration, sample titration time in s.

**Assignment parameters for KFC modes:**

The assignment parameters (Comments, Reagent ... etc.) for the **KFC** modes are the same as those of the **DET** modes, see page 129f.

**8.7.1 Specific parameters for KFC modes [ \* Param ]**

The specific parameters for the respective **KFC** mode can be found under the softkey [ \* Param ].

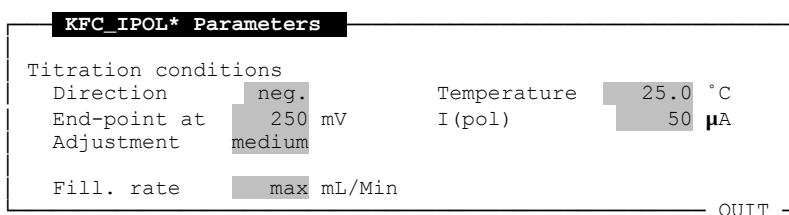

**Titration conditions**

These are the actual titration parameters which control the measurement recording and the dosing behavior during the titration itself.

**Direction**

**Control direction**  
 pos. | **neg.** | auto

The direction of the measurement alterations is important for titration control in the **KFC** mode. Normally the '**neg.**' setting should be used. The '**pos.**' and '**neg.**' settings re-

fer to the numerical measured value alterations. The control direction can also be determined automatically. The control direction is then obtained from the initial measured value and the preset target endpoint.

End-point	Target endpoint
for KFC_IPOL*	-2000... <b>250</b> ...2000 mV
for KFC_UPOL*	-200 ... <b>25</b> ...200 $\mu$ A

The target endpoint defines the measured value which the titration control is aiming for. The standard settings (250 mV or 25  $\mu$ A) are ideal in most cases and should only be altered in exceptional cases. See also page 111ff.

Adjustment	Predefined parameter sets <i>slow</i>   <b>medium</b>   <i>fast</i>
------------	--

A selection can be made from three different sets of parameters for the simplified setting of the titration parameters. Each of these sets includes proven controller settings which are suitable for most requirements.

*slow* for low water content or samples which only release their moisture slowly

*medium* standard parameters for unproblematic titrations, optimized for the commonest applications

*fast* for high water content of non-critical samples

If the titration parameters have to be adapted for specific titration problems the different control parameters can be altered individually.

The [**Custom adjust**] softkey opens a further dialog window in which user-defined settings can be carried out (see page 165).

Fill. rate	Buret filling rate <i>0.01 mL/min</i> ... <i>150 mL/min</i>   <b>max.</b>
------------	--

At the end of a titration the buret is automatically filled. The maximum value for the filling rate depends on the cylinder size of the buret used.

Buret cylinder	max. speed
1 mL	3 mL/min
2 mL	6 mL/min
5 mL	15 mL/min
10 mL	30 mL/min
20 mL	60 mL/min
50 mL	150 mL/min

A value up to 150 mL/min can also be entered for smaller buret cylinders; however, when the method is carried out the dosing speed will automatically be reduced to the largest possible value. For KF reagents (viscous liquids) no filling rate greater than 30 mL/min should be selected as otherwise too rapid filling may cause a partial vacuum in the cylinder (bubble formation!).

---

<b>Temperature</b>	<b>Temperature setting or measuring mode</b> -170... <b>25.0</b> ...500°C   <i>auto</i>   <i>initial</i>
--------------------	---

The temperature can be automatically determined during a titration with the aid of a Pt100/Pt1000 sensor or a combined electrode with built-in temperature sensor. It is possible to record the temperature throughout a titration and to output it as a temperature curve.

<i>numerical</i>	manual input
<i>auto</i>	automatic measurement during the whole titration (for temperature curve)
<i>initial</i>	one-off measurement at the start of the titration mode

The temperature can be included in formulas for calculations (see page 119ff), e.g. for volume corrections. The different system variables are listed on page 149 and 129.

**Please note:** Start temperature **ST** and closing temperature **CT** are only available with *auto*.

---

<b>U(pol)</b>	<b>Polarization voltage</b> (with <b>KFC_UPOL*</b> ) -1270... <b>400</b> ...1270 mV
---------------	--

The polarization voltage is the voltage which is applied to a polarized electrode during amperometric titration. The resultant measuring quantity is  $I_{pol}/\mu A$ .

---

<b>I(pol)</b>	<b>Polarization current</b> (with <b>KFC_IPOL*</b> ) -127... <b>25</b> ...127 $\mu A$
---------------	--

The polarization current is the current which is applied to a polarized electrode during voltametric titration. The resultant measuring quantity is  $U_{pol}/mV$ .

## 8.8 MEAS

Methode: NEW.mth

t/s	Command	Parameters	Parameters
1	MEAS_PH*	Sensor Meas. input A1 Temperature 25.0 °C	Signal drift 50 mV/Min Equilibr.time auto s
2	MEAS_U*	Sensor Meas. input A1 Temperature 25.0 °C	Signal drift 50 mV/Min Equilibr.time auto s
3	MEAS_UPOL*	Sensor Meas. input Apol Temperature 25.0 °C	Signal drift 50 µA/Min Equilibr.time auto s
4	MEAS_IPOL*	Sensor Meas. input Apol Temperature 25.0 °C	Signal drift 50 mV/Min Equilibr.time auto s
5	MEAS_T*	Sensor Meas. input AT	Equilibr.time 1 s

QUIT

It is possible to carry out both a drift-controlled single measurement (standard) and also a series of drift-controlled measurements (multiple) with a single command.

Five different **MEAS** modes are available for measurements; they differ only in the measured quantity:

**MEAS\_PH\*** measured quantity pH  
**MEAS\_U\*** measured quantity mV  
**MEAS\_UPOL\*** measured quantity µA (selectable pol.voltage in mV)  
**MEAS\_IPOL\*** measured quantity mV (selectable pol.current in µA)  
**MEAS\_T\*** measured quantity °C (temperature measurement with Pt100/1000)

The following information applies to all **MEAS** modes. Any variations are noted.

MEAS modes create the following system variables:

**R\$\$** End result / live result  
**X\$\$** Intermediate result / live result (not mentioned in report)  
**C\$\$** Common variables (automatic assignment)  
**IM** Initial measured value at start of mode; depends on measuring quantity  
**SM** Start value, first measured value in MP list  
**CM** Final value at end of measurement, last measured value in MP list  
**IT** Initial temperature at start of mode in °C  
**ST** Start temperature at start of measurement, for first measured value  
**CT** Closing temperature at end of measurement in °C  
**MD** Mode duration (total length of measurement) in s  
**SD** Start duration in s (for preparing the measurement)  
**\$LM** Live measured value (depends on measured quantity)

For **MEAS\_T\*** the measured values are equated with the temperature values.

The measuring parameters

MEAS_PH*	potent. or volta-/amperometric measurement	
Sensor		Signal drift 50 mV/min
Meas. input	A1	Equilibr.time auto s
Temperature	25.0 °C	

applies to ⇒ MEAS\_PH\*, MEAS\_U\*, MEAS\_UPOL\*, MEAS\_IPOL\*  
MEAS\_T\* see below.

The measuring parameters apply to single, drift-controlled measurements.

Comment	Comments on measuring mode (50 characters)
---------	---

The commentary on the mode is used for identifying the specific measurement within a determination. This is chiefly used for more complex methods with several titration or measuring modes.

Signal drift	Limit for measurement drift
--------------	-----------------------------

for MEAS\_PH/U/IPOL: 0.5...50...999 mV/min | off  
for MEAS\_UPOL: 0.1...50...100 µA/min | off

The measured value is only accepted when the variation in the sensor measurement falls below the given value for the measurement drift. If this is delayed then the measurement will nevertheless be accepted when the preset delay period (see below) has elapsed. This measured value drift control can be switched off ('OFF'). If drift control is switched off the preset delay period (see below) will be strictly observed. This can be favorable for multiple measurements with short measuring interval cycles.

Meas. input	Sensor connection sockets (A1,A2, Apol, Adiff, B1, B2, Bpol, Bdiff)
-------------	--

The measuring inputs **A1**, **A2** and **Apol** are located on the rear panel of the instrument in the measuring group **Sensors A**. **Adiff** stands for the measuring amplifier switch on the measurement inputs **A1**, **A2** and **Ref**. If a second measuring group (**Sensors B**) is present then the addresses **B1**, **B2**, **Bpol** and **Bdiff** can be similarly used. Depending on the measuring quantity only sensible sensor addresses can be selected, e.g. for **MEAS\_IPOL\*** only **Apol** or **Bpol**.

---

**Equibr.time** Max. delay period before measurement acceptance  
*0.1...9999 s | auto | off*

The whole delay period for measurement acceptance becomes effective when, with switched-on drift control (see measurement drift above), the preset value for the drift is not undercut. Otherwise the measurement will be accepted when the measurement drift is reached. The whole delay period will also be allowed to elapse if the drift control is switched off.

The equilibrium time can be switched off. In this case only the measurement drift is decisive for the measurement acceptance.

With the setting '**Equibr.time auto**' the Titroprocessor will use an equilibrium time which is suitable for the preset measurement drift value. It is calculated according to the following equation:

$$\text{Equibr. time (in s)} = \frac{150}{\sqrt{\text{drift} / (\text{mV} / \text{min}) + 0.01}} + 5$$

For the standard setting 50 mV this results in an equilibrium time of 26 s.

For multiple measurements the equilibrium time must be shorter than the measuring interval as otherwise the timing pattern for the measuring intervals cannot be followed if the measurement drift is too large.

---

**Temperature** **Temperature setting or measuring mode**  
*-170...25.0...500°C | auto | initial*

The temperature can be automatically determined during a titration with the aid of a Pt100/Pt1000 sensor or a combined electrode with built-in temperature sensor and can be used for automatic pH correction (if pH is being measured).

It is possible to record the temperature throughout a titration and to output it as a temperature curve.

<i>numerical</i>	manual input (e.g. for pH correction)
<i>auto</i>	automatic measurement during the whole titration (for temperature curve)
<i>initial</i>	one-off measurement at the start of the titration mode

The temperature can be included in formulas for calculations (see page 119ff), e.g. for volume corrections. The different system variables are listed on page 172 and 129.

**Please note:** start temperature **ST** and closing temperature **CT** are only available with *auto*.

```
MEAS_T*      Temperature measurement
Sensor      [redacted] Equibr.time 1 s
Meas. input AT
```

applies to ⇒ MEAS\_T\*

No drift control is available in the temperature measuring mode **MEAS\_T**. If necessary, measurement acceptance can be delayed with the equilibrium time in order for the sensor to achieve equilibrium temperature.

The other settings correspond to those of the other **MEAS** modes.

```
Equibr.time  Delay period before measurement acceptance
              0.1...1...9999 s | auto | off
```

For **MEAS\_T** the whole equilibrium time is effective for each measurement acceptance. The measured value is accepted when the equilibrium time has elapsed.

With 'off' and 'auto' the equilibrium time is switched off and the measurement is accepted immediately.

For multiple measurements the equilibrium time must be shorter than the measuring interval as otherwise the timing pattern for the measuring intervals cannot be followed.

### 8.8.1 Standard measurement

A standard measurement is a single measurement in which a single measured value is recorded according to the measurement parameters and then terminated. The measuring procedure (standard measurement / multiple measurement) can be selected under the extended parameters (softkey [**\*Param** ]) together with further data recording parameters.

```
MEAS_PH* Parameters
Data acquisition
Meas. procedure  standard
Sampling time    1 s
QUIT
```

---

**Data acquisition**

Depending on the selected measuring procedure, data acquisition may have different settings.

---

<b>Meas. procedure</b>	<b>Single or multiple measurement</b> <i>standard</i>   <i>multiple</i>
------------------------	--

Switches between standard and multiple measurement.

---

<b>Sampling time</b>	<b>Time interval for raw data acquisition</b> for 'Standard' measuring procedure <i>1...9999 s</i>   <i>off</i>
----------------------	--

The sampling time determines the time pattern for presenting the raw data which are to be taken into account when determining the drift value during a drift-controlled single measurement. It has no influence on the effective measurement. The raw data can be shown as a curve. This can be useful in assessing the setting behavior of a sensor.

---

<b>U(pol)</b>	<b>Polarization voltage</b> (for <b>MEAS_UPOL*</b> ) <i>-1270...400...1270 mV</i>
---------------	--

The polarization voltage is the voltage which is applied to a polarized electrode during amperometric measurement. The resultant measuring quantity is  $I_{pol}/\mu A$ .

---

<b>I(pol)</b>	<b>Polarization current</b> (for <b>MEAS_IPOL*</b> ) <i>-127...1...127 <math>\mu A</math></i>
---------------	--

The polarization current is the current which is applied to a polarized electrode during voltametric measurement. The resultant measuring quantity is  $U_{pol}/mV$ .

---

### 8.8.2 Multiple measurement

---

A multiple measurement is a series of (drift-controlled) single measurements, each of which is made in a particular time pattern according to the set measuring parameters and produces a single measured value. Multiple measurements can be used to record alterations of certain measuring quantities such as pH or temperature over a longer period of time and show them as a curve. This ensures that each individual measurement, thanks to the drift-controlled measurement acceptance, is always a reliable one. Up to 1000 measured values can be recorded in this way.

The measuring procedure (standard measurement / multiple measurement) can be selected under the extended parameters (softkey [**\*Param**]) together with further data recording parameters.

```

MEAS_PH* Parameters
Data acquisition
Meas. procedure      multiple
Measuring interval  off s           Start val. pH  off
Meas. cycles        1           Stop val. pH  off
QUIT
    
```

**Data acquisition**

Depending on the selected measuring procedure, data acquisition may have different settings.

**Meas. procedure**                      **Single or multiple measurement**  
*standard | multiple*  
 Switches between standard and multiple measurement.

**Meas. interval**                      **Time interval between single measurements**  
*0.1...9999 s | off*  
 The measuring interval is the time pattern at which a single measurement is triggered within the series. If a drift-controlled measurement is recorded then this is not accepted in the measuring point list immediately, but only at the time at which the measure acceptance conditions (drift) have been fulfilled. This can lead to an irregular time pattern in the measuring point list. If **off** is selected the single measurements will be made at the shortest possible time interval (<50 ms).

**Meas. cycles**                      **Number of single measurements in a series**  
*1...1000 | inf. | max*  
 The maximum number of single measurements is 1000. With **'inf.'** the measuring series will not end, but after 1000 measuring points have been recorded no further values will be entered in the measuring point list. With **'max'** the series is stopped after 1000 measuring points.

**Start val.**                      **Measured value at the start of the series**  
 for MEAS\_PH\*                      *pH -20...20 | off*  
 for MEAS\_U\*, MEAS\_IPOL\*        *-2000...2000 mV | off*  
 for MEAS\_UPOL\*                    *-200 ...200 µA | off*  
 for MEAS\_T\*                      *-170...500°C | off*  
 If a start value is set this means that the measuring series will only be started when the defined value is exceeded in the sample solution. The direction in which the measurements alter is irrelevant.

Stop val.	Measured value for terminating the meas. series
	for MEAS_PH* <i>pH</i> -20...20   <b>off</b>
	for MEAS_U*, MEAS_IPOL* -2000...2000 mV   <b>off</b>
	for MEAS_UPOL* -200 ...200 $\mu$ A   <b>off</b>
	for MEAS_T* -170...500°C   <b>off</b>

If a stop value is set this means that the measuring series will be prematurely terminated as soon as the defined measuring value is exceeded. The direction in which the measurements alter is irrelevant.

### 8.8.3 Curve display in MEAS modes

The possible settings for curve display in the **MEAS** modes correspond to those of the **DET** modes with the exception of the representation on the volume axis and the derived curves.

Quantity Y-Axis	Measuring quantities on the Y-axis
	<i>M. value</i>   <i>Temp.</i>   <i>MV,Temp</i>   <i>all</i>

As well as the standard representation of measured value/volume other representations are possible. Selection of measuring quantities on the Y-axis:

<i>M. value</i>	pH, mV, $\mu$ A or °C (depends on mode)
<i>Temp.</i>	only for automatic measurements
<i>MV, Temp</i>	measured value and temp. combined
<i>all</i>	all representable curves, combined

## 8.9 CAL

Automated calibration of pH electrodes is possible as well as manual calibration. Individual buffer sets can be defined and stored in a method. The calibration can be carried out as a simple run in dialog operation with manual change of the buffer solutions. If a sample changer is used the calibration procedure can be carried out fully automatically. The necessary sample changer commands can be programmed in detail in a calibration loop.

The **CAL\*** mode creates the following system variables:

<b>R\$\$</b>	End result
<b>X\$\$</b>	Intermediate result (not shown in report)
<b>C\$\$</b>	Common variables (automatic assignment)
<b>AP</b>	Asymmetry pH value, pH(as)
<b>SL</b>	Slope of the calibrated electrode
<b>IM</b>	Initial measured value at start of calibration (in mV)
<b>CM</b>	Closing measured value at end of calibration (in mV)
<b>IT</b>	Initial temperature at start of calibration in °C
<b>CT</b>	Closing temperature at end of calibration in °C
<b>MD</b>	Mode duration (total measurement period) in s

No live displays are possible in the calibration mode. However, it is possible to carry out calculations using existing system variables, see page 119ff.

The calibration data produced are entered on the Devices & Manual Control' page. The corresponding calibration curve is also available.

### 8.9.1 Simple calibration

#### Calibration parameters

CAL\*

Calibration			
Sensor		Signal drift	2 mV/min
Meas. input	A1	Equilibr.time	auto s
Temperature	25.0 °C		

**Comment** **Comments on calibration mode**  
(50 characters)

The commentary on the mode is used for identifying the specific measurement within a determination. This is chiefly used for more complex methods with several titration or measuring modes.

**Signal drift** **Limit for measurement drift**  
0.5...2...999 mV/Min | off

The measured value is only accepted when the variation in the sensor measurement falls below the given value for the measurement drift. If this is delayed then the measurement will nevertheless be accepted when the preset delay period (see below) has elapsed.

This measured value drift control can be switched off ('**off**'). However, this is not recommended for correct calibration.

---

<b>Meas. input</b>	<b>Sensor connection sockets</b> ( <b>A1</b> , <b>A2</b> , <b>Adiff</b> , <b>B1</b> , <b>B2</b> , <b>Bdiff</b> )
--------------------	---

The measuring inputs **A1**, **A2** and **Apol** are located on the rear panel of the instrument in the measuring group **Sensors A**. **Adiff** stands for the measuring amplifier switch on the measurement inputs **A1**, **A2** and **Ref**. If a second measuring group (**Sensors B**) is present then the addresses **B1**, **B2**, **Bpol** and **Bdiff** can be similarly used.

---

<b>Equilibr.time</b>	<b>Max. delay period before measurement acceptance</b> 0.1...9999 s   <b>auto</b>   off
----------------------	--

The whole delay period for measurement acceptance becomes effective when, with switched-on drift control (see measurement drift above), the preset value for the drift is not undercut. Otherwise the measurement will be accepted when measurement drift is reached.

The whole delay period will also be allowed to elapse if the drift control is switched off.

The equilibrium time can be switched off. In this case only the measurement drift is decisive for the measurement acceptance.

With the setting '**Equilibr.time auto**' the Titroprocessor will use an equilibrium time which is suitable for the preset measurement drift value. It is calculated according to the following equation:

$$\text{Equilibr.time (in s)} = \frac{150}{\sqrt{\text{drift} / (\text{mV} / \text{min}) + 0.01}} + 5$$

For the standard setting 2 mV this results in an equilibrium time of 110 s.

---

<b>Temperature</b>	<b>Temperature setting or measuring mode</b> -170... <b>25.0</b> ...500°C   <b>auto</b>   off
--------------------	--

The temperature can be automatically determined during a measurement with the aid of a Pt100/Pt1000 sensor or a combined electrode with built-in temperature sensor. It is required for automatic pH correction.

<i>numerical</i>	manual input
<i>auto</i>	automatic measurement during calibration
<i>off</i>	no temperature correction

The temperature can be included in formulas for calculations (see page 119ff). The different system variables are listed on page 179 and 129.

### 8.9.2 Specific CAL\* mode parameters [ \* Param ]

The buffer tables for the relevant CAL\* mode can be found under the [ \* Param ] softkey.

CAL* Parameters		
Buffer	Type	Value [pH]
1	Metrohm	7.000
2	Metrohm	4.000
3	Metrohm	
4	Metrohm	
5	Metrohm	
6	Metrohm	
7	Metrohm	
8	Metrohm	
9	Metrohm	

QUIT

Up to nine different buffer solutions of various types or manufacturers can be entered here.

#### Type

#### Buffer solution type or manufacturer

*Metrohm | NIST | DIN | Fisher | Novartis | Ingold | Merck | Beckman | Radiom. | none | custom*

As the buffer solutions can have very different compositions, it is necessary to enter the correct buffer type so that the temperature correction function can be correctly applied during the calibration.

If your type of buffer is not given in the list you should select '**none**'.

During the calibration the determined values are compared with the buffer solution information (theoretical value, temperature for automatic temperature measurements) and subjected to a plausibility test, see page 118. If this leads to interfering error messages with '*exotic*' buffers or '*extraordinary*' sensors, then select the buffer type '**custom**' for user-defined buffer types. No plausibility test is carried out in this setting.

#### Value [pH]

#### Nominal pH of the buffer *pH -20...20*

The buffer solutions offered by the above-mentioned manufacturers are stored in the Titroprocessor with their nominal values. The entry field has a selection list in which various buffer values depending on the given buffer type or manufacturer can be selected. It is also

possible to enter other values.  
If no buffer value is entered the Titroprocessor will try to determine the appropriate value during the method run and use it in the calibration.

### Calibration procedure

The buffer solutions entered as a parameter will be processed in the sequence given. Before an individual buffer is measured an information window opens to show which buffer should be measured. This ensures that the correct buffer is used for the measurement.

```

Message
Hold:
Prepare buffer 7.000!
           press  <HOLD/CONT>
QUIT

```

### 8.9.3 Automatic calibration

If an automatic calibration is to be carried out using a sample changer then it is necessary to carry out sample changer commands between the measurements of the individual buffer solutions. This can be achieved by programming a calibration loop (**CAL...**)**CAL**.

Command	Parameters	Parameters
...		
...		
(CAL		
...		
...		
CAL*	Calibration with defined buffer table	
	Sensor comb. glass	Signal drift 2 mV/min
	Meas. input Al	Equilibr.time auto s
	Temperature 25.0 °C	
...		
...		
)CAL		
...		
...		

When a calibration loop is processed a particular buffer solution in the defined buffer table will be measured. The calibration loop is run through several times until all buffer solutions have been measured, when the method processing will be continued with the next command.

Calibration loop processing is controlled by the system variable **\$BC** (**Buffer Counter**). This counter can be accessed during a method run (e.g. in a **CASE** sequence, see page 195ff).

In an automatic calibration the buffer solutions should be placed in the special beaker positions (see page 42) of a sample rack.

The simplest form of an automatic calibration loop could look like this:

Command	Parameters	Parameters
(CAL		
(CASE	\$BC = 1	
MOVE_B	Special beaker Buffer 7	to Tower 1
CASE	\$BC = 2	
MOVE_B	Special beaker Buffer 4	to Tower 1
)CASE		
LIFT	on Tower	1 to position work mm
STIR C	Address	1 Stirring rate 6
CAL*	pH Sensor calibration	
	Sensor comb. glass	Signal drift 2 mV/min
	Meas. input Al	Equilibr.time auto s
	Temperature 25.0 °C	
STIR_C	Address	1 Stirring rate off
LIFT	on Tower	1 to position shift mm
...		
)CAL		

The precondition for this type of automatic calibration is that the special beaker positions (with the corresponding names) of the sample rack used have been correctly configured.

On the flash card supplied with the 796 Titroprocessor you will find a method (**SC\_CAL.mth**) in which the automatic calibration is completely programmed as the start sequence for a series of titrations. You only need to complete it with a titration mode and to enter the buffers to be used (in **CAL\*** mode). Do not forget to define the required special beakers for the sample rack to be used.

### Behavior if calibration problems occur

If during an automatic calibration a calibration error occurs and the run is not interrupted the following automatic procedures are provided:

- If a buffer cannot be properly measured then this buffer will not be taken into account for the calibration. The calibration will nevertheless be continued. A corresponding error message will appear in the result report.
- If at least two buffers can be properly measured then these values will be used for the calibration. The method will be continued.
- If only one buffer or no buffer at all can be properly measured the calibration will be interrupted with an error message. You must then decide whether the method should nevertheless be continued or terminated. In the first case standard calibration data (pH<sub>as</sub> 7.000, slope 1.000) will be assumed.

## 8.10 Sample changer commands

```

Titration >
Changer >
CAL
MEAS_*
DOS
STIR_I
CASE
COMM
AUX
CHANGER
SAMPLE
MOVE_S
MOVE_B
LIFT
PUMP
STIR_C
RESET_C
(OMOVE)
)OMOVE
(CMOVE)
)CMOVE
    
```

The versatile commands for controlling one (or two) 717 Sample changer(s) allow the comprehensive automation of even complex working procedures. With the sequences **(OMOVE...)**OMOVE and **(CMOVE...)**CMOVE sample series can be processed in a very individual manner. Conditional processes can be realized with **(CASE...EXIT...)**CASE structures.

The standard methods supplied on the flash card (SCsimple.mth) for sample changer control can be easily altered and adapted to meet different requirements.

Stored sample changer methods can usually be easily transferred to other 796 Titroprocessors. However, care must be taken that the rack definitions (including working and rotating lift positions, positions and names of the special beakers, etc.) of the corresponding sample changer are carried out correctly.

### 8.10.1 Sample changer commands

#### CHANGER

#### Basic sample changer settings

The **CHANGER** command sets the active (of two possible) 717 Sample changer and defines its basic settings. The command can be programmed at any point of the run so that it is possible to operate two different sample changers within a single method. The EBus address selector disk on the appropriate sample changer must be set correctly: for the first changer to **1**, for the second changer to **2**, see sample changer installation on page 25.

Command	Parameters	Parameters
<b>CHANGER</b>	Selection 1	Rack name
	Lift rate 1 25	Lift rate 2 25
	Shift rate 20	Beaker test mode single
	Shift direction auto	On beaker error MOVE_S

#### Selection

#### Address of the active sample changer 1 / 2

The changer address defines which changer is active and for which sample changer the following basic settings will apply.

#### Rack name

#### Name of the required rack 8 characters

This entry is optional. If a rack name has been entered then the use of the described rack will be forced, i.e.

when processing the **CHANGER** command the sample changer will be initialized again, the rack code of the sample rack used will be read and compared with the configuration data (and thus the rack name) in the rack tables.

**Lift rate 1 / 2**
**Lift speed at tower 1 and 2**

 3...**25** mm/s

If a lift head is heavily loaded with titration accessories, several sensors, etc. then the lift speed should be reduced. It is possible to set different speeds for the two lift towers.

**Shift rate**
**Rotational speed of the turntable**

 3...**20** %/s

The rotational speed of the sample changer turntable can be varied according to the load.

**Beaker test mode**
**Test mode of the beaker sensor**
*single* / *both*

After each **MOVE** command of the sample changer the beaker sensor of the changer tower checks whether a beaker is present in the rack position which has been moved to.

For racks whose arrangement of beaker positions does not correspond with the setting angle of both the changer towers (e.g. 14-place, 16-place racks) the test mode '**single**' should be switched on. In this way only the beaker sensor of the approached tower is activated. If parallel processing is carried out at two towers then, provided a suitable rack is used, the test mode '**both**' can be selected.

**Shift direction**
**Rotational direction of the sample rack**
*auto* / + / -

There are different settings for the rotational direction of the sample rack:

<i>auto</i>	the changer always selects the shortest rotational path
+	counterclockwise direction, towards higher rack positions
-	clockwise, towards lower rack positions

Take care that samples which have not been processed are not contaminated by dripping sensors or similar.

**On beaker error****Behavior with missing sample beaker***MOVE\_S* | *display*

If a beaker sensor finds that a sample beaker is missing then this instruction can be used to carry out two subsequent actions automatically:

<i>display</i>	An error message is displayed and the operator must take action. The instrument moves to the <b>'hold'</b> condition and the changer can be operated manually.
<i>MOVE_S</i>	The previous <b>MOVE</b> command is carried out again; the changer "looks for" the next sample beaker. A previous <b>SAMPLE</b> command will be taken into account, i.e. with <b>'SAMPLE +2'</b> the next but one sample beaker will be moved to.

**SAMPLE****Alteration of the run variable SAMPLE**

The run variable SAMPLE is used as a sample counter during the processing of a series of samples. It always refers to the current sample position in the sample rack. It can be set manually with the **'Sample pos.'** entry on the Titroprocessor main page. However, a **SAMPLE** command will overwrite this entry. When a sample has been processed the run variable will be automatically increased by **1** so that in a method the next sample beaker can always be brought into position with the command **MOVE\_S**.

This run variable, and therefore the particular valid sample position, can be specifically altered with this **SAMPLE** command. If the **SAMPLE** command is used in a method then the automatic **SAMPLE** variable increase is switched off.

Command	Parameters	Parameters
<b>SAMPLE</b>	Function	+ Value

**Function****Type of SAMPLE variable alteration**

+ | - | =

The SAMPLE variable can be increased ('+') or decreased ('-'). Allocation of a specific value ('=') (setting a particular sample position) only makes sense in an (**OMOVE**) start sequence.

**Value** **Numerical value of alteration or allocation**  
0...1...999

The numerical value of how much the **SAMPLE** variable has been altered or what value it should be allocated can be freely selected (whole numbers).

---

**MOVE\_S** **Position current sample beaker**

The command **MOVE\_S** can be used to position the current sample beaker in front of tower 1 or 2 of the sample changer.

The rack is rotated so that the beaker position of the rack, which corresponds to the contents of the **SAMPLE** variable (see above) comes to rest in front of the tower given in the command. Rotation of the rack is only possible when the lift (or both lifts) are located on or above its rotation position (see **LIFT** command below).

After the racks has been rotated the corresponding beaker sensor checks whether a beaker is present in this position. If this is not the case then the procedure defined in the beaker test mode (see page 185) will be carried out.

Command	Parameters	Parameters
<b>MOVE_S</b>	Sample to Tower	1

**Sample to tower** **Rack rotation target**  
1 / 2

With a 2-tower changer the target of the rack rotation and thus the positioning of the current sample beaker can be selected at will. In this way it is possible to subject the same sample to different processing steps at two work stations during a method run. For example, these could be two different titrations or more complicated sample preparation steps.

---

**MOVE\_B** **Positioning special beaker**

Up to eight special beakers (rinsing, conditioning beakers, etc.) with permanently assigned rack positions can be defined for a single sample rack. The command **MOVE\_B** can be used in a method run to position a special beaker in front of either of the changer towers.

Rotation of the rack is only possible when the lift (or both lifts) are located on or above its rotation position (see **LIFT** command below).

Command	Parameters	Parameters
<b>MOVE_B</b>	Special beaker	to tower 1

**Special beaker****Name of special beaker**

8 characters

The special beaker can be specified by its name. The entry field contains a selection list in which first the rack and then the required special beaker can be selected.

**to tower****Rack rotation target**

1 / 2

The tower in front of which the special beaker is to be positioned can be freely selected.

**LIFT****Positioning lift**

The lift with the titration head can be positioned to the nearest millimeter. It is recommended that predefined lift positions are used and fixed in the configuration for the specific rack.

Command	Parameters	Parameters
<b>LIFT</b>	to tower	1 to position 0 mm

**on tower****Address of the lift**

1 / 2

In a 2-tower changer the lifts can be selected at will. The lift address always refer to the active changer.

**to position****Target position of the lift**

work | shift. | rinse. | rest | spec | 0...325 mm

The user-defined lift positions (work position, shift position, rinsing position, special position) can be defined at will for each rack, depending on the beaker sizes used.

<i>work position</i>	lift position in which e.g. a titration can be carried out
<i>shift position</i>	lift position in which the rack can be freely rotated without damaging the sensors or other items.
<i>rinsing position</i>	lift position for rinsing the titration head
<i>rest position</i>	start position at the upper end of the tower (0 mm)
<i>special position</i>	freely selectable lift position

**PUMP** **Pump control**

Different pumps can be controlled depending on the sample changer version. A rinsing and a aspiration pump can be installed on one changer tower. These can be switched separately. The duration of rinsing and suction processes can be comfortably controlled with the line time of the **PUMP** command.

External pumps, e.g. for removing titration solutions containing solids, can be controlled via remote output leads (remote socket, see **CTRL** command).

Command	Parameters	Parameters
<b>PUMP</b>	Address	State

**Address** **Pump address**  
*1.rinse | 1.aspir | 2.rinse | 2.aspir*

The address of a pump consists of the specification of the changer tower (1 or 2) and the function of the pump (rinsing=pump 1, aspirate=pump 2). It is valid for the currently active changer.

**State** **Pump status**  
*on | off*

A pump can only be switched on or off. The pumping duration can be controlled with the line time of the PUMP command. Example:

t/s	Command	...	Parameters
5	PUMP	...	State on
	PUMP	...	State off

**STIR\_C** **Sample changer stirrer control**

In contrast to the stirrer connections of the Titroprocessor itself, the stirrer speed can be controlled on the 717 Sample changer.

Command	Parameters	Parameters
<b>STIR_C</b>	Address	Stirring rate

**Address** **Stirrer address**  
*1...4*

The stirrer address always refers to the active changer. With 1-tower changer models only 2 stirrers (722 Rod stirrer or 741 Magnetic stirrer) can be connected.

**Stirring rate**

**Stirrer speed**  
1...15 | off

The stirring speed of each individual stirrer can be varied in 15 steps.

**RESET\_C**

**Initializing changer**

After sample racks have been changed it is necessary to initialize the sample changer. This is done by rotating the sample turntable to the basic position and reading off the magnetic code for identification of the rack. This is normally carried out manually, but can also be programmed in a method (preferably in the start sequence, see **OMOVE** below).

Command	Parameters	Parameters
<b>RESET_C</b>	Selection	1

**Selection**

**Changer address**  
1 | 2

Changer 1 or changer 2 are defined by the setting of the EBus address selector disk on the sample changer, see page 25.

**(OMOVE  
)OMOVE**

**Start sequence for a series of samples**

When a series of samples is being processed it is often necessary to carry out certain working steps a single time before the sample series itself. For example, these could be rinsing procedures or conditioning steps for sensors.

The definition of the necessary command sequence is made in an **OMOVE** sequence (**OMOVE** = Opening Moves), which is enclosed by the starting marker **(OMOVE** and the end marker **)OMOVE**.

**Example: Rinsing a sensor:**

t/s	Command	Parameters	Parameters
	<b>(OMOVE</b>		
	CHANGER	Selection 1	Rack name
		Lift rate 1 25	Lift rate 2 25
		Shift rate 20	Beaker test mode single
		Shift direction auto	On beaker error MOVE_S
	MOVE_B	Special beaker waste	to tower 1
	LIFT	on tower 1	to position rinse mm
10	PUMP	Address 1.rinse	State on
	PUMP	Address 1.aspir	State on
	PUMP	Address 1.rinse	State off
	PUMP	Address 1.aspir	State off
	LIFT	on tower 1	to position shift mm
	)OMOVE		
	...		

During the first run of the method the commands in the **(OMOVE...)** sequence are carried out at the start of the sample series. These are ignored each time the method is subsequently carried out. As all commands are carried out logically in their programmed sequence it is highly recommended that the start sequence is programmed in the first command lines of a method.

---

**( CMOVE Closing sequence of a sample series ) CMOVE**

When processing a series of samples it may be advantageous to carry out particular working steps a single time after the sample series itself. For example, these could be rinsing procedures or sensor regeneration.

The definition of the necessary command sequence is made in a **CMOVE** sequence (**CMOVE** = Closing Moves), which is enclosed by the starting marker **(CMOVE** and the end marker **)CMOVE**.

**Example:** Sensor immersion in a conditioning solution:

t/s	Command	Parameters	Parameters
...	...	...	...
	<b>( CMOVE</b>		
	LIFT	on tower	1 to position shift mm
	MOVE B	Special beaker	3m KCl 1 to tower 1
	LIFT	on tower	1 to position work mm
	<b>) CMOVE</b>		
	END		

The commands in the **(CMOVE...)** sequence are carried out during the last method run at the end of the sample series. These are ignored when the preceding samples are processed. As all commands are carried out logically in their programmed sequence it is highly recommended that the start sequence is programmed in the last command lines of a method.

## 8.11 Dosing commands

The dosing commands allow various auxiliary reagents to be added from different dosing devices during complex method runs.

---

### **ADD\_A** **Adding an absolute volume**

The **ADD\_A** command allows a preset volume of an auxiliary reagent to be added at any time during a method run.

Command	Parameters	Parameters
<b>ADD_A</b>	Reagent Concentr. Volume	Dos. drive A1 Dos. rate max mL/min Fill. rate max mL/min

### **Reagent** **Reagent name** *13 characters*

If a name is entered here the automatic reagent check can be used.

At the start of the method a check is made as to whether a different entry for the current occupancy of the addressed dosing device has been given under '**Devices & Manual Control**' (<MAN CONTROL> key). If these do not coincide an error message is displayed.

No entry in the '**Reagent**' field (or on the '**Devices & ...**' page) prevents an automatic reagent check.

---

### **Dos. drive** **Dosing device address** *(A1...A4, B1...B4, C1...C4)*

The connection sockets **Dos. A1...Dos. A4** on the rear panel of the instrument have the addresses **A1...A4**. Further dosing devices connected to the '**External Bus**' with the help of a Dosimat interface 729 receive the addresses **B1...B4** (Dosimat interface 1, EBus address 1) or **C1...C4** (Dosimat interface 2, EBus address 2).

---

### **Concentr.** **Concentration of auxiliary reagent** *(numerical | 5 characters)*

Two fields for the input of the concentration of the reagent solution and concentration units. These fields are also used for reagent checking (see above) and are compared with the entries in the dialog window '**Devices & Manual Control**' at the start of a method.

**Dos. rate** **Addition speed**  
0.01 mL/min...150 mL/min | **max.**

The maximum dosing speed depends on the cylinder size of the buret used.

<i>Buret cylinder</i>	<i>max. speed</i>
1 mL	3 mL/min
2 mL	6 mL/min
5 mL	15 mL/min
10 mL	30 mL/min
20 mL	60 mL/min
50 mL	150 mL/min

A value up to 150 mL/min can also be entered for smaller buret cylinders; however, when the method is carried out the dosing speed will automatically be reduced to the largest possible value. Whenever possible '**max**' should be selected, except for viscous reagent solutions.

**Volume** **Absolute volume**  
0...999.99 mL

When entering the absolute reagent volume please take the capacity of the target vessel into account.

**Fill. rate** **Buret filling speed**  
0.01 mL/min...150 mL/min | **max.**

The filling rate set here applies to both a concluding automatic filling after a titration and possible refilling during a titration. The maximum value for the filling rate depends on the cylinder size of the buret used.

<i>Buret cylinder</i>	<i>max. speed</i>
1 mL	3 mL/min
2 mL	6 mL/min
5 mL	15 mL/min
10 mL	30 mL/min
20 mL	60 mL/min
50 mL	150 mL/min

A value up to 150 mL/min can also be entered for smaller buret cylinders; however, when the method is carried out the dosing speed will automatically be reduced to the largest possible value. Whenever possible '**max**' should be selected, except for viscous reagent solutions for which too rapid filling can cause a partial vacuum in the cylinder (bubble formation!).

---

**ADD\_R** **Adding a relative volume**

The **ADD\_R** command allows a calculated volume of auxiliary reagent to be added at any time during a method run. The volume is calculated from the sample weight with the aid of a factor.

Command	Parameters	Parameters
<b>ADD_R</b>	Reagent concentr. <input type="text"/> Factor 0.0	Dos. drive <input type="text" value="A1"/> Dos. rate <input type="text" value="max"/> mL/min Fill. rate <input type="text" value="max"/> mL/min

The parameters of the **ADD\_R** command largely correspond to those of the **ADD\_A** command. Only a calculation factor is entered instead of the absolute volume.

**Factor** **Calculation factor**  
-99999.0...0.0...99999.0

The effective value of the relative reagent volume is calculated from:

$$\text{Volume in mL} = \text{Sample size} * \text{factor.}$$

The maximum reagent volume which can be added is 1000 mL. If a larger value is obtained from the calculation then the reagent volume will be automatically reduced to 1000 mL.

The other parameters correspond to those of the **ADD\_A** command, see page 192.

---

**PREP** **Preparing a buret unit**

The preparation, i.e. the rinsing of a buret unit cannot only be carried out manually, but can also be programmed in a method, preferably in a start sequence (**OMOVE**) which is carried out once. The necessary rinsing volume is calculated from the dimensions of the dosing and filling tubing of the exchange unit or dosing unit used.

Command	Parameters	Parameters
<b>PREP</b>	Tubing <input type="text" value="Default"/>	Dos. drive <input type="text" value="A1"/>

**Tubing** **Name of type of buret unit**  
8 characters

The type of buret unit defines the tubing parameters and other settings which are necessary for the correct preparation of the buret unit. The definition of the various types is carried out in the configuration under '**Tubings**'. The entry field contains a selection list with the different types of dosing drive.

**Dos. drive**

**Dosing drive address**  
(A1...A4, B1...B4, C1...C4)

The connection sockets **Dos. A1...Dos. A4** on the rear panel of the instrument have the addresses **A1...A4**. Further dosing drives connected to the '**External Bus**' with the help of a Dosimat interface 729 receive the addresses **B1...B4** (Dosimat interface 1, EBus address 1) or **C1...C4** (Dosimat interface 2, EBus address 2).

**EMPTY**

**Emptying a buret unit** (only for 700 Dosino)

Completely emptying a buret unit cannot only be carried out manually; it can also be programmed in a method. The necessary rinsing volume is calculated from the dimensions of the dosing and filling tubing of the dosing unit.

Command	Parameters	Parameters
<b>EMPTY</b>	Tubing	Default Dos. drive A1

**Tubing**

**Name of the type of buret unit**  
*8 characters*

The type of buret unit defines the tubing parameters and other settings necessary for completely emptying the buret unit. The definition of the various types is carried out in the configuration under '**Tubings**'. The entry field contains a selection list with the defined types.

**Dos. drive**

**Dosing drive address**  
(A1...A4, B1...B4, C1...C4)

The connection sockets **Dos. A1...Dos. A4** on the rear panel of the instrument have the addresses **A1...A4**. Further dosing drives connected to the '**External Bus**' with the help of a Dosimat interface 729 receive the addresses **B1...B4** (Dosimat interface 1, EBus address 1) or **C1...C4** (Dosimat interface 2, EBus address 2).

## 8.12 CASE sequences

Case commands are available for putting together decision structures within a method. With the aid of **CASE** sequences different command blocks depending on defined conditions can be programmed; these are only carried out when the previous condition has been fulfilled. These **CASE** sequences are introduced with **(CASE** and a condition as parameter. They are closed with **)CASE**. Between these additional **CASE** commands with further conditions can be programmed. The individual **CASE** commands always follow the command lines to be processed.

Command	Parameters	Parameters
(CASE	Condition	
...	...	
CASE	Condition	
...	...	
EXIT	Condition	
...	...	
CASE	Condition	
...	...	
)CASE		

A **CASE** sequence is processed so that all **CASE** conditions are individually checked step by step in sequence. As soon as one of the conditions is applicable all the sequence of commands following this CASE command will be carried out up to the next **CASE** command. After this has been processed the CASE sequence will be exited without checking the other conditions.

A conditional premature exit from the CASE sequence can be forced with the **EXIT** command, for which an analogous condition may also be given.

The command process will be continued with the first command line after the **)CASE** end marker.

If none of the conditions apply the CASE sequence will be exited without any further commands being carried out and the method run continued with the next command.

Simple example

Command	Parameters	Parameters
MEAS_PH*	pH measurement	
	Sensor comb. glass	Signal drift 50 mV/min
	Meas. input A1	Equilibr.time auto s
	Temperature auto °C	
(CASE	CM<=7	
DET_PH*	Titration with NaOH	
	Reagent NaOH	Sensor comb. glass
	Concentr. 0.1 mol/L	Meas. input A1
	Dos. drive A1	
CASE	CM>7	
DET_PH*	Titration with HCl	
	Reagent HCl	Sensor comb. glass
	Concentr. 0.1 Mol/L	Meas. input A1
	Dos. drive A2	
)CASE		
END		

The previously measured pH value is evaluated here

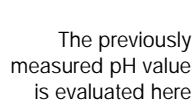

In this case the sample is titrated with different reagents depending on the pH of the sample.

It is possible to interlace CASE sequences in up to 3 levels.

Command	Parameters	Parameters
(CASE	condition 1. level	
...	... commands	
CASE	condition 1. level	
...	... commands	
(CASE	condition 2. level	
...	... commands 2. level	
)CASE		
...	... commands	
CASE	condition 1. level	
...	... commands	
)CASE		

---

**CASE** **Conditional execution of a command block**

The **CASE** command defines the condition within a (**CASE . . .**)**CASE** sequence which determines whether the following command block (up to the next **CASE** command) will be executed.

**Parameters** **Expression for defining the condition**  
*30 characters*

The condition is always defined as an expression formed from the system variable, numerical values and operators (see below). Different expressions can be linked with the logical operators **AND** and **OR**.

---

**EXIT** **Conditional termination of a CASE sequence**

The **EXIT** command within a (**CASE . . .**)**CASE** sequence defines the condition for direct termination of the execution of the **CASE** sequence.

**Parameters** **Expression for defining the condition**  
*30 characters*

The condition is always defined as an expression formed from the system variable, numerical values and operators (see below). Different expressions can be linked with the logical operators **AND** and **OR**.

### System variables

All system variables (see page 121f) can be used. Please note that the current contents of the variables is always decisive.

The sample identifications **ID1**, **ID2** and **ID3** can only be used when they contain numerical values.

Flag variables, such as the endpoint flags **EF1...9** are set as 0 or 1, i.e. EF2=1 means that equivalence point 2 has been found.

### Operators

The following operators are possible:

=	equal to
>	greater than
<	smaller than
>=	equal to or greater than
<=	equal to or smaller than
<>	unequal to
<b>AND</b>	all conditions are met
<b>OR</b>	at least one condition is met

Examples:

**CASE R1>98** (result R1 must be larger than 98)  
**CASE CM>=200** (last value must be greater than/equal to 200)  
**CASE EF1=1** (endpoint flag 1 must be set, EP found)  
**CASE SS<>0** (weight must not be zero)  
**CASE SS>50 AND SS<100** (weight between 50 and 100)  
**CASE R1<90 OR EF1=0** (result smaller than 90 or no endpoint)

**CASE with input lines**

For more complex automation systems the status of the input lines of the remote connection can be set as the condition for a CASE command.

Example:

**(CASE StateA=00000000**  

The condition of this expression has been met when all input lines (**Input 0 ... 7**) of the remote connection on the rear panel of the Titroprocessor are inactive.

The possible status of each line can be queried as follows:

**0** line is inactive ("high" level)  
**1** line is active ("low" level)  
**\*** line status as required

The addresses of the remote connection sockets are:

**StateA** remote socket of the Titroprocessor  
**State1** " of 1st sample changer (717)  
**State2** " of 2nd sample changer (717)

The operators:

**=** equal conditions  
**<>** unequal conditions

Example: **(CASE State1=\*\*\*\*\*1**

*This means that the CASE sequence will be carried out if input line 0 of the 1st sample changer is active. No other input lines will be queried.*

Example of a method with interlaced CASE:

In this case a simple check of the sample weight is made before the titration itself and the result assessed after the titration.

Command	Parameters	Parameters
ASK	Ident. item all	Size confirm.
(CASE	SS>1.0	
WAIT	Sample size too large	
CASE	SS>=0.5	
SHOW	Page Curve	
DET_PH*	Assay	
	Reagent	Sensor
	Concentr.	Meas. input A1
	Dos. drive A1	
(CASE	R1<90 OR EF1=0	
WAIT	Result too low or no EP	
WAIT	Repeat the determination!	
)CASE		
SHOW	Page Main	
CASE	SS<0.5	
WAIT	Sample size too small	
)CASE		
END		

Example of a method remote interface query

In this case an input signal on input line 0 is waited for before a titration is started. If a further input line receives an active signal then an error state will be assumed and the determination terminated without a titration.

Command	Parameters	Parameters
SCAN_RM	Remote A	Pattern *****1
(CASE	StateA<>0000000*	
WAIT	An error occurred!	
CASE	StateA=00000001	
DET_PH*	Sample titration	
	Reagent	Sensor
	Concentr.	Meas. input A1
	Dos. drive A1	
)CASE		
END		

## 8.13 Communication functions

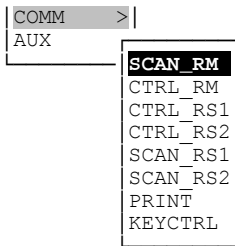

Complex applications require the optimal cooperation between various instruments and components. For this reason the 796 Titroprocessor is provided with special commands. These commands allow synchronization and data communication between instruments which have a parallel remote connection or a serial RS 232 interface.

The two commands **CTRL** and **SCAN** are important for the cooperation of the 796 Titroprocessor with other instruments. They can also be used in combination with instruments from other manufacturers provided that the interface specifications of these are known.

### 8.13.1 Application mode of operation of CTRL and SCAN

The **CTRL** command sends the preset data without delay via the selected RS 232 interface to a connected instrument or sets the predefined conditions of the output lines (**Output 0...7** or **...13**) of the selected remote connection.

The **SCAN** command stops the method run and checks (scans) the incoming data at one of the two RS 232 interfaces or the conditions/signals of the input lines (**Input 0...7**) of a remote connection. The method run will be continued as soon as the defined data have been received or the incoming signals correspond to those set down.

### 8.13.2 Remote connections

Most Metrohm instruments have a remote connection (D-sub, 25-pins), which is provided for external control of the instrument. By setting particular input lines various functions (start, stop etc.) can be triggered or different measuring modes activated. At the same time the instrument signalizes its instrument status or status change or certain events by activating its various output lines.

The remote functions most often required for Metrohm instruments:

Function	Line	Status
<b>Start</b>	Input 0	active
<b>Stop</b>	Input 1	active

The status signals most often required for Metrohm instruments:

Signal	Line	Status
<b>Ready</b>	Output 0	active
<b>End of Determination</b>	Output 3	active (impulse)
<b>Error</b>	Output 5	active



Input	7	6	5	4	3	2	1	0
Bit	7	6	5	4	3	2	1	0

(bits are always numbered from right to left)

Example: **SCAN\_RM Remote A Pattern \*\*\*\*\*1**

waits for an active input line 0 (1=set). This line is set by e.g. a Metrohm instrument when a determination has been finished and a start signal can again be accepted.

0 = inactive (high) 1 = active (low) * = arbitrary
--

Input lines which are not of interest or for which no defined condition can be predicted should be masked with an asterisk (\*).

It is of course possible to query several input lines simultaneously with a bit pattern (e.g. with **\*\*\*10\*\*1**), whereby all line statuses must correspond to the set bit pattern (e.g. for synchronization of several instruments). Under synchronization signal impulses may not be recorded under all circumstances as at a particular moment in time all line statuses must correspond to the bit pattern.

## CTRL\_RM

### Setting the output lines of the remote socket

The output lines can be set individually. Signal impulses can be created by two CTRL commands which follow each other. The first command sets the line to active (1), the second resets the status to inactive (0). The impulse length ( $\geq 1$  s) is defined by the line time of the first CTRL command.

Command	Parameters	Parameters
<b>CTRL_RM</b>	Remote	<b>A</b> Pattern *****

Both the output lines of the remote socket of the Titroprocessor itself as well as those of a connected 717 Sample changer can be set. The remote socket of the sample changer is provided with 14 output lines.

## Remote

## Remote socket address

**A / 1 / 2**

The remote socket of the Titroprocessor has the address **A**; the remote socket of a sample changer is always either **1** or **2**.

**Pattern** **Bit pattern for status of lines**  
*8 characters (0 | 1 | \*)*

The 8 or 14 output lines of the remote socket can be set at will. This is done by setting an 8 or 14-place bit pattern, in which each bit is assigned to an output line.

Output	13	12	11	10	9	8	7	6	5	4	3	2	1	0
Bit	13	12	11	10	9	8	7	6	5	4	3	2	1	0

(Bits are always numbered from right to left)

Example: `CTRL_Rm Remote A Pattern *****1`  
 sets the output line 0 to active (=set), which, for example, if a Metrohm Ion meter is connected would have the effect of a start command.

0 = inactive (high)  
 1 = active (low)  
 \* = no change

It is recommended that input lines which are not relevant should be masked with an asterisk (\*) so that their status is not altered.

A line set with a **CTRL** command (1) remains statically active. Under some circumstances it may be necessary to reset it at a certain time (0).

It is of course possible to set several output lines at the same time with a more complex bit pattern (e.g. `*****1*****0001`).

**8.13.3 RS 232 interfaces**

The RS 232 interfaces of the 796 Titroprocessor together with the corresponding communication commands allow very flexible solutions for demanding automation applications to be programmed. For example, as well as data communication with computers, Metrohm instruments which understand the Metrohm remote language can be remotely controlled by the Titroprocessor to their full extent; various functions of a modern analytical balance can also be used such as text display of the balance display, etc.

Just as with remote interfaces it is possible both to transmit data (character sequences) and also to interpret incoming character sequences (scanning).

When the RS 232 interfaces are used it is an absolute necessity that the transmission parameters of the instruments concerned are the same (see page 44f). When the data communication commands **CTRL\_RSx** and **SCAN\_RSx** are used one of the communications interfaces should be selected and the data communication mode set to '**LIMS**'. The use of the **SCAN\_RSx** command requires that the data receive mode of the particular interface is switched on. No other instruments such as printers, etc., should

be defined for the communications interface as their operation could be negatively influenced.

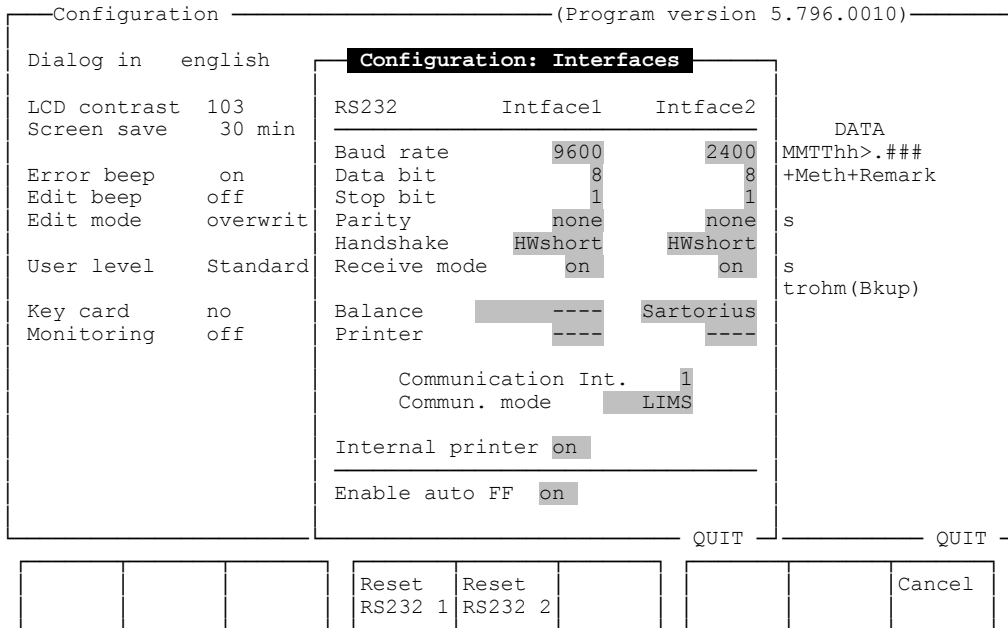

Data lines (ASCII strings) are transferred from the 796 Titroprocessor; these are terminated with the control characters **C<sub>R</sub>** and **L<sub>F</sub>**. This is also an absolute necessity for character sequences which are transmitted to the Titroprocessor.

The special syntax of the Metrohm remote language is used for controlling Metrohm instruments via the RS 232 interfaces. The most frequently used remote control commands or messages with Metrohm instruments are:

Function	Character sequence	Effect
<b>Start</b>	&M;\$G	starts the loaded method
<b>Stop</b>	&M;\$S	stops the active method

The most frequently used remote status messages with Metrohm instruments are:

Message	Character sequence	Meaning
<b>Ready</b>	*R"	ready message
<b>Error</b>	*;E*	error message

**CTRL\_RS1, CTRL\_RS2** **Send character string**

The Titroprocessor sends a character string with up to 50 characters to RS 232 interface 1 or 2 which is terminated as a data line with a **C<sub>R</sub>** and an **L<sub>F</sub>** character. It must be ensured that the connected instrument is ready to receive data and can accept data in this form. Many instruments are able to confirm data receipt with a status message or if need be to send an error

message. In this case it is advisable to pick up such a message with the **SCAN\_RSx** command (see below).

Command	Parameters	Parameters
<b>CTRL_RS1</b>		

For longer data or command sequences several **CTRL** commands can be programmed one after another; these are always transmitted as data lines with max. 50 characters.

**Parameter** **Character string / data**  
*up to 50 characters*

Any letters, numbers and special characters can be used. Make sure that these can also be interpreted by the receiving instrument.

---

**SCAN\_RS1, SCAN\_RS2** **Interpret incoming data**

In a sequence the **SCN\_RSx** command has the effect of stopping the method run until the predefined character string (up to 50 characters) has been received via the serial RS 232 interface. Incoming data are checked character by character.

Command	Parameters	Parameters
<b>SCAN_RS1</b>		

**Parameter** **Character string**  
*up to 50 characters*

Any combination of letters, numbers and special characters can be selected. **\*\*** can be used as place holder for any character sequence. (If **\*\*** is to be interpreted as an ASCII character then **\*\*\*** must always be used.) A place holder can be set within a character string. When the first part of the character string has been correctly recognized a search is made for the first appearance of the character which follows the **\*\***. The comparison of the second part of the character string is carried out here.

If a **SCAN\_RS** command is used in a series of samples it is recommended that the RS 232 interface used is first re-initialized. This has the effect of clearing the input buffer of the interface and is carried out by pressing **[Config.] [Interfaces] [Reset RS232 X]** on the Titroprocessor main page.

### 8.13.4 Other communication commands

Further communication commands are available for special applications.

---

#### **PRINT** **Print out text line**

The PRINT command prints out a single line on the printer defined in the configuration.

Command	Parameters	Parameters
---------	------------	------------

<b>PRINT</b>		
--------------	--	--

**Parameter**

**Text line**

*up to 50 characters*

Any letters, numbers and special characters can be entered.

---

#### **KEYCTRL** **Switch key remote control mode on/off**

In order to allow the remote control of the 796 Titroprocessor by a computer it is possible to switch the communication mode of an RS 232 interface to the key simulation mode **KEYCTRL** during a method run. In this mode the Titroprocessor keyboard is blocked. The instrument can only be operated via the RS 232 interface.

Command	Parameters	Parameters
---------	------------	------------

<b>KEYCTRL</b>	State	off
----------------	-------	-----

## 8.14 Auxiliary commands

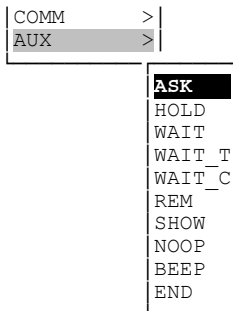

The 796 Titroprocessor offers numerous auxiliary commands for optimizing a method run.

Correct use of these auxiliary commands can help to improve operator-friendliness and simplify the Titroprocessor operation. Operating errors can be reduced.

### ASK

### Sample data query

In order to prevent the Titroprocessor operator from forgetting to enter the sample weight an input window can be called up during a method run in which the sample data can be entered.

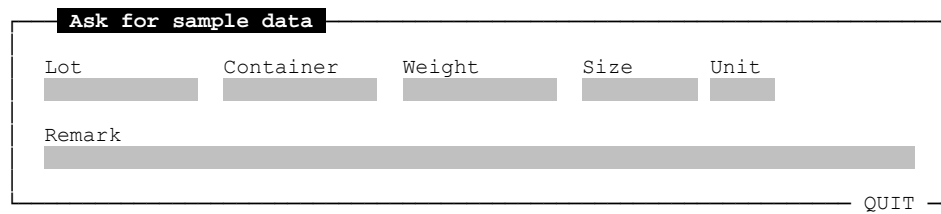

The window appears and shows the current sample data so that only the individual input field which needs to be altered can be edited. If the sample silo is switched on the offered data are taken from the current silo line. Of course, the sample data can be automatically received directly from a balance in this input window. This is also possible with a bar-code reader, whose data can be entered directly into the selected input field.

Command	Parameters	Parameters
ASK	Ident. item	Size yes

The behavior and input possibilities can be adapted to suit the requirements for the ASK window.

### Ident. item

### Sample identification input

*none | 1 | 2 | 3 | 1+2 | all*

The sample identifications permitted for input (**Ident1...3**) can be freely selected. Input fields which are not shown for the input of data retain their former values. Entries for all sample identifications can be made on the 796 Titroprocessor main page. The input field entries can be freely selected under **[Config.] / [Config. idents.]**.

This also applies when the sample silo is being used. In this case the entries in the input fields can be edited under [**Sample silo**] / [**>> >>**] [**Sample idents**].

<b>none</b>	no sample ident queries
<b>1</b>	only query Ident1
<b>2</b>	only query Ident2
<b>3</b>	only query Ident3
<b>1+2</b>	query Ident1 and Ident2
<b>all</b>	query Ident1...3

The input of a sample remark is always possible in the ASK window.

**Size** **Query mode for sample weight**  
*no | yes | confirm.*

A sample weight query can be made in different ways.

<b>no</b>	no sample weight query
<b>yes</b>	after sample weight input the ASK window is closed automatically
<b>confirm.</b>	Sample weight input possible, the ASK window must be closed with <b>&lt;QUIT&gt;</b> .

---

**HOLD**
**Interrupt method run**

The method run can be interrupted with the HOLD command. From the Hold condition the method can be restarted with the **<HOLD / CONT>** key or **<QUIT>**. In the Hold condition the yellow keyboard keys can be used (e.g. **<MAN CONTROL>**, **<PRINT>**). In this way it is possible to operate the different peripheral devices in the Hold condition.

**Parameters**
**Display text of HOLD window**

*50 characters*

A text can be entered for display in the Hold window. Example:

```

      Message
-----
Hold:
----- Add sample now! -----
                Press <HOLD/CONT>
----- QUIT -----

```

---

**WAIT**
**Waiting time in method run**

The method run can be interrupted for a preset time (in seconds) with the WAIT command. The duration of the interruption is defined with the line time of the command line. If no line time is given then the method run will remain interrupted until the WAIT display window is closed with the **<QUIT>** key. This is also possible if a defined waiting time has to be prematurely terminated.

t/s	Command	Parameters	Parameters
10	<b>WAIT</b>		

**Parameter**

**Display text in WAIT window**

*50 characters*

A text can be entered for display in the WAIT window. Example:

```

Message
-----
Wait:
----- Please wait 10 seconds! -----
QUIT
    
```

**WAIT\_T**

**Continue method run at set time**

The **WAIT\_T** command interrupts the method run and continues it at a defined time. A requirement for the sensible use of this command is that the system time of the 796 Titroprocessor is correctly set. In this way, e.g. it is possible to start a sample series at a particular time by programming the **WAIT\_T** command in a (**OMOVE** start sequence at the start of a method.

Command	Parameters	Parameters
<b>WAIT_T</b>		08:49:55

**Parameters**

**Time**

The time must be entered in the format hours:minutes:seconds (hh:mm:ss).

```

Message
-----
Wait until
time 08:50:00 cur. time 07:25:23
QUIT
    
```

The message window can be closed with **<QUIT>** and thus the method run can be continued before the defined time has been reached.

**WAIT\_C**

**Wait for conditioning**

The **WAIT\_C** command only makes sense in combination with a previous conditioning command such as **SEC** or **KFC**. Conditioning is basically carried out in the background. As soon as the **WAIT\_C** command is reached in the method run this takes control of the conditioning process and the **WAIT\_C** window is shown. The **WAIT\_C** command defines the behavior when the conditioned state of the sample has been achieved.

t/s	Command	Parameters	Parameters
99999	<b>WAIT_C</b>		

The line time entry controls the run. No line time entry has the effect that, when the conditioned state has been achieved, the method run immediately continues with the next command. An entry in the line time column provides a minimum duration for the conditioning. When the conditioned state is achieved the method run is continued automatically. For Karl Fischer titrations input of as high a minimum duration as possible is recommended (e.g. 99 999 seconds); the KF titration should be started manually with the <START> key when the conditioned state has been achieved.

**Parameters****Display text for WAIT\_C window***50 characters*

A text can be entered for display in the WAIT\_C window.  
Example:

```

      Message
-----
Wait      Conditioning
----- Conditioning running -----
                                     START
  
```

The display window can be closed with the <QUIT> key. The Titroprocessor can then be operated normally without influencing the method run or the conditioning. If the main window is exited and then re-opened, the **WAIT\_C** window will be shown again.

The conditioning state is shown in the trace window of the main page. In the conditioned state the following programmed titration can be started by pressing the <START> key.

**REM****Comment line**

The REM command within a method is used for documentation purposes and has no effect on the method run. If a line time has been set for a REM command the REM command can be used to delay the run (no display text).

t/s	Command	Parameters	Parameters
	REM		

**Parameters****Comment text***50 characters*

The comment text is used purely as a description within the method and does not appear when the method is carried out.

**SHOW****Control of the display screen**

Within a method run the display can be forced to switch to particular dialog pages.

Command	Parameters	Parameters
<b>SHOW</b>	Page	main

**Page**

**Show dialog page**

*curve | result | stat. | main*

Depending on the selected dialog page the switch is either made immediately or at the end of the determination.

<i>curve</i>	immediate switch to live curve display
<i>result</i>	switches to results display at end of determination
<i>stat.</i>	switches to statistics results display at end of sample series
<i>main</i>	display immediate switches to main page

**NOOP**

**No operation, place holder command**

The **NOOP** command can be used to arrange the command blocks. It does not trigger any actions in the method run.

**BEEP**

**Acoustic signal**

The **BEEP** command is used to produce an acoustic signal.

**END**

**End marker**

Each method must contain an **END** command. This is used to mark the end of the method. Normally the END command is set in the last method line. For test purposes in a complex method the insertion of further **END** commands may be useful, e.g. in a **CASE** sequence. The method will then be processed until the first **END** marker is reached.

**STIR\_I**

**Control of internal stirrer connections**

The stirrer connections of measuring groups A and B can be switched directly in a method. Stirrer models 728 (magnetic stirrer), 722 (rod stirrer) or the 703 or 727 Titration stands (with magnetic stirrer) are suitable for use on the internal connections of the measuring interfaces.

Command	Parameters	Parameters
<b>STIR_I</b>	Meas. interface	A State on

After switch-on the stirrer connections are also switched on. The stirrers connected to the measuring groups can also be operated manually; see **<MAN CONTROL>** key.

**Meas. interface****Stirrer connection address***A | B*

The Titroprocessor models 2.796.0110 and 2.796.120 have 2 measuring interfaces (**Sensors A** and **Sensors B**). The other models only have measuring interface **A**.

---

**Status****Stirrer on/off***on | off*

In contrast to stirrers for sample changer operation the stirrer speed of the internally connected stirrers cannot be controlled. They can only be switched on or off.

# 9 Results and statistics

When a determination has been completed the calculations which have been defined in the method are carried out. The results are shown on the results page. The evaluation of the measuring data can be carried out at a later date with altered evaluation criteria. Sample data and calculation formulas can also be altered for later calculations.



**Alterations which are carried out for a later evaluation or calculation are not automatically incorporated in the method. Subsequent determinations will still be carried out with the settings defined in the original method!**

**The corresponding method does not need to be loaded in order for later re-evaluations to be carried out.**

## 9.1 Results page

The results page is called up from the main page with the [Results] softkey.

Titration or measuring mode with command line and comments

Name of the determination file

Bar cursor

Result attribute

```

Results: HALIDES.001 Original data
# 3 DET U* Determination of halides
EP1 -359.7 mV 1.029 mL vol.iodide 1.029 mL
EP2 -146.9 mV 4.700 mL vol.bromide 3.671 mL
EP3 169.6 mV 7.510 mL vol.chloride 2.809 mL
iodide 81.78 mg/L
bromide 183.72 mg/L
chloride 62.38 mg/L
Error list:

```

EP list with measured value and EP volume

Results list with comments

List of errors which have occurred

QUIT

Sample data	Select	Determ. report	* Param	* Formula	* Report	Local ComVars	Calib. data	>>	>>
-------------	--------	----------------	---------	-----------	----------	---------------	-------------	----	----

The second softkey bar:

Extend. values	File	Statistics		Recalc all	Recalc one			>>	>>
----------------	------	------------	--	------------	------------	--	--	----	----

In the results window all necessary alterations for re-evaluations can be carried out.  
 If several titration and measuring modes have been carried out in a single determination then their results are listed underneath each other.  
 If the parameters have to be altered then the data record involved must first be selected with the bar cursor.

Example:

```

Results: 9921011.011 Original data
# 1 MEAS_PH* pH measurement
IM pH 4.356 pH value 4.36 pH
CM pH 4.357
# 2 DET_PH* Free Acid
EP1 pH 7.110 4.727 mL acid content 55.2 mol/L
Error list:

```

QUIT

Sample data	Select	Determ. report	* Param	* Formula	* Report	Local ComVars	Calib. data	>>>
-------------	--------	----------------	---------	-----------	----------	---------------	-------------	-----

## Softkeys

**[Sample data]** opens an entry window for altering the sample data.

**Sample data**

```

User [ ] Run number 001
Method Ident1 Ident2 Ident3 Size Unit
[ ] [ ] [ ] [ ] [ ] [ ]
Remark [ ]

```

QUIT

**[Select]** opens a selection list with the determinations contained in the working memory. When one of these is selected its results are displayed.

**[Determ. report]** opens the dialog window for altering the determination report, see page 75ff.

[\*Param] allows the EP recognition criteria and the curve display to be processed.

EP Recogn.	Curve display	
---------------	------------------	--

See pages 139ff and 142ff.

[\*Formula] opens the dialog window for altering the calculation formulas for recalculations, see page 119ff.

[\*Report] opens the dialog window for altering the report of the selected data record.

[Local ComVars] opens the dialog window for altering the local common variables. These are copies of the common variables which were valid at the time of the determination.

[Calib. data] opens a window to display the calibration data for pH measurements and pH titrations.

Calibration data	
Meas. input	A1
Cal. sensor	
Cal. method	manual
Cal. date	1999-12-10
Cal. time	14:19:08
Temperature	25.0 °C
pH(as)	6.956
Slope	0.998

QUIT

These are the calibration data which were valid at the time of the determination.

[>> >>] switches to the second softkey bar.

[Extend. values] opens a window for displaying further values of the selected titration or measurement. These are the data which are stored in the system variables.

Extended Values: #2 DET_pH*		
Initial		
time		14:38:13
meas. value	IM pH	4.701
temperature	IT	25.0 °C
Start		
meas. value	SM pH	4.704
volume	SV	4.507 mL
temperature	ST	°C
duration	SD	38.6 s
Closing		
meas. value	CM pH	9.132
volume	CV	8.701 mL
temperature	CT	°C
Measure duration	MD	220.5 s
Stop condition		meas. value

QUIT

System variables

- [File]** opens the file dialog window for storing or loading determination files.
- [Statistics]** opens the display window for the statistical data , see below.
- [Recalc all]** recalculates all results of the determinations in the working memory. All alterations, including those to the endpoint recognition, will be taken into account.
- [Recalc one]** recalculates the results of the indicated determination. All alterations, including those to the endpoint recognition, will be taken into account.
- [>> >>]** switches to first softkey bar.

As soon as a determination has been recalculated then this is noted in the frame on the results page. The entry '**Original data**' changes to '**Modified data**'.

```

Results: 97121015.017 Modified data
# 1 MEAS_PH* pH measurement
    
```

### 9.1.1 Statistics

The statistics results of a sample series are shown in the statistics window . This requires that the calculation formulas have been defined in the method as statistics results ('**statist.**').

The statistics can comprise all results from 20 determinations. These determinations must all be contained in the working memory. As each determination can contain up to 50 results (including intermediate results and common variables) this means that 1000 individual values are theoretically possible.

Results: 99121015.005 Modified data

**Statistics**

5 of 5 Determinations

	pH value R1 / pH	acid content R2 / mol/L	/	/	/
97121015.001 om	6.71	0.52			
97121015.002 om	7.20	0.63			
97121015.003 om	7.62	0.65			
97121015.004 om	8.36	0.73			
97121015.005 om	8.10	0.71			

n = 5

Mean = 7.60      0.648

S.dev +/- = 0.667      0.08

= 8.78 % = 12.35 % = %      = %      = %

QUIT

The results are organized in columns which are arranged in the sequence of the occurrence of the result variables (**Rxx**, **Xxx** or **Cxx**).

5 results columns are visible at once. The **<TAB>** or **<→>** keys are used to switch to the next column or statistics page. **<↑><TAB>** or **<←>** switch to the previous column or page. The cursor keys **<↓>**, **<↑>** and **<PG DN>** or **<PG UP>** are used to move the cursor within a column.

If the statistics function is switched on (main page '**Statistics on**') then determinations can later be copied into the working memory. After renewed recalculation with the **[Recalc all]** softkey on the results page these will then be included in the statistics.

Single results can be excluded from calculation of the statistical data by selecting the relevant result with the cursor keys and pressing the **[Un/Mark]** softkey. The statistics will then be recalculated immediately. Results suppressed in this way are marked with an **!** sign. The marking can be removed in the same way.

The file names in the determinations are marked with 2-place file attributes. They show how the results of the particular determination have been achieved.

The first file attribute character stands for the method used for the determination. The second character stands for the type of calculation.

Attribute	Method	Calculation
<b>o</b> = original	unmodified	unmodified
<b>n</b> = new	new, not stored	
<b>m</b> = modified	loaded and modified	newly calculated

*Example:*

DATA.001 **om**

This means that the determination DATA.001 was carried out with a stored and unmodified method. The results were later recalculated with either altered formulas or altered sample data.

## 9.2 The <RESULT> key

An alternative view of the results is offered by the <RESULT>key. No alterations can be carried out here.

Result			
Determination : 99121015.005		Modified Data	View: Determ.
Comment	Formula	Value	Unit
# 1 MEAS_PH*	pH measurement		
pH Value	R1	8.10	pH
# 2 DET_PH*	Free acid		
acid content	R2	0.71	mol/L

QUIT

Statist view	Select determ.	
-----------------	-------------------	--

The [**Select determ.**] softkey can be used to select a determination from a selection list in the working memory in order to assess its results.

The [**Statist view**] softkey switches the display to show the statistical data, see below.

Result			
Modified data		View : Statistics	
Comment	Formula	Mean	S.dev +/- Unit
pH value	R1	7.60	0.667 pH
acid content	R2	0.648	0.08 mol/L
			s in % n
			8.78 5
			12.35 5

QUIT

Determ. view		
-----------------	--	--

The [**Determ. view**] softkey switches the display to show the results of a single determination, see above.

# 10 Curves and re-evaluation

## 10.1 Single curves

By pressing the [Show curves] softkey on the main page titration curves can be shown.

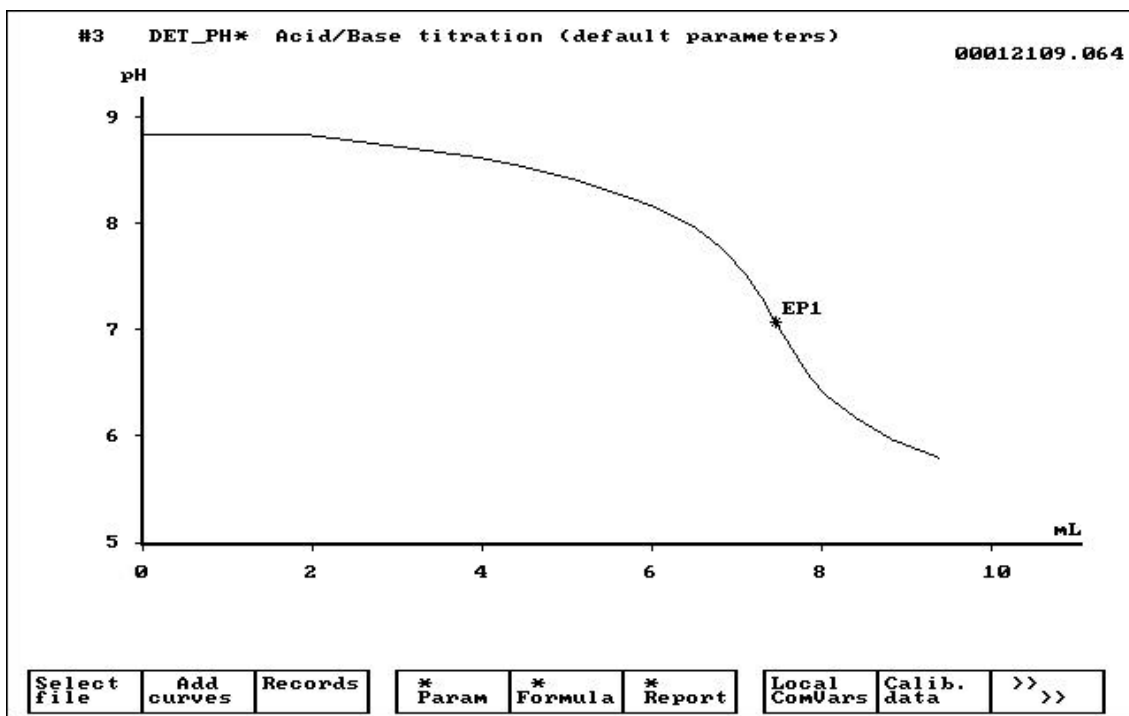

A curve can only be shown when a measuring point list containing at least 4 measuring points of a titration or a series of measurements is available.

The representation of the curve can easily be altered. In the same way as the alterations on the results page, these alterations are only temporarily valid, i.e. modifications to the presentation of the curve do not alter the method.

It is possible to load the curve of a different determination directly from this screen. Several curves of the same type can be overlapped for a direct comparison.

### Softkeys

**[Select file]** shows the selection list of the determinations contained in the working memory. If several titrations or measurements are contained in one determination then the required curve can be selected from them. The selected curve is shown according to its presentation parameters.

- [Add curves]** shows the selection list for similar types of determination contained in the working memory. If a curve is selected it will be added to the curve already shown.
- [Records]** opens a selection list with the available curves for the current determination, i.e. those titrations or measurements which have been carried out in the actual determination. After confirmation with **<ENTER>** the selected curve will be shown.
- [\*Param]** allows the EP recognition criteria and the curve display to be processed.

EP Recogn.	Curve display	
---------------	------------------	--

See pages 139ff and 142ff. Please note that the curve presentation on the time axis is only possible if time recording was switched on for the corresponding determination, see page 135.

- [\*Formula]** opens the dialog window for altering the calculation formulas for recalculations, see page 119ff.
- [\*Report]** opens the dialog window for altering the reports of the selected data records.
- [Local ComVars]** opens the dialog window for altering the local common variables. These are copies of the common variables valid at the time of the determination.
- [Calib. data]** opens a window for displaying the calibration data for pH measurements and pH titrations.

Calibration data	
Meas. input	A1
Cal. sensor	
Cal. method	manual
Cal. date	99-12-10
Cal. time	14:19:08
Temperature	25.0 °C
pH(as)	6.956
Slope	0.998
QUIT	

These are the calibration data which were valid at the time of the determination.

- [>> >>]** switches to the second softkey bar.

**[Sample data]** opens an entry window for altering the sample data.

**Sample data**

User  Run number 001

Method  Ident1  Ident2  Ident3  Size  Unit

Remark

QUIT

**[Show cursor]** selection of a graphics cursor for displaying the data of the individual measuring points or equivalence points. Select '**M.pts**' or '**EPs**', see below.

### Graphics cursor

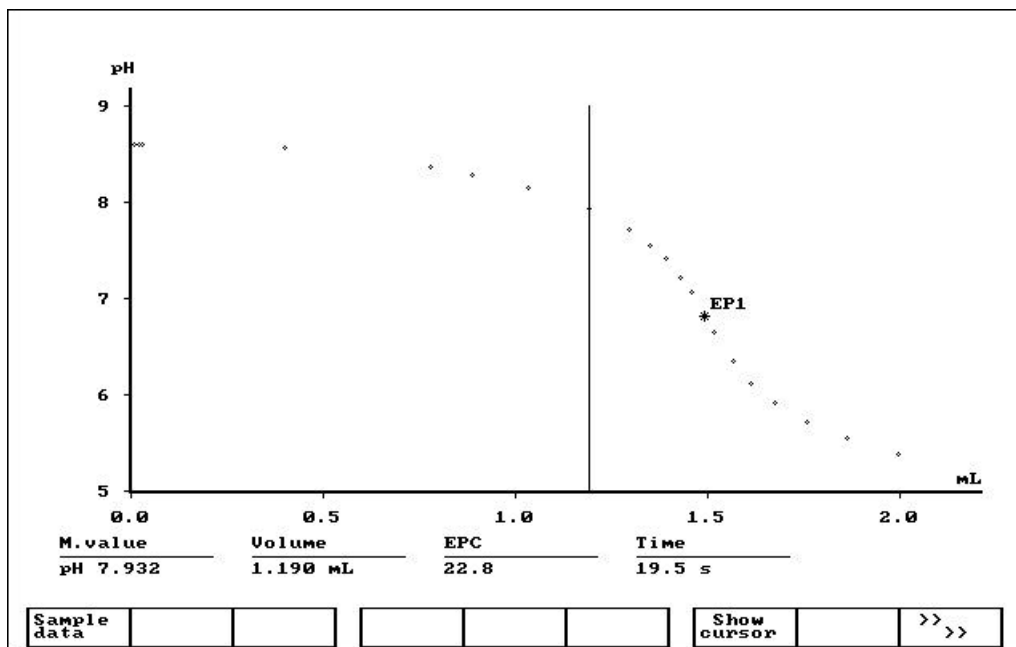

With the **[Show cursor]** softkey a line cursor can be switched on which can 'wander' along the measuring curve, i.e. a vertical line cursor can be moved from one measuring point to the next with the **<←>** and **<→>** keys. The corresponding values for measurement, volume, endpoint criterion (for DET) and time are indicated for the particular measuring point chosen.

The same function is available for the display of equivalence points. A cross-wires cursor shows the corresponding data of the different equivalence points.

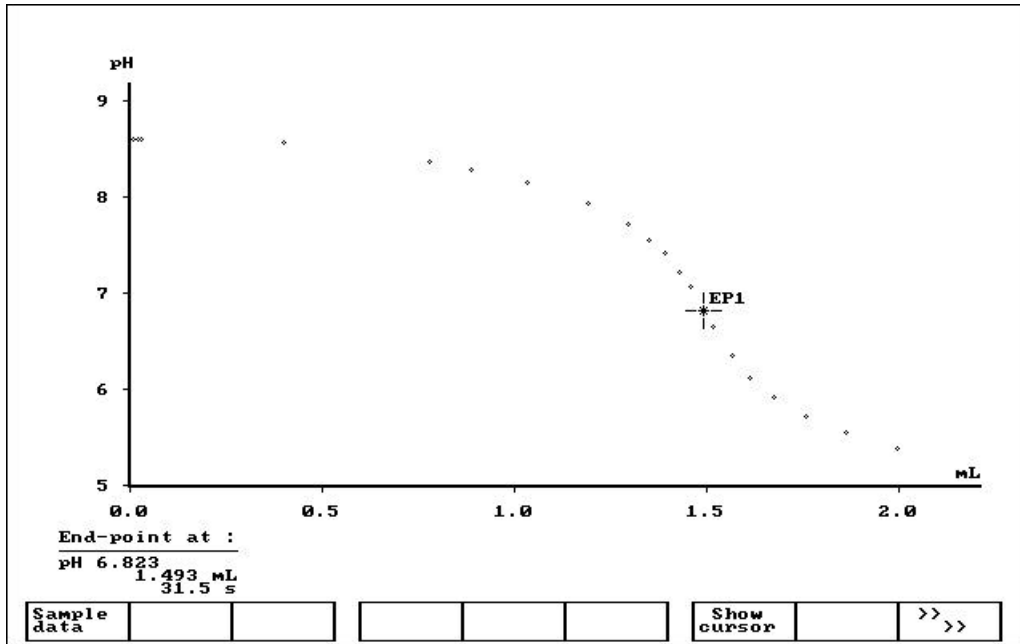

The  $\uparrow$  or  $\downarrow$  keys switch the graphics cursor off again. These functions are also available for overlapping curves.

## 10.2 Overlapping curves

Several curves of the same type (same methods, same modes, same presentation size) can be overlapped and compared on the screen. Make sure that the corresponding determinations are loaded in the working memory. Use the file manager for this if necessary.

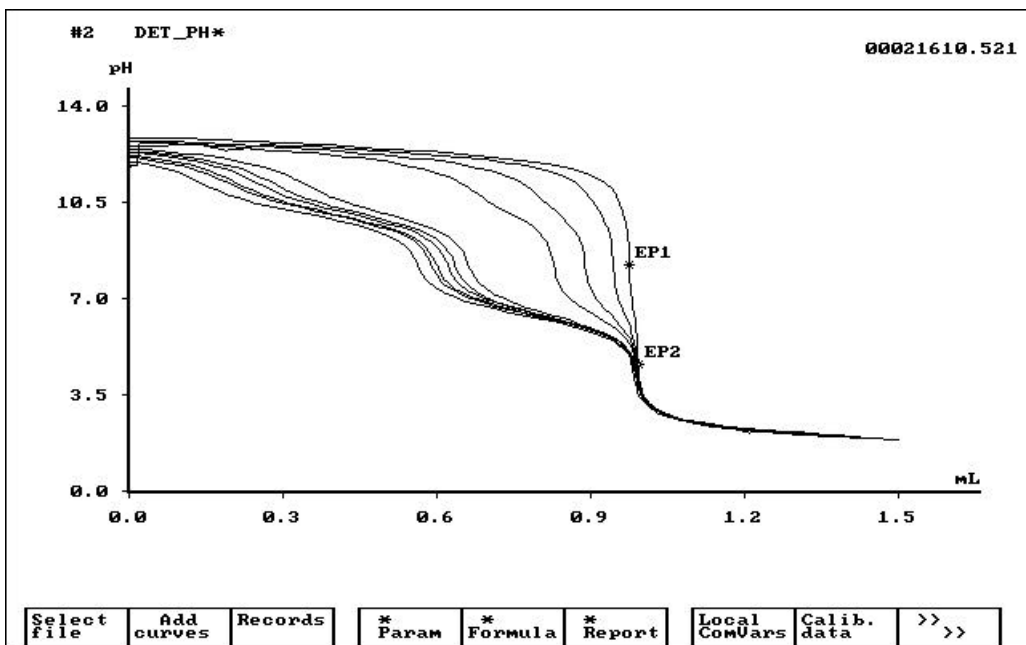

- First select a curve to be displayed with the ([**Select file**]) softkey. Set the display parameters so that all curves can be shown ([**\*Param**] [**Curve display**]) softkeys. If 'auto' is selected for the axis scaling then all curves will be adapted automatically.

- Press [**Add curves**] in order to display a selection list of the curves in the working memory which can be compared with each other. One or more curves can now be selected.
- Hold down the <↑> (Shift) key and press the cursor key <↑> or <↓>. The selected curves will be marked with the '✓' sign and displayed when the <ENTER> key is pressed. The same method can be used to remove curves again.

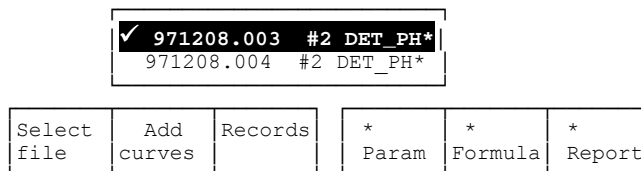

Overlapping curves are shown in light gray except for the active curve. The <↑> and <↓> keys are used in order to select a particular curve. This then becomes the active curve and is shown in black. The corresponding name of the determination file is shown in the title line. Only the EPs of the active curve are visible.

### 10.3 Curve presentation

The presentation of the curves of a titration or series of measurements can be altered at a later date. All those settings are available which are possible for the titration or measuring mode. Please note, for example, that for the presentation of curves on the time axis or the presentation of derivative curves in the **SET** mode the necessary data must be present in the measuring point list. The corresponding settings (**Time recording**, **Derivation** ...) must have been used in the determination, see page 151f.

The settings for the curve display can be found in the curve window under the softkeys [**\* Param**][**Curve display**].

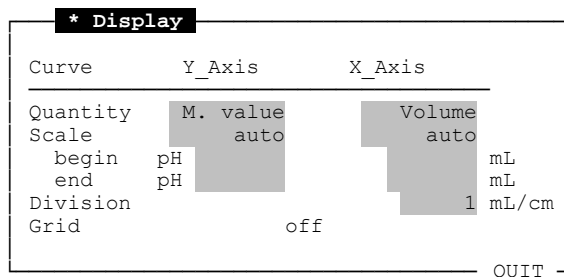

Quantity Y\_Axis

Quantity on the Y-axis

*M. value* | *Volume* | *Temp.* | *dMV/dV*  
*dMV/dt* | *dV/dt* | *MV,Temp* | *MV,dMV/dV* | *all*

Apart from the standard presentation of measured value/volume other forms of presentation are possible.

The selection of quantities on the Y-axis:

<i>M. value</i>	pH, mV or $\mu\text{A}$ (depending on mode)
<i>Volume</i>	i.e. volume against time
<i>Temp.</i>	only for automatic measurements
<i>MV, Temp</i>	measured value and temp. combined
<i>dMV/dV</i>	measured value derived from volume
<i>dMV/dt</i>	measured value derived from time
<i>dV/dt</i>	added volume derived from time
<i>MV,dMV/dV</i>	measured value, and measured value derived from volume, combined
<i>all</i>	all curves which can be shown,combined

---

<b>Quantity X_Axis</b>	<b>Representation size on the X-axis</b> <i>Volume   time</i>
------------------------	--

Titration curves can be shown against volume or time. Presentation on the time axis is only possible if time recording (see page 151) has been switched on.

---

<b>Scale</b>	<b>type of axis scaling</b> <i>auto   fixed</i>
--------------	--

Both axes of the curve can be scaled automatically by the Titroprocessor. If a fixed scale is required then it is essential that all scale parameters are entered (see below).

---

<b>begin ... end</b>	<b>Limiting values of fixed axis scales</b>
Y-axis:	<i>pH -20...20   -2000...2000 mV -200...200 <math>\mu\text{A}</math>   ERC 0...200</i>
X-axis:	<i>0...999.99 mL   0...999 999 s</i>

The limiting values of the axis scales can be set at will within the particular measuring range. Fixed limiting values are only effective if the scaling has been set to *'fixed'*.

---

<b>Division</b>	<b>Distance between the divisions on the X-axis</b> <i>0.01...1...99.9 mL/cm 0.01...30...99.9 s/cm</i>
-----------------	---

The scale divisions of the X-axis only apply to the printout of the titration curve.

**Grid** Titration curve grid on / **off**

The titration curve grid is only shown on the titration curve printout. It cannot be shown on the screen.

An alteration to the representation parameters has a direct effect on the presentation of the curve.

The curve can be printed out in the new presentation by pressing the, <**PRINT SCREEN**> key or reproducing a complete curve report. By pressing the <**PRINT**>key the printer dialog window opens. After the required mode has been selected with the cursor keys the [**Select report**] softkey allows the selection of the possible reports. Select either **V\_Curve** (volume curve) or **T\_Curve** (time curve) and then the quantity to be shown.

### 10.4 Re-evaluation

For a re-evaluation (only for **DET** and **MET** modes) all settings which have an effect on the recognition of the equivalence point can be altered by pressing the softkeys [**\* Param**] and [**EP Recogn.**].

EP Recognition						
Equivalence points		window		min. EPC		5.0
Gen. lower limit	pH	min		upp. pH		max
pK/HNP Evaluation						off
Windows				Fixendpoints		
EP#	from ...	to	[pH]	EPC	[ ]	F# M.value [pH]
1	min	max		5.0		1 off
2	off	off		5.0		2 off
3	off	off		5.0		3 off
4	off	off		5.0		4 off
5	off	off		5.0		5 off
6	off	off		5.0		6 off
7	off	off		5.0		7 off
8	off	off		5.0		8 off
9	off	off		5.0		9 off

QUIT

Details of the individual settings can be found on page 139ff.

Alterations of the evaluation parameters have no direct effect on the presentation of the curve. This requires the complete recalculation of the measuring data. This is done by changing to the results page. Press the [**Results**] softkey on the main page, change to the second softkey bar and press [**Recalc**]. This brings all result calculations up to date and shows the recalculated results.

The determination files with the newly calculated results and the altered settings can be stored in a new determination file in a selectable memory area by pressing the [**File**] softkey on the results page to call up the file dialog window.

# 11 File manager

## 11.1 File list

The file manager of the Titroprocessor 796 is a useful tool for managing methods, silo files or other files.

The file manager can be called up with the **[File manager]** softkey on the main page.

All file operations can be carried out in the working memory, in the internal memory or on a data card. Additionally, any files can be transmitted to or from a computer via an RS232 interface (with cable 6.2125.060 and the 796 backup software or a PC terminal program which supports the Kermit transmission mode).

The memory area can be changed with the **[Change storage]** softkey.

The capacity of each memory area is limited to 256 files.

File manager: Data card					
Label : 796 Applications			Files : 65 of 256		
Capacity: 262144 Bytes			Avail.: 4216 Bytes		
File	Date	Time	File	Date	Time
NaOH.mth	2000-01-11	07:16:12	HCl.mth	2000-01-11	07:16:33
Iodine.mth	2000-01-11	07:16:53	Chloride.mth	2000-01-11	07:17:16
Sulfate.mth	2000-01-11	07:18:46	CaMgTap.mth	2000-01-11	07:19:18
Hardness.mth	2000-01-11	07:21:45	Acidcapa.mth	2000-01-11	07:22:17
Tapwater.mth	2000-01-11	07:22:55	ClinTap.mth	2000-01-11	07:23:34
BlankS04.mth	2000-01-11	07:24:05	Sulphate.mth	2000-01-11	07:24:36
Oxiblack.mth	2000-01-11	07:25:14	Oxi.mth	2000-01-11	07:25:57
Oxygen.mth	2000-01-11	07:26:25	TAN.mth	2000-01-11	07:27:20
TBN.mth	2000-01-11	07:27:34	BromineI.mth	2000-01-11	07:28:06
BromineN.mth	2000-01-11	07:28:31	H2S.mth	2000-01-11	07:28:50
Formol.mth	2000-01-11	07:29:34	Peroxide.mth	2000-01-11	07:30:01
IodineNo.mth	2000-01-11	07:30:35	VitCOrag.mth	2000-01-11	07:31:22
Clinmeat.mth	2000-01-11	07:31:48	Cainmilk.mth	2000-01-11	07:32:08
Diazo.mth	2000-01-11	07:32:34	NaCliso.mth	2000-01-11	07:32:58
VitCphot.mth	2000-01-11	07:33:20	EDTANTA2.mth	2000-01-11	07:33:41
Cationic.mth	2000-01-11	07:34:01	Anionic.mth	2000-01-11	07:34:20
Perborat.mth	2000-01-11	07:34:42	AnT-r3.mth	2000-01-11	07:35:06

QUIT

Change view	Change storage	Un/Lock file	Load from	Copy to	Delete	Un/Mark all	Un/Mark all	>>>
-------------	----------------	--------------	-----------	---------	--------	-------------	-------------	-----

The file manager page shows the contents of a memory area in a window (<PG UP> or <PG DN> can be used for page turning).

A file list can be shown in two different ways. Press the **[Change view]** softkey in order to change from the file name/date/time display (see above) to the file name/comments/size display (see following page) and vice-versa.

```

File manager: Data card
Label   : 796 Applications
Capacity: 262144 Bytes
Files  : 65 of 256
Avail. : 4216 Bytes
    
```

File	Comment	Size
NaOH.mth	Titer of NaOH	3816
HCl.mth	Titer of HCl	3819
Iodine.mth	Iodine determination	3722
Chloride.mth	Determination of chloride	3673
Sulfate.mth	photometric sulphate determination	3712
CaMgTap.mth	Calcium / Magnesium in tap water	3746
Hardness.mth	total water hardness by photometric titration	3810
Acidcapa.mth	acid capacity in tap water	5179
Tapwater.mth	Total water hardness	7998
ClinTap.mth	Chloride in tap water	3735
BlankS04.mth	Blank determination for sulphate in water	3994
Sulphate.mth	Sulphate in water samples	4062
Oxiblack.mth	Blank of Oxidizability	5452
Oxi.mth	Oxidizability of waste water	3847
Oxygen.mth	Oxygen in water	3615
TAN.mth	Total Acid Number	3657
TBN.mth	Total Base Number	3657

QUIT

Change view	Change storage	Un/Lock file	Load from	Copy to	Delete	Un/Mark	Un/Mark all	>>	>>
-------------	----------------	--------------	-----------	---------	--------	---------	-------------	----	----

## 11.2 File operations

It is strongly recommended that a data card **is not removed** during file operations!

### Softkeys

- [Change view]** alters the file list display
- [Change storage]** selects a different memory area (working memory, internal memory, data card)
- [Un/Lock file]** marks a file with an '\*' as blocked (write-protected) and vice-versa. A blocked file cannot be deleted or overwritten. It must first be unblocked.
- [Load from]** opens a selection list for selecting a memory area from which a file is to be copied into the memory area currently opened.
- [Copy to]** opens a selection list for the selection of the memory area to which the marked file(s) are to be copied. If no file has been marked then the file selected with the cursor will be copied.
- [Delete]** deletes the marked file(s). If no file has been marked then the file selected with the cursor will be deleted.
- [Un/Mark]** marks the file selected with the cursor and vice versa.
- [Un/Mark all]** marks or unmarks all files in the shown memory area.
- [ >> >>]** switches to second softkey bar.

[ <b>Send to RS</b> ]	opens the selection list for selection of the RS232 interface via which the marked file(s) are to be transmitted. If no file has been marked then the file selected with the cursor will be transmitted.
[ <b>Receive from RS</b> ]	opens the selection list for selection of the RS232 interface via which the marked file(s) are to be received.
[ <b>Sort by</b> ]	opens the selection list for selection of the sorting criteria of the file list. The following are available: ' <b>by name</b> ', ' <b>by comment</b> ', ' <b>by extension</b> ', ' <b>by size</b> ' and ' <b>by date</b> '. The sorting sequence can be set to ascending or descending.
[ <b>Select</b> ]	opens the dialog window for entry of the selection mask for marking particular files. The files are marked in which the criteria of the file name and the file comments agree ( <b>AND</b> linkage). The following wildcards are available for definition of the selection masks: <ul style="list-style-type: none"> <li>* = any character sequence</li> <li>? = any character</li> <li># = any number</li> </ul> <p>The files which meet the selection criteria are marked with an arrow '-&gt;' and sorted to the top of the file list.</p>
[ <b>Format card</b> ]	formats a data card. This can given a name. This softkey is only visible if the data card has been selected as the memory area.
[ >> >>]	switches to first softkey bar.

Please note that the Titroprocessor 796 differentiates between capital and lower-case letters and remember this when sorting the file list or choosing selection lists.

## 11.3 Format data card

In order for them to store data, data cards must first be formatted before they are used for the first time. The format of the file system created depends on the type of instrument. It is not possible to read in or write on data cards from other Metrohm instruments or cards with PC-readable file systems without first reformatting them in the Titroprocessor 796.

### Reformatting procedure

- Insert the data card (only SRAM cards) in the card slot.
- Open the Titroprocessor file manager.
- Press the [**Change storage**] softkey and select '**Data card**'.
- If the data card has never been formatted or has an unreadable file system this will be recognized by the Titroprocessor and a query about formatting the card will appear.

- If the card already has the correct file system then it can be formatted with the [**Format card**] softkey. (This softkey can be found on the second softkey bar; press [**>> >>**].)
- After the safety query appears and has been answered with '**Y**' a name for the data card can be entered. After confirmation with **<ENTER>** the data card will be formatted.

**Warning!** If data cards which have already been used are formatted then all the data they contain will be lost.

Please read the information about the use of data cards given on page 5 and consult the documentation accompanying the card.

## 11.4 File backup

It is a good idea to backup method or determination files regularly on a personal computer. The files can be transmitted to the PC via an RS232 interface. They can be stored on the hard disk or on a floppy disk.

The 'Metrodata 796 PC backup'-software (6.6026.010) is required for this, together with a serial 6.2125.060 cable to connect the Titroprocessor with the PC. A PC terminal program can be used as an alternative; this must support the Kermit transfer protocol. For setting the data transmission protocol see page 36.

### Interface configuration for data backup:

- Connect the serial cable to RS232 socket 1 or 2 of the Titroprocessor and to the **COM1** or **COM 2** connection of the PC.
- Under [**Config.**][**Interfaces**] set the communication mode of the corresponding RS232 interface to '**LIMS**'.
- The transmission parameters of the corresponding RS232 interface must be set as follows:

Baud Rate	9600
Data Bit	8
Stop Bit	1
Parity	none
Handshake	Hweinf

For transmitting files switch data reception to '**off**', for receiving them switch it to '**on**'.

The settings of the backup software must agree with the settings of the Titroprocessor interface.

- If problems occur during data reception it may be necessary to deactivate the FIFO buffer of the RS232 interface in the system settings of the computer or to reduce the baud rate of both instruments to 2400 Baud. Consult the instructions for use of the Metrodata 796 backup software.

In order to start data transmission the **'Receive'** or **'Send'** mode of the backup software at the PC must be switched on before the [**Send to RS**] or [**Receive from RS**] softkey of the Titroprocessor is pressed. After selection of the RS232 interface transmission takes place.

Files (method, silo data, determination files) can also be transmitted or received directly from the file dialog window of the corresponding dialog page. Select **'Storage'** **'RS232 x'** and press the [**Load**] or [**Save**] softkey.

# 12 Troubleshooting

---

## 12.1 Error messages

Error messages are accompanied by the name of the instrument module in which the fault has occurred. In addition, each error message is provided with a number so that it is easier to find the corresponding error message in the following list.

### A/D CONV

---

**A/D CONV 1:      XX not corr. sensor for DEVICES and METHODD**

In the method being carried out a sensor has been laid down which does not match the current entry on the dialog page 'Devices & Manual Control'. Check whether the correct sensor is being used. If necessary bring the entry up to date (<MAN CONTROL> key). If the comparison of the sensor names is not required this can be switched off by completely deleting the entry.

**A/D CONV 2:      X: check temperature sensor**

Either no temperature sensor has been connected to the sensor interface X, or it may have a fault.

**A/D CONV 3:      interface X busy**

- The sensor to be accessed is currently being used for an actual determination. Wait until this has been completed.
- A method in progress is trying to access a sensor which is currently being used for a manual measurement. This causes the determination to be interrupted ('HOLD'). It can be resumed by pressing the <HOLD / CONT> key as soon as the affected sensor is available again.

**A/D CONV 4:      interface X: unexpected error**

A fault has occurred which cannot be specified more closely. Please contact the service department of your local Metrohm agency and tell them the error message number.

**A/D CONV 5:      interface X not present**

An attempt has been made to access a sensor interface which has not been installed. Check the method.

---

**ARITHMETIC**

---

**ARITHMETIC 1: unexpected arithmetic error, code: XXXX**

An arithmetical error has occurred in an internal calculation while a method is being carried out. Check the current method.

---

**BALANCE**

---

**BALANCE 1: invalid sample size**

An invalid weight has been received. Check the balance settings.

**BALANCE 6: data for current sample are not admitted**

Invalid sample data have been received. Check the balance settings.

---

**CAL DATA**

---

**CAL DATA 1: calibration interval expired, sensor X**

The sensor mentioned should be subjected to a new sensor test. See page 280.

---

**CAL\_PARAM**

---

**CAL\_PARAM 1: buffer list full**

No further buffer can be defined. Delete unnecessary buffers from the list.

---

**CHANGER**

---

**CHANGER 1: no sample changer detected**

No sample changer has been connected.

**CHANGER 2: changer 'X' max. powerlimit reached**

The sample changer is overloaded or blocked. Check the sample changer.

**CHANGER 3: no rack data found on changer 'X'**

The magnet code of the rack placed on the sample changer cannot be assigned to any rack table. Define the corresponding rack data with the accompanying rack code under [Config.] [Sample changer].

**CHANGER 4: no rack code found for changer 'X'**

No magnet code can be read in at the sample changer. Use a rack with a valid rack code.

**CHANGER 5: changer 'X' not ready**

The sample changer is busy. Wait until it is ready and try the command again.

**CHANGER 7: changer 'X' not accessible**

The selected sample changer does not reply. Check the sampler connection 'External Bus' and the cable.

**CHANGER 8: changer 'X' already locked**

The selected sample changer is busy processing a series of samples. It cannot be accessed by manual operation.

**CHANGER 9: changer 'x' MOVE disabled, raise lift**

The MOVE command cannot be carried out because the/a lift is located below its shifting position. Raise the lift concerned to a safe position.

**CHANGER 10: changer 'X', unable to move lift**

The lift is blocked mechanically. Ensure that the lift can be moved and try again.

**CHANGER 11: changer 'X' no MOVE executed**

The preconditions for a MOVE\_S command have not been fulfilled. Check whether the position to be moved to has not been defined as special beaker (press [Config.] [Sample changer] select rack [Special beakers]).

**CHANGER 12: changer 'X', drive overload**

The sample changer turntable is blocked. Ensure that the rack can be turned and try again.

**CHANGER 13: changer 'X' invalid drive****CHANGER 14: changer 'X' common access failure YYYY**

There are connection problems between the sample changer and Titroprocessor. Please contact the service department of your local Metrohm agency.

**CHANGER 15: changer 'X', EBus timeout**

The connection between the Titroprocessor and sample changer has been interrupted. Check the 'External-Bus' connection socket.

**CHANGER 17:      illeg. rack and swing head combination, changer 'X'**

- A swing head is required on the sample changer for the rack placed on it. This must be entered in the sample changer configuration, see [Config.] [Sample changer] [Changer 1(2)].
- A swing head has been entered in the sample changer configuration. Use a sample rack designed for it or switch off the swing head (see above).

**CHANGER 21:      changer X busy**

An attempt has been made to access changer X, although this is either already occupied with a different task or is not present at all.

**CHANGER 22:      changer X unexpected error**

A sample changer fault has occurred which cannot be specified more closely. have you entered a sample changer address (see <STATUS>key)? check the auto start settings. Try to remedy the error by switching the instrument off and on again.

**CHANGER 23:      changer 'X' special beaker not defined**

A particular special beaker is required for the method used. Define the appropriate special beaker for the sample rack used (softkeys [Config.] [Sample changer] [Special beaker]) or alter the method (command **Changer**).

**CHANGER 24:      changer 'X' after MOVE\_B no beaker present**

The required special beaker has not been found. The sample changer can be manipulated manually in the HOLD condition. Place the special beaker in the corresponding position and press <HOLD/CONT>.

**CHANGER 25:      changer 'X' wrong rack**

The method used requires a particular sample rack which apparently is currently not placed on the sample changer. The sample changer can be manipulated manually in the HOLD condition. Place the correct rack on the changer and press <HOLD/CONT>.

**CHANGER 27:      changer 'X'; missing sample beaker**

The next sample beaker has not been found. The sample changer can be manipulated manually in the HOLD condition. Place the correct sample beaker in the appropriate position and press <HOLD/CONT>.

**CHANGER 28:      changer 'X'; Pump missing or not configured**

The selected pump is not present or has not been configured. Check the configuration under [Config.] [Sample changer] [Changer 1(2)].

**CHANGER 29: changer 'X' error; Key[Reset]-->MAN CONTROL**

There is a sample changer fault. It is necessary to reset the sample changer. Press the <MAN CONTROL> key and then the softkeys [Sample changer] and [Reset].

**CHANGER 42: missing type def. for rack no. "X"**

A rack has been defined, but the type of rack has not been entered. Enter the correct rack type (e.g. M12-0 for a 12-position Metrohm rack) for the corresponding sample rack.

**CHANGER 43: same code for rack no. "X" and no. "Y"**

Rack codes must be unambiguous. Alter the code of one of the racks mentioned. Note that the code must always coincide with the physical arrangement of the magnet code of the racks.

---

**CONFIG**
**CONFIG 1: "standard file name" too long**

The standard file name entered is too long for the type of file name. Shorten the text to 5 characters.

**CONFIG 2: invalid password**

Access to the access control page is protected by a password. Enter the correct password.

---

**CURVE**
**CURVE 1: too few measuring points**

In order to produce a measuring curve or a calibration curve at least 4 measurements must be recorded.

**CURVE 2: curve display not possible**

Data required for the representation of a curve are not present. Make sure that the measurement time recording function has been switched on if the curve is to be produced on the time axis: see page 135.

**CURVE 3: missing scale parameters for X-axis**
**CURVE 4: missing scale parameters for Y-axis**

All the scale parameters have not been entered.

**CURVE 5: incomplete parameters**

Not all the parameters required for the production of a curve have been entered.

---

**CURVE\_REP**

---

**CURVE\_REP 1: curve printing not possible**

Data required for the printout of a curve are not present. Make sure that the measurement time recording function has been switched on if the curve is to be produced on the time axis: see page 135.

**CURVE\_REP 2: missing scale parameters for X-axis****CURVE\_REP 3: missing scale parameters for Y-axis**

All the scale parameters have not been entered.

---

**DATA CARD**

---

**DATA CARD 1: read/write error**

A fault has occurred on access to the data card. Check whether the card has been inserted correctly and repeat the previous action. If the fault occurs again it may be necessary to reformat the data card.

**DATA CARD 2: card invalid or not available**

The data card has not been recognized. Check whether the card has been inserted correctly and repeat the previous action. If the fault occurs again it may be necessary to reformat the data card.

**DATA CARD 3: battery word not readable, check card battery**

The data card check code cannot be read in. Its battery is probably empty or the card has been affected by external influences. Replace the card battery and/or reformat the card.

**DATA CARD 4: low card battery, change soon**

The card battery should be replaced by a new one as soon as possible as otherwise the stored data could be lost.

**DATA CARD 5: low level read/write error**

A serious fault has occurred on accessing a file on the data card. Please contact the service department of your local Metrohm agency.

**DATA CARD 6: invalid file descriptor**

The data card check code is not valid. The card has probably been affected by external influences. It should be reformatted.

**DATA CARD 8: file name already exists**

Rename the file mentioned.

**DATA CARD 9: file name not found**

The file mentioned cannot be accessed. Either the file name has not been entered correctly or the data card has been removed from the instrument after the file list has been read in.

**DATA CARD 14: data card already full**

There is not sufficient space on the data card. Delete those files on the card which are no longer required or use a different data card.

**DATA CARD 16: file is locked**

The file mentioned is protected against overwriting or deletion. It must first be released in the file manager with the softkey [Lock/Unlock].

**DATA CARD 17: unexpected end of file**

The selected file is damaged and therefore cannot be loaded. Try to delete the file.

**DATA CARD 18: data card is write protected**

The data card is protected against overwriting or deletion. The protection can be removed at any time. Consult the leaflet accompanying the card.

**DATA CARD 19: card is read only technology**

The type of card used is a so-called flash-card, which the 796 Titroprocessor can only read; it cannot be written on.

**DATA CARD 20: card not formatted**

Before use in the 796 Titroprocessor the data card must first be initialized in its special format. Press the [Change storage] softkey in the file manager, select 'Data card' and follow the instructions on the screen.

**DATA CARD 21: unused data blocks marked as in use**

The organization of the memory blocks on the data card is faulty. If the card cannot be read in the file manager it must be reformatted.

**DATA CARD 22: undefined error**

A fault has occurred which cannot be specified more closely. Please contact the service department of your local Metrohm agency.

**DATA CARD 23: low card battery**

Replace the data card battery.

---

**DETSTORE**

---

**DETSTORE 1: Corrupt memory detected. Continue anyway ?**

The last determination was not properly concluded, probably because the instrument was switched off during a storage process. In order to clean up the resulting memory conflict the error message must be answered with <n> to clear the working memory of all the files it contains or to initialize other memory areas. If the error message is answered with <y> then the Titroprocessor will start without taking any further measures. However, it must be expected that the instrument may behave in an irregular manner because of the memory conflict mentioned above.

**DETSTORE 2: Determination X.Y corrupt. Clear working memory?**

The last determination was not properly concluded, probably because the instrument was switched off. In order to clean up the resulting memory conflict the error message must be answered with <y> to clear the working memory of all the files it contains. If <n> is pressed then only the faulty determination will be deleted.

**DETSTORE 3: Do you want to clear working memory ?**

Because of memory conflicts (see previous error messages) it is recommended that the working memory is cleared. This will be carried out if the error message is answered with <y>. All data in the working memory will be lost. If <n> is pressed then a comprehensive memory clean-up can be undertaken.

**DETSTORE 4: Storage initializing recommended. Initialize partially?**

In order to remedy memory conflicts (see previous error messages) the whole operator memory area (current methods, working memory, internal memory) can be cleared by pressing <y>. The GLP data remain unaffected. Answering with <n> means that a total initialization of the complete memory can be carried out (see next error message).

**DETSTORE 5: Total initialisation: restart and press <space>**

In order to remedy existing memory conflicts which could influence the functioning of the Titroprocessor it may be necessary to carry out a total initialization of the instrument. After pressing the <ENTER> key the system is stopped. Total initialization of the Titroprocessor is triggered by switching it off and then on again with pressed-down space bar: this deletes all data stored in the instrument (determinations, methods, GLP data, configuration settings, etc.) and returns it to the standard settings. Switching on without pressing down the space bar produces a normal start-up; no data are deleted or altered.

**DETSTORE 6: lock impossible, quit dialog page**

Running or reloading a method cannot be implemented as long as the currently opened dialog page has not been closed. Close it and then press the <HOLD/CONT> key to run the method.

---

**DIAGNOSIS**

---

If error messages occur during diagnosis please contact the service department of your local Metrohm agency.

---

**DIALOG**

---

**DIALOG 1:           method name changed, unable to store field cont.**

A new method has been loaded and a determination started in the background during editing. This means that the edited field content cannot be stored with the previous determination.

**DIALOG 2:           method load disabled: quit method editor**

The Titroprocessor cannot load a method automatically as defined in the sample silo, as alterations to the current method are being made in the method editor at the same time. Close the method editor.

**DIALOG 3 + 4:       RS232 interface busy**

An attempt has been made to access a RS232 interface while this is occupied with a different task. Wait until the interface is free.

**DIALOG 6:           command list full**

The maximum number of commands in a method has been reached. Delete unnecessary or empty command lines.

**DIALOG 7:           method load impossible while editing**

The Titroprocessor cannot load a method automatically if entry fields relevant to the current determination are being edited at the same time. Stop editing or interrupt the method run with the <HOLD> key.

**DIALOG 8:           abort <a> restarts the Titroprocessor**

The memory organization has been damaged by unexpected actions in such a way that the Titroprocessor must be restarted. The restart is carried out automatically by pressing the <a> key.

**DIALOG 9:           no measured values available**

As no measurements are present for the current determination it is not possible to produce a measurement curve.

**DIALOG 12:          "EMPTY" not possible for 685 Dosimat "XX"**

The EMPTY function is not available for a 685 Dosimat.

**DIALOG 13:          tubing configuration of Dosimat "XX" not found**

The tubing set with the tubing parameters given for dosing drive XX is not present. It may have been deleted. Enter a different tubing set or create a new definition under [Config] - [Tubings].

**DIALOG 14:       incomplete parameters**

Not all the parameters required for the action to be performed have been entered. Check the settings.

**DOSING**

---

**DOSING 1:       lost contact to dosing drive "XX"**

Dosing drive XX is not connected. Switch off the Titroprocessor, connect up the dosing drive and switch on again. Dosing drives are only recognized correctly when the instrument is started up.

**DOSING 2:       already locked "XX"**

Dosing drive XX is currently being used in a method and is not available for manual operations.

**DOSING 4:       dosing drive "XX" not found**

Dosing drive XX is not connected. Switch off the Titroprocessor, connect up the dosing drive and switch on again. Dosing drives are only recognized correctly when the instrument is started up.

**DOSING 5:       dosing drive "XX" overload**

Dosing drive XX is overloaded. Check the buret unit.

**DOSING 7:       dosing drive "XX" not ready**

Dosing drive XX is currently being used for a different task. Wait until it is free again.

**DOSING 8:       check exch. unit on drive "XX"**

Dosing drive XX cannot carry out the required operation as an exchange/dosing unit has not been attached or is not attached correctly.

**DOSING 9:       power limit of drive "XX" reached**

Dosing drive XX is overloaded. Check the buret unit.

**DOSING 10:      command for "XX" not executable**

The selected command is not applicable to XX-type dosing drives.

**DOSING 11:      common access failure YYYY "XX"**

Dosing drive XX does not answer. Check the connections.

**DOSING 12:      Prepare dosing unit(s) !**

Before a sample series can be started the dosing drive involved should be correctly prepared. Press the <MAN CONTROL> key, select the corresponding dosing drive and start the PREP cycle with the [Prepare buret] softkey.

**DOSING 21: XX busy or not corresponding settings**

Dosing drive XX is not answering at the moment. Wait until it is ready again or, if necessary, switch the Titroprocessor off and then on again.

**DOSING 22: XX already locked**

- The dosing drive to be accessed is currently being used by a running determination. Wait until this has been completed.
- A running method is trying to access a dosing drive which is currently occupied with a manual operation. This interrupts the determination ('HOLD'). As soon as the dosing drive involved is again available the determination can be resumed by pressing the <HOLD / CONT> key.

**DOSING 23: XX not present, check dosing drive**

Dosing drive XX is not connected. Switch off the Titroprocessor, connect up the dosing drive and switch on again. Dosing drives are only recognized correctly when the instrument is started up.

**DOSING 24: XX check exchange unit**

The exchange unit or dosing unit of dosing drive XX is not attached or is not attached correctly.

**DOSING 25: XX not corr. settings for DEVICES and METHOD**

In the running method entries for the reagent are laid down which do not coincide with the current entries on the dialog page 'Devices & Manual Control'. Check whether the correct reagent is being used with the selected dosing drive. Bring the entries up to date if necessary (<MAN CONTROL> key). The name of the reagent can be selected from a suggestion list (with space bar or [Select] softkey). If the comparison of the reagent names is not required this can be switched off by completely deleting the entry.

**DOSING 26: XX no power**

Dosing drive XX is overloaded. Check the buret unit.

**DOSING 27: XX not ready, probably filling**

The dosing drive is currently occupied. Wait until it is free again.

**DOSING 28: XX unexpected error, code XXXX**

A fault has occurred which cannot be specified more closely. Check the dosing drive and the dosing drive connections. If the fault cannot be remedied please contact the service department of your local Metrohm agency and tell them the error code.

**DOSING 29: XX no tubing set**

No buret unit with tubing parameters has been entered for a PREP or EMPTY command. Check the method.

---

**FILE**

---

**FILE 1:           wrong file type "XXXXXXXX"**

The selected file does not correspond to the type of file required.

**FILE 2:           not enough memory "XXXXXXXX"**

The selected memory area is full. Delete files which are no longer required and try again to save.

**FILE 3:           data inconsistent "XXXXXXXX"**

The determination file has been damaged. Delete it.

**FILE 5:           verification of checksum failed "XXXXXXXX"**

The file mentioned is damaged. Delete it.

**FILE 6:           incompatible version of "XXXXXXXX"**

The method mentioned was created with a different program version of the 796 Titroprocessor and cannot be used on this instrument.

**FILE 7:           checksum failed "XXXXXXXX"**

The file mentioned is damaged. Delete it.

**FILE 8:           can not delete current det. "XXXXXXXX"**

An attempt has been made to delete the current actual determination from the working memory. If as much working memory space as possible must be made available for a series of samples then initialize the statistics function. On the main page enter 'ini'=initialize under statistics.

---

**FORMULA**

---

**FORMULA 1:       formula list is full**

No more formulas can be entered in the table.

**FORMULA 2...11 : formula X:**

Syntax error in the calculation formula. Correct the formula.

**FORMULA 24...30: XXXXXXXX:**

Invalid values have occurred during the calculation of a formula. The result is incorrect. Check the corresponding calculation formula and try using the TST() function to replace a possibly invalid value in the calculation with a different value, see page 122ff.

---

**GLP DATA**

---

**GLP DATA 1: service interval expired, servicing required**

The set service interval has expired, see page 280. It is time for the instrument to be serviced. Please contact the service department of your local Metrohm agency.

**GLP DATA 2: out of validation limits, method XXXXXXXX**

The set limits for the validation have not been met, see page 281. Check the whole system (dosing drive, balance, etc.) and repeat the validation.

**GLP DATA 3: validation interval expired, method XXXXXXXX**

The preset interval for the validation method mentioned has expired. A new validation should be carried out.

**GLP DATA 4: sensor test: sensor XXXXXXXX out of limits**

The sensor mentioned does not meet the limits specified in the sensor test. Regenerate the sensor according to the manufacturer's instructions and repeat the test.

**GLP DATA 5: no GLP results in statistics**

No statistics equation has been found in the validation method, so that no GLP evaluation is possible. Alter the type of calculation formula to 'stat.'.

**GLP DATA 6: sensor test interval expired, sensor XXXXXXXX**

The laid down test interval of the sensor mentioned has expired. Carry out a sensor test.

**GLP DATA 7: parameters changed! Reject results?**

The GLP limits of a valid validation have been altered. This is not allowed. Carry out a new validation or reject the alteration with the <n> key.

---

**KEYBOARD**

---

**KEYBOARD 1: hardware defect**

Keyboard problems have been determined which indicate a hardware fault. Please contact the service department of your local Metrohm agency.

**KEYBOARD 2 ... 13: keyboard ...**

Keyboard problems have been determined which indicate a hardware fault. Please contact the service department of your local Metrohm agency and tell them the error number and the error message text.

---

**MALLOC**

---

**MALLOC 1: last powerdown left inconsist. status. Continue anyway?**

Switching off the instrument has caused memory conflicts. It is recommended that the error message is answered with <n> and that a part initialization of the user memory area is carried out, see error message DETSTORE 4, page 238. If the error message is answered with <y> the Titroprocessor starts up without taking any further measures. However, it must be expected that the instrument may behave in an irregular manner because of the memory conflict mentioned above.

**MALLOC 3: out of user memory**

The working memory and the internal memory cannot accept any more data. Delete determinations or methods which are no longer required from these memories.

**MALLOC 4: out of system memory**

The internal system memory is overloaded by printing jobs or other internal functions. Terminate any printing jobs with the key combination <Shift> <PRINT>. Avoid several large printing jobs in sequence.

**MALLOC 5: reallocation of user memory failed**

A serious fault has occurred during internal memory operations. Switch the instrument off and then on again. If this error message appears again then a total initialization of the whole memory is necessary which will delete all data in the Titroprocessor. In order to trigger this switch the instrument on with the space bar pressed down.

**MALLOC 6: reallocation of system memory failed**

A serious fault has occurred during internal memory operations. Switch the instrument off and then on again. If this error message appears again then a total initialization of the whole memory is necessary which will delete all data in the Titroprocessor. In order to trigger this switch the instrument on with the space bar pressed down.

---

**MAN\_CAL**

---

**MAN\_CAL 1: invalid measured value**

The measured value is not valid. Check the sensor and the buffer solution.

**MAN\_CAL 2: temperature value invalid**

The value given by the temperature sensor is invalid. Check it.

**MAN\_CAL 3: value not in buffer table**

A buffer value has been found which does not match any buffer solution of the given manufacturer or type. Check the buffer parameters and the buffer solution.

- MN\_CAL 4: buffer out of tolerance**
- The buffer value found is outside the tolerance range ( $\pm 30$  mV) of the standard buffer given. Check sensor and buffer solution.
- MN\_CAL 5: same buffer**
- The same buffer value has been found twice in succession. The buffer solution has probably not been changed.
- MN\_CAL 6: temperature out of range**
- During temperature measurement an invalid value has been found. Check that the temperature sensor is functioning properly.
- MN\_CAL 7: temperature out of tolerance**
- For a correct calibration all buffer solutions in a series must have approximately similar temperatures. A temperature has been found which is outside the tolerated scatter range of 2°C.
- MN\_CAL 8: meas. value overrange**
- A potential  $> 2000$  mV has been measured. Check the sensor.
- MN\_CAL 9: meas. value underrange**
- A potential  $< -2000$  mV has been measured. Check the sensor.
- MN\_CAL 12: max. number of buffers reached**
- The buffer list is full. No further buffers can be measured.
- MN\_CAL 13: check buffer type and list**
- The newly entered buffer type does not match the corresponding buffer in the table. Correct the buffer type or delete the whole calibration.
- MN\_CAL 14: missing temperature sensor, interface 'X'**
- The necessary temperature sensor has not been connected.
- MN\_CAL 15: invalid standard buffer value**
- The measured buffer value cannot be allocated to any standard buffer of the given manufacturer or type.

---

**MEAS/CAL**

---

**MEAS/CAL 1: cycle time too short**

The selected measuring interval is shorter than the waiting time of the drift-controlled individual measurements. This can lead to irregular cycle times for the series of measurements. If necessary correct the waiting time or switch off the measurement drift control.

**MEAS/CAL 2: measured value out of buffer tolerance**

The measured value of the buffer solution does not correspond with the nominal buffer value. Check the sensor and buffer solution.

**MEAS/CAL 3: same buffer (?)**

The same buffer value has been found twice in succession. The buffer solution has probably not been changed.

**MEAS/CAL 4: buffer temperature out of tolerance**

For a correct calibration all buffer solutions in a series must have approximately similar temperatures. A temperature has been found which is outside the tolerated scatter range of 2°C.

**MEAS/CAL 5: invalid measuring value**

An invalid measuring value has been found. Check the sensor.

**MEAS/CAL 6: irregular calibration, save anyway?**

A fault has occurred during the measurement of a buffer solution. Press <n> to accept the buffer value anyway, or <a> to interrupt the calibration.

**MEAS/CAL 7: irregular calibration, buffer will be ignored**

A fault which cannot be more closely specified has occurred during the measurement of a buffer solution. The buffer will be ignored for the calibration.

---

**MEAS.INP.**

---

**MEAS.INP. 1: meas.input 'X' busy, press [Start / Stop]**

It is not possible to alter the measuring mode while a measurement is taking place. The measurement should first be stopped.

**MEAS.INP. 2: meas.input 'X' already locked**

A manual measurement cannot be made if the selected measuring input or sensor is occupied with a running method.

**MEAS.INP. 3: meas.input 'X' not found**

The selected measuring input is not built into the instrument.

**MEAS. INP. 4: meas. input 'X': missing A/D-Converter calib. data**

Calibration data for measuring group X have been deleted as a result of external influences. Please contact the service department of your local Metrohm agency.

**MEAS. INP. 5: meas. input 'X', missing temp. sensor**

No temperature sensor has been connected to measuring input X.

**MEAS. INP. 6: meas. input 'X', unable to start, measuring error**
**MEAS. INP. 7: meas. input 'X' mode:XXXX, value read error YYYY**
**MEAS. INP. 8: meas. input 'X' not accessible**

These are serious hardware faults of measuring group X. Please contact the service department of your local Metrohm agency.

---

**METHOD**

---

**METHDD 1: missing END command in last line XX**

No END command has been defined in the method, although this is a precondition for concluding a determination.

**METHDD 2: line XX: too many DET, MET, ..., MEAS, CAL modes**

A maximum of only 5 titration or measurement modes are allowed in a method, as there must be sufficient system memory space available for carrying out the method.

**METHDD 3: line XX: more than one CAL\* in (CAL .. )CAL**

Only one CAL\* command can be defined in a calibration sequence. Several calibration sequences in one method are allowed.

**METHDD 4: nested (OMOVE sequence, see line XX**

The start sequence (OMOVE of the method has been incorrectly programmed. A sequence must always be concluded with the corresponding command, in this case OMOVE), before another sequence can be started.

**METHDD 5: nested (CMOVE sequence, see line XX**

The closing sequence (CMOVE of the method has been incorrectly programmed. A sequence must always be concluded with the corresponding command, in this case CMOVE), before another sequence can be started.

**METHDD 7: nesting error, see line XX**

Non-permissible nests of command sequences have been programmed in the method. A sequence must always be concluded with the corresponding command before another sequence can be started.

**METHOD 8: incomplete (OMOVE sequence, see line XX)**

The start sequence (OMOVE of the method has not been completely defined. A sequence must always be concluded with the corresponding command, in this case OMOVE).

**METHOD 9: incomplete (CMOVE sequence, see line XX)**

The closing sequence (CMOVE of the method has not been completely defined. A sequence must always be concluded with the corresponding command, in this case CMOVE).

**METHOD 10: incomplete (CAL sequence, see line XX)**

The calibration sequence (CAL of the current method has not been completely defined. A sequence must always be concluded with the corresponding command, in this case CAL).

**METHOD 11: incomplete (CASE sequence, see line XX)****METHOD 12: incomplete (CASE sequence, see line XX)**

The condition sequence (CASE of the current method has not been completely defined. A sequence must always be concluded with the corresponding command, in this case CASE).

**METHOD 13: incorrect OMOVE / CMOVE structure, see line XX**

Non-permissible nests of command sequences have been programmed in the method. A sequence must always be concluded with the corresponding command before another sequence can be started.

**METHOD 14: line XX: illegal nesting, check method!**

Non-permissible nests of command sequences have been programmed in the method. A sequence must always be concluded with the corresponding command before another sequence can be started.

**MONITORING****MONITORING 1: no more samples in silo**

There are no further samples in the silo. The silo pointer is located at the bottom line. Set the '<-- Out pointer' again. Silo 'rst' on the main page or in the <Status> window sets the silo pointer to the first line.

**MONITORING 2: missing method XXXXXXXX**

A method given in the silo cannot be loaded because it is stored neither in the internal memory nor on the data card.

**MONITORING 3: check method XXXXXXXX**

The given method is faulty and cannot be carried out.

**MONITORING 4: auto save aborted; XXX bytes needed**

There is too little space available in the target memory. Delete files which are no longer required.

**MONITORING 7: new method while statistics ON**

A new method has been loaded or the existing method has been altered while statistics is switched on. During the statistical calculation this could lead to results with the same name which have been produced in different ways being calculated with each other.

**MONITORING 8: working memory full; delete determinations**

There is not enough working memory space available for the next determination. Delete determinations from the working memory (in the file manager). Also reduce the set value for the statistics counter, if this is necessary. This value lays down how many determinations are to be held in the working memory before the working memory is cleared (during the next determination).

**MONITORING 10: method autoload disabled: quit method editor**

While alterations are being made in the method editor it is not possible to load a method automatically, as can be defined for a sample series in the sample silo. Close the method window with <QUIT> in order to allow the sample series to proceed.

**MONITORING 11: GLP data not saved, irregular termination**

A GLP validation has not been concluded properly.

**MONITORING 12: check GLP data**

The validation interval for a validation method has expired. Carry out a new validation.

**MONITORING 13: Do you want to reset all statistics data?**

Query before resetting the statistics. The working memory will be cleared.

**MONITORING 14: method line XX : no condition!**

The method contains a CASE or EXIT command without any condition. Check the method line 'xx'.

**MONITORING 15: Impossible to execute "SHOW" while editing**

Because of a SHOW command in the current method a particular dialog page is to be shown; this is not possible while an entry field is being edited. Close the editing mode. The required page will be shown after the next SHOW command.

---

**PRINTER**

---

**PRINTER 1: printer off-line or defect**

The printer does not answer. Press the on-line key on the printer. If necessary switch the printer off and on again. If it still does not answer, subject it to a function test as described in the printer manual.

**PRINTER 2: not reading data**

The printer is not accepting any data. Is the correct cable being used? Is the cable damaged? Has the correct type of printer been defined? If necessary switch both instruments off and on again. If it still does not answer, subject it to a function test as described in the printer manual.

**PRINTER 3: not ready**

The printer is currently occupied. Wait until it is ready or switch it off and on again if this is necessary.

**PRINTER 4: interface, DATA VALID not set**  
**PRINTER 5: interface, data lost**

Data communication with the printer is disturbed. Is the correct cable being used? Is the cable damaged? Has the correct type of printer been defined? If necessary switch the printer off and on again.

**PRINTER 6: no paper! Load paper, please!**

There is no paper in the printer. Load paper and press again.

**PRINTER 7: unexpected error**

A fault has occurred which cannot be specified more closely. Is the correct cable being used? Is the cable damaged? Has the correct type of printer been defined? If necessary switch the printer off and on again. If the fault reoccurs please contact the service department of your local Metrohm agency.

---

**RECALC**

---

**RECALC 1: overwrite common variable XX ?**

During the recalculation of a determination the currently valid Common Variable XX is to be overwritten. If this is required the message must be confirmed with <r>.

---

**RECOGN**

---

**RECOGN 3: equal values for general window settings**

Different values must be entered for the limits of the general EP recognition areas.

**RECOGN 4:**            **enter value for EP-window "X" from ..**  
**RECOGN 5:**            **enter value for EP-window "X" ... to**  
**RECOGN 6:**            **equal limits for EP-window "X"**

Different values must be entered for the limits in EP window XX

**RECOGN 7:**            **EP-window "X" and EP-window "Y" overlapping**

Different EP windows must not overlap. Correct the values for the limits.

**RECOGN 8:**            **EP-window "X" out of general limits**

Correct the limits for EP window X, so that the EP window lies completely within the general area or correct the general limits accordingly.

## REPORTS

---

**REPORTS 1:**            **no printer connected**

Either no external printer has been connected or the internal printer has not been enabled. Check the configuration of the interface, see page 44ff.

**REPORTS 2:**            **interface configured as COMM and printer**

An RS232 interface has been defined as the printer interface and also as the communication interface. This can cause problems during data transfer. Connect one of the instruments to the second RS232 interface.

**REPORTS 3:**            **no COMM interface configured**

For the required action the RS232 interface which is to be used for data transfer must be defined as the communication interface. See page 44ff.

**REPORTS 4:**            **too many variables. Output aborted**

There are too many printer data to be printed out. The required reports can be produced individually via the <PRINT> key.

## RS232

---

**RS232 1:**            **interface X possibly defect**

Problems have been found with RS232 interface X which indicate a hardware fault. Please contact the service department of your local Metrohm agency.

**RS232 2 ... 13: interface X: ...**

The Titroprocessor cannot establish a stable, serial connection via RS232 interface X. Check whether the transfer parameters of the Titroprocessor and those of the connected instrument are identical. Initialize the interface again.

Is an instrument actually connected? Is the correct cable being used?

For connection problems with external instruments please obtain advice from the service department of your local Metrohm agency. Mention the fault number and the error message text.

**RS232 14: interface X: Busy, remote keyb. mode not possible**

The RS232 interface is currently occupied. Wait until the current task has been completed and then alter the settings.

**RS232 15: interface X: unexpected error**

A fault has occurred which cannot be specified more closely. Please contact the service department of your local Metrohm agency.

**RS232 16: interface X, switch on the receive mode**

The selected function requires the data receive mode of interface X. Switch it on under [Config.] - [Interfaces].

**RS232 17: keySEND mode not possible with peripheral devices**

The 'keySEND' mode is switched on and transfers all key actions via the communication interface. This can affect the functioning of any printer, balance or other instrument connected to this interface. If the 'keySEND' function is required then a separate interface should be used for it.

**RS232 18: interface X, SCAN\_RS not possible with keyCTRL mode**

When the key simulation mode keyCTRL is switched on, no SCAN command can be carried out via the same interface. If the <c> key (for continue) is pressed, the procedure will be resumed with the next command. With <a> (for abort) the method is interrupted.

---

## SAMPLE DATA

**SAMPLE DATA 1: no current sample size**

No sample size has been entered. Enter a sample size on the results page (Softkey [Sample data]) and recalculate the determination (Softkeys [ > > > > ] and [Recalculate]).

---

## SAMPLE SILO

**SAMPLE SILO 1: sample silo full**

**SAMPLE SILO 2: too few empty lines in the sample silo**

No further lines can be created in the sample silo. Lines without entries (gray background) are regarded as being reserved. Delete any lines not required. If necessary, a sample silo which is full can be stored and the sample data it contains can be loaded later with the complete sample silo.

---

**SCAN+CTRL**

---

**SCAN+CTRL 1: Remote interface X not present**

The selected 'Remote' interface has not been installed or is not able to function.

---

**STATIST**

---

**STATIST 9: determ running, reset not possible**

The statistics cannot be reset while a determination is being carried out, as the working memory would be completely cleared. This would also affect the determination being carried out.

---

**STORAGE**

---

**STORAGE 1: file is locked**

The file mentioned is protected against deletion or overwriting. The protection can be removed in the file manager with the function [Un/Lock file].

**STORAGE 2: file not found**

A file with the file name mentioned cannot be found in the selected memory area. Check whether the file name has been entered correctly.

**STORAGE 5: inadmissible destination for access control files**

Access control files cannot be loaded into the working memory directly. They are loaded under [Config.] [Access control] [File].

**STORAGE 6: Inadmissible destination for configuration files**

Configuration files cannot be loaded into the working memory directly. They are loaded under [Config.] [File].

**STORAGE 7: Inadmissible destination for rack files**

Rack files cannot be loaded into the working memory directly. They are loaded under [Config.] [Sample changer] [Rack File].

**STORAGE 8: invalid determination**

The determination file is damaged and can no longer be read. Delete it.

**STORAGE 9: switch on the data "Receive mode"**

For the required action the data receive mode of the RS232 interface must be switched on. This can be carried out under [Config.] [Interfaces].

**STORAGE 10: terminate "KeyCTRL mode" first**

For the required action the key simulation mode 'keyCTRL' of the RS232 interface must be switched off. This can be carried out under [Config.] [Interfaces].

**STORAGE 11: "RS 232 Interface" still active**

There is still a connection to an external instrument via the RS232 interface. This data communication should first be terminated.

**STORAGE 12: invalid file name**

The file name is not in accordance with the conventions for the naming of files, see page 74.

**STORAGE 13: RS232 interface, check settings**

The interface parameters do not meet the requirements of the selected action. Correct the settings under [Config.] [Interfaces].

**STORAGE 14: copy process aborted**

A copying process could not be completed owing to an operator action. The selected file(s) have not been copied.

**STORAGE 15: unexpected file block size**  
**STORAGE 16: memory block size violation**

Faults have occurred during file transfer. Check the interface parameters of the PC software.

**STORAGE 17: undefined error**

A fault has occurred which cannot be specified more closely. Please contact the service department of your local Metrohm agency.

**STORAGE 18: invalid type of file**

The selected file cannot be stored in the given memory area as it does not meet the specified type.

**STORAGE 19: invalid file**

The selected file is damaged or of an unsuitable type.

**STORAGE 20: remove balance from interface X**

No balance can be active on the same interface during file transfer. Switch it off or connect it to a different interface.

---

**SYSTEM**

---

**SYSTEM 1: Execution not possible while measuring**

The selected function cannot be carried out while a method is running. Wait until the method has ended.

**SYSTEM 2: Measuring start inhibited at this state**

It is not possible to start a method while alterations are being carried out in the method editor at the same time. Close the method editor.

---

**TITRATION**

---

**TITRATION 1: dosing drive not responding**

The connection to the selected dosing drive has been interrupted during the titration. Stop the determination, switch off the Titroprocessor and reconnect the dosing drive. Switch the Titroprocessor on again.

**TITRATION 2: A/D converter error**

The analog/digital converter of the sensor interface is faulty. Please contact the service department of your local Metrohm agency.

**TITRATION 3: measuring point list overflow**

More than 1000 measuring points have been recorded. An evaluation of the further measuring points is not possible. Correct the control parameters of the titration, see page 137 (DET), 145 (MET), 152 (SET), 159 (KFT), or 176 (MEAS).

**TITRATION 4: end-point list overflow**

More than 9 equivalence points have been found. Further equivalence points cannot be evaluated. Optimize the recognition parameters and, if necessary, the control parameters of the titration, see page 139.

**TITRATION 5: max. number of measuring points reached**

More than 1000 measuring points have been recorded. An evaluation of the further measuring points is not possible. Correct the control parameters of the titration, see page 137 (DET), 145 (MET), 152 (SET), 159 (KFT), or 176 (MEAS).

**TITRATION 6: end-point already reached**

The set target end-point has already been reached at the start of the titration. An attempt may have been made to retitrate a sample which has already been titrated.

**TITRATION 7: no end-point set**

No set target end-point has been entered for an end-point titration (SET, KFT, SEC, KFC). Add the set target end-point to the method.

**TITRATION 8: titration start while not cond. ready**

A titration has been started although the previous conditioning mode was not finished correctly. The started titration may produce an incorrect result.

**TITRATION 9: no current sample size**

No sample size has been entered. Enter a sample size on the results page (Softkey [Sample data]) and allow the determination to be recalculated (Softkeys [ > > >> ] and [Recalc one]).

**TITRATION 10: dosing drive not responding**

The connection to the selected dosing drive has been interrupted during the titration. Stop the determination, switch off the Titroprocessor and reconnect the dosing drive. Switch the Titroprocessor on again.

**TITRATION 11: ADD\_R volume too high, corrected to 1000 mL**

The calculation of the dosing volume for the ADD\_R command from the factor and sample size has resulted in too large a value. The largest possible volume is 1000 mL. If the error message is confirmed with <c> the dosing volume will be corrected to 1000 mL.

---

**TUBINGS**

---

**TUBINGS 1: same name for type no. "X" and no. "Y"**

At least two tubing sets have been given the same type name. The names must be unambiguous.

**TUBINGS 2: type no. "X" is not complete**

The parameters for the definition of buret unit no. X have not been completely defined.

## 12.2 Remediating storage errors

In some circumstances (voltage fluctuations in the power supply, etc.) it may be necessary to clear the working memory or to re-initialize the complete Titroprocessor memory.

### 12.2.1 Titroprocessor new start

---

A new start of the 796 Titroprocessor is triggered by the key combination <↑><ALT><DEL>. This corresponds to the instrument switch-on process ('Power on').

### 12.2.2 RAM initialization (original initialization)

---

RAM initialization deletes all data in the 796 Titroprocessor and resets the configuration data to the factory settings.



---

**Save your methods and determination data as well as the configuration settings on data cards or a personal computer (see page 37f) before you carry out a RAM initialization!**

---

The RAM initialization is triggered by **holding down the space bar when the instrument is switched on**. Keep the space bar pressed down until the display text appears.

The screen contrast now changes continuously from completely dark to completely bright. Press any key when the text is easily legible. As soon as the start procedure has been completed the main page will be shown and the screen contrast can be finely tuned with the <ALT><↑> and <ALT><↓> keys.

### 12.2.3 Clearing up memory errors in the data memory

---

The data memory areas of the 796 Titroprocessor are checked for data integrity by means of a check-sum testing method.

If a serious memory error occurs during a determination or data storage then this will be recognized the next time that the instrument is switched on and a corresponding error message will be shown. The error can be remedied by a targeted deletion of the affected memory area.

Memory errors can be caused by e.g.:

- Switching off the Titroprocessor while a determination is being carried out.
- Switching off the instrument during storage or loading procedures.
- Removing the data card while it is being accessed by the Titroprocessor.

**Warning:**

**Only switch off the 796 Titroprocessor in the ready condition (\* ready \*), never during a running determination or saving process.**

When the instrument is switched on various error messages can appear. The following message appears if data from one determination only are affected:

**WARN. DETSTORE: Determination x.x corrupt. Clear working memory ?**

In this case the error can be remedied in the following way:

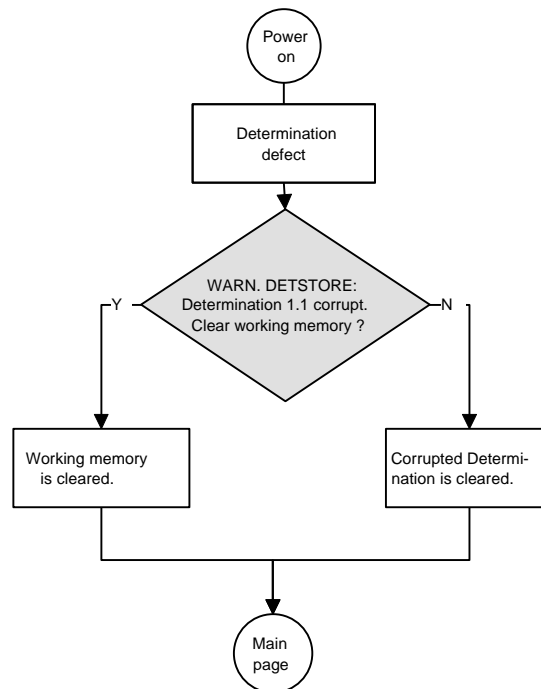

If the query is answered with **<N>** then only the data in the defect determination will be deleted; this is normally sufficient. If the Titroprocessor should then behave irregularly, delete the working memory by initializing the statistics function. Enter **Statistics 'rst'** on the main page.

If a serious memory error occurs the following error message appears:

**WARN. DETSTORE: Corrupt memory detected. continue anyway ?**

This query can be answered with **<Y>**, but the Titroprocessor may then behave irregularly. You have the possibility of saving your data.

If the query is answered with **<N>**, then proceed as follows:

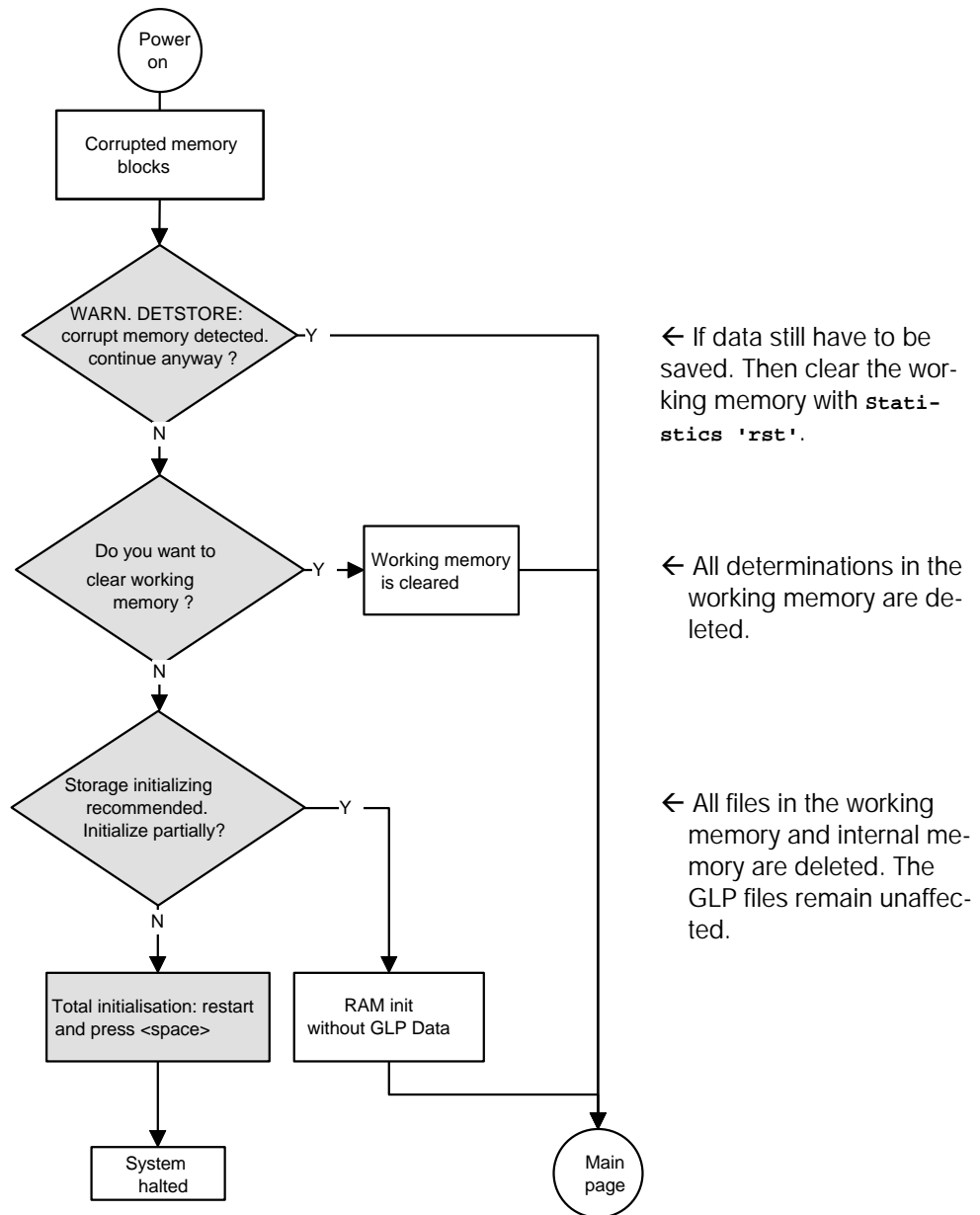

If all queries are answered with **<N>** then the instrument must be switched on again. A complete original initialization can be carried out by keeping the space bar pressed down as the instrument is switched on. If this is not done the same error message will again be displayed.

When a memory error has occurred it is essential to clear the working memory. This can be done on the main page by entering `statistics 'rst'`.



**Save your configuration settings, methods and determination data regularly on data cards or a personal computer!**

## 13 Appendix

---

### 13.1 Diagnosis

#### 13.1.1 General

---

The 796 Titroprocessor is a very precise and dependable instrument. Thanks to its rugged construction, it is highly unlikely that external mechanical or electrical influences will have any adverse effect on its functions.

Although a fault in the instrument can not be excluded with certainty, the possibility is greater that malfunctions are caused by wrong operation or handling, through improper connections and the operation with third-party devices.

Whatever the case, it is always advisable to localise the fault with the diagnostic tests, which can be performed quickly and simply. The customer need call Metrohm service only when the instrument really has a fault. Further, he can use the results of the specific diagnostic function to provide the service engineer with much more precise information.

In the case of inquiries, always quote the serial number on model plate (see *Figure, page 4*), the program version (see configuration, *page 34*) and if applicable the error message.

### Procedure

The diagnostic menu listed in *section 13.1.2* shows all components for which detailed instructions (diagnostic steps) are available for checking the functionality.

In the case of a possible malfunction, we advise you to perform either the corresponding diagnostic step or all diagnostic steps as a routine check on the instrument.

The reactions of the instruments to the instructions must be compared with the descriptions in the diagnostic step. If the instruments do not show the expected reaction ("No" case), the appropriate diagnostic step must be repeated to exclude operating errors. However, it is highly probable that repeated wrong reactions indicate a malfunction.

### Equipment required:

3.496.8510	test plug to check the Remote interface
3.496.8480	test plug to check the RS 232 interface
3.496.8570	test plug to check the Barcode interface
1.767.0010	simulator to check the analog inputs

**13.1.2 Prepare instruments for diagnostic test**

1. Power off.
2. Disconnect all cables at rear, except mains cable.
3. Power on.
4. **<Config. >**
5. **< >> >**  
**>>**
6. **<Service diagn. >** <sup>1)</sup>

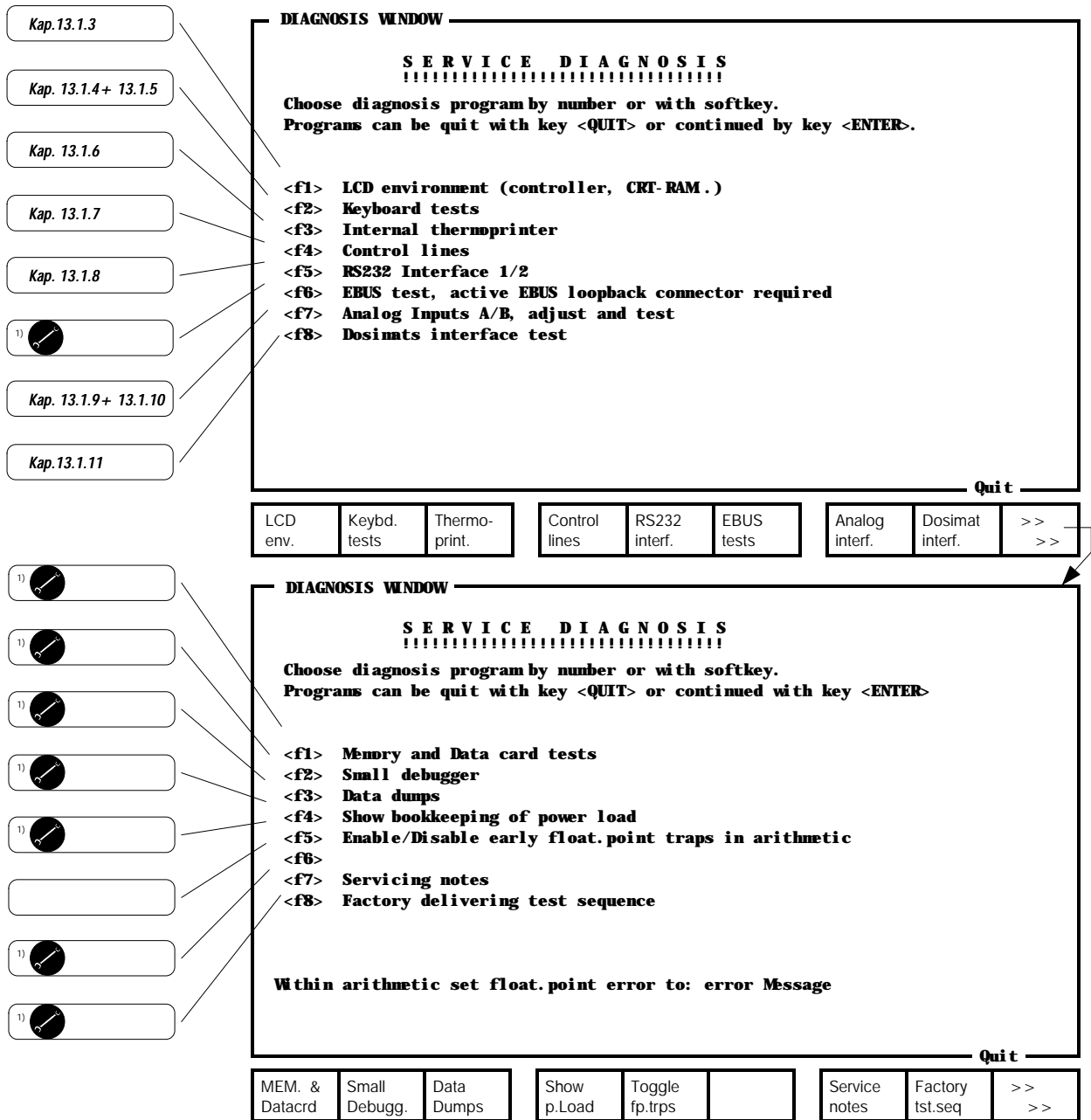

1) This diagnostic step is reserved for the service engineer and therefore is not described further within this document.

### 13.1.3 To check display

---

With this diagnostic step the LCD and its control unit are checked for their functionality.

1. Prepare instrument for diagnostic test (see chap. 13.1.2).
2. **<LCD env. >**
3. **<B. light OFF>**  
 ↳ *The background lighting goes out and so the screen text is only faintly visible.*
4. **<F4>**  
 ↳ *The control voltage for the dot matrix is switched off and so the screen is blank.*
5. **<F1>**  
 ↳ *The background lighting is switched on and so the screen appears pale blue but with no text.*
6. **<F3>**  
 ↳ *The control voltage for the dot matrix is switched on again and so the screen appears in its customary form.*
7. **<LCD RAM test>**  
 ↳ *The entire screen memory is checked for functionality. If a defect is found, an error message appears.*
8. **<Contr. test>**  
 ↳ *The screen controller is checked for functionality. If a defect is found, an error message appears.*
9. **<LCD reset>**  
 ↳ *The screen control system is initialised and so for a short time the whole screen is filled with stars and then goes back to the previous screen text*
10. The test is quit by pressing <QUIT>.

### 13.1.4 To check keyboard

---

With this diagnostic step all keys of the keyboard are checked for their functionality.

1. Prepare instrument for diagnostic test (see chap. 13.1.2).
2. **<Keybd. tests>**
3. **<Bounce test>**
4. Press all keys once.  
 ↳ *The keyboard is shown symbolically on the screen. When a key is pressed, the grey background of that key must disappear. If a key is pressed repeatedly, a beep sounds. The test recognises if a key bounces, and an error message is displayed. The special keys <ALT>, <SHIFT> and <SPACE> feature more than once on the keyboard and the software is unable to recognise which one was pressed. Regardless of which <SPACE> key, for example, is pressed, therefore, the one on the far left disappears first, and so on.*
5. The test is quit by pressing the <QUIT> key twice.

### 13.1.5 To check bar-code reader

---

With this diagnostic step the bar-code reader can be checked for functionality. For this test a special test plug with article number 3.496.8570 is required.

1. Prepare instrument for diagnostic test (see chap. 13.1.2).
2. **<Keybd. tests>**
3. Without switching off the instrument plug in test plug 3.496.8570 to the socket "Barcode".
4. **<Barcode test>**
  - ↳ *The test runs automatically. If a defect is found, an error message appears on the display, otherwise the previous screen page appears.*
5. Without switching off the instrument remove test plug 3.496.8570.
6. The test is quit by pressing <QUIT>.

### 13.1.6 To check the internal thermoprinter

---

With this diagnostic step the internal thermoprinter can be checked for its functionality.

1. Prepare instrument for diagnostic test (see chap. 13.1.2).
2. **<Thermoprint. >**
3. **<St. dely pulse>**
  - ↳ *The test runs automatically. If a defect is found, an error message appears on the display, otherwise the previous screen page appears.*
4. **<Test print>**
  - ↳ *A test printout is printed (see next page).*
    - *Check that printout is complete and sharp.*
    - *The character set (the first five lines) must agree with the sample.*
    - *The topmost and lowermost dots of a line must be clearly printed; especially when verifying K and p.*
    - *The printout must have a total length of 260 mm (tol.: ± 10 mm).*
5. The test is quit by pressing <QUIT>.



---

### 13.1.7 To check Remote interface

---

With this diagnostic step the interface Remote can be checked for its functionality. For this test a special test plug with article number 3.496.8510 is required.

1. Prepare instrument for diagnostic test (see chap. 13.1.2).
2. Without switching off the instrument plug in test plug 3.496.8510 to socket "Remote".
3. **<Control lines>**
  - ↳ *The test runs automatically. If a defect is found, an error message appears on the display, otherwise the previous screen page appears.*
4. Without switching off the instrument remove test plug 3.496.8510.

---

### 13.1.8 To check RS232 interface

---

With this diagnostic step the two interfaces RS232 can be checked for their functionality. For this test a special test plug with article number 3.496.8480 is required.

1. Prepare instrument for diagnostic test (see chap. 13.1.2).
2. **<RS232 interf. >**
3. Without switching off the instrument plug in test plug 3.496.8480 to socket "RS232 Interface 1".
4. **<Loopbck test>**
  - ↳ *The test runs automatically. If a defect is found, an error message appears on the display, otherwise the previous screen page appears.*
5. **<Change Ifc. >**
6. Without switching off the instrument plug in test plug 3.496.8480 to socket "RS232 Interface 2".
7. **<Loopback test>**
  - ↳ *The test runs automatically. If a defect is found, an error message appears on the display, otherwise the previous screen page appears.*
8. Remove test plug 3.496.8480.
9. The test is quit by pressing <QUIT>.

### 13.1.9 To check Analog Interface A

With this diagnostic step the analog inputs of Interface A can be checked for their functionality. For this test the testbox with article number 1.767.0010 is required.

1. Prepare instrument for diagnostic test (see chap. 13.1.2).
2. **<Analog interf.>**  
 ↳ On the screen there appears a window with the choice of selecting between analog interface A or B.
3. With the cursor key, mark the letter A to select analog interface A.
4. **<ENTER>**
5. Connect Simulator to Titroprocessor accord. to Fig. 2.
6. **<All inp measure>**  
 ↳ The measurements are continuously updated and presented as follows.:

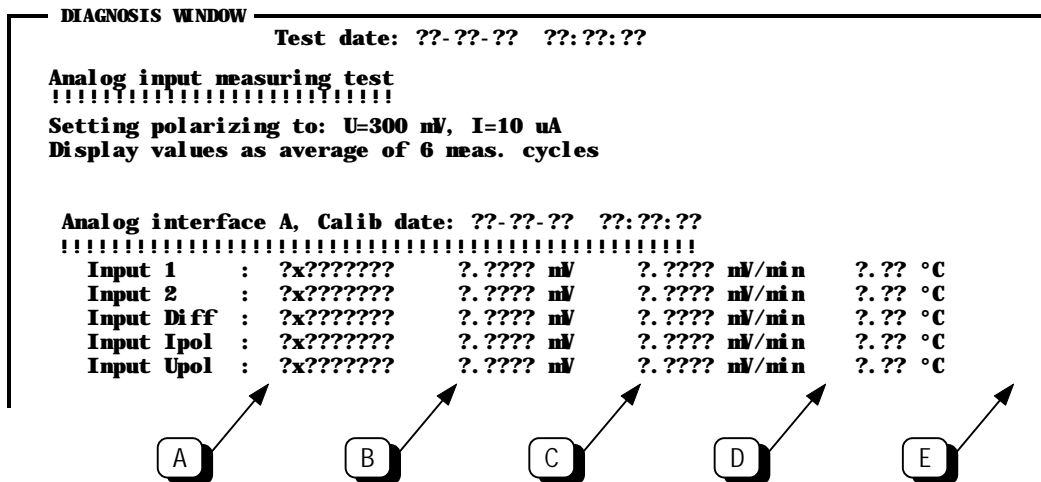

Fig. 1

7. Check the following measuring values:

	column C (see Fig. 1)	column E (see Fig. 1)
<b>Input 1</b> :	+U / direct ± 0.4 mV	Pt100 ± 0.3°C
<b>Input 2</b> :	+U / 1G ± 0.4 mV	
<b>Input Diff</b> :	0 mV ± 4.0 mV	

8. Connect Simulator to Titroprocessor accord. to Fig. 3.

	column C (see Fig. 1)
<b>Input 1</b> :	+U / 1G ± 0.4 mV
<b>Input 2</b> :	+U / direct ± 0.4 mV
<b>Input Diff</b> :	0 mV ± 4.0 mV

9. Connect Simulator to Titroprocessor accord. to Fig. 4.

	column C (see Fig. 1)
<b>Input 1</b> :	-U% / direct ± 0.4 mV

10. Connect Simulator to Titroprocessor accord. to Fig. 5.

	column C (see Fig. 1)
<b>Input 2</b> :	-U% / direct ± 0.4 mV

11. Connect Simulator to Titroprocessor accord. to Fig. 6 and place the cover over the solar cell.

	column C (see Fig. 1)
<b>Input Ipol</b> :	143 mV ± 20 mV
<b>Input Upol</b> :	21 µA ± 3.0 µA

12. <QUIT>

13. Connect Simulator to Titroprocessor accord. to Fig. 7.

14. <All inp measure>

	column E (see Fig. 1)
<b>Input 1</b> :	Pt1000 ± 0.3°C

15. The test is quit by pressing the <QUIT> key twice.

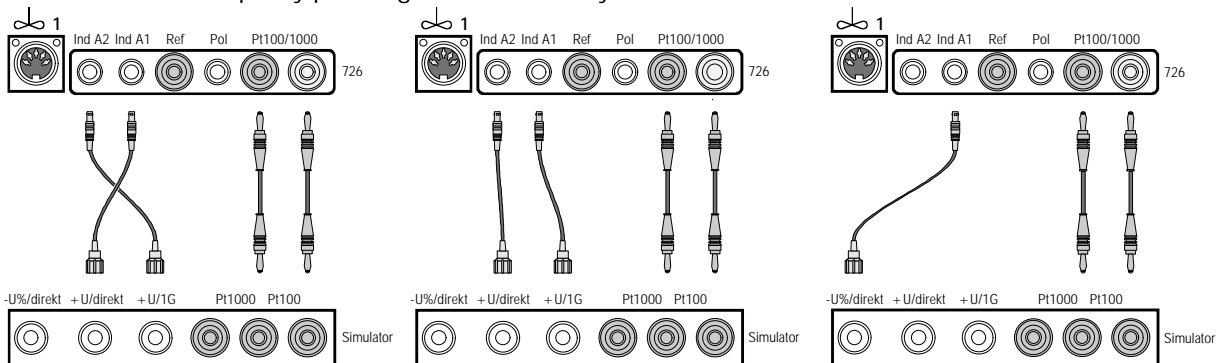

Fig. 2

Fig. 3

Fig. 4

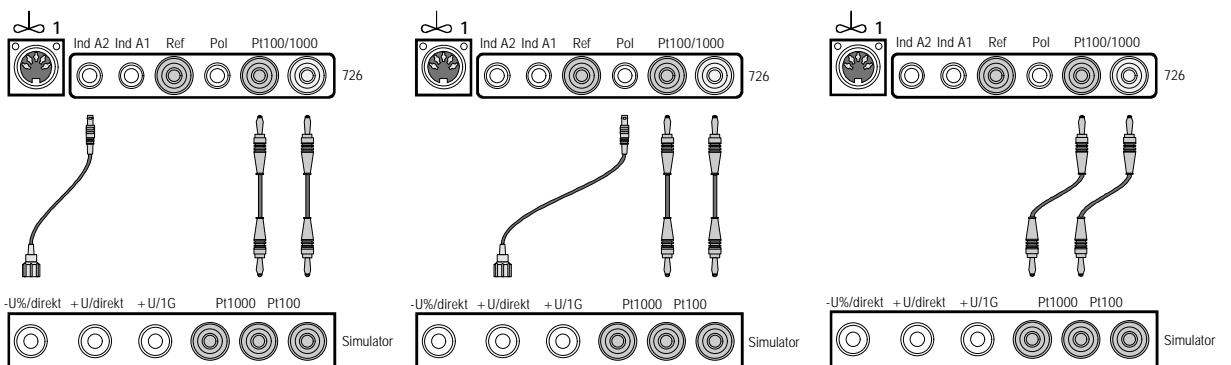

Fig. 5

Fig. 6

Fig. 7

---

**13.1.10 To check Analog Interface B**

---

With this diagnostic step the analog inputs of Interface B can be checked for their functionality. For this test the testbox with article number 1.767.0010 is required.

1. The procedure is exactly the same as described in Section 0, the only difference being that under point 3 one has to mark the letter B instead of letter A.

---

**13.1.11 To check Dosimat Interface**

---

With this diagnostic step the interfaces for the dosing units can be checked for their functionality.

1. Prepare instrument for diagnostic test (see chap. 13.1.2).
2. **<Dosimat interf. >**
3. Without switching the instrument off, connect a 700 Dosino to the interface being tested.
4. **<Activ. triacs>**  
↳ Power supply to the Dosino is activated. This process takes a certain time and is not noticed by the tester.
5. **<Select Dosimat>**
6. With the cursor, select the interface to be tested (e.g. A1)
7. **<ENTER>**
8. **<Regist. wr. /rd. >**  
↳ The test runs automatically. If a defect is found, an error message appears on the display, otherwise the previous screen page appears.
9. **<Funct. test>**  
↳ The test runs automatically. If a defect is found, an error message appears on the display, otherwise the previous screen page appears.
10. Check the other dosing interfaces, following exactly the same procedure as described in points 3...9.
11. The test is quit by pressing **<QUIT>**.

### 13.1.12 Setting the servicing interval

After finishing the the test described above, update the service notes. Press the softkeys [ > > > > ] and [Service notes] on the Service diagnosis page.

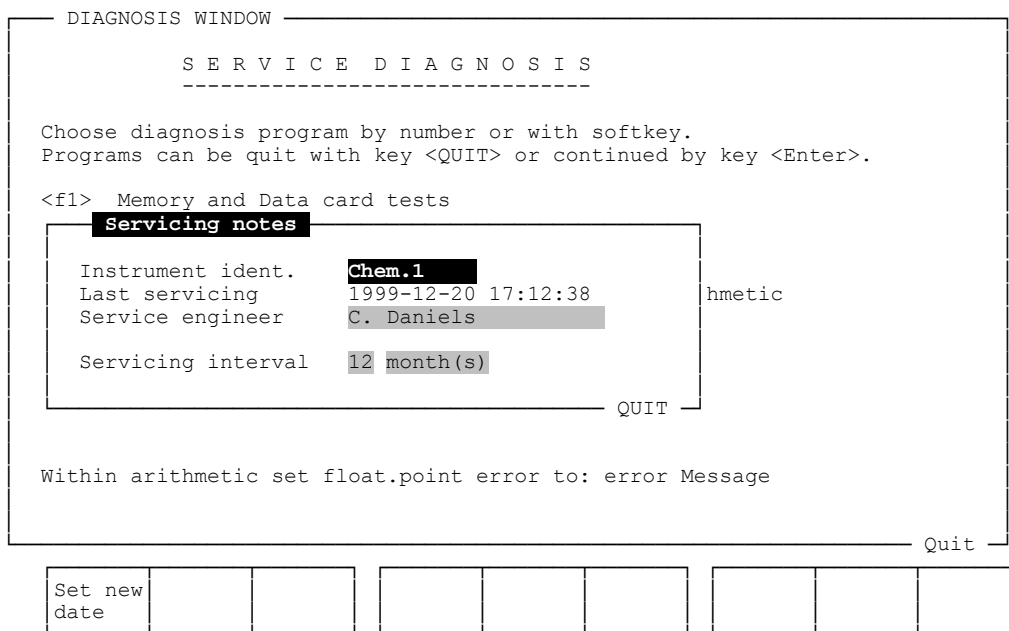

The Instrument identification should be set once and never be changed later on.

Enter your name in the field 'Service engineer'.

The servicing interval should be set to a reasonable value. We recommend to choose 12 to 24 months. After elapsing of the servicing interval, a screen message will appear after start-up of the instrument. The user will be urged to call the servic engineer.

**Most important.** Update the 'last servicing' entry by pressing the [Set new date] softkey.

Press <QUIT> twice to close the diagnosis section of the 796 Titroprocessor.



**by edit** the variable was manually entered or altered

**[method]** the method name stands for the method with which the variable was automatically created

**Flag** Two letters show the status of the variable. The first letter shows the status of the method by which it was produced. The second letter shows the status of the determination which produced it. The flags are:

- o** : original / unaltered method or determination
- m** : modified method or determination
- n** : new / not stored method or manual entry

### Softkeys

---

**[Delete  
ComVar]** deletes the selected common variable.

**[Delete  
all]** deletes all common variables.

### Common variables and determinations

At the start of a determination the global common variables are stored in the determination file. For recalculation of a determination the values which were valid at the time that the determination was carried out will be used. If in the recalculation of a determination a current common variable is to be overwritten then this can be stopped by answering the safety query which may appear with **<a>** (abort).



The modification of the access control files can be called up under [Config.] [Access control] or by pressing the <ALT><A> keys on the main page. The configuration of the access control definitions can be protected by a password.

Password

Password:

QUIT

### 13.3.1 Configuration of the softkey bars

Apart from the keys which can be blocked on the keyboard, the access control window lists all softkey bars of the main dialog pages. Use the cursor keys to select the various softkeys. Each listed softkey can be defined as 'open' (visible) or 'hide' (hidden).



**If the softkeys on the main page of the Titroprocessor 796 are blocked then this means that all the corresponding dialog pages and their functions are no longer accessible.**

Access control: NEW.acf

Hardkeys: GLP      open      Method      open      Password: -  
                  Man. Ctrl   open      Sample      open

Main page:

Config.	Load method	File manager	Edit method	Show curves	Results	Sample silo	Devices ManCtrl	Common vars
<span style="background-color: gray;">open</span>	<span style="background-color: gray;">open</span>	<span style="background-color: gray;">open</span>	<span style="background-color: gray;">open</span>	<span style="background-color: gray;">open</span>	<span style="background-color: gray;">open</span>	<span style="background-color: gray;">open</span>	<span style="background-color: gray;">open</span>	<span style="background-color: gray;">open</span>

GLP:

		Delete method	Define method	Extend. info	Start valid		Sample silo	Sensors
<span style="background-color: gray;">open</span>	<span style="background-color: gray;">open</span>	<span style="background-color: gray;">open</span>	<span style="background-color: gray;">open</span>	<span style="background-color: gray;">open</span>	<span style="background-color: gray;">open</span>	<span style="background-color: gray;">open</span>	<span style="background-color: gray;">open</span>	<span style="background-color: gray;">open</span>

GLP: Sensors

Limits			Extend. Info		Delete sensor			Sensor test
<span style="background-color: gray;">open</span>	<span style="background-color: gray;">open</span>	<span style="background-color: gray;">open</span>	<span style="background-color: gray;">open</span>	<span style="background-color: gray;">open</span>	<span style="background-color: gray;">open</span>	<span style="background-color: gray;">open</span>	<span style="background-color: gray;">open</span>	<span style="background-color: gray;">open</span>

QUIT

	File		Change passwd.	Status defin.				Set all open
--	------	--	----------------	---------------	--	--	--	--------------

### Softkeys

<b>[File]</b>	opens the file dialog window for storing or loading an access control file (*.acf)
<b>[Change passwd.]</b>	opens the dialog window for entering a new password.
<b>[Status defin.]</b>	opens the dialog window for modifying the status definitions.
<b>[Set all open]</b>	places all settings for keys and softkeys to 'open'.

### 13.3.2 Status definitions

The **[Status defin.]** softkey opens the dialog page where the status definitions can be modified, see also page 82.

```

Status definitions
-----
Status settings for Standard User Level:
Settings          edit.      Settings          edit.
-----          -
Sample silo       off  yes    Load methods from  Internal
Auto start        off  no      Auto save data      off  no
No. of samples    9999 no      Save data to        Internal no
Statistics        off  yes    Clear working area  yes
No. data records  2    yes    Show method window  auto
Sample changer    |    no

User              |    yes
Request user name |    no
-----
QUIT

```

Most of the settings can be declared as editable or not editable.

**Sample silo** Switches on or off the sample silo. With sample silo 'on', the <SAMPLE> key on the keyboard opens the silo instead of the (single) sample input dialog.

**edit. yes/no** : with 'no' it is not possible to change the status of the sample silo in the status window.

**Auto start** Switches on or off the auto start function for processing a sample series.

**edit. yes/no** : with 'no' it is not possible to change the status of the auto start function in the status window.

**No. of samples**

Defines the number of samples to be processed.

**\*** indefinite number of samples

**sil0** all samples in the sample silo

**Rack** all samples on the sample rack

**edit. yes/no** : with 'no' it is not possible to change the number of samples in the status window.

**Statistics**

Switches on or off the statistics function.

**edit. yes/no** : with 'no' it is not possible to change the status of the statistics function in the status window.

**No. data records**

Defines the number (2...20) of determinations to be included in the statistics calculations. This setting also determines the size of the working memory.

**edit. yes/no** : with 'no' it is not possible to change the number of data records in the status window.

**Sample changer**

Address of the sample changer (1 or 2). A blank entry stands for 'no sample changer'.

**edit. yes/no** : with 'no' it is not possible to change the address of the sample changer in the status window.

**Load methods from**

Defines the storage location (Internal storage or Data card) where a method can be loaded from.

**Auto save data**

Switches on or off the auto save function. Determination data will be saved for further re-evaluation.

**edit. yes/no** : with 'no' it is not possible to change the status of the auto save function in the status window.

**Save data to**

Defines the storage location (Internal storage or Data card) where determination data can be saved.

**edit. yes/no** : with 'no' it is not possible to change the storage location in the status window.

**Clear working area**

With 'yes' the working memory, the sample silo, the statistics, the run number etc. will be cleared at start-up of the instrument or while signing on with a key card.

**Show method window**

With 'yes' the method selection window will be displayed automatically after start-up of the instrument or sign-on with a key card.

**User** User name for use with key card.  
**edit. yes/no** : with 'no' it is not possible to change the user name.

**Request user name**  
 With 'yes' a user name request will be displayed automatically after start-up of the instrument or sign-on with a key card.

**Softkey**

**[Set default]**  
 resets all settings to default values.

**13.3.3 Creating a key card**

The status definitions and the settings of the sofkey bars can be saved in an access control file. A data card containing an access control file (\*.acf) can be used as a key card.

Insert a formatted SRAM card in the memory card slot of the 796 Titroprocessor and press [File] on the Access Control page.

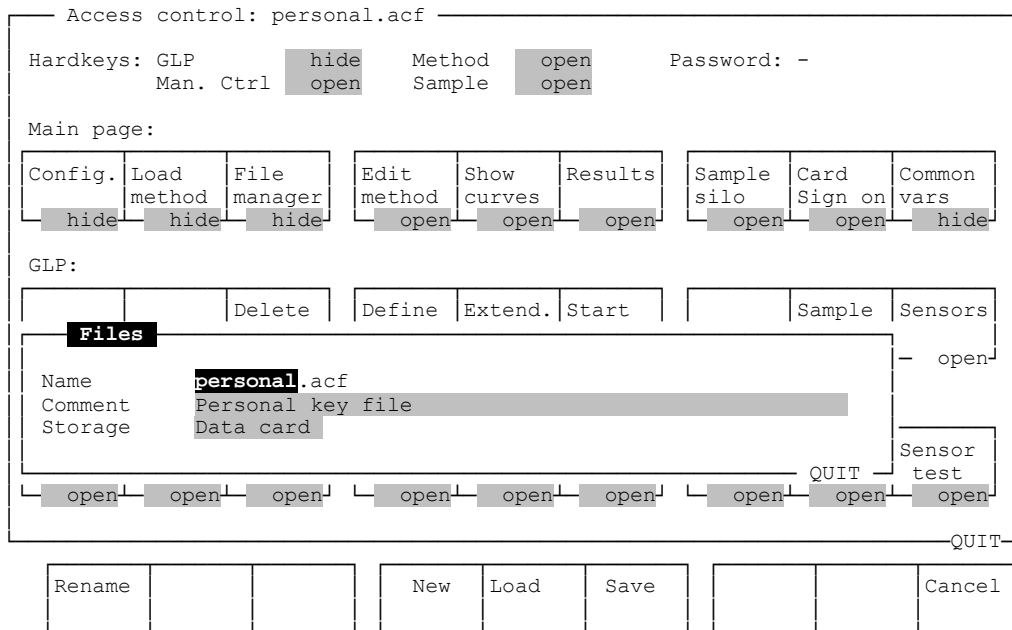

In the file dialog window a file name and a comment can be introduced. Select the storage 'Data card' and press [Save]. A key card must contain only one access control file. When a sign-on occurs the first found access control file will be loaded and its settings will effect. However, for backup purposes it is possible to store more than one access control files on a data card (or in the internal storage).

### 13.3.4 Modifying an existing Access Control file

When opening the 'File' dialog on the Access Control page, you can activate the settings of a key card by loading the Access Control file on the data card.

Select 'Data card' for storage, move the cursor to the 'Name' entry field and press the space bar.

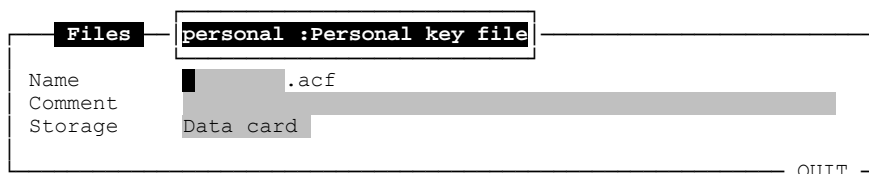

Pressing <ENTER> and the softkey [Load] will load the settings of the Access Control file. The settings (softkeys and status settings) can then be edited at will.

### 13.3.5 Monitoring a key card

A key card can be used as a 'key' to open the dialog pages of the 796 Titroprocessor. After signing on, the key card may be removed from the card slot.

The monitoring function enables an operating mode, which requires a key card constantly inserted. Removing the key card will result in an automatic sign-off, which forces a new sign-on request. The access to the 796 Titroprocessor's functions will be locked, until another key card is inserted. In order to ensure finishing the running determinations, the presence of a key card is checked **after the end** of a single determination or a sample series (with 'auto start on').

The monitoring function can be initialized on the configuration page of the 796 Titroprocessor, see below.

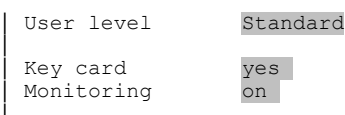

With '**Monitoring on**' a missing key card will lock the access to the instrument.

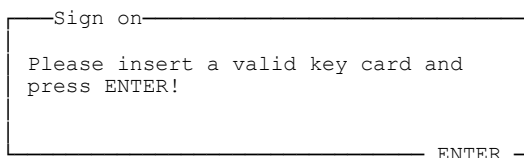

## 13.4 Remote operation / Key simulation

The Titroprocessor 796 can be remotely operated via an RS232 interface. This remote control is set up as a key simulation, i.e. from a personal computer key codes can be transmitted to the Titroprocessor 796 via the RS232 interface; the Titroprocessor interprets these as being normal keyboard operations. In addition the 'Terminal remote control mode' can be switched on (see configuration, page 36); this has the effect that the screen contents of the Titroprocessor (including ANSI character attributes) are transmitted to the PC.

### Switching on remote control

On the interface configuration page (see page 44ff) the RS232 interface connected to the computer must be set as the communication interface. The data transfer mode '**keyCTRL**' must be selected and data reception switched on.

```
|   Receive mode   on   |  
  
|   Communication Int. 1   |  
|   Commun. mode   keyCTRL   |
```

The data transfer mode '**keySEND**' is used to transmit the key codes of the keys which are pressed on the Titroprocessor.

It is possible to switch on the '**keyCTRL**' mode automatically during a method run. In this case the Titroprocessor keyboard is blocked to prevent manual entries.

Take care that the set interface parameters (baud rate, etc.) of the Titroprocessor coincide with those of the personal computer.

A simple terminal software is sufficient to control the Titroprocessor 796 from a PC. Please contact your local Metrohm agency for further technical support.

### Keyboard codes of the Titroprocessors 796

The keyboard codes of characters and numbers correspond to those of the normal ASCII character set for personal computers (IBM code page 850).

Keyboard codes for special keys (ASCII codes, decimal)

<b>QUIT</b>	0185	<b>F1</b>	0176	<b>HOLD CONT</b>	0191
<b>ENTER</b>	13	<b>F2</b>	0177	<b>SKIP</b>	0207
<b>TAB</b>	09	<b>F3</b>	0178	<b>STOP</b>	0208
<b>Shift TAB</b>	0168	<b>F4</b>	0179	<b>DELAY</b>	0209
<b>↑</b>	0166	<b>F5</b>	0180	<b>START</b>	0210
<b>↓</b>	0169	<b>F6</b>	0181	<b>NEXT</b>	0211
<b>←</b>	0174	<b>F7</b>	0182	<b>MAN CTRL</b>	0220
<b>→</b>	0253	<b>F8</b>	0183	<b>STATUS</b>	0244
<b>ALT</b>	0172	<b>F9</b>	0184	<b>METHOD</b>	0246
<b>INS</b>	0212	<b>GLP</b>	0189	<b>SAMPLE</b>	0249
<b>DEL</b>	0218	<b>HELP</b>	0190	<b>RESULT</b>	0222
<b>HOME</b>	02	<b>PRINT</b>	0186		
<b>END</b>	03	<b>STOP PRINT</b>	0202		
<b>PG UP</b>	0216	<b>LINE FEED</b>	0187		
<b>PG DN</b>	12	<b>FORM FEED</b>	0203		
<b>Backspace</b>	08	<b>PRINT SCR.</b>	0188		

## 13.5 Validation / GLP

The 796 Titroprocessor supports the monitoring of maintenance intervals as well as system validation and sensor tests.

### 13.5.1 Maintenance intervals

The maintenance of the 796 Titroprocessor should be carried out at least once per year by a service technician from your local Metrohm agency. The service technician updates the service data and enters a suitable maintenance interval.

When this maintenance interval has elapsed the 796 Titroprocessor displays a warning when it is switched on and recommends that the operator should contact the Metrohm service department.

The service data can be seen on the GLP page. They are called up by pressing the <GLP> key on the keyboard.

GLP									
Method	Validations			Date	Interval	Result			
1.									
2.									
3.									
4.									
5.									
					Instrument ident.	:	01106		
					Last servicing	:	1999-11-25		
					done by	:	B. Miller		
					Program version	:	5.796.0010		
QUIT									
		Delete method	Define method	Extend. info	Start valid.		Sample silo	Sensors	

The service data are updated by the service technician.

### 13.5.2 Sensor test

The 796 Titroprocessor offers a sensor test procedure which checks whether the pH electrode is still functioning properly. In order to guarantee the suitability of the sensor for a specific (or general) application, separate limits can be defined for each sensor; these must not be exceeded in the sensor test.

The sensor test consists of an extended calibration with automatic control of the stirrer '**Int.A**' or '**Int.B**'. The test can be carried out with any buffer set containing the buffers pH 4 and pH 7. We recommend Metrohm buffers, but other buffer sets can also be used.

### Define sensor list

Press the <GLP> key on the main and then the [Sensors] softkey.

GLP

Method	Validations	Date	Interval	Result	
<b>Sensors</b>					
Sensor ID	Manuf.no.	Part.no.	Date	Interval	Quality
1. comb. pH I	0023 0842	6.233.100	1999-12-11	1 month(s)	OK
2. comb. pH II	0023 0941	6.233.100	1999-12-10	1 month(s)	OK
3.					
4.					
5.					
6.					
7.					
8.					
9.					
10.					

QUIT

QUIT

Limits			Extend info		Delete sensor			Sensor test
--------	--	--	-------------	--	---------------	--	--	-------------

Ten sensors can be defined in the list. The test data of each listed sensor are stored and can be seen and updated at any time.

Press [Limits] to fix the limits. In the dialog window shown the limits can be defined according to the requirements of the application for which the sensor is to be used. If a sensor is not to be used for measurements but only for titrations then the limits do not need to be so closely set. The screen shown below shows the recommended standard values for normal applications. By pressing the [Set default] softkey these settings can be called up at any time.

GLP

Method	Validations	Date	Interval	Result	
<b>Sensors</b>					
Sensor ID	Manuf.Nr.	Part.Nr.	Date	Interval	Quality
1. comb. pH I	0023 0842	6.233.100	1999-12-11	1 month(s)	OK
2. comb. pH II					
3.					
4.					
5.					
6.					
7.					
8.					
9.					
10.					

**Sensor Limits**

User def. limits of: comb. pH II

---

Slope min. 0.960

Zero point (mV) max. 30.0 mV

Stream.potential max. 2.5 mV

Resp. time (1mV) max. 30 s

Test interval 1 month(s)

QUIT

QUIT

QUIT

			Set default					Cancel
--	--	--	-------------	--	--	--	--	--------

The following limits can be defined:

<b>Slope</b>	Electrode slope
<b>Zero point (mV)</b>	Asymmetry potential at pH 7 ( $U_{as}$ )
<b>Streaming potential</b>	Potential difference between stirred – unstirred buffer
<b>Response time</b>	Maximum time for measured value setting, up to 1 mV of effective measured value
<b>Test interval</b>	Interval until next sensor test

By pressing the [**Cancel**] softkey alterations in the limits can be canceled.

### Carry out sensor test

Enter a name for the sensor(s) together with its/their manufacturing and order number . Set the cursor to the line containing the sensor to be tested. Press the [**Sensor test**] key.

The screenshot shows the GLP interface with a 'Sensors' menu open. The 'Sensor test' dialog box is displayed, containing the following text:

```

1. comb. Sensor comb. pH II
2. comb.
3. Meas. input A1 Temperature 25.0 °C
4. Buffer type Metrohm Stirrer Int. A
5.
6.
7. Prepare buffer solution pH 7.00 and pH 4.00
8.
9. Press softkey [Start test] to proceed
10. QUIT
    
```

At the bottom of the screen, there are three softkey areas. The first area contains the text 'Start test'.

The sensor must be connected to measuring input A1, A2, B1 or B2. A magnetic or rod stirrer should be connected to stirrer output 1 (Sensors A) or 2 (Sensors B) on the rear panel of the Titroprocessor. The stirrer is controlled automatically. Two beakers with buffer solutions pH 7 and pH 4 must be prepared. The buffer type can be entered in the dialog window 'Sensor test'. The measuring temperature can be measured automatically with a pH electrode with a built-in Pt100 or Pt1000 temperature sensor or with a separate temperature sensor. The measuring temperature is taken into account in the sensor test.

After pressing the [**Start test**] softkey the test proceeds automatically.

**Sensor test procedure:**

- After the start of the test the sensor must be immersed in the first buffer solution (pH 7) within five seconds.
- The stirrer is switched on automatically and the potential measured for three minutes.
- The stirrer is then switched off and the potential measured for a further minute.
- The buffer must then be changed (pH 4). By pressing **[Next]** the same procedure is started again.
- The test data are displayed at the end of the sensor test.

Sensor test					
Meas. input		A1			
Temperature		25.0°C			
Buffer time/min		** pH 7.0 **		** pH 4.0 **	
		U/mV	Drift/mV/Min	U/mV	Drift/mV/Min
1	stirred	0.5	0.2	175.4	-0.4
2	stirred	0.4	0.0	175.3	-0.3
3	stirred	0.3	-0.2	175.2	-0.1
4		0.2	-0.2	175.1	-0.2
Response time		27.0 s OK		27.0 s OK	
Stream.potent.		0.1 mV OK		0.1 mV OK	
Slope		0.986 OK			
Zero point (mV)		0.3 mV OK			
pH(as)		7.004		Summary: OK	

QUIT

By pressing the **[Extend. info]** and **[Full info]** softkeys the test results of a sensor can be shown again later. The test results of the previous sensor tests are also shown.

**13.5.3 System validation**

**GLP (Good Laboratory Practice)** requires the regular checking of the reproducibility and accuracy of analytical instruments by means of standard operating procedures (SOP).

The Titroprocessor 796 should be validated as a complete, integrated titration system. A series of titrations (titer determinations are best) with primary standards is recommended. The Titroprocessor can carry out the assessment of the results and monitoring the validation intervals by itself.

In order to take the requirements of your specific applications into account, the limiting values for the assessment of the reproducibility and accuracy of the determinations can be individually set.

The validation can be carried out with any determination method which is stored in the internal memory or on a data card. A simple modification of the calculation formula will ensure the correct evaluation of the relevant data.

The method must contain the following results from the calculation formula:

- Result for the statistical calculations  
**RT1=...**
- Theoretical result as numerical value  
**RT2=...**
- Endpoint which is to be used for the calculation of the systematic error  
**RE=EPx** (x=0...9)

Example of a titer determination for hydrochloric acid with TRIS as sample substance.

* Formula					
#	Comment	Formula (R\$\$, C##, X\$\$, EP# ...)	Unit	Dec	Type
* 1	Titer	RT1=SS*1000/0.1/121.14/EP1		4	stat.
* 2	Titer (theo)	RT2=1.0000		4	stat.
* 3	Consumpt.	RE=EP1	mL	3	stat.

The method must be stored.

### 13.5.4 Preparing for a validation

Call up the main page and press the <GLP> key.

GLP				
Method	Validations	Date	Interval	Result
1. HCl	Validation method			
2.				
3.				
4.				
5.				
		Instrument ident.	: 01106	
		Last servicing	: 1999-11-25	
		done by	: B. Miller	
		Program version	: 5.796.0010	
QUIT				

		Delete method	Define method	Extend. info	Start valid.		Sample silo	Sensors
--	--	---------------	---------------	--------------	--------------	--	-------------	---------

Five different validation methods can be defined for different purposes. Select a line and press the [**Define method**] softkey.

```

Validation Method Definition
-----
Method      HCl      .mth
Comment     Validation method
Storage     Internal

Limits
-----
Mean value      0.990  1.010
Standard deviation absolute ± 0.005
Standard deviation relative ± 0.5 %
Systematic deviation d(rel) ± 1.0 %
Systematic error (intercept) ± 0.050 mL

Validation interval 12 month(s)
-----
QUIT
    
```

Select a memory area (internal memory or data card) and a stored method. In order to open a selection list use the space bar or the **[Cancel]** soft-key. Enter a comment and set the limits for the validation results.

### Limiting values and their meaning

The validation results represent and provide a reliable assessment of the accuracy and reproducibility of your titration system, including dosing devices and sample changer.

**Mean value** The mean value of all determination results (**RT1**) of the validation series. At least 10 determinations should be carried out. We recommend titer determinations as validation methods.  
Standard limiting value **0.990...1.010**

**Standard deviation absolute**  
Absolute standard deviation of the results (**RT1**) of the validation series.  
Standard limiting value **± 0.005** (for titer determinations)

**Standard deviation relative**  
Relative standard deviation in percent.  
Standard limiting value **± 0.5%**

**Systematic deviation d(rel)**  
Systematic deviation of mean value against theoretical result (**RT2**).

$$d_{rel} = \frac{\text{result}_{\text{mean}} - \text{result}_{\text{theo}}}{\text{result}_{\text{theo}}} * 100$$

Standard limiting value **± 1.0%**

**Systematic error (a<sub>sys</sub>)**  
Systematic error, caused by interfering influences such as solvent blank values or method-related problems. It is determined by the axis intercept of the linear regres-

sion of the endpoint volume (**RE**) against sample size (**SS**).

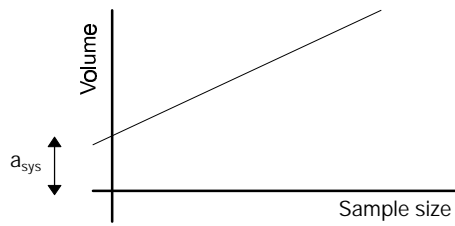

Standard limiting value  $\pm 0.050$  mL

#### Validation interval

Time interval for the validity of the validation. If a validation has expired a message will be shown each time the Titroprocessor is switched on.

Standard limiting value '12 month(s)'

Press the [**sample silo**] softkey on the **GLP** main page to enter the sample weight. The sample weights should be scattered at random within a wide range. The sample silo can be stored and called up at a later date.

By pressing the [**Start valid.**] softkey the validation can be started. You will be required to answer the following questions:

Do you really want to overwrite current method [y]

Do you really want to reset all statistics data [y]

Do you want to set statistics 'on' [y]

Do you want to set silo 'on' [y]

Do you want to set auto start 'on' [y]

Did you set up all necessary silo data [y]

Do you change samples manually [n] (\*)

Accept all previous settings [y]

When all standard settings have been confirmed by pressing the <**ENTER**> key the validation can be carried out after you have entered your name as operator.

Validation of **xx-xx-xx** done by user: [ ]

---

**Explanation:**

---

It is recommended that all current data (methods and determinations) are stored before a validation is carried out. In order to obtain correct statistical calculations the working memory must be cleared.

Validations must be carried out with **auto start** and **Silo 'on'**. If a sample changer is connected you may select whether the sample changer is to be used or if the samples are to be changed manually, see (\*) above.

When the validation series is finished a validation report will be printed out automatically and the results can be viewed on the GLP page (<GLP> key and [**Extend. info**] softkey). In the window of the validation information a further softkey [**Histogram**] is available with which the results of the last 10 validations can be shown graphically and thus the alterations in the reliability of the analytical system can be assessed.

The validation results are shown in a histogram against time. The Y-axis (mean value) is automatically scaled.

## 13.6 Technical specifications

Compact titration and measuring instrument for analyses in the laboratory and plant. Connection possibilities for 1 or 2 sample changers, 4 potentiometric sensors (pH / mV), 2 polarizable electrodes, 2 temperature sensors.

32-bit microprocessor, 16 MHz clock frequency, 2 Mbyte battery-backed SRAM, 2 Mbyte EPROM.

Genuine multitasking with dynamic memory management.

Dimensions	<i>Height</i>	With built-in printer 205 mm, without printer 175 mm
	<i>Width</i>	405 mm
	<i>Depth</i>	500 mm
Weight	With built-in printer 12.6 kg, without printer 11.1 kg	
Material	<i>Housing</i>	Polyurethane rigid foam with fire protection for fire class UL94VO, FCHC-free
Power supply	<i>Line voltage</i>	100...120 V $\pm$ 10 %, 220...240 V $\pm$ 10 %
	<i>Line frequency</i>	50...60 Hz
	<i>Power consumption</i>	Max. 160 VA
	<i>Fuse</i>	2 ATH (slow-blow, high breaking capacity) 5 mm $\varnothing$ , length 20 mm
Screen	<i>Type</i>	LCD screen, backlit
	<i>Screen diagonal</i>	257 mm
	<i>Resolution</i>	640 x 400 dots, 4 gray levels; 28 lines each of 80 characters
	<i>Refresh rate</i>	72 Hz
	<i>Contrast</i>	Adjustable
Keyboard	Tactile touch keyboard with action point, splashwater-proof	
Interfaces	2 x RS 232C for serial data communication with balance, PC or printer	
	<i>Standard</i>	EIA RS232C, CCITT V.24, ISO 2110, DIN 66020
	<i>Socket</i>	D-subminiature 25-pin
	<i>Max. baud rate</i>	9600
	Remote interface for the control of external devices	
	<i>Type</i>	Logical control lines
	<i>Lines</i>	8 Output (open collector), $V_{CE} = 40$ V, $I_C = 20$ mA
		8 Input, (pull-up 5 V)
		1 Power supply, 4...5.5 V, 200 mA
		1 GND

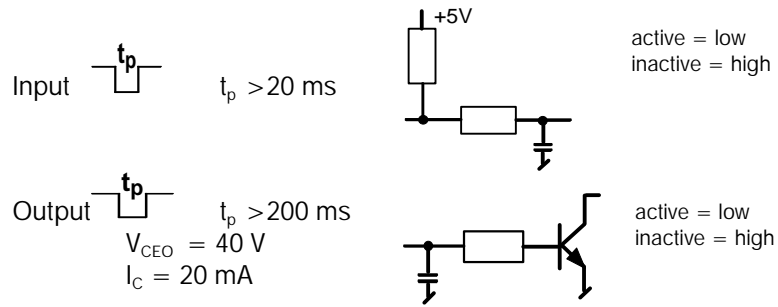

Printer  
(option)

*Type* Thermal printer  
*Paper* 6.2237.040 Continuous thermal paper A4, perforated  
*Resolution* 84 dpi in alphanumeric mode  
 160 dpi in graphics mode

Connections

- Bar-code reader connection for data entry

*Connector* D-subminiature 9-pin (RS232C style)  
*Transmission settings* Baud rate 9600  
 Data bit 8  
 Stop bit 1  
 Handshake RTS/CTS  
*String terminator* CR/LF  
*Input buffer* 40 characters  
*Character set* 7-Bit ASCII  
*Pin assignment*

Pin 1	empty	Pin 6	empty
Pin 2	TxD (output)	Pin 7	RTS (output)
Pin 3	RxD (input)	Pin 8	CTS (input)
Pin 4	empty	Pin 9	+5 V
Pin 5	GND (0 V)		

*Wiring*

	<i>796 socket</i>	<i>Bar-code reader</i>
TxD	→	RxD
RxD	←	TxD
RTS	→	CTS
CTS	←	RTS
GND	—	GND
+5 V	→	+5 V

- Connections for four 700 Dosinos or 685 Dosimats

*Connector* D-subminiature 9-pin

- 1 or 2 stirrer connections for 728 Magnetic Stirrer

*Output voltage* 10.8...13.2 V  
*Current* 250 mA  
 Short-circuit-proof and switchable

- Metrohm external bus connection for
  - Two 717 Sample Changers
  - Two Dosimat interfaces each for four 700 Dosinos or 685 Dosimats

- Printer connector (option), parallel port for standard printer

*Connector* D-subminiature 25-pin

- Measurement group 1 or 2 (option) measurement groups each with
- 2 high-impedance measurement inputs for pH, redox, ISE sensors
  - 1 input for separate reference electrode
  - The above inputs also serve as a differential amplifier
  - 1 measurement input for polarized electrodes
  - 1 measurement input for Pt 1000 or Pt 100 temperature sensors, with automatic recognition
  - 1 polarizer
  - 2 parallel A/D-converters, 20 bit, 50 ms sampling rate
  - 1 stirrer connector (see above)

#### Electrical insulation

All interface signals are referred to a common reference potential. The reference source is electrically insulated from the main circuit. Each measurement interface is insulated individually as well.

The electrical insulation is due to the measuring technique. It does not comply with certain security specifications.

Measurement ranges	<i>Potentiometric</i>	-2500 mV...2500 mV pH-20.000...20.000
	<i>Amperometric</i>	-250 $\mu$ A...250 $\mu$ A (Upol)
	<i>Voltametric</i>	-2500 mV...2500 mV (Ipol)
	<i>Temperature</i>	-150 °C...450 °C

Measuring inaccuracy	Limits	Inputs	Abs. error	Resolution
		Ind A1, A2, B1, B2	$\leq \pm 0.8$ mV	5 $\mu$ V
		Diff A, Diff B	$\leq \pm 4.0$ mV	5 $\mu$ V
		Pol ( $\mu$ A, Upol)	$\leq \pm 3$ $\mu$ A	0.001 $\mu$ A
		Pol (mV, Ipol)	$\leq \pm 20$ mV	5 $\mu$ V
		Pt100/1000 0°C...100°C	$\leq \pm 0.3$ °C	0.005°C

#### Reference conditions

The measurement error limits are guaranteed at works, measured at an ambient temperature of 25°C ( $\pm 5$ °C) after 5 min. operating time.

The error limit of the temperature measurement applies to the socket contact resistance as well as to the sensor cable of the Metrohm (6.1103.0000) Pt100 Temperature Sensor. It does not consider the sensor inaccuracy.

Polarizer source accuracy	Polarizer voltage (Upol)	
	<i>Range</i>	-1270 mV...1270 mV
	<i>Linearity</i>	$\leq \pm 20.0$ mV
	<i>Resolution</i>	10.0 mV
	Polarizer current (Ipol)	
	<i>Range</i>	-127 $\mu$ A...127 $\mu$ A
	<i>Linearity</i>	$\leq \pm 3.0$ $\mu$ A
	<i>Resolution</i>	1.0 $\mu$ A

Ambient temperature	<i>Nominal operating range</i>	5...40 °C
	<i>Storage, transport</i>	-25...60 °C

Ambient atmospheric humidity	<i>at 40 °C</i>	max. 95% relative humidity
	<i>at 45 °C</i>	max. 70% relative humidity
	<i>at 60 °C</i>	max. 35% relative humidity

#### Titration and measurement modes

<b>DET</b>	Dynamic equivalence-point titration; U, pH, $I_{pol}$ , $U_{pol}$
<b>MET</b>	Monotonic equivalence-point titration; U, pH, $I_{pol}$ , $U_{pol}$
<b>SET</b>	Titration to preset endpoint; U, pH, $I_{pol}$ , $U_{pol}$
<b>SEC</b>	Conditioning to preset endpoint; U, pH, $I_{pol}$ , $U_{pol}$
<b>KFT</b>	Karl Fischer endpoint titration; $I_{pol}$ , $U_{pol}$
<b>KFC</b>	Conditioning according to Karl Fischer; $I_{pol}$ , $U_{pol}$
<b>MEAS</b>	Measurement; U, pH, $I_{pol}$ , $U_{pol}$ , T
<b>CAL</b>	pH calibration

Memories	<i>Program memory</i>	EPROM, max. 4 MB
	<i>Data memory</i>	2 MB SRAM, battery backed
	<i>Determination memory</i>	for up to 20 determination data records each with up to 5 titrations or measurements
	<i>Method memory</i>	for freely definable sequence, up to 99 command lines
	<i>Silo memory</i>	sample data memory for up to 160 sample data records
	<i>File memory</i>	free RAM area for the storage of determinations, methods, sample data tables
Memory card	<i>Type</i>	Memory card according to standard JEIDA 4.X / PCMCIA 2.X (68 pins)
	<i>Memory capacity</i>	2 MB (6.2245.030), 128 kB (6.2245.010); other versions up to 2 MB applicable

Safety specifications	Construction and testing in accordance with IEC 1010 / EN 61010 / UL 3101-1, protection class I
	Degree of protection IP 52

The instruction manual contains information and warnings which the user should follow to guarantee the safe operation of the instrument.

#### Electromagnetic compatibility (EMC)

<i>Emitted interference</i>	The 796 Titroprocessor complies with the basic specifications EN 50081-1 01.92, EN 55011 (class B), EN 55022 (class B), and NAMUR.
-----------------------------	--

<i>Noise immunity</i>	The standards EN 50082-2: 1995, IEC801-2 up to IEC801-6, EN 60555-2 and NAMUR are complied with.
-----------------------	--

## 13.7 Warranty and certificates

### 13.7.1 Warranty

---

The warranty regarding our products is limited to rectification free of charge in our workshops of defects that can be proved to be due to material, design or manufacturing faults which appear within 12 months from the day of delivery. Transport costs are chargeable to the purchaser.

For day and night operation, the warranty is valid for 6 months.

Glass breakage in the case of electrodes or other glass parts is not covered by the warranty. Checks which are not a result of material or manufacturing faults are also charged during the warranty period. For parts of outside manufacture insofar as these constitute an appreciable part of our instrument, the warranty stipulations of the manufacturer in question apply.

With regard to the guarantee of accuracy, the technical specifications in the Instructions for Use are authoritative.

Concerning defects in material, construction or design as well as the absence of guaranteed features, the purchaser has no rights or claims except those mentioned above.

If damage of the packaging is evident on receipt of a consignment or if the goods show signs of transport damage after unpacking, the carrier must be informed immediately and a written damage report demanded. Lack of an official damage report releases METROHM from any liability to pay compensation.

If any instruments and parts have to be returned, the original packaging should be used if at all possible. This applies above all to instruments, electrodes, buret cylinders and PTFE pistons. The parts must be packed in a dustproof package (for instruments the use of a plastic bag is imperative) before embedding them in wood shavings or similar material. If open assemblies are enclosed in the scope of delivery that are sensitive to electromagnetic voltages (e.g. data interfaces, etc.) these must be returned in the associated original protective packaging (e.g. conductive protective bag).

**Exception:** Assemblies with built-in voltage source belong in a non-conductive protective packaging. For damage which arises as a result of non-compliance with these instructions no warranty responsibility whatsoever will be accepted by Metrohm.



### 13.7.2 EC Declaration of conformity

---

The METROHM AG company, Herisau, Switzerland hereby certifies, that the instrument:

#### **796 Titroprocessor**

meets the requirements of EC Directives 89/336/EWG and 73/23/EWG.

#### **Source of the specifications:**

EN 50081-1 01.92 Electromagnetic compatibility, basic specification  
Emitted Interference

EN 50082-2:1995 Electromagnetic compatibility, basic specification

Interference Immunity

EN 61010 Safety requirements for electrical laboratory measurement and control equipment

#### **Description of the instrument:**

Highly integrated titrator for analytical purposes in laboratory and industry; master device for titration and measuring systems in conjunction with peripheral dosing devices, sample changers and various sensors.

Herisau, February 15, 2000



Dr. J. Frank

Development Manager

Ch. Buchmann

Production and  
Quality Assurance Manager

### 13.7.3 Certificate of conformity and system validation

This is to certify the conformity to the standard specifications for electrical appliances and accessories, as well as to the standard specifications for security and to system validation issued by the manufacturing company.

Name of commodity:	796 Titroprocessor
System software:	Stored in ROMs
Name of manufacturer:	Metrohm Ltd., Herisau, Switzerland
Principal technical information:	Voltages: 100...120, 220...240 V
	Frequency: 50...60 Hz

This Metrohm instrument has been built and has undergone final type testing according to the standards:

IEC801-2/IEC1000-4-2 (level 4), IEC801-3 (level 2), IEC801-4/IEC1000-4-4 (level 3), IEC 801-5/IEC1000-4-5 (level 2/3), IEC801-6/IEC1000-4-6 (level 2), EN55011 / class B, EN55022 / class B, EN50081-1 01.92, EN 50082-2:1995, EN60555-2 — *Electromagnetic compatibility*

IEC1010, EN61010, UL3101-1 — *Security specifications*

It has also been certified by the Swiss Electrotechnical Association (SEV), which is member of the International Certification Body (CB / IEC).

The technical specifications are documented in the instruction manual.

The system software, stored in Read Only Memories (ROMs) has been validated in connection with standard operating procedures in respect to functionality and performance. The features of the system software are documented in the instruction manual.

Metrohm Ltd. is holder of the SQS-certificate of the quality system ISO 9001 for quality assurance in design/development, production, installation and servicing.

Herisau, February 15, 2000



Dr. J. Frank

Development Manager

Ch. Buchmann

Production and  
Quality Assurance Manager

## 13.8 Scope of delivery and accessories

### 13.8.1 Titroprocessors

796 Titroprocessor with 1 measurement group, without printer	2.796.0010
includes the following accessories:	
Data card (SRAM) JEIDA4/ 2 Mbyte	6.2245.030
Dust cover	6.2723.280
Application card (FLASH card)	6.6038.000
Metrodata 796 PC Backup software	6.6039.000
Instructions for use	8.796.1003
Tutorial	8.796.1023
796 Titroprocessor with 1 measurement group, with built-in printer	2.796.0020
includes the following accessories:	
Data card (SRAM) JEIDA4/ 2 Mbyte	6.2245.030
Thermal paper, roll of app. 40 m	6.2237.040
Paper reel, axis for thermal paper roll	6.2241.020
Dust cover	6.2723.280
Application card (FLASH card)	6.6038.000
Metrodata 796 PC Backup software	6.6039.000
Instructions for use	8.796.1003
Tutorial	8.796.1023
796 Titroprocessor with 2 measurement groups, without printer	2.796.0110
includes following accessories	
Data card (SRAM) JEIDA4/ 2 Mbyte	6.2245.030
Dust cover	6.2723.280
Cable for 622/703/728 stirrer	6.2108.110
Application card (FLASH card)	6.6038.000
Metrodata 796 PC Backup software	6.6039.000
Instructions for use	8.796.1003
Tutorial	8.796.1023
796 Titroprocessor with 2 measurement groups, with built-in printer	2.796.0120
includes the following accessories:	
Data card (SRAM) JEIDA4/ 2 Mbyte	6.2245.030
Thermal paper, roll of app. 40 m	6.2237.040
Paper reel, axis for thermal paper roll	6.2241.020
Dust cover	6.2723.280
Cable for 622/703/728 stirrer	6.2108.110
Application card (FLASH card)	6.6038.000
Metrodata 796 PC Backup software	6.6039.000
Instructions for use	8.796.1003
Tutorial	8.796.1023

### 13.8.2 Options

---

Accessories to separate order at additional charge:

#### Dosing drives

---

685 Dosimat		2.685.0010
Cable 685 — 796		6.2134.000
Exchange Unit with ceramic stopcock		
	1 ml	6.3013.113
	5 ml	6.3013.153
	10 ml	6.3013.213
	20 ml	6.3013.223
	50 ml	6.3013.253
Exchange Unit with PTFE stopcock		
	1 ml	6.3014.113
	5 ml	6.3014.153
	10 ml	6.3014.213
	20 ml	6.3014.223
	50 ml	6.3014.253
700 Dosino		2.700.0010
Dosing unit for Dosino		
	2 ml	6.3031.120
	5 ml	6.3031.150
	10 ml	6.3031.210
	20 ml	6.3031.220
	50 ml	6.3031.250
729 Dosimat Interface		2.729.0010
728 Magnetic Stirrer		2.728.0040
727 Ti-Stand with Rod Stirrer		2.727.0010 2.722.0010
727 Ti-Stand with Magnetic Stirrer		2.727.0100
703 Ti-Stand		2.703.0010

#### Sample Changer 717

---

717 Sample Changer with 1 work station, 1 pump	2.717.0010
717 Sample Changer with 1 work station, 2 pumps	2.717.0020
717 Sample Changer with 1 work station, no pump	2.717.0030
717 Sample Changer, 2 work stations, 1 pump each	2.717.0110
717 Sample Changer, 2 work stations, 2 pumps each	2.717.0120
717 Sample Changer, 2 work stations, no pumps	2.717.0130
759 Swing head, for use with multi-row racks	2.759.0020

722 Rod stirrer for the sample changer	
Rod stirrer	2.722.0020
Stirrer propeller PP (104 mm)	6.1909.020
741 Magnetic stirrer	
Magnetic stirrer	2.741.0010
Macro Titration head (6x NS14, 3x NS9)	6.1458.010
Micro Titration head (4x M10)	6.1458.020

### Sample racks and beakers

Rack 12x 250 ml M12-0 *)	6.2041.310
Metrohm glass beaker 250 ml	6.1432.320
Metrohm PP beaker 200 ml	6.1453.220
Metrohm PP beaker 250 ml	6.1453.250
Rack 12x 150 ml M12-0 *)	6.2041.360
for standard glass beaker 150 ml (narrow) or	
disposable beaker (Euro) PP 200 ml (1000 pcs.)	6.1459.310
Rack 14x 200 ml M14-0	6.2041.370
for disposable beaker (Euro) PP 200 ml	6.1459.310
Rack 14x 8 oz M14-0	6.2041.380
for disposable beaker (US) PP 8 oz	
Rack 16x 150 ml M16-0	6.2041.320
for standard glass beaker (narrow)	
Rack 24x 75 ml M24-0 *)	6.2041.340
(with Micro titration head only)	
Metrohm glass beaker 75 ml	6.1432.210

\*) Parallel processing at 2 towers possible

Other sample racks on request.

### Electrodes

comb. pH glass electrode with SGJ, without cable	6.0233.100
comb. pH glass electrode, without cable	6.0232.100
comb. micro pH glass electrode, without cable	6.0234.100
comb. pH glass electrode with built-in	
temperature sensor, with SGJ	6.0238.000
Temperature sensor (Pt1000) with SGJ, no cable	6.1110.100
Electrode cable, 1m	6.2104.020
Cable for temperature sensor	6.2104.080
SGJ sleeve for electrode without SGJ	6.1236.040

Use standard length electrodes (with SGJ or SGJ sleeve) in general.  
For special applications or sample beakers electrodes with other lengths are available. See latest sensor catalogue of your Metrohm supplier.

## Electrodes for Sample Changers

It is recommended to use Longlife-Electrodes (LL) or titrodes (without polished glass surface) with the SGJ sleeve SGJ14/12mm 6.1236.040 made of silicon rubber for titrations with the Macro Titration head.

The following special changer electrodes can be used with the Micro Titration head.

Comb. micro-pH-electrode (LL)	16 cm	6.0234.110
Micro reference electrode Ag/AgCl	16 cm	6.0736.100
Micro glass electrode	16 cm	6.0134.110
Micro-Ag titrode	16 cm	6.0433.110
Micro-Pt titrode	16 cm	6.0434.110
Micro-Au titrode	16 cm	6.0435.110

## Bar-code Reader

---

On request

# 14 Index

- .....122; 185; 186  
 ! .....73; 217  
 # .....95; 228  
 \$AS .....85; 122  
 \$BC .....85; 122; 182  
 \$CRF .....122; 155; 169  
 \$LD .....122  
 \$LM .....122  
 \$LV .....122  
 \$RN .....85; 122  
 ( ) .....122  
 (CAL...)CAL .....182  
 (CASE...)CASE .....197  
 (CMOVE) .....191  
 (OMOVE) .....190  
 )CMOVE .....191  
 )OMOVE .....190  
 \* .....32; 64; 66; 87;  
 .....122; 202; 205; 228  
 \*.acf .....276  
 \*.dtm .....35  
 \*.rck .....41  
 \*FullRes .....124  
 \*Param .....124  
 \*ShrtRes .....124  
 \*Stand .....124  
 / .....122  
 ? .....228  
 @ .....73  
 ^ .....10; 122  
 + .....122; 185; 186  
 < .....88; 95; 96; 98; 197  
 <= .....197  
 <> .....197  
 = .....197  
 > .....95; 96; 97; 197  
 -> .....228  
 >= .....197

## Softkeys

[ >> >>] .....75; 96  
 [\* Param] .....75  
 [\* Report] .....75; 124  
 [\*Formula] .....75; 215; 220  
 [\*Param] .....215; 220  
 [\*Report] .....215; 220  
 [<-- Out pointer] .....88; 96  
 [<--Out pointer] .....98  
 [--> In pointer] .....88; 96; 97  
 [>> >>] .....38; 215; 220  
 [685 Dosimat ] .....48  
 [700 Dosino ] .....48  
 [Access control] .....37; 273  
 [Add curves] .....220; 223  
 [Add series] .....59; 61  
 [Buret unit] .....37  
 [Calib. data] .....215; 220  
 [Calibr.] .....57; 58  
 [Cancel calibr.] .....59  
 [Cancel] .....14  
 [Change passwd.] .....274  
 [Change storage] .....226; 227  
 [Change view] .....226; 227

[Changer 1/2] .....41; 43  
 [Check limits] .....141  
 [Check type] .....48  
 [Clear calibr.] .....59; 62  
 [Common vars] .....270  
 [Config idents] .....37  
 [Config.] .....34  
 [Copy line(s)] .....95  
 [Copy line] .....75; 96; 121  
 [Copy to] .....227  
 [Cut line] .....75; 96; 121  
 [Define method] .....284  
 [Delete all] .....42; 48; 271  
 [Delete ComVar] .....271  
 [Delete line(s)] .....95  
 [Delete line] .....48; 75; 121  
 [Delete type] .....41  
 [Delete] .....227  
 [Determ. report] 74; 76; 214  
 [Determ. view] .....218  
 [Device header] .....37  
 [Devices ManCtrl] .....53  
 [Dosing drive] .....55; 56  
 [Edit method] .....71  
 [Edit mode] .....95; 96  
 [Empty] .....55  
 [EP Recogn.] .....225  
 [Extend. info] .....283; 287  
 [Extend. values] .....215  
 [File manager] .....226  
 [File] .....37; 71; 72; 74;  
 .....95; 216; 274  
 [Fill all] .....55  
 [Fill] .....55; 56  
 [Format card] .....228; 229  
 [Full info] .....283  
 [Global reports] .....68  
 [Help on entry] .....14  
 [Histogram] .....287  
 [HOLD CONT] .....56  
 [Insert line] .....75; 95; 121  
 [Interfaces] .....37; 44  
 [Lift down] .....64; 65  
 [Lift up] .....64; 65  
 [Limits] .....281  
 [Load from] .....227  
 [Load method] .....81  
 [Local ComVars] .....215; 220  
 [Meas] .....57  
 [New] .....72  
 [Note] .....74  
 [Paste line] .....75; 96; 121  
 [Prepare buret] .....55  
 [Preset series] .....59; 61  
 [Print] .....68  
 [Pump on/off] .....64  
 [Rack File] .....41  
 [Rates] .....48  
 [Recalc all] .....216  
 [Recalc one] .....216  
 [Receive from RS] .....228; 230  
 [Records] .....220

[Remark] .....94; 95  
 [Remote lines] .....64; 66  
 [Reset changer] .....64  
 [Reset RS232 1/2] .....46  
 [Sample changer] .....38  
 [Sample data] .....214; 221  
 [Sample idents] .....96; 97  
 [Sample silo] .....88; 93; 286  
 [Save] .....74  
 [Select determ.] 68; 69; 218  
 [Select file] .....219; 222  
 [Select report] .....68; 69  
 [Select] .....14; 214; 228  
 [Send to RS] .....228; 230  
 [Send] .....68  
 [Sensor test] .....282  
 [Service diagn.] .....38  
 [Set all open] .....274  
 [Set default] .....276; 281  
 [Shift auto] .....66  
 [Shift left] .....64; 65  
 [Shift right] .....64; 65  
 [Shift to pos.] .....64; 65  
 [Show cursor] .....221  
 [Show curve] .....59; 61  
 [Show curves] .....219  
 [Sort by] .....228  
 [Special beakers] .....41; 42  
 [Start dosing] .....56  
 [Start Stop] .....58; 59  
 [Start valid.] .....286  
 [Statist view] .....218  
 [Statistics] .....216  
 [Status defin.] .....274  
 [Stirrer on/off] .....64; 66  
 [STOP all] .....55  
 [STOP] .....55; 56  
 [Un/Lock file] .....227  
 [Un/Mark all] .....95; 227  
 [Un/Mark] .....95; 217; 227

## Keys

ALT+- .....9  
 ALT+A .....9  
 ALT+T .....9  
 ALT+U .....9  
 ALT+V .....9  
 ALT+X .....9  
 <←> .....14; 15  
 <[ ← ]> .....14  
 <←> .....221  
 <→> .....221  
 <↕> .....223  
 <↕> .....223  
 <↑><↕> .....223  
 <↑><↕> .....93; 223  
 <↑><ALT><DEL> .....257  
 <↑><HOLD / CONT> .....80  
 <↑><LINE FEED> .....67  
 <↑><PRINT> .....67  
 <↑><START> .....81

- <↑><STOP> .....81  
 <↑><TAB> ..... 54; 217  
 <ALT><↕> ..... 34; 257  
 <ALT><↕> ..... 34; 257  
 <ALT><A> .....273  
 <BACKSPACE> .....14  
 <Cursor down> ..... 8; 9  
 <Cursor left> ..... 8; 9  
 <Cursor right> ..... 8; 9  
 <Cursor up> ..... 8; 9  
 <DEL> ..... 8; 9; 14  
 <DELAY > .....81  
 <END> ..... 8; 9  
 <ENTER> .....14  
 <F1> to <F9> .....13  
 <FORM/LINE FEED> .....18  
 <GLP> ..... 9; 280; 281; 284  
 <HELP> .....9  
 <HOLD / CONT> .....80  
 <HOLD CONT> .....208  
 <HOME> ..... 8; 9; 14; 65  
 <INS> ..... 8; 9  
 <LINE FEED> ..... 8; 67  
 <MAN CONTROL> ..... 53  
 <METHOD> .....71  
 <NEXT> .....81  
 <PG DN> ..... 8; 9; 40; 54; 65  
 <PG UP> ..... 8; 9; 40; 54; 65  
 <PRINT SCREEN> ..... 8; 67; 225  
 <PRINT> ..... 8; 67; 225  
 <QUIT> .....14  
 <RESULT> .....218  
 <SAMPLE> .....92  
 <Shift><DEL> ..... 8; 9  
 <Shift><TAB> ..... 14; 15  
 <SKIP> .....80  
 <SPACE> .....14  
 <START> .....80  
 <STATUS> .....82  
 <STOP> .....80  
 <TAB> ..... 14; 15; 54; 217
- 1st derivative .....125  
 2.726.0010 .....3  
 2.726.0020 .....3  
 2.726.0110 .....3  
 2.726.0120 .....3  
 2-methoxyethanol .....113  
 6.2125.020 connection cable ...29  
 6.2125.060 Connection cable...33  
 6.2141.020 Standard remote  
   cable ..... 31; 201  
 685 Dosimat ..... 23; 289; 296  
 685 Dosimat ..... 47; 48; 51; 55  
 700 Dosino ..... 23; 289; 296  
 700 Dosino ..... 47; 48; 49; 55  
 703 Ti-Stand ..... 211; 296  
 703 Ti-Stand .....66  
 703 Titration stand .....26  
 710 dosing unit .....23  
 717 Sample changer ..... 25;  
   ..... 184; 296  
 722 Rod stirrer . 26; 189; 211; 297  
 722 Rod stirrer .....66  
 727 Ti-Stand ..... 211; 296  
 727 Ti-Stand .....66  
 727 Titration stands .....26  
 728 Magnetic stirrer . 26; 211; 296  
 728 Magnetic stirrer .....66
- 729 Dosimat interface .....23;  
   .....24; 296  
 731 Relay box .....201  
 741 Magnetic stirrer .....189; 297  
 759 Swing head .....39; 43; 296
- ### A
- A1 ... A4 .....53  
 A1, A2 .....53  
**ABS0** .....122  
 absolute .....132; 160  
 absolute start volume .....160  
 absolute stop volume .....135  
 access control .....9; 37  
 access control file...273; 276; 277  
 access controls .....272  
 accessories .....295; 296  
 accuracy .....283  
 action keys .....8  
 active .....32; 198; 202  
**ADD\_A** .....192  
**ADD\_R** .....194  
 address .....189  
 address selector .....24  
 Adiff .....53  
 adjustment .....134; 150;  
   .....157; 162; 170  
 air bubbles .....55  
 aldehydes .....113  
 all .....125; 140  
 amines .....113  
 amperometric measurement  
   .....115; 176  
 amperometric titration .....135;  
   .....152; 163  
 analytical system .....22  
**AND** .....197  
 AND balances .....27  
 ANSI .....36  
 AP .....122; 179  
 Apol .....53  
 application note .....13; 74  
 application possibilities .....1  
 ASCII character set .....10; 279  
 ASCII strings .....204  
**ASK** .....92; 207  
 aspiration pump .....189  
 aspiration tube .....49  
 assignment parameters .....130  
 asymmetry pH .....61  
 asymmetry potential .....282  
 asys .....285  
 AT .....53  
 auto .....97; 134; 150;  
   .....151; 162; 174; 180; 185; 224  
 auto save .....82; 86; 87  
 auto save data .....275  
 auto save function .....86  
 auto start .....82; 83; 87; 274  
 autocopy .....96  
 automated calibration .....179  
 automated systems .....31  
 automatic calibration .....182  
 automatic equivalence point  
   recognition .....102; 105  
 automatic page feed .....46  
 automatic storage .....82  
 autostart counter .....85  
 auxiliary commands .....207  
 auxiliary reagents .....192
- axis intercept .....285  
 axis of time .....135
- ### B
- B1 ... B4 .....53  
 B1, B2 .....54  
 background conditioning  
   process .....110; 114; 168  
 backup software .....229  
 balance .....27; 45; 83; 88; 97; 207  
 balance manufacturer .....28  
 bar-code .....207; 289  
 barcode reader .....30; 93; 298  
 basic settings .....34  
 battery .....6; 19  
 battery change .....19; 20  
 baud rate .....45  
 Bdiff .....54  
 beaker .....39  
 beaker sensor .....185; 186  
 beaker test mode .....185  
 beakers .....40; 297  
 Beckman .....181  
**BEEP** .....211  
 begin ... end .....143; 224  
 bit .....32  
 bit pattern .....32; 201; 203  
 blank value .....111  
 blind out .....37  
 blocked .....37  
 both .....185  
 Bpol .....54  
 brightness .....34  
 BT .....54  
 bubble formation .....50; 52  
 bubbles .....136; 164; 193  
 buffer counter .....85; 182  
 buffer series .....61  
 buffer solutions .....59; 61; 181  
 buffer table .....59; 61; 181  
 buffer type .....61; 181  
 buffers .....59  
 buret cylinders ...50; 51; 133; 136;  
   .....138; 145; 153; 157; 161;  
   .....164; 166; 193  
 buret unit .....37; 49; 51; 194  
 buret unit type .....48  
 buret units .....47; 55  
 by edit .....271
- ### C
- C .....122; 130  
 C## .....121  
 C\_Curve .....124  
 C1 ... C4 .....53  
 C1...C19 .....270  
**CAL** .....179  
 CAL\* mode parameters .....181  
 calc .....125  
 calculation formula .....75; 119  
 calculation report .....125  
 calculations .....85; 213; 284  
 CalData .....124  
 calibration .....57; 58; 179  
 calibration curve .....59; 61;  
   .....118; 124  
 calibration data .....58; 62; 124;  
   .....215; 220  
 calibration errors .....183  
 calibration interval .....62

- calibration loop ..... 182  
 calibration of pH sensors ..... 117  
 calibration principle ..... 117  
 calibration window ..... 58  
 canceled ..... 14  
 Canon ..... 29  
 capacity ..... 19; 226  
 carat ..... 28  
 card battery ..... 6; 19  
 card name ..... 19  
 carrying out a determination ..... 80  
**CASE** ..... 196; 197  
 CASE sequences ..... 195  
 CASE with input lines ..... 198  
 Centronics ..... 4; 29; 45  
 changer ..... 49; 51; 87; 184  
 changer address ..... 184  
 character attributes ..... 36; 278  
 character sequences ..... 203  
 character string ..... 205  
 chemically inhibited reactions  
     ..... 134; 150  
 CIBA ..... 181  
 clear working area ..... 275  
 clearing up memory ..... 257  
 clockwise ..... 185  
 closing moves ..... 191  
 CM ..... 122  
**CMOVE(..)CMOVE** ..... 90  
 code ..... 41  
 codepage 850 ..... 279  
 COM1/2 ..... 33  
 command line ..... 75  
 command reference ..... 128  
 command report ..... 68  
 command sequence ..... 68; 205  
 comment ..... 130; 173; 179  
 common variables ..... 119; 120; 270  
 commun. mode ..... 46  
 communication commands  
     ..... 203; 206  
 communication functions ..... 200  
 communication Int. .... 46  
 communication interface .. 77; 204  
 compatibel ..... 30  
 compensation curve ..... 118  
 concentr. .... 130; 192  
 concentration ..... 130  
 conditioning ..... 155; 168; 209  
 conditioning beaker ..... 187  
 conditioning flag ..... 155  
 conditioning mode ..... 109  
 conditioning volume ..... 155  
 conditions ..... 195  
 configuration ..... 34  
 configuration files ..... 37  
 configuration of  
     sample changers ..... 38  
 configuration report ..... 68  
 confirm ..... 208  
 conformity ..... 294  
 connecting a balance ..... 27  
 connection cable ..... 32; 33  
 connections ..... 22  
 constant volume increments... 104  
 continue a sample series ..... 81  
 contrast ..... 34  
 control characters ..... 28; 204  
 control difference ..... 107  
 control direction ..... 156  
 control range ..... 152; 165  
 correct the pH ..... 134  
 counterclockwise ..... 185  
 course of a sample series ..... 90  
 COV ..... 122; 155; 169  
 CR ..... 204  
 create new method ..... 72  
 creating a key card ..... 276  
 cross-wires cursor ..... 221  
 ct ..... 28; 121; 134; 151; 174  
**CTRL\_RM** ..... 32; 202  
**CTRL\_RSx** ..... 204  
 current method ..... 98  
 cursor keys ..... 15  
 curve ..... 211  
 curve display... 142; 148; 167; 178  
 curve presentation .. 219; 223; 225  
 curves ..... 219  
 custom ..... 61; 181  
 custom adjustments ..... 152; 165  
 CV ..... 122  
 cycles ..... 51  
  
**D**  
 d(rel) ..... 285  
 DATA ..... 35  
 data acceptance ..... 97  
 data acquisition ..... 176; 177  
 data bits ..... 45  
 data card ..... 5; 228  
 data card handling ..... 19  
 data card preparation ..... 19  
 data card report ..... 68  
 data communication ..... 200  
 data communication settings ... 45  
 data input ..... 97  
 data memory ..... 257  
 data output ..... 97  
 data storage ..... 36  
 data transfer from balances .... 92  
 data transfer protocol ..... 36  
 data transmission mode ..... 46  
 data transmission protocol .... 229  
 date ..... 35  
 DD ..... 85; 121  
 dec ..... 120  
 decimal exponent ..... 122  
 decimal logarithm ..... 122  
 decimal places ..... 120  
 declaration of conformity ..... 293  
 default ..... 49; 51  
 DELAY ..... 8  
 delay period ..... 161  
 delete sample silo ..... 93  
 deletion ..... 14  
 derivation ..... 152; 163  
 destination ..... 82; 87  
**DET** ..... 129  
 determ.name ..... 82; 83  
 determination data ..... 86  
 determination date ..... 35  
 determination duration ..... 85  
 determination files ..... 35; 36; 85  
 determination report ..... 69; 75; 79  
 determination run ..... 80  
 determination termination ..... 80  
 determination time ..... 35  
 determinations ..... 80  
 Devices & Manual control ..... 53  
 diagnosis ..... 260  
 dialog ..... 11  
 dialog in ..... 34  
 dialog overview ..... 11  
 dialog page ..... 210  
 diameter ..... 47; 49  
 differential amplification ..... 26  
 differential potentiometry ..... 26  
 DIN ..... 181  
 DIP-switch ..... 30  
 direction ..... 150; 156; 161; 169  
 direction of rotation ..... 44  
 display ..... 186  
 display contrast ..... 9  
 display of live value ..... 162  
 disposable beaker ..... 39  
 division ..... 143; 224  
 dMV/dt ..... 125; 224  
 dMV/dV ..... 125; 224  
 DOD ..... 122; 159  
 dos. drive ..... 131; 192; 195  
 dos. rate ..... 133; 160; 193  
 dosing commands ..... 192  
 dosing device functions ..... 55  
 dosing devices ..... 23; 47; 53; 54  
 dosing drives ..... 296  
 dosing port ..... 23  
 dosing rate ..... 50; 51; 133;  
     ..... 138; 160  
 dosing speed ..... 48; 50; 193  
 dosing tip ..... 49  
 dosing tube ..... 49  
 Dosino ..... 296  
 Dosino port ..... 23  
 double determinations ..... 91  
 DRC ..... 122; 155; 169  
 drift ..... 154; 166  
 drift control ..... 60; 138; 146  
 drift volume reduction ..... 155; 169  
 drift-controlled measurement . 118  
 drift-controlled measurement  
     acceptance ..... 115  
 dV/dt ..... 125; 224  
 dwt ..... 28  
 dynamic equivalence point titra-  
     tion ..... 101  
 dynamics ..... 152; 165  
  
**E**  
 earth ..... 24  
 earthing ..... 18  
 EBus address ..... 24  
 EBus chain ..... 24  
 ddit ..... 14  
 ddit beep ..... 34  
 ddit direction ..... 96  
 edit mode ..... 14; 15; 34; 96  
 edit ..... 274  
 editing keys ..... 8; 9  
 EF# ..... 121  
 eject button ..... 20  
 eject the page ..... 67  
 electrical insulation ..... 290  
 electricity supplies ..... 21  
 electrode input ..... 26  
 electrode slope ..... 282  
 electrode system voltage ..... 117  
 electrodes ..... 26; 297  
 electromagnetic compatibility. 291  
 electrostatic charges ..... 20  
 EM# ..... 121

- EMC .....291  
**EMPTY** ..... 47; 48; 55; 195  
empty .....55  
emptying .....195  
enable auto FF ..... 46; 126  
**END** command .....80  
end marker .....211  
end of determination .....200  
end of the method .....211  
end-point ..... 150; 156; 162; 170  
endpoint conditioning .....109  
endpoint titration .....107  
english .....34  
entry field ..... 14; 15  
entry values .....14  
EP criterion .....147  
EP recognition ..... 102; 105;  
..... 139; 146  
EP window ..... 102; 105  
EP# ..... 121; 136  
EP# from .....141  
EPC .....147  
EPC [ ] ..... 141; 147  
EPs .....221  
Epson ..... 29; 30; 45  
Epson 60\*72 .....45  
Epson 80\*60 .....45  
Epson LX-300 .....29  
equibr.time ..... 60; 138; 146;  
..... 174; 175; 180  
equibr.time auto .....60  
equilibrium titration .....101  
equivalence point .....136  
equivalence point criterion .....139  
equivalence point recognition  
criterion ..... 102; 105  
equivalence points ..... 140; 221  
ERC ..... 102; 139  
error ..... 200; 204  
error beep .....34  
error messages .....231  
evaluation area .....140  
evaluation range ..... 102; 105  
examples .....14  
exchange units .....47  
**EXIT** ..... 196; 197  
exotic buffers .....181  
EXP() .....122  
expert .....35  
expiry date of the battery .....6  
extended measuring functions  
.....115  
external bus ..... 24; 289  
external printer .....29  
external pumps .....201  
extract. time .....161  
extraordinary sensors .....181
- F**
- F# .....121  
F# M.value .....142  
F1...9 .....142  
factor ..... 132; 135; 160; 164; 194  
factory settings .....257  
failure .....21  
'false' .....123  
fast ..... 134; 150; 162  
FF ..... 77; 126  
FF# .....121  
field cursor .....14
- field type .....37; 97  
FIFO buffer .....230  
file attributes .....217  
file backup .....229  
file comment .....36  
file dialog window .....37; 72; 74  
file list .....226  
file manager .....226  
file name .....35; 82; 83; 86  
file name type .....35  
file operations .....74; 226; 227  
file system .....19; 229  
file transfer protocol .....36  
files .....226  
fill. rate .....136; 157; 164; 170  
filling speed .....48  
filling port .....23  
filling rate .....50; 52; 136  
filling speed .....50; 52  
final form feed .....77; 126  
final result .....120  
Fisher .....181  
fix end points .....142  
fixed .....143; 224  
fixed endpoints .....102; 105  
fixed volume steps .....144  
flag .....271  
flags .....123  
flash cards .....6  
flask .....49  
FM# .....121  
footer .....78  
FORM FEED .....8; 67; 126  
format data card .....19; 228  
formfeed .....76; 125  
formula .....120  
Fortuin .....105  
front view .....3  
FullRes .....69  
FullStat .....125  
function .....186  
function keys .....7; 13  
functional check .....38  
fuse holder .....17  
fuses .....17
- G**
- GDI printers .....29  
gen. lower limit .....140  
gen. upper limit .....140  
general reports .....68  
global common variables .....  
.....69; 271  
GLP .....280; 283  
GLP key .....9  
GLP report .....69  
GLP results .....69  
GN .....28  
Good Laboratory Practice .....283  
grain .....28  
gram .....28  
greatest .....140  
grid .....143; 225
- H**
- half neutralization point...103; 106  
half neutralization potential .....  
.....103; 106  
halide determination .....123  
handshake .....45
- HELP key .....9  
help texts .....9  
help window .....9  
Hewlett-Packard ..... 29; 45  
hide .....273  
high water content .....162  
HNP value ..... 102; 106  
HNP# .....122  
HNPx .....141  
HNV# .....122  
**HOLD** .....208  
HOLD window .....208  
hotkeys .....7  
HP Deskjet .....29; 30  
HP Laserjet .....30  
HP-compatible .....45  
HP-Deskjet .....45
- I**
- I(pol) .....135; 152; 158;  
.....163; 171; 176  
IBM Proprinter ..... 30; 45  
ID1 .....85; 97; 121  
ID2 .....85; 97; 121  
ID3 .....85; 97; 121  
ident. item .....207  
ident1...3 .....95; 207  
IM .....122  
inactive .....32; 198; 202  
increments too small .....108; 113  
Ind A1, A2 .....26  
indicator electrodes .....26  
individual determinations .....81  
individual measurement .....115  
inf .....177  
Ingold .....181  
initial .....134; 151; 162; 174  
initial position .....43  
initialization .....46  
initialize the sample changer ....64  
Initializing the RS232 interfaces...  
.....46  
inkjet printer .....29; 45; 67; 77; 126  
inner diameter .....49  
input .....31  
Input 0...7 .....198; 200  
input lines .....32; 64; 66; 198; 201  
input pointer .....95; 96; 97  
insert mode .....14; 34  
insert paper .....18  
installation .....16  
instructions for sample prepara-  
tion .....81  
instrument description .....3  
instrument diagnosis .....38  
instrument setup .....16  
interface configuration .....44  
interface designation .....4  
interfaces .....37  
intermediate result .....120  
intermediate titration duration .....  
.....156; 169  
internal printer .....46  
internal stirrer .....211  
interrupt a sample series .....81  
interrupt method .....208  
Ion meters .....201  
isotherm .....117  
IT .....121; 134  
ITD .....122; 155; 159; 169

**J**

JEIDA ..... 291

**K**

Karl Fischer conditioning ..... 114  
 Karl Fischer titration ..... 111  
 kermit ..... 36; 229  
 ketones ..... 113  
 key abbreviations ..... 9  
 key card ..... 35; 272; 276  
 key codes ..... 278  
 key combinations ..... 9  
 key simulation ..... 278  
 keyboard ..... 7  
 keyboard blocked ..... 206  
 keyboard buffer ..... 30  
 keyboard codes ..... 279  
 key-code ..... 46  
 keyCTRL ..... 46; 206; 278  
 keySEND ..... 46; 278  
 key-simulation mode ..... 45  
 KF oven ..... 113; 201  
 KF reagents ..... 164  
**KFC** ..... 168  
**KFT** ..... 159  
 KFT back titrations ..... 112  
 kilogram ..... 28  
 kinetic inhibited titration reactions  
     ..... 104

**L**

language ..... 34  
 laser printer ..... 45; 67; 77; 126  
 last ..... 140  
 lb ..... 28  
 LCD contrast ..... 34  
 LCD screen ..... 34  
 length ..... 47; 49  
 LF ..... 204  
**LIFT** ..... 188  
 lift functions ..... 65  
 lift rate ..... 185  
 lift speed ..... 185  
 lift stations ..... 43  
 limited working life ..... 20  
 limits ..... 281; 285  
 limits ..... 280  
 LIMS ..... 33; 45; 46  
 LIMS system ..... 124  
 line cursor ..... 221  
 line distributor ..... 24  
 line feed ..... 67  
 line frequency ..... 288  
 line number ..... 95  
 line status ..... 32  
 line time ..... 208; 210  
 line voltage ..... 288  
 linear regression ..... 118; 286  
 live ..... 121  
 live curve ..... 211  
 live value ..... 162  
 live-parameter ..... 78  
 LN() ..... 122  
 load method ..... 72; 78; 95; 98  
 load methods from ..... 275  
 loading ..... 37  
 local buffer ..... 75  
 local buffer memory ..... 96  
 local common variables ..... 69

locked ..... 54  
 locked keys ..... 273  
 LOG() ..... 122  
 low water content ..... 162  
 low-conductivity media ..... 26

**M**

m ..... 217; 271  
 M. value ..... 125; 224  
 M.pts ..... 221  
 magnetic code ..... 39; 41  
 main ..... 211  
 main page ..... 11  
 mains adapter ..... 29  
 mains cable ..... 18  
 mains connection ..... 17; 18  
 mains on ..... 9  
 mains plug ..... 21  
 mains supply ..... 16  
 mains voltage ..... 16  
 maintenance intervals ..... 280  
 malfunctioning ..... 21  
 MAN CONTROL ..... 7  
 manual dosing ..... 56  
 manual entry ..... 271  
 manual measurements ..... 57  
 manual operation ..... 7; 53; 57  
 manual printing ..... 8  
 mask ..... 35; 36  
 mathematical functions ..... 122  
 matrix printers ..... 45  
 max. rate ..... 153; 166  
 MCurve\_T ..... 124  
 MCurve\_V ..... 124  
 MD ..... 121; 155; 169  
 mean value ..... 85; 285  
**MEAS** ..... 172  
 meas. cycles ..... 177  
 meas. input ..... 131; 173; 180  
 meas. interval ..... 162; 177  
 meas. procedure ..... 176; 177  
 meas.pt.density ..... 137  
 meas.val ..... 133; 136  
 measurement acceptance  
     ..... 60; 174; 180  
 measurement change ..... 60  
 measurement drift ..... 179; 180  
 measurement group ..... 290  
 measurement ranges ..... 290  
 measuring electrodes ..... 26  
 measuring group ..... 57; 66  
 measuring inputs ..... 5; 26  
 measuring interface ..... 5; 26; 66  
 measuring mode ..... 57; 99  
 measuring parameters ..... 60  
 measuring point list ..... 86; 125;  
     ..... 137; 165; 177; 219  
 measuring points ..... 221  
 measuring series ..... 116; 177  
 measuring temperature ..... 57  
 medium ..... 134; 150; 162  
 memories ..... 291  
 memory area ..... 74; 226  
 memory card ..... 19; 291  
 Merck ..... 181  
**MET** ..... 144  
 METHOD ..... 7; 95  
 method editor ..... 71  
 method name ..... 36  
 method report ..... 68

method selection ..... 7  
 methods ..... 71  
 Metrodata 796 PC Backup ..... 229  
 Metrodata VESUV ..... 46  
 Metrohm ..... 181  
 Metrohm (Bkup) ..... 36  
 Metrohm cables ..... 22  
 Metrohm remote language ..... 204  
 Metrohm thermal paper  
     (order no. 6.2237.040) ..... 46  
 Mettler ..... 27; 28  
 Mettler AT ..... 27  
 milligram ..... 28  
 min. EPC ..... 140; 147  
 min. increment ..... 166  
 min. rate ..... 153  
 min.increment ..... 137  
 missing endpoints ..... 123  
 MNC## ..... 85; 121  
 MNR\$\$ ..... 85  
 MNRxx ..... 121  
 MNX\$\$ ..... 85  
 MNXxx ..... 121  
 mode duration ..... 156; 169  
 mode report ..... 68; 69  
 model versions ..... 3  
 modified ..... 217; 271  
 modified data ..... 78; 216  
 modified method ..... 78  
 modified user dialog ..... 272  
 moisture determination ..... 111  
 monitoring ..... 35; 277  
 monotonic equivalence point  
     titration ..... 104  
 move beaker ..... 65  
 move lift ..... 65  
**MOVE\_B** ..... 187  
**MOVE\_S** ..... 186; 187  
 MP\_List ..... 125  
 Mpt. interval ..... 151  
 Mpt. overflow ..... 137; 165  
 multi-curve ..... 124  
 multiple ..... 176; 177  
 multiple cable ..... 33  
 multiple measurement ... 116; 176  
 MV,dMV/dV ..... 125; 224  
 MV,Temp ..... 125  
 MW, Temp ..... 224

**N**

n ..... 217; 271  
 natural logarithm ..... 122  
 navigate ..... 13  
 navigation ..... 7; 8; 9; 15  
 neg ..... 150  
 new ..... 217  
 new lines ..... 93  
 new start ..... 257  
 newly calculated ..... 217  
 NEXT ..... 8  
 next command ..... 80  
 NIST ..... 181  
 no. data records ..... 275  
 no. of samples ..... 275  
 none ..... 181  
**NOOP** ..... 211  
 normal ..... 120  
 Novartis ..... 181  
 n-point calibration ..... 118  
 numeric ..... 97

- numerical ..... 134; 151;  
..... 163; 174; 180
- o ..... 217; 271
- OMOVE(...)** **OMOVE** ..... 90
- on beaker error ..... 186
- on tower ..... 188
- open ..... 273
- opening moves ..... 190
- opening the instrument ..... 21
- operate manually ..... 54
- operator name ..... 77
- operators ..... 122
- options ..... 296
- OR ..... 197
- order number ..... 282
- organic solvents ..... 26
- original ..... 217; 271
- original data ..... 78; 216
- original initialization ..... 257
- original method ..... 78
- other manufacturers ..... 22; 32
- ounce ..... 28
- outlet ..... 49
- output ..... 31
- output 0...7 ..... 200
- output buffer ..... 46
- output lines ..... 32; 202
- output pointer ..... 95; 96; 98
- overlapping curves ..... 222; 223
- overshoot ..... 109; 113
- overwrite mode ..... 14; 34
- oz ..... 28
- P**
- packaging ..... 16
- page ..... 211
- page feed ..... 46; 67; 76;  
..... 77; 125; 126
- page-oriented printers ... 125; 126
- paper transport ..... 18
- parallel Centronics interface .... 29
- parallel interface ..... 45
- parallel port ..... 289
- parallel printer interface ..... 29
- parallel processing ..... 65
- parameter report ..... 124
- parameters for KFC modes .... 169
- parameters for KFT modes ..... 159
- parameters for SEC modes .... 156
- parameters for SET modes ..... 149
- parameters of the DET modes  
..... 131
- parameters of the MET modes  
..... 144
- parity ..... 45
- parity check ..... 45
- password ..... 37; 273
- pattern ..... 201; 203
- pause ..... 133
- pause 1 ..... 161
- pause 2 ..... 161
- PC ..... 45; 229; 278
- PC cards ..... 19
- PCMCIA ..... 6; 19; 291
- pcs ..... 28
- pennyweight ..... 28
- perforation ..... 46
- peripheral device ..... 24
- peripheral device connections .... 4
- peripheral devices ..... 22; 31
- personal computer ..... 36; 45;  
..... 68; 77; 229; 278
- pH correction ..... 151
- pH electrodes ..... 57
- pH measurement ..... 58
- pHAs ..... 61
- picklist ..... 14
- pieces ..... 28
- pin assignment ..... 289
- pK value ..... 102; 106; 141
- pK/HNP evaluation ..... 141
- pointer column ..... 95
- pointers ..... 97
- Pol ..... 26
- polarization current ..... 58; 135;  
..... 152; 163; 176
- polarization voltage ..... 58; 135;  
..... 152; 163; 176
- polarized electrodes ..... 26
- polarizer ..... 290
- pos ..... 150
- position ..... 42
- potential difference ..... 282
- potential jump ..... 150
- potential measurement ..... 58
- potentiometric ..... 26
- potentiometric pH measurement  
..... 115
- potentiometric voltage measure-  
ment ..... 115
- pound ..... 28
- power on ..... 257
- power on PREP warning ..... 36
- power supply ..... 24
- power-up sequence ..... 43; 44
- Precisa ..... 27
- pre-dose ..... 131
- PREP** ..... 47; 48; 55; 194
- prepare ..... 36
- prepare' ..... 55
- preset endpoint ..... 107
- print ..... 67; 77; 125; 206
- print out text line ..... 206
- print re-evaluations ..... 69
- printer ..... 29; 45
- printer cable ..... 29
- printer connector ..... 289
- printer interface ..... 29
- printer menu ..... 67
- printer offline ..... 46
- printer port ..... 45
- printscreen ..... 9
- protocol ..... 45
- Pt100/1000 ..... 26; 58
- Pt100/Pt1000 ..... 60
- pump ..... 43; 189
- Q**
- quantity ..... 223
- quantity X\_Axis ..... 143; 224
- quantity Y\_Axis ..... 142; 148; 167
- R**
- rack ..... 87
- rack code ..... 41
- rack file ..... 41
- rack name ..... 40; 184
- rack position ..... 42
- rack rotation ..... 187
- rack table ..... 37
- rack type ..... 41
- Radiom. .... 181
- RAM initialization ..... 257
- range of applications ..... 1
- rate ..... 193
- RawData ..... 125
- RE ..... 121; 284; 286
- ready ..... 200; 204
- reagent ..... 54; 130; 192
- reagent bottle ..... 49
- reagent check ..... 54; 84; 192
- reagent control ..... 130
- rear view ..... 4
- recalculation ..... 215
- receive ..... 230
- receive mode ..... 45; 203
- reception buffer ..... 46
- re-evaluation ..... 214; 225
- Ref ..... 26
- reference electrode ..... 26
- reformatting ..... 228
- reject ..... 14
- relative ..... 132; 160
- relative slope ..... 117
- relative stop volume ..... 164
- REM** ..... 210
- remark ..... 36; 120
- remote ..... 64; 66; 201; 202
- remote connection ..... 200
- remote control ... 36; 46; 206; 278
- remote functions ..... 200
- remote interface ..... 31; 288
- remote socket ..... 31
- remote terminal mode ..... 36
- report header ..... 37
- reports ..... 124
- reproducibility ..... 283
- request user name ..... 276
- RESET\_C** ..... 190
- response time ..... 282
- rest position ..... 43
- RESULT ..... 7; 211
- result report ..... 69; 124
- results ..... 213
- results columns ..... 217
- results page ..... 213
- results report ..... 76
- rinse ..... 40
- rinsing a sensor ..... 190
- rinsing beaker ..... 187
- rinsing cycles ..... 51
- rinsing position ..... 40; 188
- rinsing pump ..... 189
- rinsing the tubings ..... 47
- rinsing volume ..... 51
- rotational speed ..... 185
- RS 232 interface ..... 97; 203
- RS 232C ..... 288
- RT1 ..... 121; 284; 285
- RT2 ..... 121; 284
- run number ..... 35; 82
- run variable ..... 186
- Rxx ..... 121
- S**
- safety information ..... 21
- SamplData ..... 124
- SAMPLE** ..... 7; 186
- sample changer ..... 25; 63; 275
- sample changer commands .. 184

- sample counter ..... 186  
 sample data ..... 83; 92; 124; 207  
 sample data entry ..... 92  
 sample data report ..... 69; 76  
 sample identification ..... 28; 35;  
     ..... 36; 85; 97; 207  
 sample identification fields ..... 37  
 sample identifiers ..... 95  
 sample input ..... 7  
 sample number ..... 85  
 sample pos. .... 87; 89; 186  
 sample rack ..... 39  
 sample rack ..... 65  
 sample racks ..... 297  
 sample remark ..... 36; 208  
 sample series ..... 82; 83; 87  
 sample silo ..... 69; 92; 97; 274  
 sample silo configuration ..... 96  
 sample silo report ..... 69  
 sample size ..... 85; 95  
 sample to tower ..... 187  
 sample vessel ..... 39  
 sample weight ..... 28; 83; 97  
 sampling time ..... 176  
 Sartorius ..... 27; 28  
 save data to ..... 275  
 scale ..... 143; 224  
 scale divisions ..... 224  
 scale parameters ..... 224  
 scaling parameters ..... 143  
**SCAN\_RM** ..... 32; 201  
**SCAN\_RSx** ..... 205  
 scope of delivery ..... 295  
 screen contents ..... 9; 36; 67  
 screen off ..... 34  
 screen save ..... 34  
 SD ..... 121  
**SEC** ..... 155  
 selection ..... 184; 190  
 selection mask ..... 228  
 send ..... 77; 126; 230  
 sensor ..... 130  
 sensor check ..... 57  
 sensor control ..... 130  
 sensor list ..... 281  
 sensor test ..... 9; 280  
 sensors ..... 26; 53; 57  
 sensors A/B ..... 26  
 serial number ..... 4  
 serial RS 232 interface ..... 29  
 serial/parallel converter ..... 29  
 series of samples ..... 190; 191  
 service ..... 280  
 service data ..... 280  
 service department ..... 21  
**SET** ..... 149  
 setting the RS232 interfaces ..... 45  
 shift ..... 40  
 shift direction ..... 185  
 shift position ..... 40; 64; 65; 188  
 shift rate ..... 185  
**SHOW** ..... 210  
 show method window ..... 275  
 ShrtRes ..... 69  
 ShrtStat ..... 125  
 signal ..... 31  
 signal drift ..... 60; 138; 146;  
     ..... 173; 179  
 signal impulses ..... 201  
 signal leads ..... 31  
 signature line ..... 77  
 silo ..... 87  
 silo file ..... 95  
 silo input pointer ..... 88  
 silo line ..... 88; 95  
 simple calibration ..... 179  
 single ..... 185  
 single curves ..... 219  
 size ..... 95; 132; 135; 160; 164; 208  
**SKIP** ..... 8  
 SL ..... 122; 179  
 slope ..... 61; 117; 133; 282  
 slow ..... 134; 150; 162  
 slow moisture release ..... 162  
 SM ..... 122  
 softkey bar ..... 7; 14; 96; 273; 276  
 softkeys ..... 7; 13  
 SOP ..... 283  
 spec. .... 41  
 spec. beaker ..... 42  
 special beakers ..... 41; 42; 187; 188  
 special characters ..... 10; 74  
 special input unit ..... 28  
 special positions ..... 40; 41; 188  
 special racks ..... 37  
 special wiring ..... 33  
 specification ..... 125  
 SQRT() ..... 122  
 square root ..... 122  
 SRAM cards ..... 6; 19; 228  
 SS ..... 85; 92; 121  
 S-shaped curves ..... 101  
 ST ..... 121; 134; 151; 174  
 standard ..... 35; 176; 177  
 standard deviation ..... 285  
 standard file name ..... 35  
 standard measurement ..... 115; 175  
 standard operating procedures  
     ..... 283  
 standard rack ..... 39  
 standard report ..... 76; 124; 127  
 standard text ..... 35  
 standard tubing parameters ..... 49  
 start ..... 200; 204  
 start conditions ..... 131; 160  
 start val. .... 177  
 start volume ..... 160  
 stat. .... 91; 121  
 state ..... 189  
 state1 ..... 198  
 state2 ..... 198  
 stateA ..... 198  
 static electricity ..... 21  
 statist. .... 216  
 statistical data ..... 216  
 statistical data report ..... 76  
 statistical report ..... 69  
 statistical results ..... 69  
 statistics ..... 82; 85; 87; 216; 275  
 statistics counter ..... 76; 85  
 statistics data report ..... 125  
 statistics 'ini' ..... 89  
 statistics results ..... 216  
 statistics window ..... 216  
 STATUS ..... 7  
 Status definitions ..... 68; 276  
 status information ..... 7  
 status messages ..... 28  
 status settings ..... 272  
 status window ..... 82  
**STIR\_C** ..... 189  
**STIR\_I** ..... 211  
 stirrer connection ..... 26; 66; 289  
 stirrer power supply ..... 26  
 stirring rate ..... 190  
 stop ..... 200; 204  
 stop bits ..... 45  
 stop conditions ..... 135; 163  
 stop crit. .... 154; 166  
 stop criteria ..... 135; 154  
 stop drift ..... 154; 167  
 STOP PRINT ..... 8; 67  
 stop time ..... 136; 165  
 stop val. .... 178  
 stop volume ..... 135; 164  
 storage errors ..... 257  
 stored files ..... 68  
 storing ..... 37  
 streaming potential ..... 282  
 substitution term ..... 123  
 SV ..... 122; 132; 160  
 swing head ..... 39; 43  
 switch on ..... 24; 36  
 switch-off criteria ..... 108; 112  
 switch-on ..... 43  
 system components ..... 22  
 system date ..... 35  
 system time ..... 35; 209  
 system validation ..... 280; 283  
 system variables ..... 85; 121; 215  
 systematic deviation ..... 285  
 systematic error ..... 285  
**T**  
 t(delay) ..... 154; 167  
 T\_Curve ..... 124  
 TAN/TBN determinations ..... 102  
 target endpoint ..... 150; 156; 162  
 technical specifications ..... 288  
 temp. .... 125; 224  
 temperature ..... 60; 134; 151; 157;  
     ..... 162; 171; 174; 180  
 temperature correction ..... 58; 181  
 temperature measurement  
     ..... 58; 115  
 temperature sensor ..... 26  
 terminal program ..... 229  
 terminal program ..... 36  
 terminal remote control mode  
     ..... 278  
 terminal software ..... 278  
 test function TST( , ) ..... 123  
 test intervall ..... 282  
 test plug ..... 260  
 text ..... 97  
 thermal paper ..... 18; 46  
 thermal printer ..... 6; 46; 67; 289  
 threshold value ..... 139  
 time ..... 35; 154; 166; 224  
 time axis ..... 151; 163  
 time curve ..... 124  
 time out ..... 46  
 time recording ..... 135; 151; 163  
 time-controlled measurement. 118  
 time-controlled measurement  
     acceptance ..... 115  
 tip 49  
 titr. rate ..... 137; 145  
 titrating beaker ..... 39

- titration conditions..... 134; 150;  
     ..... 156; 161; 169  
 titration curves.....219  
 titration head .....297  
 titration mode.....99  
 titration parameters.....137  
 titration rate ..... 137; 145  
 titration speed .....153  
 titration system.....283  
 titration time too long .....109  
 titration to a preset endpoint...107  
 titrimetric water determination.159  
 to position .....188  
 to tower .....188  
 tower 1/2 max. height.....43  
 tower 1/2 Pump[s] .....43  
 trace window.....13  
 transmission parameters .....229  
 transmission speed.....45  
 transmit key-codes.....46  
 troubleshooting .....231  
 troy ounce .....28  
 'true'.....123  
 TST( , ) .....122  
 TTL-level.....31  
 tubing..... 47; 194; 195  
 tubing dimensions . 38; 47; 49; 51  
 turntable.....185  
 two-point calibration.....59  
 two-tower operation .....64  
 type..... 41; 49; 50; 51; 76;  
     ..... 120; 124; 181  
  
 type of buret unit.....47  
  
**U**  
 U(pol) .....135; 152; 158;  
     .....163; 171; 176  
 unit .....28; 95; 120  
 unmodified .....217  
 upgrade set 6.5855.000 .....26  
 user .....276  
 user adjustments .....137; 145  
 user dialog .....11; 272  
 user level.....35  
 user-defined buffer types.....61  
 user-defined racks .....39  
  
**V**  
 V\_Curve .....124  
 vacuum in the cylinder .....50; 52  
 validating .....9  
 validation.....280  
 Validation interval.....286  
 validation results .....285; 287  
 value .....187  
 value [pH] .....181  
 verification of a calibration .....118  
 versions.....3  
 VESUV .....46; 124; 126  
 viscous liquids .....164  
 viscous reagent solutions .50; 52;  
     .....133; 138; 193  
 voltage selector.....16  
  
 voltametric measurement .....  
     .....115; 176  
 voltametric titration . 135; 152; 163  
 Volume.....51; 125; 132; 135;  
     .....160; 164; 193; 224  
 volume curve .....124; 127  
 volume increment .....166  
 volume steps .....145  
  
**W**  
 WAIT .....208  
 WAIT window .....209  
 WAIT\_C .....110; 114; 168; 209  
 WAIT\_T .....209  
 warranty .....292  
 weight .....83  
 window.....140  
 windows.....141  
 work .....40  
 work position .....40; 188  
  
**X**  
 Xxx .....121  
  
**Y**  
 Y-axis .....142; 148  
  
**Z**  
 zero point .....282