



Ion analysis

CH-9101 Herisau/Switzerland

E-Mail info@metrohm.ch

Internet www.metrohm.ch

Metrohm Sample Processors

789 Robotic Sample Processor XL
778 Sample Processor

Technical Reference

Program versions 5.7xx.0022

Table of Content

1	The Metrohm Remote Control Language	1
1.1	General rules	1
1.2	Call up of objects	2
1.3	Triggers.....	3
1.4	Status messages	4
1.5	Detailed status conditions	4
1.6	Error messages	5
2	The remote control tree	10
2.1	Overview	10
2.2	&Mode – Method parameters	11
2.3	&Configuration	13
2.4	&Info - Instrument data	16
2.5	&Setup - Instrument setup.....	18
2.6	&UserMeth - User defined methods.....	20
2.7	&Assembly - Instrument components	21
2.8	&Diagnose - Instrument diagnosis	24
3	Properties of the RS 232 Interface	25
3.1	Data Transfer Protocol.....	25
3.2	Handshake.....	26
3.3	Pin Assignment	29
3.4	What can you do if data transfer fails?	31
4	The Metrohm Remote Interface.....	32
4.1	Pin assignation of the Remote interface	32
4.1.1	The Remote socket	34
4.1.2	Standard allocation of remote lines in Metrohm measuring and titration instruments:.....	35
4.1.3	The standard Remote lines	36
4.1.4	Wiring of the Metrohm Standard Remote cable	37

5	Technical specifications.....	38
5.1	Keypad.....	38
5.2	Interfaces.....	38
5.3	MSB Connections.....	38
5.4	Pumps and pump connectors.....	38
5.4.1	Built-in pumps and valves.....	38
5.4.2	Pump connectors.....	39
5.5	Swing Head connector.....	39
5.6	Lift.....	39
5.7	Turntable.....	39
5.8	Stirrer connectors.....	39
5.9	Mains connection.....	39
5.10	Safety specifications.....	39
5.11	Electromagnetic Compatibility (EMC).....	39
5.12	Temperatures.....	40
5.13	Dimensions and material.....	40

1 The Metrohm Remote Control Language

1.1 General rules

Metrohm instruments have an extensive remote control facility that allows full control of the instrument via the RS 232 interface, i.e. the instrument can receive data from an external controller or send data to an external controller. C_R and L_F are used as terminators for the data transfer. The instrument sends $2xC_R$ and L_F as termination of a data block, to differentiate between a data line which has C_R and L_F as terminators. The controller terminates its commands with C_R and L_F . If more than one command per line is sent by the controller, “;” is used as a separator between the individual commands.

The data are grouped logically and easy to understand. Thus e.g., for the selection of the dialog language, the following must be sent

&Config.Aux.Language "english"

whereby it is sufficient to only transmit the boldface characters, thus:

&C.A.L "english"

The quantities of the commands above are:

C onfig	configuration data
A ux	auxiliaries, various data
L anguage	setting the dialog language

The data are hierarchically structured (tree form). The quantities that occur in this tree are called **objects** in the following. The dialog language is an object which can be called up with the

&Config.Aux.Language command.

If one is in the desired location in the tree, the value of the object can be queried.

&Config.Aux.Language \$Q Q means Query

The query command \$Q initiates the issuing of the value on the instrument and the value emission is triggered. Entries which start with \$, trigger something. They are thus called **triggers**.

Values of objects can not only be queried, they can also be modified. Values are always entered in quotes, for example:

&Config.Aux.Language "english"

1.2 Call up of objects

An excerpt from the object tree is represented below:

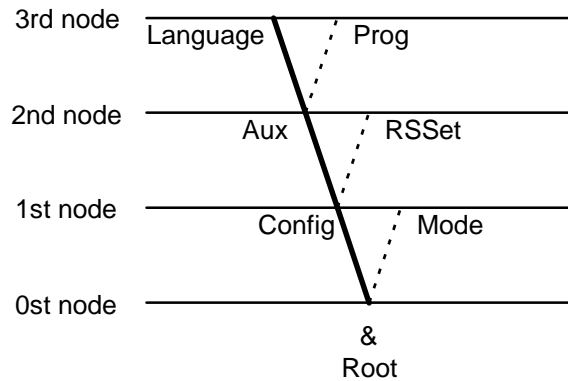

Rules	Example
<p>The root of the tree is designated by &.</p> <p>The branches (levels) of a tree are marked with a dot (.) when calling up an object.</p> <p>When calling up an object, it is sufficient to give only as many letters as necessary to uniquely assign the object. If the call is not unequivocal, the first object in the series will be recognized.</p> <p>Upper- or lowercase letters may be used.</p> <p>An object can be assigned a value. Values are signified at the beginning and end by quotes ("). They may contain up to 24 ASCII characters.</p> <p>Numerical values can contain up to 6 digits, a negative sign, and a decimal point. Numbers with more than 6 characters are not accepted; more than 4 decimal places are rounded off. For numbers <1, it is necessary to enter leading zeros.</p> <p>The current object remains until a new object is called.</p> <p>New objects can be addressed relative to the old object: A preceding dot leads forwards to the next level in the tree.</p> <p>More than one preceding dot leads one level backwards in the tree. n node backwards require n+1 preceding dots.</p> <p>If you must jump back to the root, enter a preceding &.</p>	<p>Calling up the dialog language &Config.Aux.Language or &C.A.L</p> <p>&C.A.L or &c.a.l Entering the dialog language: &C.A.L"english" correct entry of numbers: "0.1" incorrect entry of numbers "1,5" or "+3" or ".1"</p> <p>entry of another dialog language: "deutsch" From the root to node 'Aux': &C.A Forward from node 'Aux' to 'Prog': .P</p> <p>Jump from node 'Prog' to node 'Aux' and select a new object 'Language' at this level: ..L</p> <p>Change from node 'Language' via the root to node 'Mode': &M</p>

1.3 Triggers

Triggers initiate an action on the instrument, for example, starting a process or sending data. Triggers are marked by the introductory symbol \$.

The following triggers are possible:

\$G	G o	Starts processes, for ex. starting the mode run or setting the RS 232 interface parameters
\$S	S top	Stops processes
\$H	H old	Holds processes
\$C	C ontinue	Continues processes after Hold
\$Q	Q uery	Queries all information from the current node in the tree forward up to and including the values
\$Q.P	P ath	Queries the path from the root of the tree up to the current node
\$Q.H	H ighest Index	Queries the number of son nodes of the current node
\$Q.N"i"	N ame	Queries the name of the son node with index i, $i = 1 - n$
\$D	D etail-Info	Queries the detailed status information
\$U	q Uit	Aborts the data flow of the instrument, for example, after \$Q

The triggers \$G and \$S are linked to particular objects, see the summary table.

All other triggers can be used at any time and at all locations on the object tree.

Examples:

Querying the value of the baud rate: **&C**onfig.**RS**Set.**B**aud **\$Q**

Querying all values of the node "RSSet": **&C**onfig.**RS**Set **\$Q**

Querying the path of the node "RSSet": **&C**onfig.**RS**Set **\$Q.P**

Start mode: **&M**ode **\$G**

Querying the detailed status: **\$D**

1.4 Status messages

In order to have an efficient control by an external control device, it must also be possible to query status conditions; they provide information on the status of the instrument. The trigger \$D initiates output of the status. Status messages consist of the global status, the detailed status and eventual error messages, e.g. \$\$Mode.SET;E26. The global status informs on the activity of the process, while the detailed status conditions show the exact activity within the process.

The following **global status conditions** are possible:

\$G Go:	The instrument is executing the last command.
\$H Hold:	The instrument has been held (\$H, key <meas/hold> or by an error which effects the hold status)
\$C Continue:	The instrument has been restarted actively after hold
\$R Ready:	The instrument has executed the last command and is ready
\$S Stop:	A process has been aborted in an "unnatural manner". e.g. stopped or aborted because there was an error.

1.5 Detailed status conditions

Status conditions of the global \$G:

(Example: Liquino, XDOS mode)

\$G.Mode.XDOS .Inac:	instrument at the beginning or at the end of a mode.
.Run:	instrument in the XDOS mode, running.
\$G.Assembly.Fill:	Buret in filling process
\$G.Assembly.Prep:	Preparing a dosing unit
\$G.Assembly.Empty:	Emptying a dosing unit

Manual modes:

\$G.Manual.DOSING	Manual dosing
\$R.Manual.DIS	Manual distribution

Status conditions of the global \$H:

The status message of the action which has been held appears.

Status conditions of the global \$C:

The status conditions of the global \$C are identical with the ones of the global status \$G. They appear when the process has been restarted actively from the status "Hold" (\$C, key <CONTINUE/HOLD> or automatically after elimination of an error).

Status conditions of the global \$R:

\$R.Mode.XXXX.Inac: instrument in the XXXX mode, inactive.

Status conditions of the global \$S:

\$S.Mode.XXXX.Inac: The instrument gives the status from which it has been stopped. The detailed status information is therefore identical to those of the global status \$G.

1.6 Error messages

Error messages are added to the status messages and separated from them by the sign ";".

This list of error messages applies to all instruments provided with the Metrohm remote control language.

E1	Incorrect program check sum
E2	RAM read/write error
E3	RAM lost data (battery)
E4	Timer interrupt for multi-tasking is missing
E5	RS232 module test error
E6	Defective real time clock or defective EBUS or RS232 read/write error
E7	Display read/write error
E8	Card read/write error. Exit: Send new command.
E9	Wrong card, i.e. memory card from an other instrument or card has been removed/inserted during the inquiry. Exit: Replace card and send new command.
E10	The card has lost data. Exit: Replace card and end new command.
E11	EEPROM Error
E12	EBUS Error Slave 1. Set address switch correctly!
E13	EBUS Error Slave 2
E14	Remote Box communication error
E18	Card battery low (it is between 2.37...2.64 V). Exit: Send new command. Change battery.
E19	Faulty RAM test
E20	Check exchange unit. Exit: Mount Exchange Unit (properly) or &m \$\$.
E21	Check electrode, short circuit. Replace electrode if necessary. Exit: Rectify fault or &m \$\$.
E22	Check electrode, break. See above. Exit: Rectify fault or &m \$\$.
E23	Division by zero. Exit: The error message disappears on next startup or on recalculation.
E24	Check drive unit. Exit: Connect drive unit (correctly) or &m \$\$.
E26	Manual stop. Exit: The error message disappears on next startup.
E27	Stop V reached in SET, STAT, DOS or DOC. Exit: The error message disappears on next startup.
E28	Wrong object call up Exit: Send correct path for object. Start path at root.
E29	Wrong value or no value allowed. Exit: Send correct value or call up new object.

- E30** Wrong trigger, this trigger is not allowed or carrying-out of action not possible.
Exit: Send correct trigger (exception: \$D) or call up new object.
- E31** Command is not possible in active status. Repeat command in inactive status.
Exit: Send new command.
- E32** Command is not possible during titration. Repeat command during the conditioning phase or in inactive status.
Exit: Send new command.
- E33** Value has been corrected automatically.
Exit: Send new command.
- E34** instrument at the end of the titration and sample data is edited; the instrument at rest or editing during filling.
Exit: &m \$S.
- RS receive errors:**
- E36** Parity
Exit: <QUIT> and ensure settings of appropriate parameters at both devices are the same.
- E37** Framing error
Exit: <QUIT> and ensure settings of appropriate parameters at both devices are the same.
- E38** Overrun error. At least 1 character could not be read.
Exit: <QUIT>
- E39** The internal working-off buffer of the instrument is full (>82 characters).
Exit: <QUIT>
- RS send errors:**
- E40** DSR = OFF, no proper handshake for more than 1 s
- E41** DCD = ON, is the receiver switched on and ready to receive?
- E42** CTS=OFF, no proper handshake for more than 1 s.
Exit: <QUIT> Is the receiver switched on and ready to receive?
- E43** The transmission of the instrument has been interrupted with XOFF for at least 6 s.
Exit: Send XON or <QUIT>
- E44** The RS parameters are no longer the same for both devices
- E45** The receive buffer of the instrument contains an incomplete command (L_F missing). Sending from the instrument is therefore blocked.
Exit: Send L_F or <QUIT>.
- E120** Overrange of the primary measured value (pH, U, I_{pol}, U_{pol} or T with MEAS T). The secondary measured value (temperature) may be instable as well.
Exit: Correct error or &m \$S.
- E121** Measuring point list overflow (more than 500 measuring points).
Exit: The error message disappears on next startup.

E122	EP overflow. Exit: The error message disappears on next startup or on recalculation.
E123	Missing EP for calculation. Exit: The error message disappears on next startup or on recalculation.
E124	Number of EP does not correspond with the set windows. Exit: The error message disappears on next startup or on recalculation.
E125	Missing fix EP for calculation, has not been defined. Exit: The error message disappears on next startup or on recalculation.
E126	Fix-EP outside of measuring point list. Exit: The error message disappears on next startup or on recalculation.
E128	No new mean. Exit: The error message disappears on next startup or on recalculation.
E129	No new common variable, old value remains. Exit: The error message disappears on next startup or on recalculation.
E130	Wrong sample. For SET, KFT or DOC with preset titration direction the first measured value lies behind the endpoint. Exit: The error message disappears on next startup.
E131	No EP set for SET, STAT. Exit: The error message disappears on next startup.
E132	Silo empty and it has been started with open silo or empty silo has been opened. Exit: Send a silo entry.
E133	Silo full. Exit: Send new command.
E134	No method. A method, which is required from the silo memory or in TIP, does not exist. Exit: The error message disappears on next startup.
E135	Check temp.sensor in MEAS T or with activated temperature monitoring. Temp. sensor may not be connected. Exit: Correct error or &m \$\$.
E136	Same buffer in CAL. Measured value of the second buffer differs less than 6 mV from the measured value of the first buffer. Exit: Rectify error or &m \$\$.
E137	XXX Bytes are missing so that the method, the silo line could not be stored or not enough RAM for running TIP. Exit: Send new command.
E149	Rate missing for calculation. Exit: The error message disappears on next start or on recalculation.
E150	Number of rates does not agree with the set windows or the mean rate C80 could not be calculated. Exit: The error message disappears on next start or on recalculation.
E151	Fix volume missing for calculation. Exit: The error message disappears on next startup or on recalculation.

E155	No new silo result (C24 or C25). Exit: The error message disappears on next start or on recalculation.
E157	No sequence defined in TIP. Exit: The error message disappears on next start.
E158	A second TIP has been called up in TIP. Exit: The error message disappears on next start.
E160	No new temporary variable. Exit: The error message disappears on next start.
E161	Measurement range of the secondary measured value (temperature) exceeded. The primary measured value (pH, U, Ipol, Upol) can also be unstable. Exit: Rectify error or &m \$\$.
E162	No ramp end set in DOC. Exit: The error message disappears on next start or &m \$\$.
E166	Save lines is "OFF" although a submethod of TIP includes an assignment to C24 or C25. Exit: The error message disappears on next start. Attention: The data of this sample will not be stored.
E167	Rate too high in DOS. No dispensing possible with the Exchange Unit currently mounted. Exit: The error message disappears on next start or &m \$\$.
E170	Fix time missing for calculation. Exit: The error message disappears on next start or on recalculation.
E171	Rate too low in DOS. No dispensing possible with the Exchange Unit currently mounted. Exit: The error message disappears on next start or &m \$\$.
E172	In TIP or DOS a QuickMeas was started, without defining a measuring quantity. Exit: The error message disappears on next start or &Mode.QuickMeas \$\$.
E173	The warning interval of the internal buret D0 called. Exit: Execute prep &a.b.p \$G or start next method.
E174	The warning interval of the external buret D1 called. Exit: Execute prep &a.b.p \$G or start next method.
E175	The warning interval of the external buret D2 called. Exit: Execute prep &a.b.p \$G or start next method.
E176	The function &Assembly.Buret.Prepare or &Assembly.Buret.Empty was interrupted manually. Exit: The error message disappears on next start.
E177	Accessing to the memory card, the card was not (properly) inserted. Exit: The error message disappears on next start.
E178	The date of changing the battery of the card is expired. Exit: The error message disappears on next start.
E180	Memory card write-protected. Exit: Send new command.
E181	Memory card not formatted. Exit: Send new command.
E182	Memory card not accessible. Exit: Send new command.

E183	A directory with the same name exists already on the memory card. Exit: Send new command.
E184	Measured value below lower limit. Exit: The error message disappears when again within the limits or &m \$S.
E185	Measured value above upper limit. Exit: The error message disappears when again within the limits or &m \$S.
E186	Temperature below lower limit. Exit: The error message disappears when again within the limits or &m \$S.
E187	Temperature above upper limit. Exit: The error message disappears when again within the limits or &m \$S.
E188	Rate below lower limit. Exit: The error message disappears when within the limits or &m \$S.
E189	Rate above upper limit. Exit: The error message disappears when within the limits or &m \$S.
E190	Add Water
E191	Blank error
E192	Generator electrode
E193	Indicator electrode
E194	Sample unfit
E195	Water R
E196	Result out of limits
E197	Weighing out of limits
E198	Validation interval exceeded
E199	Service date reached
E200	Invalid instrument adjustment (default value)
E201	Function error of Sample Changer/Processor
E202	Function error of dosing drive
E203	No oven temperature
E204	No external dosing unit
E205	Calibration interval expired
E206	Gas flow too high
E207	Error list full
E208	Timeout reached
E209	Instrument temperature too high (>60°C)
E210	Check Pt sensor
E211	Short circuit on Pt 100/1000
E212	Remote-Box transfer error
E213	Remote-Box keyboard timeout
E214	Remote-Box, check parameter

2 The remote control tree

2.1 Overview

The remote control tree contains the following main branches:

&	Root
. <u>M</u> ode	Method parameters
. <u>C</u> onfig	Instrument configuration
. <u>I</u> nf o	Current data
. <u>S</u> etup	Instrument setup
. <u>U</u> serMeth	User-defined methods
. <u>A</u> ssembly	Instrument components
. <u>D</u> iagnosis	Instrument diagnosis

The following tables list all objects of the remote control tree. For the unambiguous designation of the objects, the underlined characters suffice. The meaning of the individual object is described here in brief, for more detailed information please refer to 'Instructions for use'. The default values of the objects are printed in boldface.

Changer		
. <u>RackName</u>	Rack name, forces the use of the defined rack with the current method (blank = any rack).	blank , 10 ASCII characters
. <u>L1Rate</u>	Lift rate of tower 1 (in mm/second)	5... 25 mm/s
. <u>L2Rate</u>	Lift rate of tower 2 (in mm/second)	5... 25 mm/s
. <u>ShRate</u>	Shift rate of the rack in angular degrees/sec	3... 20 °/s
. <u>ShDir</u>	Shift direction of the rack (ascending or descending rack positions; auto. means automatic choice of the shortest path)	+, -, auto
. <u>Rotincr</u>	Rotation increment for MOVE +/-rotate	0.00... 5.00 ...270.00°
. <u>Sw1Rate</u>	Swing head 1 rate in angular degrees/sec	10... 55 °/s
. <u>Sw2Rate</u>	Swing head 2 rate in angular degrees/sec	10... 55 °/s
. <u>Swincr</u>	Swing increment for MOVE +/-swing	0.00... 10.00 ...180.00°
. <u>ModeSample</u>	Reaction on missing sample beaker. (MOVE = next sample beaker will be chosen regarding the recent SAMPLE command, display = display warning.)	MOVE , display
StirRates		
. <u>T1</u>	Rate of stirrer on tower 1	1... 3 ...15
. <u>T2</u>	Rate of stirrer on tower 2	1... 3 ...15
. <u>MSB1</u>	Rate of MSB stirrer 1	1... 3 ...15
. <u>MSB2</u>	Rate of MSB stirrer 2	1... 3 ...15
. <u>MSB3</u>	Rate of MSB stirrer 3	1... 3 ...15
DosimatSet		
. <u>DosUnitNo</u>	Dosing drive address	1 ...3
. <u>1</u>	Drive selector	
. <u>DosRate</u>	Dosing rate	0.01...160 ml/min, max.
. <u>FillRate</u>	Filing rate	0.01...160 ml/min, max.
. <u>DosTube</u>	Dosing outlet 1	1 ...4
. <u>DosTube2</u>	Dosing outlet 2	1 ...4
. <u>FillTube</u>	Filling inlet	1... 2 ...4
. <u>ExchTube</u>	Rinsing inlet on exchanging buret unit	1... 2 ...4
. <u>PrepTube</u>	Dosing outlet in preparing cycle	1 ...4
. <u>EmptyTube</u>	Air inlet for emptying	1... 4
. <u>CockMove</u>	Cock direction of Dosino auto = shortest path for cock rotation asc/desc = fixed cock rotation direction not over = cock will not rotate over protected port	auto , asc., desc., not over
. <u>NotOver</u>	Dosino port to be protected	1... 4
. <u>3</u>	up to dosing drive 3	
TimeoutSet		
. <u>STime</u>	SCAN Timeout in min.	0...999, off
. <u>SAction</u>	Action after timeout	error , cont.
ManStop		
. <u>RemCtl</u>	Remote command	STOP device1, STOP device2, STOP device*, 14 x 1,0 or * (bin)
. <u>RSCtl</u>	Command via RS232 interface	&M;\$S, 14 ASCII characters
. <u>Pumps</u>	Pumps states	on, off, cont.
. <u>StirT1</u>	Stirrer of tower 1	on, off, cont.

.StirT2	Stirrer of tower 2	on, off, cont.
.StirMSB1	MSB Stirrer 1	on, off, cont.
.StirMSB2	MSB Stirrer 2	on, off, cont.
.StirMSB3	MSB Stirrer 3	on, off, cont.

2.3 & Configuration

Object	Meaning	Entry range/Selection
&Config		
Aux		
.Language	Dialog language	english ; deutsch; francais; español
.Contrast	Display contrast	0..3..7
.Beeper	Beeper	off; on
.ExtStart	Enable external Remote start	off ; on
TimeMeter		
.Elapsed	Working hours elapsed	read only
.Warning	Time limit	off , 1...99999 h
.DevName	Device label	8 ASCII characters
.Prog	Program version	5.778.011 (read only)
.AutoReset	En/Disable rack reset on 'Start'	off; on
.Raminit	Raminit on 'Power on'	off ; on
Tower1		
.MaxLift	Maximum stroke path	0... 235 ...325 mm
.BeakRad	Min. required beaker radius	1.0...100.0 mm, *
Swing head settings of tower 1		
.RinsePos	Lift position for rinsing in ext. position	0 ...325 mm
.SwingPos	Lowest lift position for moving the swing head	0 ...325 mm
.Ext1Pos	Swing angle for external position 1	0... 84.00 ...(max. angle, see p. Fehler! Textmarke nicht definiert.)
.Ext1Height	Working lift height of ext. position 1	0 ...325 mm
.Ext2Pos	Swing angle for external position 2	0... 84.00 ...(max. angle)
.Ext2Height	Working lift height of ext. position 2	0 ...325 mm
.Ext3Pos	Swing angle for external position 3	0... 84.00 ...(max. angle)
.Ext3Height	Working lift height of ext. position 3	0 ...325 mm
.Ext4Pos	Swing angle for external position 4	0... 84.00 ...(max. angle)
.Ext4Height	Working lift height of ext. position 4	0 ...325 mm
Tower2		
.MaxLift	Maximum stroke path	0... 235 ...325 mm
.BeakRad	Min. required beaker radius	1.0...100.0 mm, *
Swing head settings of tower 2		
.RinsePos	Lift position for rinsing in ext. position	0 ...325 mm
.SwingPos	Lowest lift position for moving the swing head	0 ...325 mm
.Ext1Pos	Swing angle for external position 1	0... 84.00 ...(max. angle, see p. Fehler! Textmarke nicht definiert.)
.Ext1Height	Working lift height of ext. position 1	0 ...325 mm
.Ext2Pos	Swing angle for external position 2	0... 84.00 ...(max. angle)
.Ext2Height	Working lift height of ext. position 2	0 ...325 mm
.Ext3Pos	Swing angle for external position 3	0... 84.00 ...(max. angle)
.Ext3Height	Working lift height of ext. position 3	0 ...325 mm
.Ext4Pos	Swing angle for external position 4	0... 84.00 ...(max. angle)
.Ext4Height	Working lift height of ext. position 4	0 ...325 mm

RackDef	Rack definitions	
RecallRack	Load rack definitions	\$G
.Name	Rack name	6.2041.310,.....
*		
.Code	Rack code	000001 (b)...111111(b)
.WorkT1	Working lift height at tower 1	0 ...325 mm
.WorkT2	Working lift height at tower 2	0 ...325 mm
.RinseT1	Rinsing lift height at tower 1	0 ...325 mm
.RinseT2	Rinsing lift height at tower 2	0 ...325 mm
.ShiftHT1	Shifting lift height at tower 1	0 ...325 mm
.ShiftHT2	Shifting lift height at tower 2	0 ...325 mm
.Special1	Special lift position at tower 1	0 ...325 mm
.Special2	Special lift position at tower 1	0 ...325 mm
.BeakRad	Beaker radius of sample positions	1.0...100.0, * * means no check
.Sensor	Type of beaker sensor	Tower , SwingH, none
.Offset	Rotational offset	0 ...±5.00°
PosTab	Rack position table	
.Num	Number of rack positions	1 ...999
1	Rack position 1	
.Angle	Rotation angle for rack position 1	0 ...359.90°
.Radius	Rack radius for rack position 1	0 ...250.00 mm
:		
999	Rack position 999	
.Angle	Rotation angle for rack position 999	0 ...359.90°
.Radius	Rack radius for rack position 999	0 ...250.00 mm
:		
SpezBeak	Special beakers	
.SpezBeakNo	Special beaker number	1 ...16
1	Special beaker 1	
.Pos	Rack position	0 ...number of rack positions
.WorkT1	Working lift height for tower 1	0 ...325 mm
.WorkT2	Working lift height for tower 2	0 ...325 mm
.BeakRad	Actual beaker radius	1.0...100.0, * * means no check
.Sensor	Beaker sensor type	Tower , SwingH, none
16	Special beaker 16	
.Pos		
.WorkT1	Working lift height for tower 1	0 ...325 mm
.WorkT2	Working lift height for tower 2	0 ...325 mm
.BeakRad	Actual beaker radius	1.0...100.0, * * means no check
.Sensor	Beaker sensor type	Tower , SwingH, none
:		
StoreRack	Save rack definition	\$G
.Name	Rack name	10 ASCII characters
DeleteRack	Delete rack definition	\$G
.Name	Rack name	10 ASCII characters
DelAll	Delete all rack definitions	\$G
List	List of available rack definitions	
1	Rack 1 ...	
.Name	Rack name	10 ASCII characters
.Bytes	Size of rack table	read only
:		
32	... rack 32	
.Name	Rack name	10 ASCII characters

L.Bytes	Size of rack table	read only
.WetPart	Buret definitions	
F.WetPartNo	Selection of buret unit	1 ...3
* 1	Settings of port 1	
L.MaxRate	Maximum feeding rate	0.01... 160 mL/min
L.Length	Tube length	0... 1000 ...30000 mm
L.Diameter	Tube diameter	0... 2 ...20 mm
2	Settings of port 2	
L.MaxRate	Maximum feeding rate	0.01... 160 mL/min
L.Length	Tube length	0... 250 ...30000 mm
L.Diameter	Tube diameter	0... 2 ...20 mm
3	Settings of port 3	
L.MaxRate	Maximum feeding rate	0.01... 160 mL/min
L.Length	Tube length	0 ...30000 mm
L.Diameter	Tube diameter	0... 2 ...20 mm
4	Settings of port 2	
L.MaxRate	Maximum feeding rate	0.01... 160 mL/min
L.Length	Tube length	0 ...30000 mm
L.Diameter	Tube diameter	0... 2 ...20 mm
.RSset	Settings of the RS232 interface	\$G
.Baud	Baud rate	19200; 9600 ; 4800; 2400; 1200; 600; 300
.DataBit	Data bits	7; 8
.StopBit	Stop bits	1 ; 2
.Parity	Parity	even; odd; none
.Handsh	Handshake	HWS ; SWchar; SWline; none
.CharSet	External printer definition	IBM ; Epson; Seiko; Citizen; HP DeskJ

2.4 &Info - Instrument data

Object	Meaning	Entry range/Selection
&Info		
.Report	Report output	\$G
.Select	Report selection	config ; usermeth; param; all
.ActualInfo	Actual data	
.Lift	Actual data of lift stations 1 and 2	
.1	Lift 1	
.Exist	Availability of lift	yes; no
.MaxHeight	Maximum stroke path	0...325 mm
.ActHeight	Current lift position	0...325 mm
.Beaker	Presence of a beaker at tower sensor	yes, no
.ActPos	Rack position at lift 1	0...999
.Angle	Current rotation angle of the rack	0...359.90°
.Rackkoord	Coordinates of current rack position	
.Angle	Rotation angle	0...359.90°
.Radius	Radius of rack position	0...250 mm
.SwingHead	Swing head data	
.Exist	Availability of swing head 1	yes, no
.Angle	Current swing angle	0...270.0°
.Beaker	Presence of a beaker at swing head sensor	yes, no
.2	Lift 2	
.Exist	Availability of lift	yes; no
.MaxHeight	Maximum stroke path	0...325 mm
.ActHeight	Current lift position	0...325 mm
.Beaker	Presence of a beaker at tower sensor	yes, no
.ActPos	Rack position at lift 2	1...999
.Angle	Current rotation angle of the rack	0...359.90°
.Rackkoord	Coordinates of current rack position	
.Angle	Rotation angle	0...359.90°
.Radius	Radius of rack position	0...200 mm
.SwingHead	Swing head data	
.Exist	Availability of swing head 1	yes, no
.Angle	Current swing angle	0...270.0°
.Beaker	Presence of a beaker at swing head sensor	yes, no
.Rack	Current rack data	
.Code	Rack code	000000...111111
.Name	Rack name	10 characters
.Stirrer	Current stirrer data	
.T1	Stirrer on tower 1	
.Rate	Stirring rate	0...15
.State	Stirrer status	on, off
.T2	Stirrer on tower 2	
.Rate	Stirring rate	0...15
.State	Stirrer status	on, off
.MSB1	MSB stirrer 1	
.Type	Type of stirrer	0, 801, 804, ...
.Rate	Stirring rate	0...15
.State	Stirrer status	on, off
.MSB2	MSB stirrer 2	
.Type	Type of stirrer	0, 801, 804, ...
.Rate	Stirring rate	0...15

.State	Stirrer status	on, off
.MSB3	MSB stirrer 3	
.Type	Type of stirrer	0, 801, 804, ...
.Rate	Stirring rate	0...15
.State	Stirrer status	on, off
.Pump	Current pump states	
.1	Pump 1	
.State	Pump status	on, off
.2	Pump 2	
.State	Pump status	on, off
.3	Pump 3	
.State	Pump status	on, off
.4	Pump 4	
.State	Pump status	on, off
.Buret	Buret data	
.1	Dosing drive DOS1	
.State	Drive status	ready, busy, none
.Position	Current piston position	0...50.0 mL
.Cock	Current cock position	1...4
.Type	Type of dosing device	685, 700, 800, 805
.Volume	Nominal cylinder volume	1 mL, ..., 50 mL
.2	Dosing drive DOS2	
.State	Drive status	ready, busy, none
.Position	Current piston position	0...50.0 mL
.Cock	Current cock position	1...4
.Type	Type of dosing device	685, 700, 800, 805
.Volume	Nominal cylinder volume	1 mL, ..., 50 mL
.3	Dosing drive DOS3	
.State	Drive status	ready, busy, none
.Position	Current piston position	0...50.0 mL
.Cock	Current cock position	1...4
.Type	Type of dosing device	685, 700, 800, 805
.Volume	Nominal cylinder volume	1 mL, ..., 50 mL
.Inputs	Remote interface data	
.Status	Status of input lines	0...255
.Outputs	Remote interface data	
.Status	Status of the output lines	0...255
.Display	Display content	
.L1	Display line 1	24 ASCII characters
.L2	Display line 2	24 ASCII characters
.Counter	Sequence counter	
.Sample	Current sample	0...1000
.Maximum	Number of samples to be processed	0...1000

2.5 &Setup - Instrument setup

Object	Meaning	Entry range/Selection																																																																				
&Setup																																																																						
. <u>I</u> dReport	Report identification	on ; off																																																																				
. <u>K</u> eycode	Sending of key codes	on; off																																																																				
<table border="1"> <thead> <tr> <th>Code</th> <th>Key</th> <th>Code</th> <th>Key</th> </tr> </thead> <tbody> <tr><td>1</td><td><HOLD / LEARN></td><td>16</td><td><7 / SAMPLE></td></tr> <tr><td>2</td><td><STOP></td><td>17</td><td><4 / PUMP></td></tr> <tr><td>3</td><td><START></td><td>18</td><td><1 / SCAN></td></tr> <tr><td>4</td><td><CONFIG></td><td>19</td><td><0 / DEF></td></tr> <tr><td>5</td><td><PARAM></td><td>20</td><td><END></td></tr> <tr><td>6</td><td><USER METHOD></td><td>21</td><td><→></td></tr> <tr><td>7</td><td></td><td>22</td><td><CLEAR / RESET></td></tr> <tr><td>8</td><td><9 / LIFT></td><td>23</td><td><ENTER></td></tr> <tr><td>9</td><td><6 / DOS></td><td>24</td><td><↑></td></tr> <tr><td>10</td><td><3 / WAIT></td><td>25</td><td><↓></td></tr> <tr><td>11</td><td><* / RACK></td><td>26</td><td><SELECT / TOWER></td></tr> <tr><td>12</td><td><8 / MOVE></td><td>27</td><td><QUIT></td></tr> <tr><td>13</td><td><5 / STIR></td><td>28</td><td><HOME></td></tr> <tr><td>14</td><td><2 / CTRL></td><td>29</td><td><←></td></tr> <tr><td>15</td><td><. / PRINT></td><td>30</td><td><INSERT></td></tr> <tr><td></td><td></td><td>31</td><td><DELETE></td></tr> </tbody> </table>			Code	Key	Code	Key	1	<HOLD / LEARN>	16	<7 / SAMPLE>	2	<STOP>	17	<4 / PUMP>	3	<START>	18	<1 / SCAN>	4	<CONFIG>	19	<0 / DEF>	5	<PARAM>	20	<END>	6	<USER METHOD>	21	<→>	7		22	<CLEAR / RESET>	8	<9 / LIFT>	23	<ENTER>	9	<6 / DOS>	24	<↑>	10	<3 / WAIT>	25	<↓>	11	<* / RACK>	26	<SELECT / TOWER>	12	<8 / MOVE>	27	<QUIT>	13	<5 / STIR>	28	<HOME>	14	<2 / CTRL>	29	<←>	15	<. / PRINT>	30	<INSERT>			31	<DELETE>
Code	Key	Code	Key																																																																			
1	<HOLD / LEARN>	16	<7 / SAMPLE>																																																																			
2	<STOP>	17	<4 / PUMP>																																																																			
3	<START>	18	<1 / SCAN>																																																																			
4	<CONFIG>	19	<0 / DEF>																																																																			
5	<PARAM>	20	<END>																																																																			
6	<USER METHOD>	21	<→>																																																																			
7		22	<CLEAR / RESET>																																																																			
8	<9 / LIFT>	23	<ENTER>																																																																			
9	<6 / DOS>	24	<↑>																																																																			
10	<3 / WAIT>	25	<↓>																																																																			
11	<* / RACK>	26	<SELECT / TOWER>																																																																			
12	<8 / MOVE>	27	<QUIT>																																																																			
13	<5 / STIR>	28	<HOME>																																																																			
14	<2 / CTRL>	29	<←>																																																																			
15	<. / PRINT>	30	<INSERT>																																																																			
		31	<DELETE>																																																																			
Sending format of path info																																																																						
. <u>T</u> ree	Short format of path info	on; off																																																																				
. <u>T</u> race	Message output on changed values	on; off																																																																				
Locking of key functions																																																																						
. <u>L</u> ock	Lock all keys	on; off																																																																				
. <u>K</u> eyboard	Lock <CONFIG> key	on; off																																																																				
. <u>C</u> onfig	Lock <PARAM> key	on; off																																																																				
. <u>P</u> arameter	User method functions																																																																					
. <u>U</u> serMeth	Lock method loading	on; off																																																																				
. <u>R</u> ecall	Lock method storing	on; off																																																																				
. <u>S</u> to	Lock method deletion	on; off																																																																				
. <u>D</u> el	Lock display function	on; off																																																																				
. <u>D</u> isplay																																																																						
Changer setup																																																																						
. <u>C</u> hangerSetup	Settings of Swing head 1																																																																					
. <u>S</u> wingH1	Axial distance (Swing head — rack)	100... 166.0 ...300.00 mm (196.0*)																																																																				
. <u>D</u> istance	Swing angle offset	-270.00... 0.00 ...270.00°																																																																				
. <u>O</u> ffset	Maximum swing angle	0... 85 ...330.00°																																																																				
. <u>M</u> axAngle	Swing head length	30.00... 110.00 ...300.00 mm																																																																				
. <u>R</u> adius	Rotation angle offset	-270.00... 0 ...270.00°																																																																				
. <u>R</u> otOffset	Swing direction / mounting of swing head	+ , -																																																																				
. <u>S</u> wingDir																																																																						
Adjustment settings of Swing head 1																																																																						
. <u>S</u> h1adjustment	Type of Swing head	read only																																																																				
. <u>S</u> wingheadNo	Serial number of Swing head	read only																																																																				
. <u>S</u> erialNo	Adjustment angle in positive direction	read only																																																																				
. <u>A</u> nglePos	Adjustment angle in negative direction	read only																																																																				
. <u>A</u> ngleNeg																																																																						

2.6 &UserMeth - User defined methods

Object	Meaning	Entry range/Selection
&UserMeth		
File operations		
.FreeMem	Memory available	read only
.Recall	Loading of methods	\$G
.Name	Method name	8 ASCII characters
.Store	Saving of methods	\$G
.Name	Method name	8 ASCII characters
.Delete	Deleting of methods	\$G
.Name	Method name	8 ASCII characters
.DelAll	Deleting of all methods	\$G
.List	List of stored methods	
1		
.Name	Method name	read only
.Mode	Mode	read only
.Bytes	Method size in bytes	read only
.Checksum	Checksum of method	read only
x	up to x methods, depending on memory available	
.Name
.Checksum

Remark on file operations

First set the file names (node: .Name), then send the trigger \$G for the corresponding function:.

Example: Loading a method

```
&U.R.N"Chloride"
&U.R;$G
```

2.7 &Assembly - Instrument components

Object	Meaning	Entry range/Selection
&Assembly		
└ Sample	Sample control	\$G
└└ Func	Selection of function	=, +, -
└└ Value	Value of function	1...999
└ Move	Rack and Swing head movement	\$G, \$S, \$H, \$C
└└ Target	Lift selection	1, 2
└└ Position	Beaker or Swing head position	sample , ext.1...4, next, prev. spec1...16, +swing, -swing, +rotate, -rotate, -999...1...+999,
└ Rotat	Turntable control	\$G, \$S, \$H, \$C
└└ Tower	Tower selection	1, 2
└└ Angle	Rotation angle	0...359.99°
└ Swing	Swing head control	\$G, \$S, \$H, \$C
└└ Tower	Address / tower of Swing head	1, 2
└└ Angle	Swing angle	-45.00...0...270.00°
└ Lift	Lift control	\$G, \$S, \$H, \$C
└└ Station	Lift selection	1, 2, *
└└ Way	Target lift position	work , shift, rest, special, rinse, 0 mm...max. lift path
└ Stir	Stirrer control	\$G, \$S
└└ Address	Stirrer selection	T1, T2, T*, MSB1,MSB2, MSB3, MSB*, *
└└ Value	Time or status	1...9999 s, on, off
└ Pump	Pump control	\$G, \$S
└└ Address	Pump selection	1.1, 1.2, 1.*, 2.1, 2.2, 2.*
└└ Value	Time or status	1...999 s, on , off
└ Dos	Dosing functions	\$G, \$S, \$H, \$C
└└ Address	Drive and port selection	1.*, ... 3.4, *.*
└└ Value	Dispensing volume or dosing function	±0.001...1...999.999 mL, fill, release, prepar., empty, eject, endVol, compen.,port
└ Scan	Scanning of interfaces	\$G, \$S
└└ Address	Interface selection	Rm , RS
└└ Pattern	Signal pattern or data string	<u>Remote interface:</u> 8 x 1,0 or * (binary pattern) Ready1 , Ready2, Ready*, Cond ok, End1, End2, Endmeter, Continue <u>RS 232 interface:</u> 14 ASCII characters, !*R"
└ Ctrl	Interface control	\$G
└└ Address	Interface selection	Rm , RS
└└		

.Pattern	Signal pattern or data string	<p><u>Remote interface:</u> 14 x 1,0 or * (binary) START device1, START device2, START device*, SAMPLE ready, START dos1, START dos2, START dos*, METER mode pH, METER mode T, METER mode U, METER mode I, METER mode C, METER cal pH, METER cal C, METER enter, INIT</p> <p><u>RS 232 interface:</u> 14 ASCII characters, &M;\$G</p>
.Def	Re-definitions of different settings	\$G
.Object	Item selection	STIRRATE , DOSRATE, FILLRATE, COCKMOVE, LIFTRATE, SHIFTRATE, SWINGRATE
.Adress	Component address	<i>depending upon item</i>
.Value	Value / parameter	<i>depending upon item</i>
.Object	Stirring rate	STIRRATE
.Adress	Stirrer address	T1 , T2, T*, MSB1,MSB2, MSB3, MSB*, *
.Value	Rate	1... 3 ...15
.Object	Dosing rate	DOSRATE
.Adress	Dosing drive address	1 ...3
.Value	Rate	0.01...160 ml/min, max.
.Object	Filling rate	FILLRATE
.Adress	Dosing drive address	1 ...3
.Value	Rate	0.01...160 ml/min, max.
.Object	Rotational direction of valve disk	COCKMOVE
.Adress	Dosing drive address	1 ...3
.Value	Direction	auto , not over, desc., asc.
.Object	Lift rate	LIFTRATE
.Adress	Lift address	1 , 2
.Value	Rate	5... 25 mm/s

*.Object	Shifting rate and direction of the rack	SHIFTRATE
.Address	Shifting direction	auto , +, -
.Value	Shifting rate	3... 20 %/s
.Wait	Waiting time	\$G, \$S, \$H, \$C
.Func	Function	PAUSE , RUNTIME
.Time	Time	0... 1 ...9999 s
.Beaker	Beaker test	\$G
.Address	Sensor selection	Tower1 , Tower2, Swing1, Swing2
.Rack	Rack reset	\$G

2.8 &Diagnose - Instrument diagnosis

&Diagnose		
. <u>I</u> nit	RAM initialization	\$G
. <u>S</u> elect	Selection of memory range to initialize	all , param, config, user meth, setup, assembly
. <u>R</u> amTest	RAM integrity test	\$G
. <u>T</u> imeInit	Initialize time meter	\$G
. <u>D</u> efaultsettings	Resets all settings	\$G
. <u>A</u> nglesadjust	Adjustment of Swing angles	\$G
. <u>L</u> cdTest	Display test	\$G, \$S
. <u>C</u> ontrastTest	Display contrast test	\$G, \$S
. <u>K</u> eyTest	Keyboard test	\$G, \$S
. <u>I</u> oTest	Remote socket test	\$G
. <u>R</u> sTest	RS232 interface test	\$G
. <u>M</u> SBTest	MSB bus test	\$G, \$S
. <u>B</u> eeperTest	Beeper test	\$G, \$S
. <u>R</u> ackcodeTest	Rack code test	\$G
. <u>F</u> unctionTest	Detailed instrument function test	\$G
. <u>S</u> imulateKey	Keycode simulation	1..31, see page 18
. <u>F</u> lash	Write Flash-ROM	\$G
. <u>P</u> owerOn	'Power on' simulation	\$G
. <u>I</u> strNo	Instrument number	not accessible via RS232 interface

3 Properties of the RS 232 Interface

3.1 Data Transfer Protocol

Metrohm instruments are configured as DTE (Data Terminal Equipment).

The RS 232 interface has the following technical specifications:

- Data interface according to the RS 232C standard, adjustable transfer parameters, see pages 13ff.
- Max. line length: 512 characters
- Control characters: C_R (ASCII DEC 13)
L_F (ASCII DEC 10)
XON (ASCII DEC 17)
XOFF (ASCII DEC 19)
- Cable length: max. approx. 15 m

Start	7 or 8 Data Bit	Parity Bit	1 or 2 Stop Bit
-------	-----------------	------------	-----------------

Only a shielded data cable (for example, 6.2125.110) may be used to couple Metrohm instruments with foreign devices. The cable shield must be properly grounded on both instruments (pay attention to current loops).

3.2 Handshake

Software-Handshake, SWchar

Handshake inputs on the instrument (CTS) are not checked.
 Handshake outputs (DTR, RTS) are set by the instrument.
 The instrument sends XOFF when its input buffer contains 384 characters. After this it can receive 128 extra characters (including L_F). When the buffer is cleared to 128 characters, XON is sent.

Metrohm instruments as Receiver :

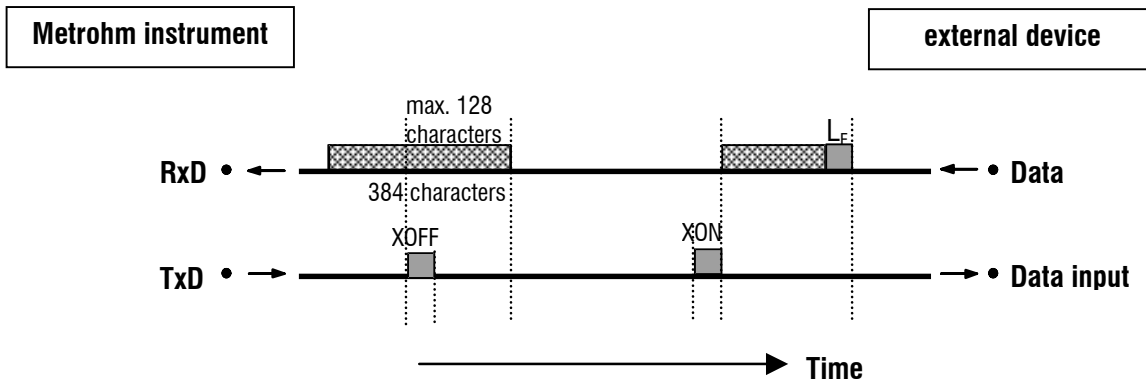

Metrohm instrument as Sender :

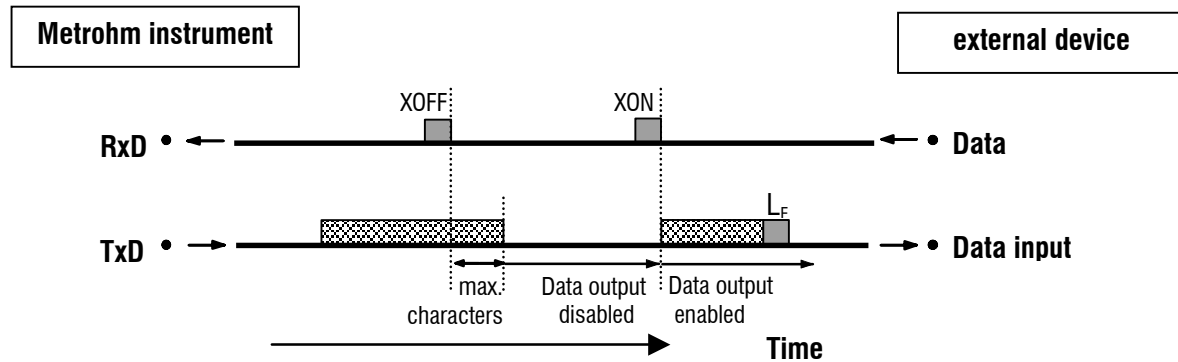

max. characters: 2 characters at 300...9600 baud
 16 characters at ≥ 19200 baud

Software-Handshake, SWline

Handshake input ports on the instrument (CTS) are not checked. Handshake output ports (DTR, RTS) are set by the instrument. The instrument has an input buffer which can accept up to 512 characters.

Metrohm instrument as Receiver :

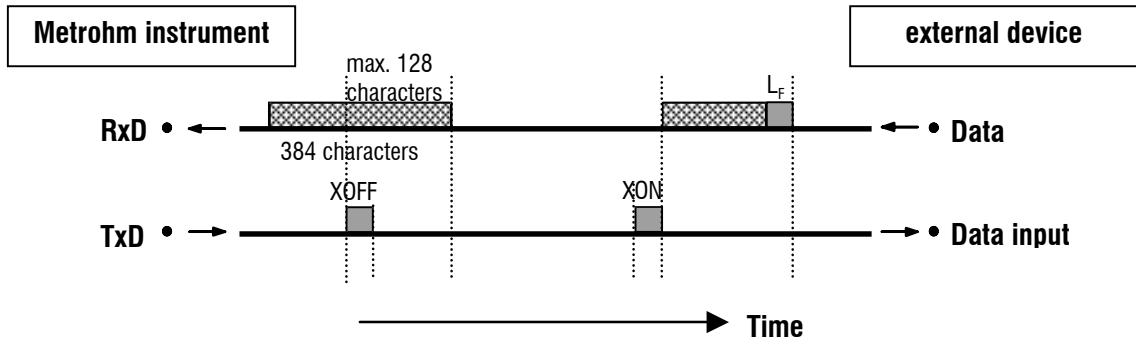

Metrohm instrument as Sender:

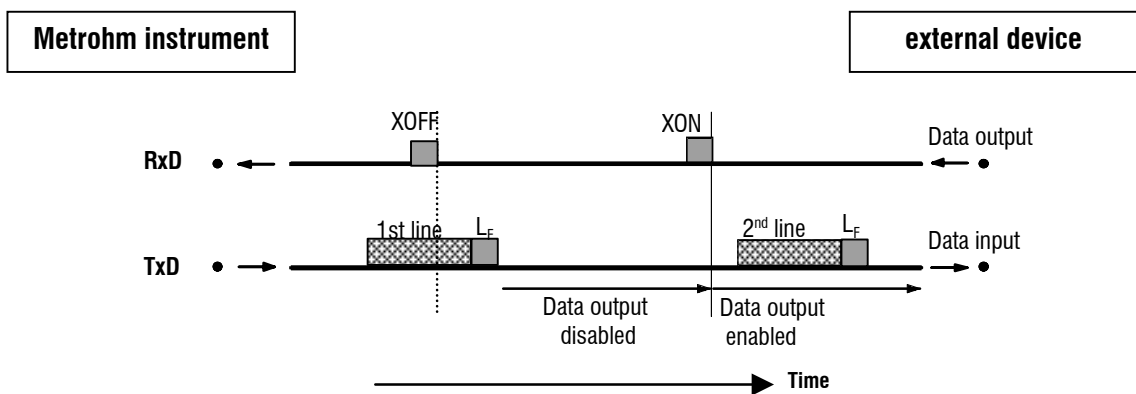

The instrument's transmission can be stopped by external instruments with XOFF. After XOFF is received the instrument completes sending the line already started. If data output is disabled for more than 10 s by XOFF, E43 appears in the display.

Hardware-Handshake, HWs

Metrohm instrument as Receiver :

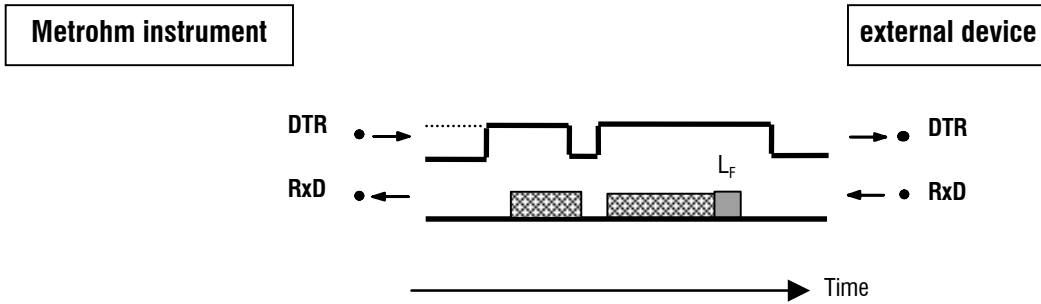

Metrohm instrument as Sender:

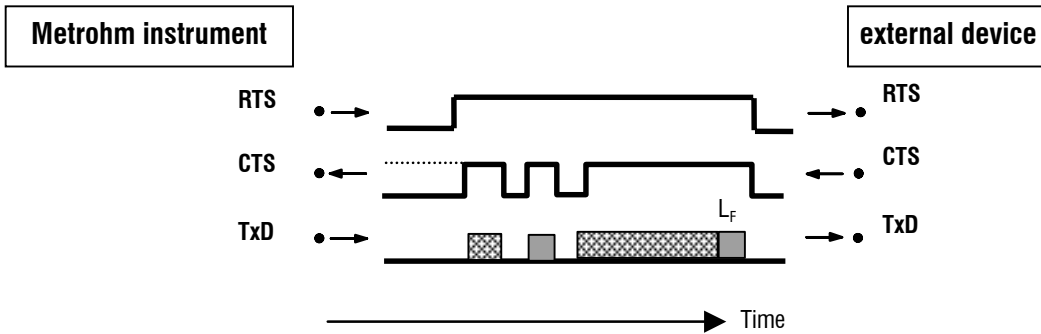

The data flow can be interrupted by deactivating the CTS line.

3.3 Pin Assignment

RS232C Interface

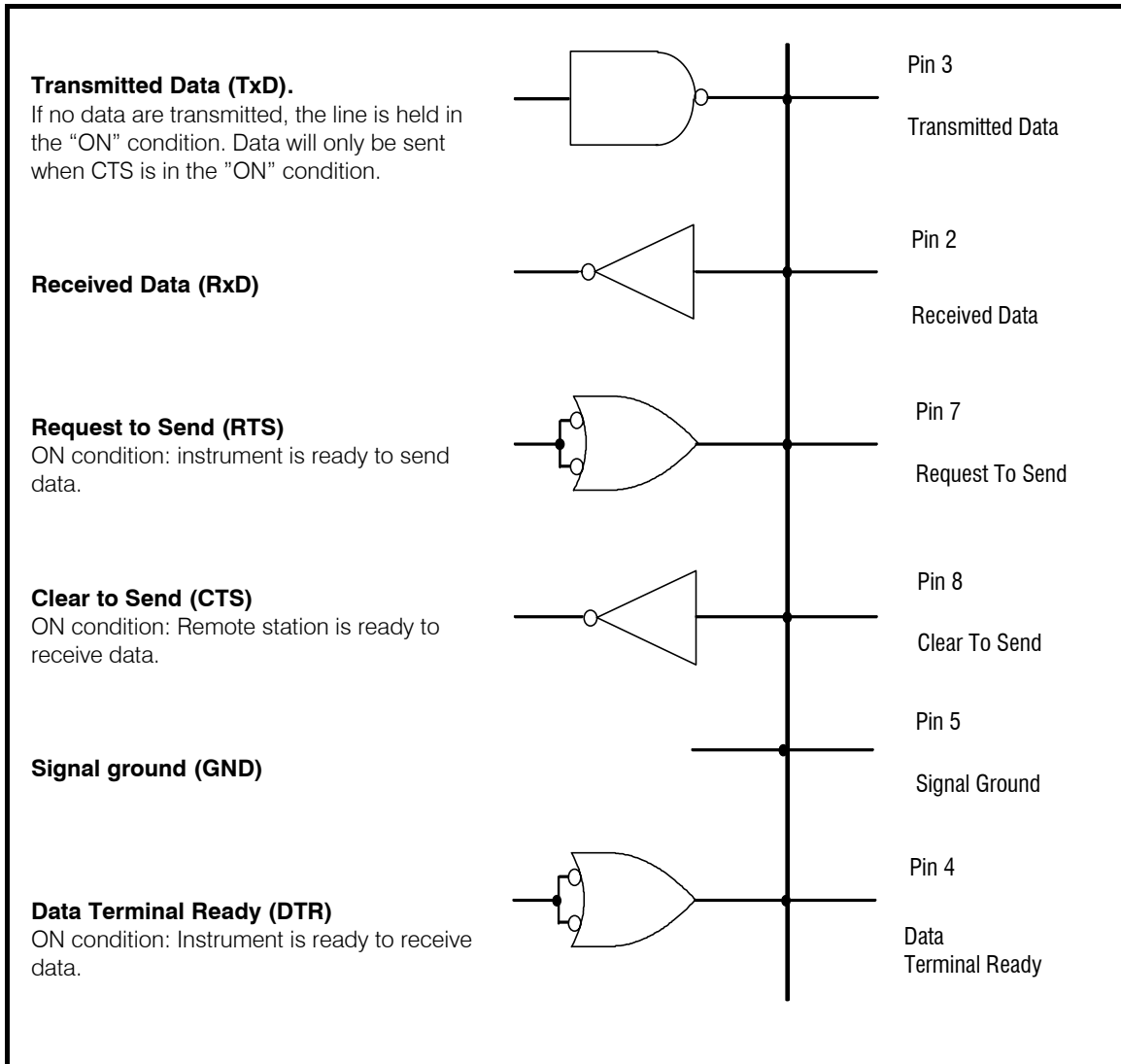

Protective earthing

Direct connection from cable plug to the protective ground of the instrument.

Polarity allocation of the signals

- Data lines (TxD, RxD)
voltage negative (<-3 V): signal state "ON"
voltage positive (> +3 V): signal state "ZERO"
- control or message lines (CTS, RTS, DTR)
voltage negative (<-3 V): OFF state
- voltage positive (> +3 V): ON state

In the transitional range from +3 V to -3 V the signal state is undefined.

Driver 14C88 according to EIA RS 232C specification
Receiver 14C89 " "

Contact arrangement at plug (female) for RS 232C socket (male)

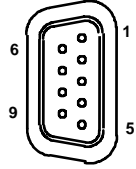

No liability whatsoever will be accepted for damage or injury caused by improper interconnection of instruments.

3.4 What can you do if data transfer fails?

Problem	Questions for remedial action
No characters can be received on a connected printer.	<ul style="list-style-type: none"> - Are the instruments switched on and cables plugged in correctly? - Is the printer set to "on-line"? - Are baud rate, data bit and parity the same on both instruments? - Is the handshake set properly? <p>If everything seems to be OK, try to print a report with the key sequence <PRINT> <ENTER>.</p>
No data transmission and the display of the instrument shows an error message.	<ul style="list-style-type: none"> - error 42: Transmission error. Is the printer set to "on-line"? Is the connection cable properly wired? - error 43: Data output of the instrument disabled for longer than 10 s by XOFF. - error 36-39: Receive error. Are the RS settings the same on both devices?
The received characters are garbled.	<ul style="list-style-type: none"> - Are the RS settings the same on both devices? - Has the correct printer been selected? - Data transfer has been interrupted on the hardware side during the printout of a curve. Re-establish connections and switch printer off/on.
Wrong line spacing.	The printer does not emulate completely the preset mode. Usually these problems arise with the IBM mode. Set the printer to a different mode (e.g. Epson).
Printout of a curve is not ok. Other reports are printed ok.	Handshake is necessary for the printout of curves. <ul style="list-style-type: none"> - Is your cable correctly wired? (The DTR of the printer has to be connected to the CTS of the instrument.) - Set "HWS" for the handshake of the instrument. Configure the printer such that its DTR is set (possibly with DIP switches).

4 The Metrohm Remote Interface

4.1 Pin assignation of the Remote interface

	external	Function
<p>Inputs</p>	<p>pin 21 (Input 0)</p> <p>pin 9 (Input 1)</p> <p>pin 22 (Input 2)</p> <p>pin 10 (Input 3)</p> <p>pin 23 (Input 4)</p> <p>pin 11 (Input 5)</p> <p>pin 24 (Input 6)</p> <p>pin 12 (Input 7)</p>	<p>All input lines may be scanned by the SCAN command.</p> <p>Ready1</p> <p>Cond ok</p> <p>End1</p> <p>Stirrer 780, Continue</p> <p>Ready2</p> <p>external STOP *, End2</p> <p>external START *</p> <p><i>* if external START on</i></p> <p>~50 kΩ Pull up</p>
<p>Voltage</p>	<p>pin 15</p> <p>pin 14</p> <p>pin 25</p>	<p>$I \leq 200 \text{ mA}$</p> <p>0 V: active</p> <p>5 V: inactive</p>

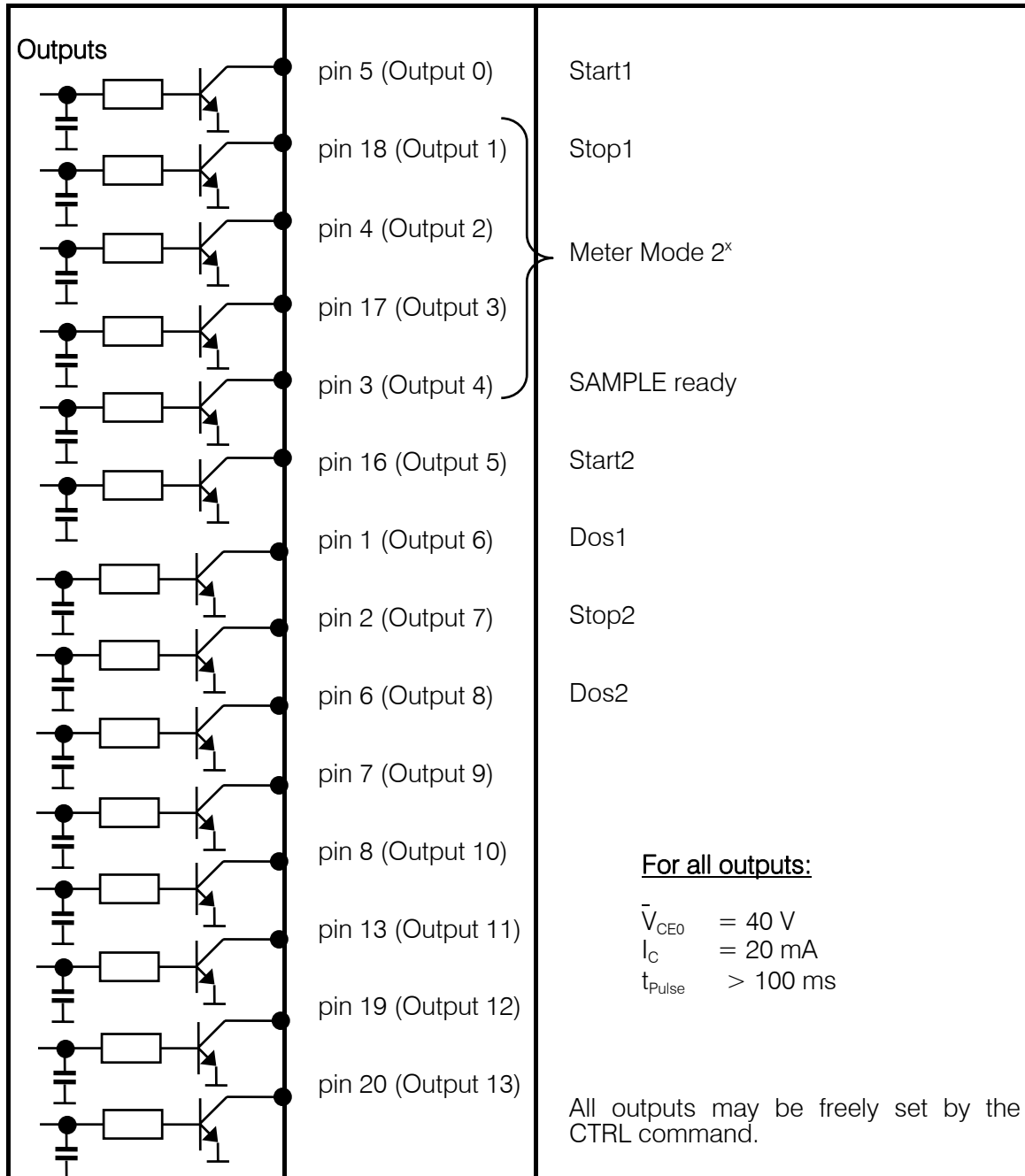

Ordering number for standard Remote cable:
6.2141.020, see Metrohm Accessories Catalog also.

No liability whatsoever will be accepted for damage caused by improper interconnection of instruments.

4.1.1 The Remote socket

The pin assignment of a 25-pin remote plug can be seen from the information given below.

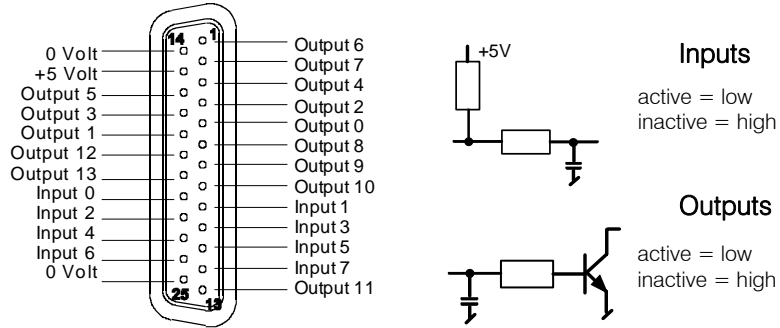

Remote plug
(with 25 pins)

Electrical switching of the inputs
and outputs of the remote socket

4.1.2 Standard allocation of remote lines in Metrohm measuring and titration instruments:

Remote lines	Pin	Function
Input 0	21	Start
Input 1	9	Stop
Input 2	22	Enter
Input 3	10	Clear
Input 4	23	Sample Ready
Input 5	11	not used
Input 6	24	external STOP ^{*)}
Input 7	12	external START ^{*)}
Output 0	5	Ready
Output 1	18	Conditioning ok
Output 2	4	Determination busy
Output 3	17	EOD (End of Determination)
Output 4	3	L1
Output 5	16	Error
Output 6	1	Activate L3
Output 7	2	Pulse for recorder

^{*)} Sample Processors only

Output lines 8...13 are mostly not used as standard.

Remark: Standard pin assignments are only activated in an instrument's single mode (not in sequence functions).

4.1.3 The standard Remote lines

Assignment of the remote socket according to pins:

Pin	I/O line	Function
1	Output 6	L3 activate
2	Output 7	Pulse for recorder
3	Output 4	L1
4	Output 2	Determination busy
5	Output 0	Ready
6	Output 8	not used
7	Output 9	not used
8	Output 10	not used
9	Input 1	Stop
10	Input 3	Clear
11	Input 5	not used
12	Input 7	external START ^{*)}
13	Output 11	not used
14	0 Volt	
15	+5 Volt	
16	Output 5	Error
17	Output 3	EOD (End of Determination)
18	Output 1	Conditioning ok
19	Output 12	not used
20	Output 13	not used
21	Input 0	Start
22	Input 2	Enter
23	Input 4	Sample Ready
24	Input 6	external STOP ^{*)}
25	0 Volt	

^{*)} Sample Processors only

The pin assignment or the allocation of functions of the remote lines may differ slightly from one Metrohm instrument to another. Consult the '**Instructions for use**' of your instrument.

4.1.4 Wiring of the Metrohm Standard Remote cable

Order no. 6.2141.020 (25-pin)

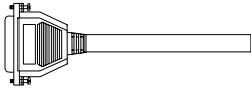

Output 0 (Pin 5)	(Pin 21) Input 0
Output 1 (Pin 18)	(Pin 9) Input 1
Output 2 (Pin 4)	(Pin 22) Input 2
Output 3 (Pin 17)	(Pin 10) Input 3
Output 4 (Pin 3)	(Pin 23) Input 4
Output 5 (Pin 16)	(Pin 11) Input 5
Output 6 (Pin 1)	(Pin 24) Input 6
Output 7 (Pin 2)	(Pin 12) Input 7
Output 8 (Pin 6)	(Pin 6) Output 8
Output 9 (Pin 7)	(Pin 7) Output 9
Output 10 (Pin 8)	(Pin 8) Output 10
Output 11 (Pin 13)	(Pin 13) Output 11
Output 12 (Pin 19)	(Pin 19) Output 12
Output 13 (Pin 20)	(Pin 20) Output 13
Input 0 (Pin 21)	(Pin 5) Output 0
Input 1 (Pin 9)	(Pin 18) Output 1
Input 2 (Pin 22)	(Pin 4) Output 2
Input 3 (Pin 10)	(Pin 17) Output 3
Input 4 (Pin 23)	(Pin 3) Output 4
Input 5 (Pin 11)	(Pin 16) Output 5
Input 6 (Pin 24)	(Pin 1) Output 6
Input 7 (Pin 12)	(Pin 2) Output 7
0 V (Pin 14)	0 V (Pin 14)
0 V (Pin 25)	0 V (Pin 25)



5 Technical specifications

5.1 Keypad

LC-display

2 Lines of 24 characters each
Height 5 mm each

LED-displays

3 LEDs

Plastic foil keypad

key set of 30 keys

5.2 Interfaces

RS 232 plug

connector for computer or printer

Remote socket

programmable parallel interface for controlling external instruments, 14 signal lines (8x input, 14x output), TTL signal level

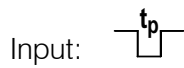
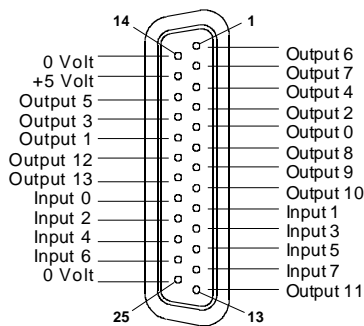

$t_p > 20 \text{ ms}$
50 k Ω appr. pull up

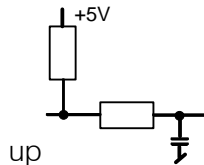

active = low
inactive = high

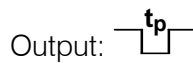

$t_p > 200 \text{ ms}$
 $V_{CEO} = 40 \text{ V}$
 $I_C = 20 \text{ mA}$
Open collector

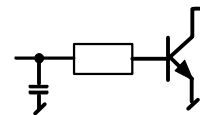

active = low
inactive = high

+5 V: max. load = 20 mA

5.3 MSB Connections

3 MSB connectors

9 pin Mini-DIN sockets
- for 800/700 Dosino or 805 / 685 Dosimat
- for 801 Stirrer or 804 Ti-Stand

5.4 Pumps and pump connectors

Different equipment depending on model:

5.4.1 Built-in pumps and valves

Conveying capacity

> 450 mL/min
manometric lift 2 m

5.4.2 Pump connectors

<i>Outputs</i>	M8 socket: U = 16 ± 1 V I ≤ 0.8 A
----------------	---

for 823 Membrane Pump Unit or 772 Pump Unit

5.5 Swing Head connector

<i>Socket</i>	9 pin Mini-DIN socket - for 786 Swing Head
---------------	---

5.6 Lift

<i>Max. lift path</i>	235 mm
<i>Max. load</i>	30 N appr.
<i>Stroke speed</i>	adjustable, 5...25 mm/s

5.7 Turntable

<i>Turning speed</i>	adjustable, 3...20 angular degrees/s
----------------------	--------------------------------------

5.8 Stirrer connectors

<i>Stirring speed</i>	adjustable to 15 levels 741 Magnetic stirrer 180/min...2600/min 802 / 722 Rod stirrer 180/min...3000/min
-----------------------	--

5.9 Mains connection

<i>Voltage</i>	100... 240 V (±10%)
<i>Frequency</i>	50...60 Hz
<i>Power input</i>	115 W
<i>Fuse</i>	2.0 ATH

5.10 Safety specifications

<i>Construction and testing</i>	according to EN/IEC 61010-1, EN/IEC 61010-2-081, UL 3101-1 protection class I
---------------------------------	--

<i>Safety notice</i>	This instruction manual contains information and warnings which the user should follow to guarantee the safe operation of the instrument.
----------------------	---

5.11 Electromagnetic Compatibility (EMC)

<i>Emitted Interference</i>	Specifications met: - EN/IEC 61326 - EN 55022 / CISPR 22 - EN/IEC 61000-3-2
-----------------------------	--

<i>Interference immunity</i>	Specifications met: - EN/IEC 61326
------------------------------	---------------------------------------

- EN/IEC 61000-4-2
- EN/IEC 61000-4-3
- EN/IEC 61000-4-4
- EN/IEC 61000-4-5
- EN/IEC 61000-4-6
- EN/IEC 61000-4-8
- EN/IEC 61000-4-11
- EN/IEC 61000-4-14
- NAMUR

5.12 Temperatures

Nominal functional range +5...+45 °C
(max. 80 % humidity)

Storage

-20 ...+60 °C
 humidity < +40 °C < 95%
 humidity < +50 °C < 85%
 humidity < +60 °C < 50%

Transport

-20 ...+60 °C
humidity < +40 °C < 95%
 humidity < +50 °C < 85%
 humidity < +60 °C < 50%

5.13 Dimensions and material

Height 730 mm
Width 280 mm
Depth 500 mm (2.778.XXXX models)
 530 mm (2.789.XXXX models)

Materials

- *Sample Processor case* metal case, surface-treated
- *Keypad case* Crastin (PBTB), aluminum-steamed on the inside
- *Keypad foil* Polyester, resistant to chemicals