

OMNIS Sample Robot Pick&Place

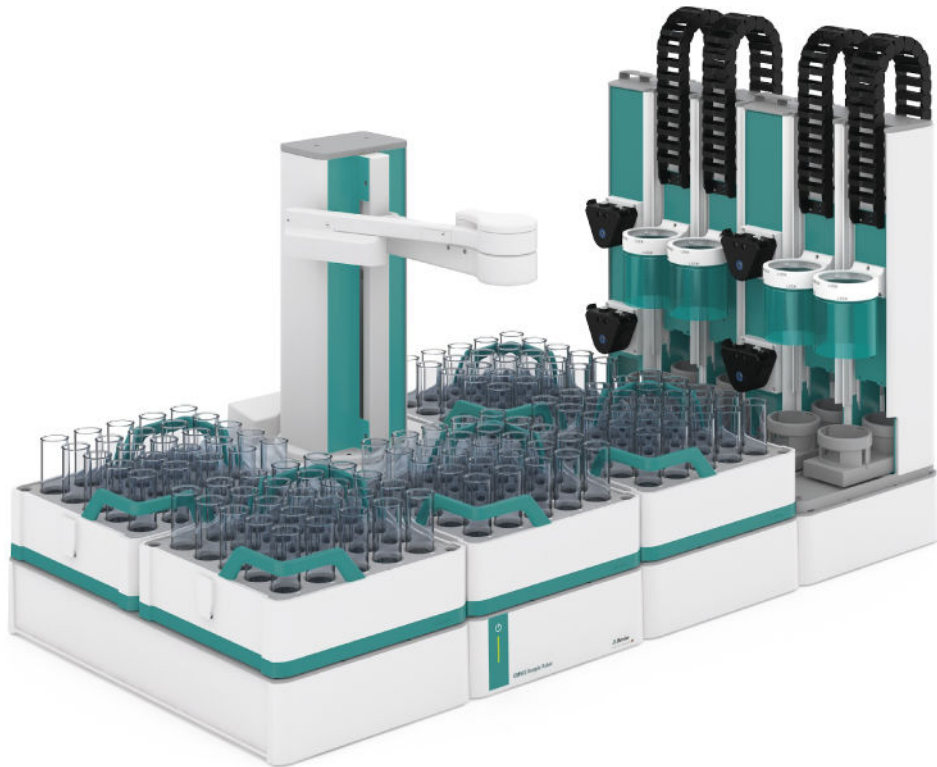

2.101X.1010

Product manual

8.1012.8001EN / 2021-07-23



Metrohm AG
Ionenstrasse
CH-9100 Herisau
Switzerland
+41 71 353 85 85
info@metrohm.com
www.metrohm.com

OMNIS Sample Robot Pick&Place

2.101X.1010

Product manual

8.1012.8001EN /
2021-07-23

Technical Communication
Metrohm AG
CH-9100 Herisau

This documentation is protected by copyright. All rights reserved.

This documentation has been prepared with great care. However, errors can never be entirely ruled out. Please send comments regarding possible errors to the address above.

Disclaimer

Deficiencies arising from circumstances that are not the responsibility of Metrohm, such as improper storage or improper use, etc., are expressly excluded from the warranty. Unauthorized modifications to the product (e.g. conversions or attachments) exclude any liability on the part of the manufacturer for resulting damage and its consequences. Instructions and notes in the Metrohm product documentation must be strictly followed. Otherwise, Metrohm's liability is excluded.

Table of contents

1	Overview	1
1.1	OMNIS Sample Robot Pick&Place – Product description	1
1.2	OMNIS Sample Robot Pick&Place – Product versions	1
1.3	Main module Pick&Place – Product versions	2
1.4	Pick&Place module – Product versions	2
1.5	Peristaltic pump module – Product versions	2
1.6	Symbols and conventions	3
1.7	Further information	3
1.8	Accessories	3
2	Safety	5
2.1	Intended use	5
2.2	Responsibility of the operator	5
2.3	Requirements for operating personnel	6
2.4	Safety instructions	6
2.4.1	Danger from electrical potential	6
2.4.2	Danger from biological and chemical hazardous substances	6
2.4.3	Danger from highly flammable substances	7
2.4.4	Danger from leaking liquids	7
2.4.5	Danger during transport of the product	8
2.4.6	Dangers due to automated motion sequences	8
2.5	Design of warning messages	8
2.6	Meaning of warning signs	9
3	Functional description	11
3.1	OMNIS Sample Robot S Pick&Place – Overview	11
3.2	OMNIS Sample Robot M Pick&Place – Overview	12
3.3	OMNIS Sample Robot L Pick&Place – Overview	13
3.3.1	Main module Pick&Place – Overview	14
3.3.2	Main module Pick&Place – Overview of functions	15
3.3.3	Pick&Place module – Overview	16
3.3.4	Peristaltic pump module – Overview	18
3.3.5	Peristaltic pump – Overview	21
3.3.6	Rack base – Overview	22

8.3	Replacing the beaker adapter	52
8.4	Replacing the titration head	55
8.5	Checking the pump tubing	58
8.6	Replacing the pump tubing	60
8.7	Cleaning the product surface	64
9	Troubleshooting	65
9.1	Opening the gripper manually	65
10	Disposal	67
11	Technical specifications	68
11.1	Ambient conditions	68
11.2	Main module – Energy supply	68
11.3	Pick&Place module – Energy supply	68
11.4	Peristaltic pump module – Energy supply	69
11.5	OMNIS sample rack – Energy supply	69
11.6	OMNIS Sample Robot Pick&Place – Dimensions	69
11.7	Main module Pick&Place – Dimensions	70
11.8	Pick&Place module – Dimensions	71
11.9	Peristaltic pump module – Dimensions	71
11.10	OMNIS sample rack – Dimensions	72
11.11	Rack base / module base – Dimensions	72
11.12	Main module Pick&Place – Housing	73
11.13	Pick&Place module – Housing	73
11.14	Peristaltic pump module – Housing	74
11.15	Module base – Housing	74
11.16	Rack base – Housing	74
11.17	OMNIS sample rack – Housing	75
11.18	Main module – Connectors specifications	75
11.19	Rack base – Connectors specifications	76
11.20	OMNIS sample rack – Connectors specifications	76
11.21	Modules – Connectors specifications	76
11.22	Display specifications	76
11.23	Peristaltic pump module – Liquid Handling specifications	76



11.24 Magnetic stirrer – Specifications	77
11.25 OMNIS Sample Robot Pick&Place – Sample handling specifications	77
11.26 Pick&Place module – Sample handling specifications	78
11.27 OMNIS sample rack – Sample processing specifications	78

1 Overview

1.1 OMNIS Sample Robot Pick&Place – Product description

The OMNIS Sample Robot Pick&Place is a modular system for automated sample changes in titrations. The modular construction makes it possible to configure the system in accordance with the area of application.

1.2 OMNIS Sample Robot Pick&Place – Product versions

The OMNIS Sample Robot can be configured individually. The OMNIS Sample Robot Pick&Place is available in the following versions as framework for the configuration:

Table 1 Product versions

Article number	Designation	Version feature
2.1010.1010	OMNIS Sample Robot S Pick&Place	S version
2.1011.1010	OMNIS Sample Robot M Pick&Place	M version
2.1012.1010	OMNIS Sample Robot L Pick&Place	L version

 Information on function licenses is available on the [Metrohm website](#) or from the regional Metrohm representative.

The article number and serial number for identifying the product can be found on the type plate:

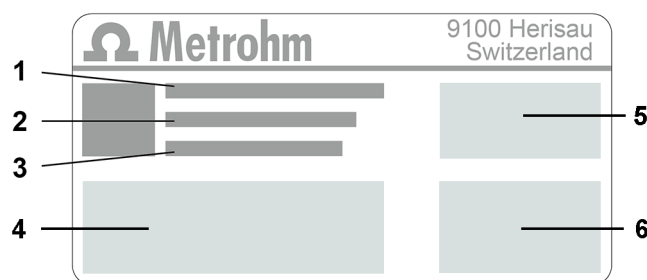

1 (01) = Article number in accordance with GS1 standard

2 (21) = Serial number

3 (240) = Metrohm article number

4 Certification

5 Certification

6 Technical specifications

1.3 Main module Pick&Place – Product versions

The product is available in the following versions:

Table 2 Product versions

Article number	Designation	Version feature
2.1010.0010	Main module Pick&Place S	Main module Pick&Place, S version
2.1011.0010	Main module Pick&Place M	Main module Pick&Place, M version
2.1012.0010	Main module Pick&Place L	Main module Pick&Place, L version

1.4 Pick&Place module – Product versions

The product is available in the following versions:

Table 3 Product versions

Article number	Designation	Version feature
2.1014.0010	Pick&Place module	without magnetic stirrer
2.1014.0110	Pick&Place module	with integrated magnetic stirrer

1.5 Peristaltic pump module – Product versions

The product is available in the following versions:

Table 4 Product versions

Article number	Designation	Version feature
2.1016.0010	Peristaltic pump module (2-channel)	2 installed peristaltic pumps
2.1016.0110	Peristaltic pump module (4-channel)	4 installed peristaltic pumps

1.6 Symbols and conventions

The following formatting may appear in the documentation:

(5-12)	Cross-reference to figure legend The first number refers to the figure number. The second number refers to the product part in the figure.
1	Instruction step Numbers indicate the order of the instructions steps.
Method	Names of parameters, menu items, tabs and dialog windows
File ► New	Menu path
[Continue]	Button or key

1.7 Further information

The Metrohm Knowledge Base <https://guide.metrohm.com> always provides the current version of this document. Further instructions, leaflets, release notes etc. may be available, depending on the product. You can directly access the required information or the associated PDF document using the full-text search function and filters.

1.8 Accessories

Up-to-date information on the scope of delivery and on optional accessories can be found on the Metrohm website. Download this information as follows:

Downloading the accessories list

- 1 Go to <https://www.metrohm.com>.
- 2 Enter the article number of the product (e.g. **2.1001.0010**) into the search field.
The search result is displayed.
- 3 Click on the product.
Detailed information regarding the product is shown on various tabs.



4 On the **Included parts** tab, click the link to download the PDF.
The PDF file with the accessories data is loaded.

 Metrohm recommends downloading the accessories list from the Internet and keeping it for reference purposes.

2 Safety

2.1 Intended use

Metrohm products are used for the analysis and handling of chemicals.

Usage therefore requires the user to have basic knowledge and experience in handling chemicals. Knowledge regarding the application of fire prevention measures prescribed for laboratories is also mandatory.

Adherence to this technical documentation and compliance with the maintenance specifications make up an important part of intended use.

Any utilization in excess of or deviating from the intended use is regarded as misuse.

Specifications regarding the operating values and limit values of individual products are contained in the "Technical specifications" section, if relevant.

Exceeding and/or not observing the mentioned limit values during operation puts people and components at risk. The manufacturer assumes no liability for damage due to non-observance of these limit values.

The EU declaration of conformity loses its validity as soon as modifications are carried out on the products and/or the components.

2.2 Responsibility of the operator

The operator must ensure that basic regulations on occupational safety and accident prevention in chemical laboratories are observed. The operator has the following responsibilities:

- Instruct personnel in the safe handling of the product.
- Train personnel in the use of the product according to the user documentation (e.g. install, operate, clean, eliminate faults).
- Train staff on basic occupational safety and accident prevention regulations.
- Provide personal protective equipment (e.g. protective glasses, gloves).
- Provide suitable tools and equipment to carry out the work safely.

The product may be used only when it is in perfect condition. The following measures are required to ensure the safe operation of the product:

- Check the condition of the product before use.
- Remedy defects and malfunctions immediately.
- Maintain and clean the product regularly.

- Label the product according to regulations if it is used for substances that have a potential for chemical hazards and are generally subject to the Hazardous Substances Ordinance.
- Wear personal protective equipment (e.g. protective glasses, gloves).
- Use exhaust equipment when working with vaporizing hazardous substances.
- Dispose of hazardous substances in accordance with regulations.
- Clean and disinfect contaminated surfaces.
- Only use detergents that do not cause any unwanted side reactions with the materials to be cleaned.
- Dispose of chemically contaminated materials (e.g. cleaning material) in accordance with regulations.
- Proceed as follows in case of a return shipment to Metrohm AG or a regional Metrohm representative:
 - Decontaminate the product or product component.
 - Remove the labeling for hazardous substances.
 - Create a declaration of decontamination and enclose it with the product.

2.4.3 Danger from highly flammable substances

Using highly flammable substances or gases may cause fires or explosions. To avoid danger from highly flammable substances, observe the following:

- Avoid ignition sources.
- Use protective grounding.
- Use exhaust equipment.

2.4.4 Danger from leaking liquids

Leaking liquids may cause injuries and may damage the product. To avoid danger from leaking liquids, observe the following:

- Check the product and its accessories for leakages and loose connections.
- Replace leaking parts and connecting elements without delay.
- Tighten loose connecting elements.
- Do not loosen tubing connections under pressure.
- Do not remove aspiration tubing under pressure.
- Carefully pull the ends of the tubing out of the containers.
- Carefully let liquids from tubing drain into suitable containers.
- Insert the buret tips completely into the containers.
- Remove and dispose of leaked liquids in accordance with regulations.
- If you suspect that liquid has penetrated the instrument, disconnect the instrument from the energy supply. Then have the instrument checked by a regional Metrohm service representative.

WARNING

Type or source of danger

Consequences when not observing the notice: A serious injury that may result in death is probable.

- Measures to avoid the danger

CAUTION

Type or source of danger









Consequences when not observing the notice: A minor to moderate injury is probable.

- Measures to avoid the danger



2.6 Meaning of warning signs

This documentation uses the following warning signs:

Table 5 Warning sign according to ISO 7010

Warning sign	Meaning
	General warning sign
	Warning of electrical voltage
	Warning of hand injuries
	Warning of sharp object
	Warning of hot surface
	Warning of biological hazard
	Warning of toxic materials
	Warning of flammable materials
	Warning of corrosive substances



Warning sign	Meaning
	Warning of optical radiation
	Warning of laser beams

Depending on the intended use of the product, the corresponding warning sign stickers must be placed on the product.

3 Functional description

3.1 OMNIS Sample Robot S Pick&Place – Overview

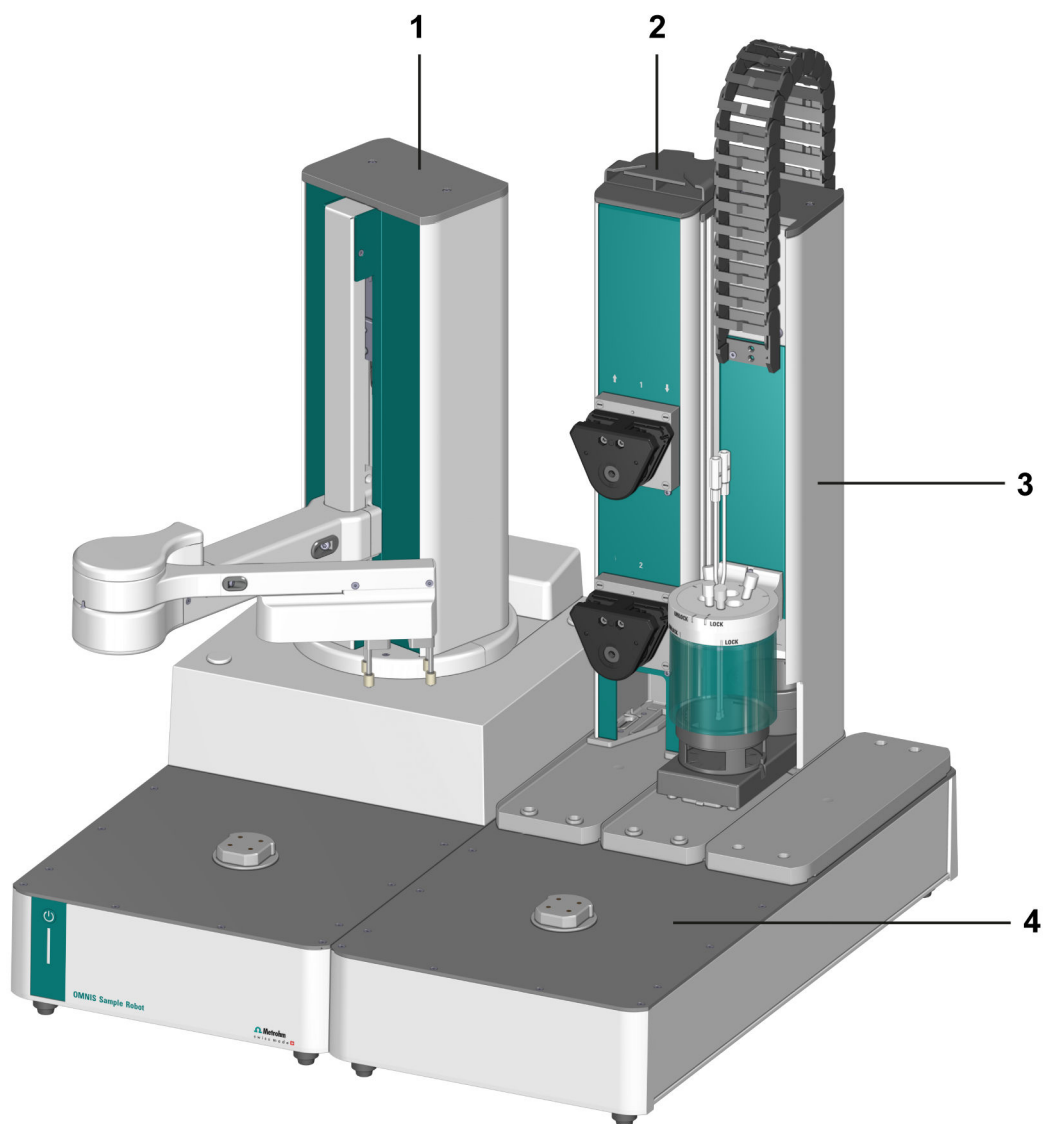

Figure 1 OMNIS Sample Robot S Pick&Place – Overview

1 Main module

2 Pump module

3 Pick&Place module

4 Combined rack module base



3.2 OMNIS Sample Robot M Pick&Place – Overview

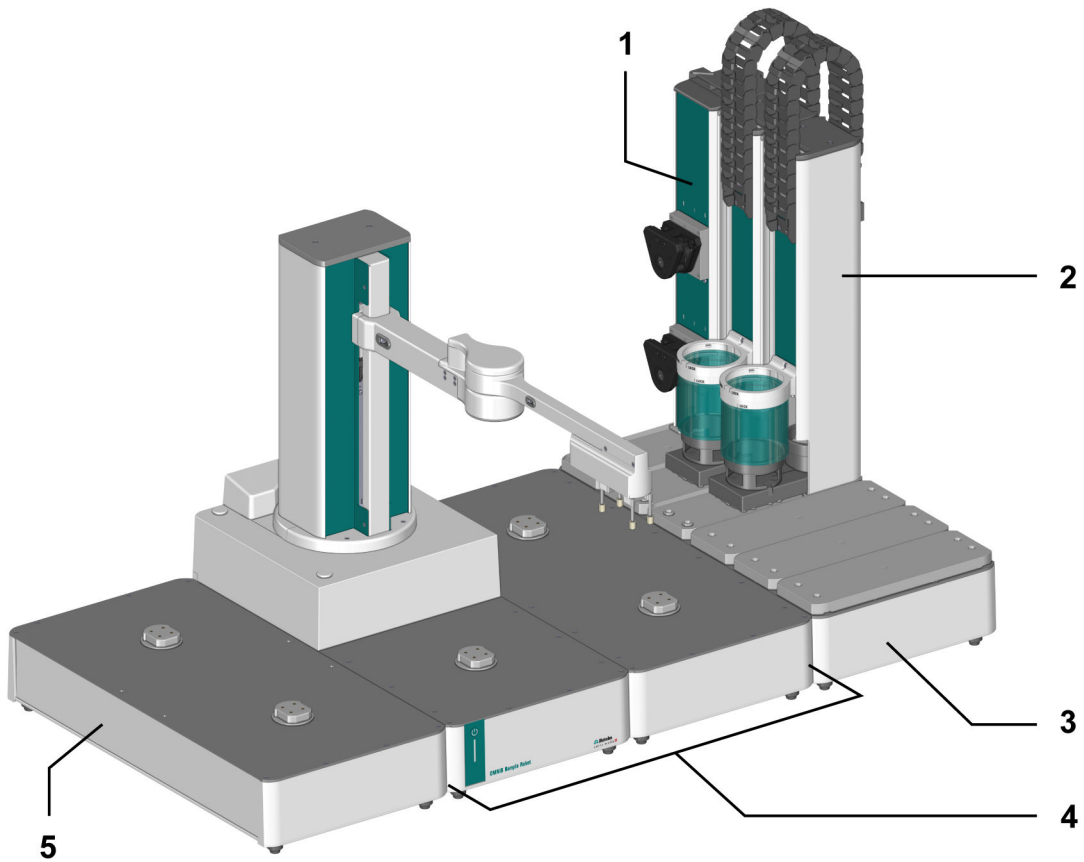

Figure 2 OMNIS Sample Robot M Pick&Place – Overview

1	Pump module	2	Pick&Place module
3	Module base	4	Main module
5	Rack base		



3.3 OMNIS Sample Robot L Pick&Place – Overview

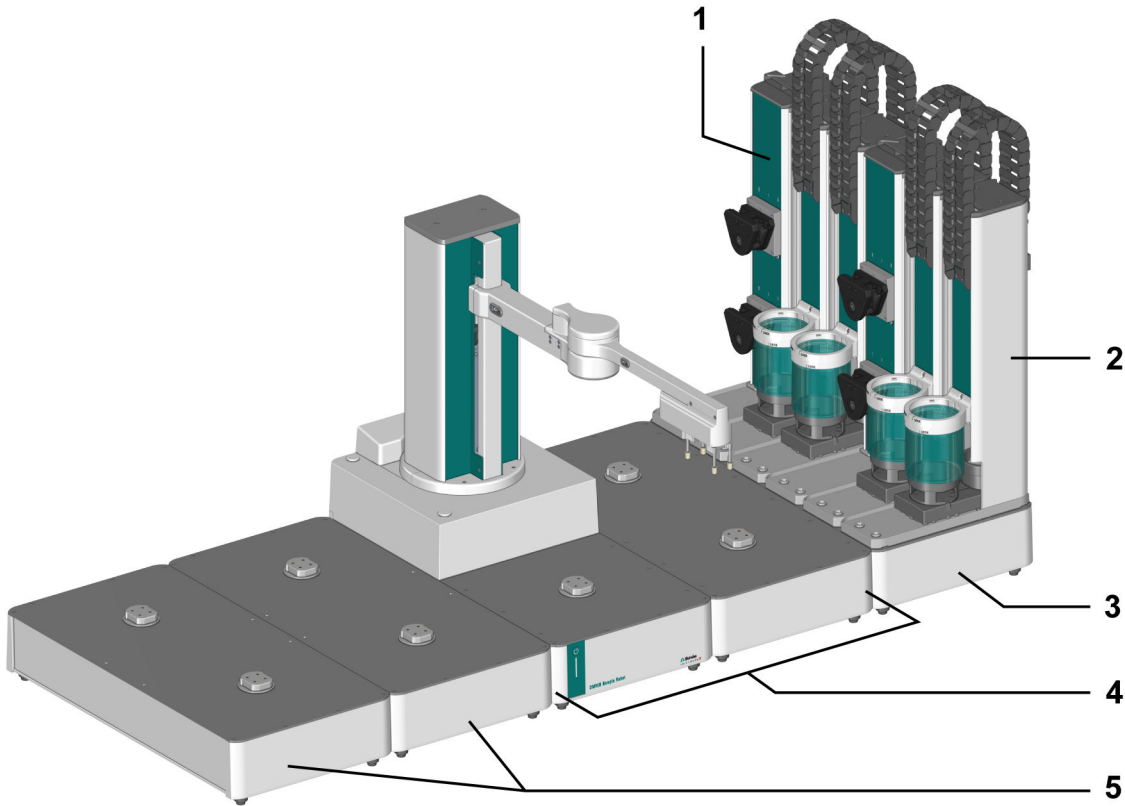

Figure 3 OMNIS Sample Robot L Pick&Place – Overview

1	Pump module	2	Pick&Place module
3	Module base	4	Main module
5	Rack base		



3.3.1 Main module Pick&Place – Overview

Part names

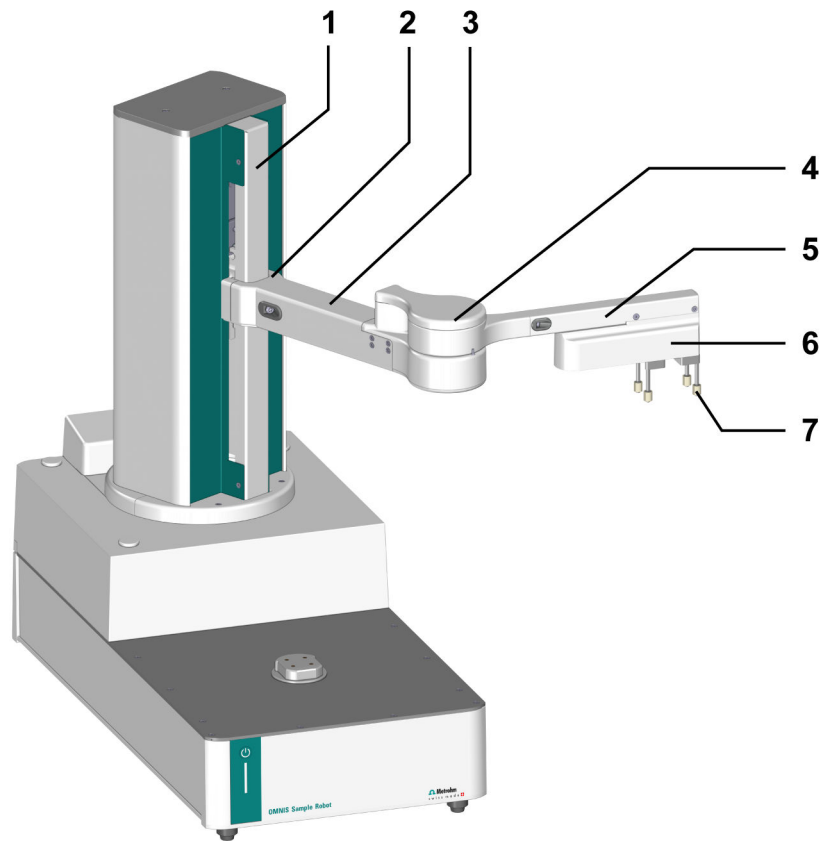

Figure 4 Main module Pick&Place – General overview

1	Main lift	2	Arm holder
3	Lift arm	4	Arm joint
5	Gripper arm	3 - 5 Robot arm	
6	Gripper	7	Gripper fingers only a sketch

The main lift (4-1) is located on the main module Pick&Place.

The robot arm on the main lift is moved with the arm holder (4-2).

The robot arm consists of the lift arm (4-3), the arm joint (4-4) and the gripper arm (4-5).

The gripper fingers (4-7) are mounted on the gripper (4-6).

3.3.2 Main module Pick&Place – Overview of functions

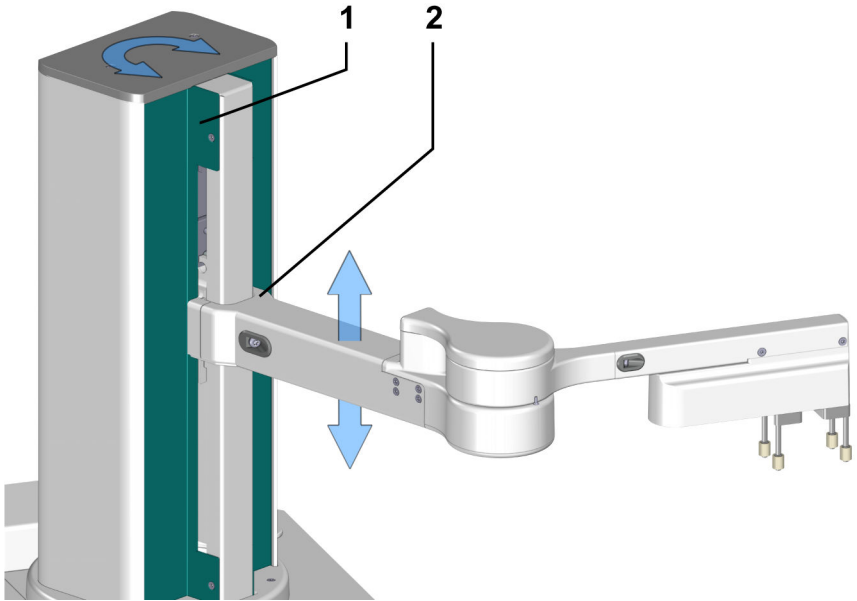

Figure 5 Main lift – Movement capacity

1 Main lift

2 Arm holder

The main lift (5-1) can be rotated to the left and right. The arm holder (5-2) on the main lift moves the robot arm up and down.

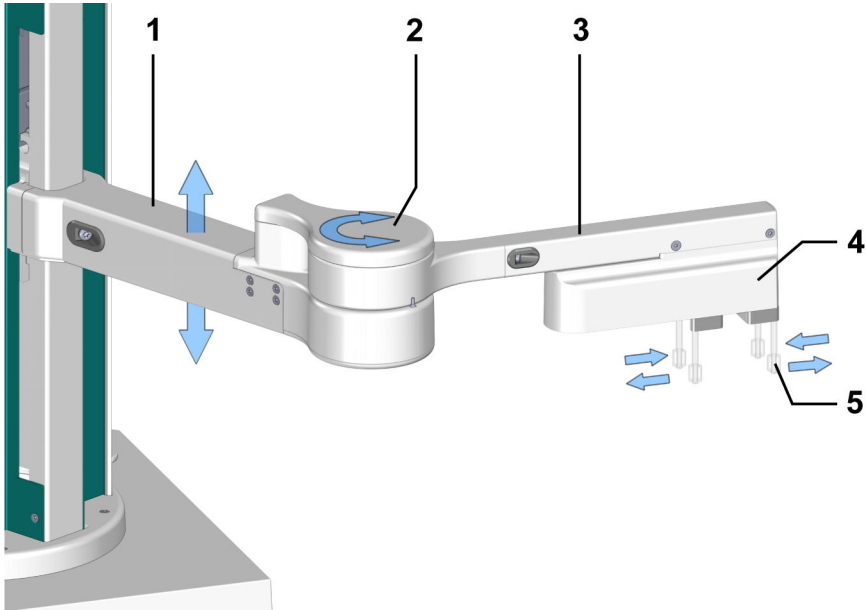

Figure 6 Robot arm – Movement capacity

1 Lift arm

2 Arm joint



3 Gripper arm

4 Gripper

5 Gripper finger

The gripper arm (6-3) can be rotated to the left and right with the arm joint (6-2). The gripper (6-4) can open and close the gripper fingers (6-5) in order to grasp and hold sample vessels.

3.3.3 Pick&Place module – Overview

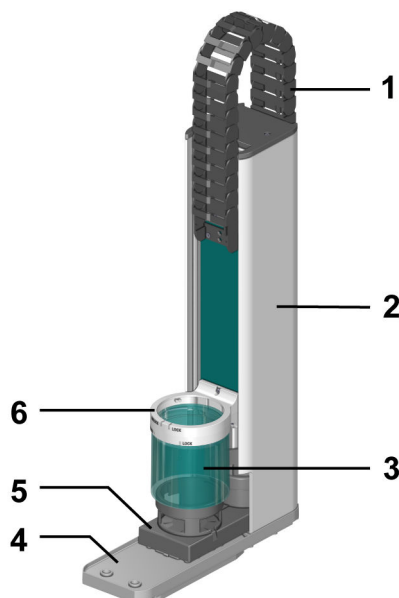

Figure 7 Front – Pick&Place module

1 Guide chain

2 Lift tower

3 Safety shield

4 Collection tray

5 Slide

6 Titration head holder

The slide (7-5) positions the sample beaker under the titration head. The titration head contains sensors, dosing tips, cleaning accessories and occasionally a rod stirrer or homogenizer.

A titration head that fits the sample beaker can be inserted in the titration head holder (7-6). At both slide positions (7-5) (front and rear), the titration head holder (7-6) with the lift tower (7-2) can be moved downwards so that the safety shield (7-3) encases the sample beaker.

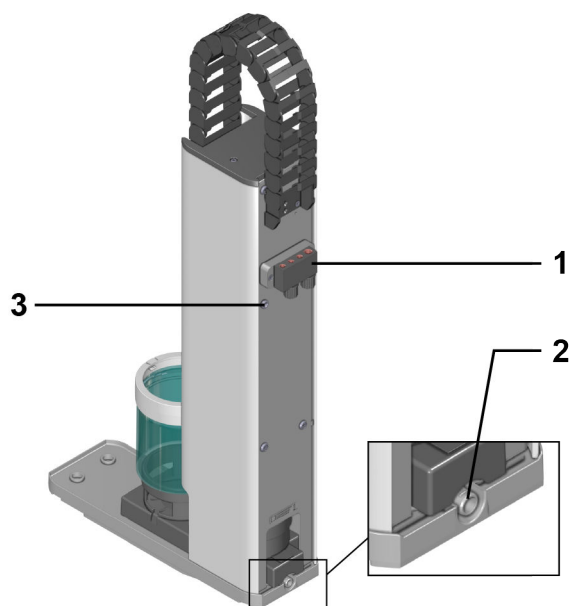

Figure 8 Rear – Pick&Place module

1 Distributor

2 Drain nozzle

3 Grounding socket

Rinsing tubing and aspiration tubing is connected to the distributor (8-1).

A tubing with a tubing adapter is connected to the drain nozzle (8-2). This tubing will route any liquid that escapes via the drain channel into the waste canister. In case of an error, this protects the Pick&Place module from damage.

The grounding socket (8-3) is used to ground the buret tip or a Pt rod that is immersed in solution. The tubing connector (6.1808.030) is necessary for connecting the buret tip.

Option for working with a homogenizer (Polytron PT 1300 D)

A homogenizer (Polytron PT 1300 D) can be inserted in the titration head for homogenization of the sample.



3.3.4 Peristaltic pump module – Overview

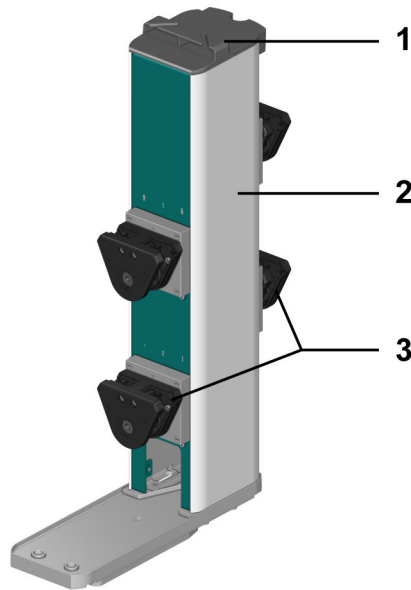

Figure 9 Front – Peristaltic pump module

-
- 1** Tubing organizer
 - 3** Peristaltic pumps

-
- 2** Housing

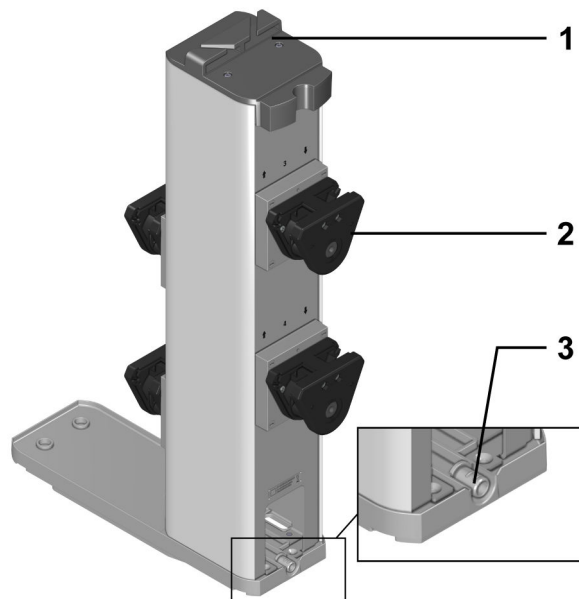

Figure 10 Rear – Peristaltic pump module

-
- 1** Tubing organizer
 - 3** Drain nozzle

-
- 2** Peristaltic pumps

2 or 4 peristaltic pumps (10-2) can be fitted on each peristaltic pump module:

- In the case of the two-way variant, the pumps are mounted on the front only and numbered 1 and 2.
- In the case of the four-way variant, 2 additional pumps are mounted on the rear and numbered 3 and 4.

Arrows indicating inlet and outlet are also to be found above each peristaltic pump next to the numbering. 2 peristaltic pumps each can be used to rinse and clean the sensors in a Pick&Place module.

A tubing organizer (9-1) is located on the top side of the peristaltic pump module to ensure orderly placement and secure fastening of the connected tubing.

A drain nozzle (10-3) to which a tubing is connected via a tubing adapter can be found at the rear of the peristaltic pump module. Any liquid that may escape will be routed through this tubing into the waste canister. In case of an error, this protects the pump module against damage.

Option for working with covered sample beakers

To protect samples from environmental influences for example, the sample beakers can be closed with Dis-Cover lids. Lid trays can be mounted for storing the lids during analysis. Depending on the product version of the sample robot, the lid trays offer space for 2 to 4 lids.

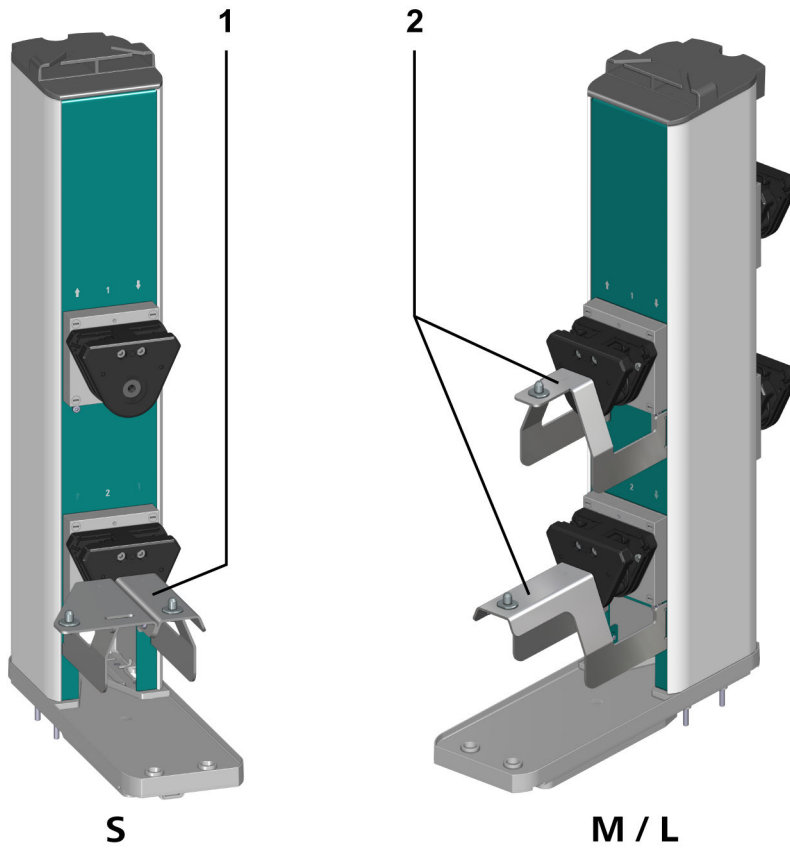

Figure 11 Front – Peristaltic pump module with lid trays

1 Lid tray
For Dis-Cover lid for OMNIS Sample Robot S
Pick&Place

2 Lid tray
For Dis-Cover lid for OMNIS Sample Robot
M/L Pick&Place



3.3.5 Peristaltic pump – Overview

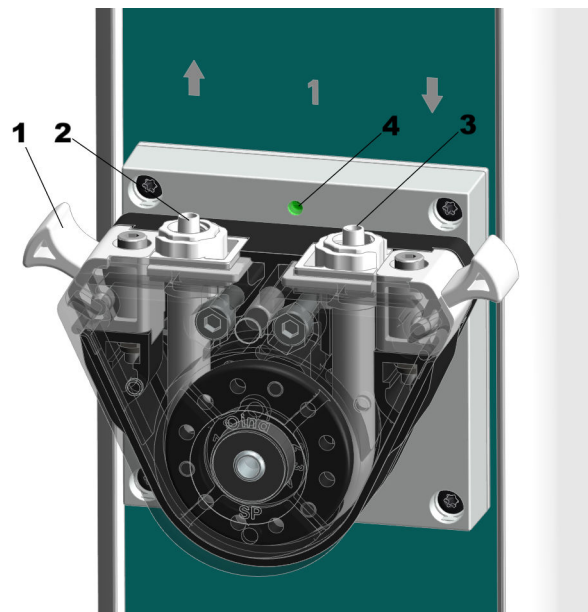

Figure 12 Peristaltic pump – Overview

1 Press clamp

2 Outlet

3 Inlet

4 LED

Supply and drainage tubing is connected at the inlet (12-3) and outlet (12-2) of the peristaltic pump.

A pump tubing is located in the interior of the peristaltic pump between the inlet and the outlet that is pinched off by four rollers. The conveyance medium is pumped through the system by this volume displacement.

The press clamp (12-1) is used to fix the tubing in the peristaltic pump. The press clamp can be dismantled to check the pump tubing and to replace it.

The LED (12-4) displays the status of the peristaltic pump.



3.3.6 Rack base – Overview

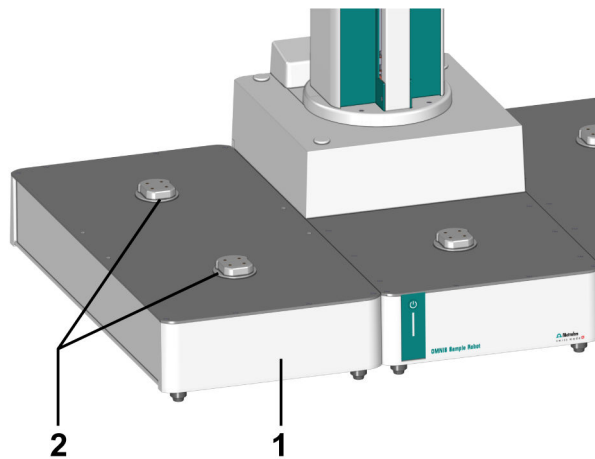

Figure 13 Rack base – Overview

1 Rack base

2 Rack holder

On each rack base (13-1), up to 2 OMNIS sample racks can be placed on the rack holders (13-2).

3.3.6.1 OMNIS sample rack – Overview

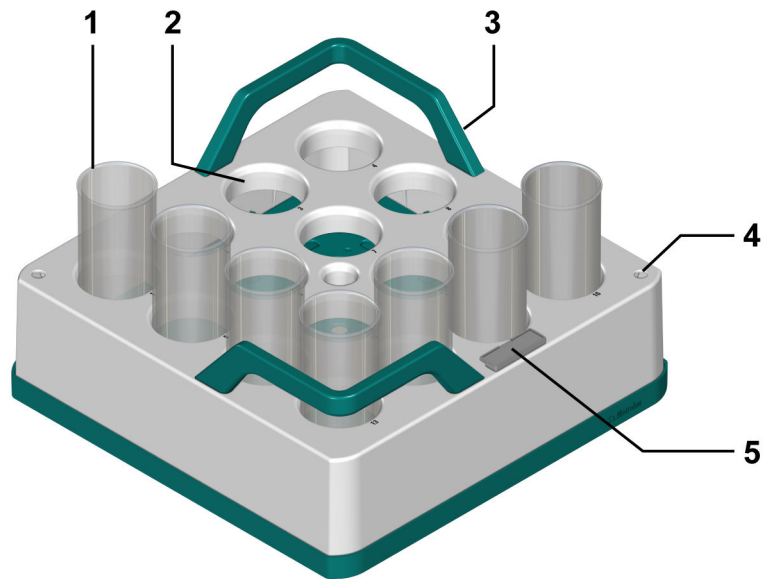

Figure 14 OMNIS sample rack – Overview

1 Sample vessels

2 Sample position

3 Transport handles

4 Spout hole

5 Label holder

The sample vessels (14-1) are placed in sample positions (14-2) in the OMNIS sample rack.

The transport handles (14-3) allow for the OMNIS sample rack to be transported by hand so that it can be set down on or removed from the rack holder of the rack base. Several empty OMNIS sample racks can be stacked on top of one another on the transport handles.

The OMNIS sample rack contains spout holes (14-4) at the top for emptying liquids that seeped through due to overflowing, spilling or cleaning.

 The OMNIS sample rack is not dishwasher-safe.

Table 6 Versions of the OMNIS sample rack

Vessel volume	Number of vessels	Article number
250 mL	9	6.02041.010
200 mL	9	6.02041.020
150 mL	9	6.02041.050
120 mL	16	6.02041.030
75 mL	25	6.02041.040

3.4 OMNIS Sample Robot Pick&Place – Functional description

The OMNIS Sample Robot Pick&Place is a modular system for automated sample changes in titrations. The modular construction makes it possible to configure the system in accordance with the area of application.

The system consists of the following components:

- Main module Pick&Place
- Pick&Place module
- Peristaltic pump module
- Rack base
- Module base

3.4.1 Main module Pick&Place – Functional description

The main module supplies all of the attached modules in the OMNIS sample robot system with electricity. The main lift with the robot arm of the sample robot is located on the main module. The robot arm transports the sample beakers to the workstations and back to the sample rack. The control hardware is integrated in the interior of the main module.

See also

3.4.4 Peristaltic pump – Functional description

The pump tubing in the interior connects the inlet and the outlet of the peristaltic pump. This pump tubing is pinched off by 4 rollers. Media are aspirated in and out by the squeezing of the pump tubing and the volume displacement that results from it.

3.4.5 Rack base – Functional description

The rack base is the skeletal structure for the sample robot. The OMNIS sample racks are placed on the rack holders of the rack base. Sensors in the rack holder let the system know if and what sample rack is present.

If, e.g., a sample rack is removed before the analysis, the system recognizes that the sample rack is missing. This sample rack will no longer be approached and it is displayed as absent in the OMNIS Software.

3.5 OMNIS Sample Robot – Indicators and controls

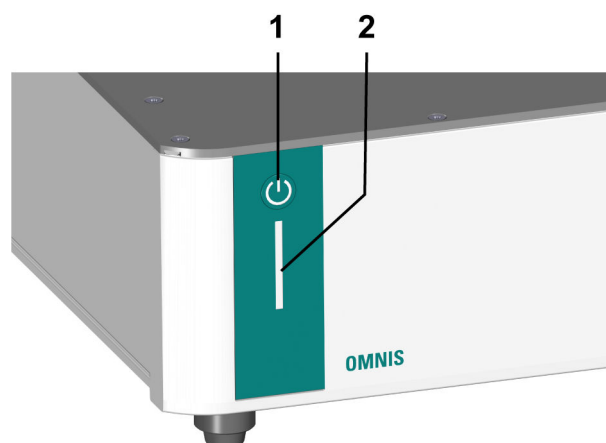

Figure 15 OMNIS Sample Robot – Indicators and controls

1 On/off switch

2 Status display
multi-colored

Indicators

The status of the instrument is displayed with the status display (15-2) using different colors.

Controls

The on/off switch (15-1) is used for the hardware-side operation of the OMNIS Sample Robot.

Table 7 Behavior of the on/off switch

Pressure duration	Acoustic signal	Function on the OMNIS Sample Robot
short pressing (1 s)	beep after status display reaction	switching on the instrument
short pressing (2 s)	beep after 2 s	shutting down the instrument
long pressing (approx. 5 s)	dual beep	gripper opens (if available)







See also

[Switching the OMNIS Sample Robot on and off \(chapter 7.2, page 44\)](#)

[System – Signals \(chapter 3.6, page 26\)](#)

3.6 System – Signals

System components with status indicators show their operating status with colors and/or flashing patterns. The meaning of the colors and flashing patterns is explained in the following table.

Visual signal		Meaning
	LED lights up yellow.	System start or initialization
	LED flashes yellow (slowly).	Ready for connection setup or locking
	LED flashes yellow (fast).	Connection setup started or locking underway
	LED lights up green.	Ready for operation
	LED flashes green (slowly).	In operation
	LED flashes red (fast).	Malfunction or error

Some system components only use part of the explained flashing patterns.

3.7 Main module – Connectors

Symbol labeling

Observe the connector symbols when connecting the instruments.

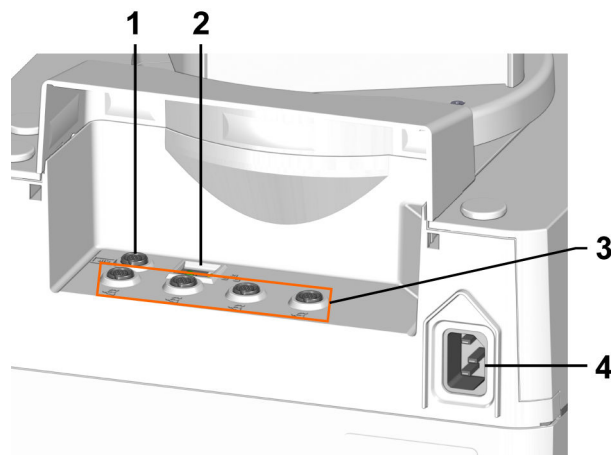

Figure 16 Main module – Connectors

1 Human Interactive Device (HID)



2 Local Area Network (LAN)



for integrating the OMNIS sample robot in the company Ethernet

3 Metrohm Device Link (MDL)



4 MDL connectors for additional modules

4 Power socket



4 Delivery and packaging

4.1 Delivery

Inspect the delivery immediately upon receipt:

- Check the delivery against the delivery note to ensure completeness.
- Check the product for damage.
- If the delivery is incomplete or damaged, contact your regional Metrohm representative.

4.2 Packaging

The product and accessories are supplied in protective special packaging. Keep this packaging to ensure safe transportation of the product. If a transport locking device is present, keep this as well for future reuse.

5 Installation

5.1 Installation by Metrohm

As a basic rule, the installation of the system is carried out by the regional Metrohm service representative.

5.2 Setup location

The product is only suitable for operation indoors and may not be used in explosive environments.

The following requirements apply to the setup location:

- The room is well ventilated, protected against direct sunlight and excessive temperature fluctuations.
- The setup space is stable and free of vibrations. The setup space must be suitable for the dimensions and weight of the components (see Technical specifications).
- All cables and connectors are accessible during operation. The cables are safely installed (no tripping hazards).
- The workplace is ergonomically designed and ensures trouble-free operation of the product.

5.3 Lifting the OMNIS Sample Robot

Try to avoid lifting the sample robot after initial installation. This applies especially to the larger models "M" and "L". However, if a transport is necessary, observe the following:

- Lift the sample robot on all 4 sides or transport it on a plate to avoid a sag.
- Check the positioning accuracy of the sample robot after placing the sample robot down.
- If inaccuracies occur, contact the regional Metrohm service representative for a readjustment.



5.4 Replacing the lid seal

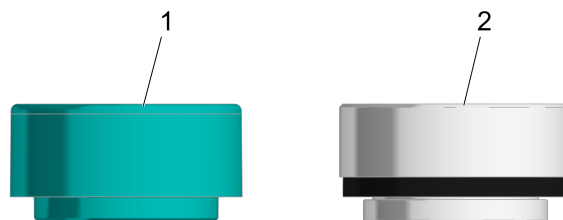

Figure 17 Sample beaker lids

1 Dis-Cover lid

2 KF Dis-Cover lid
With lid seal

The standard lid seals were designed for aqueous applications and Karl Fischer titrations. If more aggressive solvents such as chlorobenzene or glacial acetic acid are used, Metrohm recommends using the sample beaker lids (Dis-Cover lids) without lid seals.

Table 8 Available sample beaker lids

Article number	Designation	Beaker size
6.02710.000	KF Dis-Cover lids for 75 mL sample beakers (P&P) with lid seals	75 mL
6.02710.010	KF Dis-Cover lids for 120 mL sample beakers (P&P) with lid seals	120 mL
6.02710.030	Dis-Cover lids for 75 mL sample beakers (P&P)	75 mL
6.02710.040	Dis-Cover lids for 120 mL sample beakers (P&P)	120 mL
6.02710.050	Dis-Cover lids for 250 mL sample beakers (P&P)	250 mL

-  Always use KF Dis-Cover lids with the corresponding lid seals.
- Replace the lid seal approx. every 6 months.

Installing the lid seal

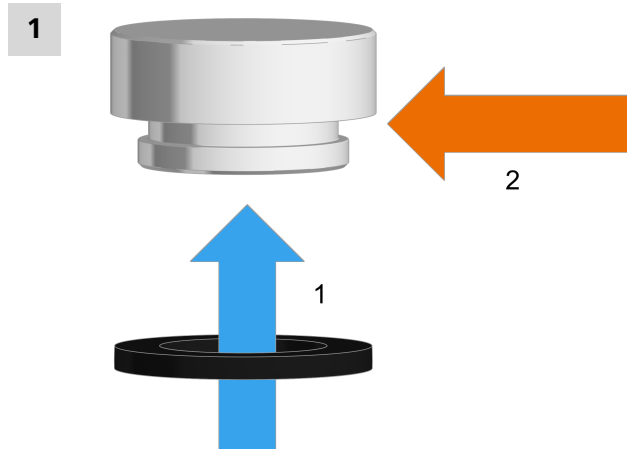

- Check the lid seal for damage. Only use intact lid seals.
- Push the lid seal from below onto the lid bottom (1).
- Check if the lid seal rests flush in the groove all around (2). If necessary, stretch the lid seal and press it flat into the groove.

Removing the lid seal

- 1 ▪ Pull the lid seal down over the lid bottom and remove it.

5.5 Mounting the safety shield

WARNING

Risk of injury due to lack of safety shield

Risk of injury when working without mounted safety shields.

- Never operate instruments without safety shields.
- Before beginning work, make sure that all the safety shields are mounted correctly and are operational.

 The safety shield has the designations "LOCK" for closed and "UNLOCK" for open.

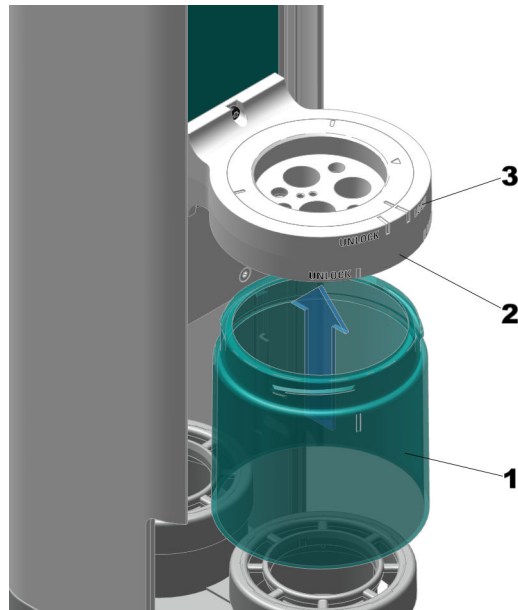

Figure 18 Inserting the safety shield

1 Safety shield

2 Titration head holder

3 Markings "LOCK" and "UNLOCK"

Mounting the safety shield

Prerequisites:

- The sample robot is switched off

1 Inserting the safety shield

Insert the safety shield (18-1) from the bottom into the titration head holder (18-2).

2 Fastening the safety shield

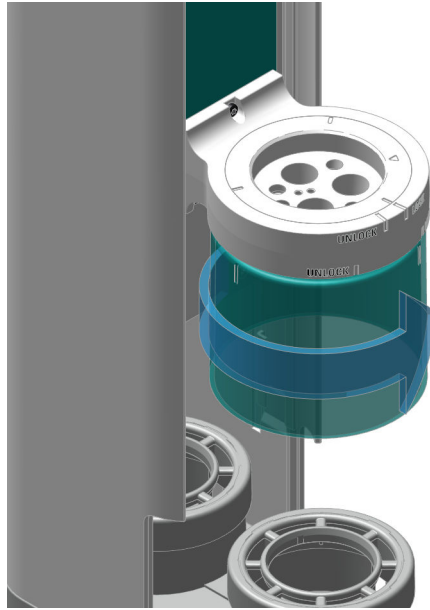

Figure 19 Fastening the safety shield

Rotate the safety shield clockwise until the marking points to "LOCK".

5.6 Connecting the tubing to the distributor of the Pick&Place module

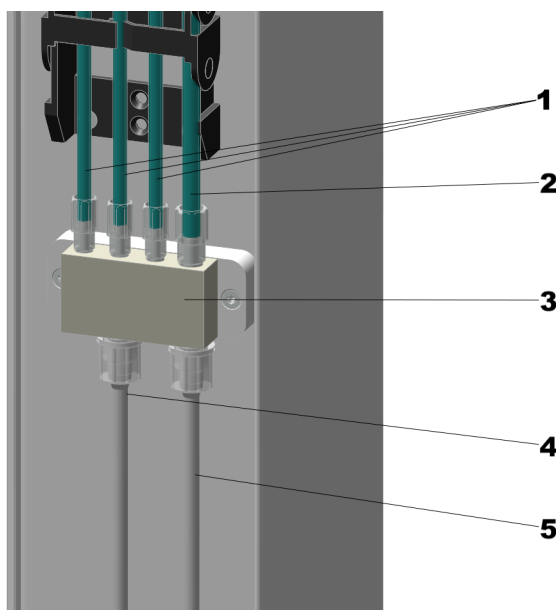

Figure 20 Connecting the tubing to the distributor

1	Rinsing tubing	2	Aspiration tubing
3	Distributor	4	Rinsing tubing
5	Outlet tubing		

Connecting the tubing to the distributor

Prerequisites:

- The sample robot is switched off

1 Connecting the rinsing tubing

Manually tighten or plug in the three rinsing tubings (20-1) in the M3 bore holes of the distributor (20-3).

i The rinsing tubings lead to the spray nozzles of a titration head in the Pick&Place module.

2 Connecting the aspiration tubing

Manually tighten the aspiration tubing (20-2) in the M3 bore hole of the distributor.

3 Connecting the rinsing tubing

Remove the union nut.

Pull the end of the tubing over the connection nipple of the distributor and fasten in place with the union nut.

i The rinsing tubing (20-4) leads to the rinsing pump (**Pump 1** or **Pump 3**) and can be cut to the correct length.

4 Connecting the outlet tubing

Remove the union nut.

Pull the end of the tubing over the connection nipple of the distributor and fasten in place with the union nut.

i The outlet tubing (20-5) leads to the aspiration pump (**Pump 2** or **Pump 4**) and can be cut to the correct length.

5.7 Sticking on magnets (retrofitting the OMNIS Sample Robot S)

Magnets are stuck on the main module Pick&Place for retrofitting the OMNIS Sample Robot S with a drain channel. The magnets help to bring the drain channel in the correct position when attaching.

Retrofitting is not necessary for the OMNIS Sample Robot M / L: The magnets are already attached to the drain channel ex works for the OMNIS Sample Robot M / L and they remain in place, as the side panel of the module base is made of metal and the magnets can stick to it.

1

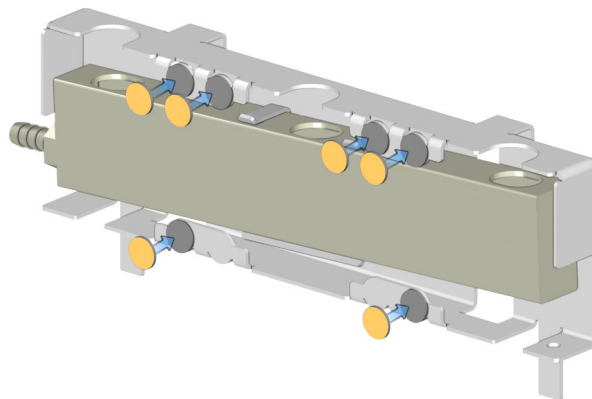



- Check if there are magnets present on the main module Pick&Place. If necessary, stick on magnets:
 - Position the supplied magnets on the round surfaces of the drain channel (see figure).
 - Remove the backing of the stickers and move the drain channel close to the main module Pick&Place.
 - Insert the tubings of the drain nozzles in the intended openings. (see "*Mounting the drain channel*", chapter 5.8, page 36)
 - Move the drain channel even closer to the main module Pick&Place, so that the magnets stick in the correct position.

5.8 Mounting the drain channel

Depending on the version of the OMNIS Sample Robot, the drain channel is located in different positions:

- For the OMNIS Sample Robot S, the drain channel is installed in the back, below the workstations.
- For the OMNIS Sample Robot M and L, the drain channel is installed on the right side, below the workstations.

Required accessories:

- 2 tubings (6.01803.000) for connecting to the tubing adapter and the waste canister
- Tubing adapters (6.01804.500), 1 tubing adapter per Pick&Place module or pump module
- Drain channel for OMNIS Sample Robot S (6.01804.410)
or

- Drain channel for OMNIS Sample Robot M or L (6.01804.430)

1 Cutting to length and fastening the tubing

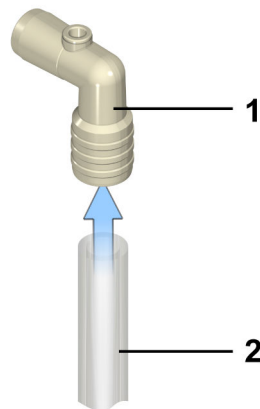

- Cut 1 piece of tubing with a length of approx. 3 to 5 cm off the tubing (6.01803.000) for each Pick&Place module or pump module.
- Attach the piece of tubing (2) to the tubing adapter (1) (6.01804.500).

2 Mounting the tubing adapter

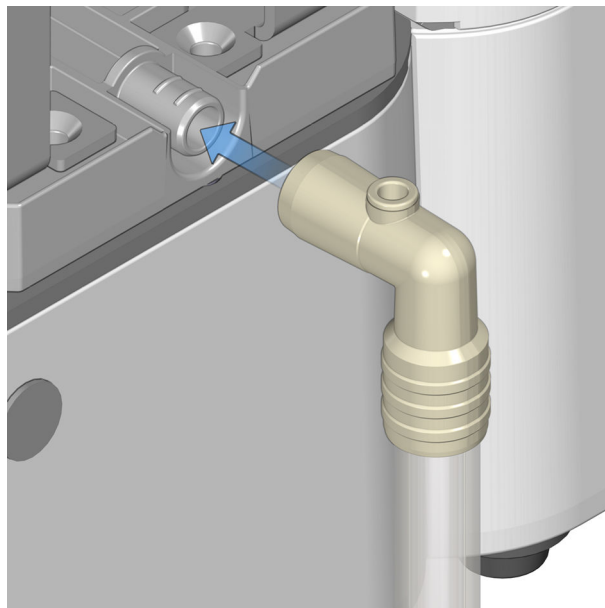

- Push the tubing adapter (6.01804.500) onto the drain nozzle.



3 Positioning the drainage conduit

i The drainage conduit (inside the drain channel) can be installed in 2 different directions to adjust the orientation of the drain to the local installation.

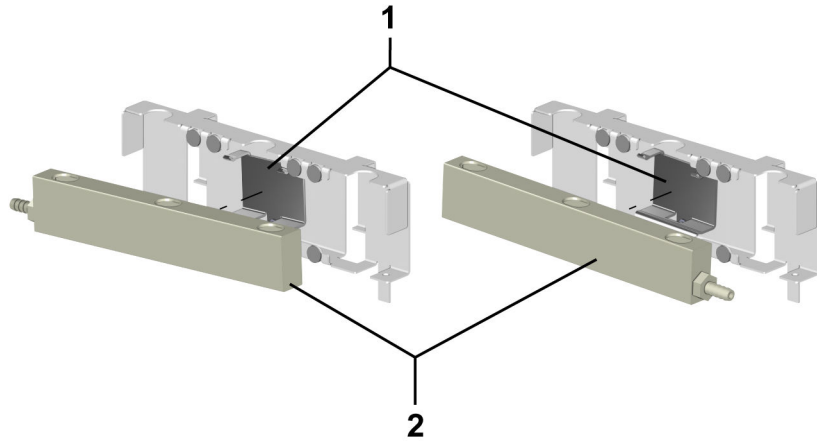

- Check if the drainage conduit (2) is correctly oriented. If necessary, install the drainage conduit the other way round:
 - Remove the drainage conduit from the holding clip (1).
 - Install the drainage conduit rotated by 180° in the holding clip.

4 Attaching the drain channel

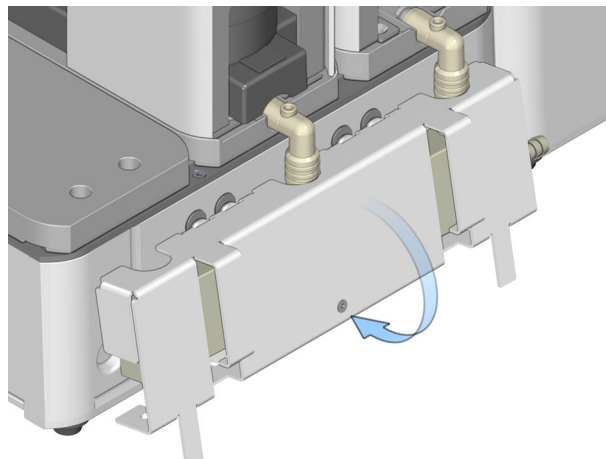

i When retrofitting the OMNIS Sample Robot S, magnets must first be stuck on the main module Pick&Place. (see ["Sticking on magnets \(retrofitting the OMNIS Sample Robot S\)", chapter 5.7, page 35](#))

- Move the drain channel close to the main module Pick&Place.
- Insert the tubings of the drain nozzles in the intended openings.



- Move the drain channel even closer to the main module Pick&Place, so that the drain channel is positioned and fixed by the magnets.

5 Connecting the drain channel with the waste canister

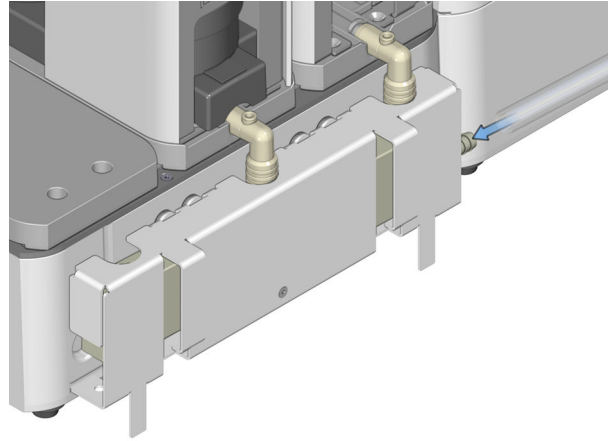

- Cut another tubing (6.01803.000) to length. The tubing should be long enough to connect the drain channel with the waste canister.
- Push one end of the tubing (6.01803.000) onto the tubing olive of the drain channel.
- Insert the other end of the tubing (6.01803.000) in the waste canister.
Make sure that the tubing is installed with an inclination towards the waste canister.

6 Organizing tubings and cables

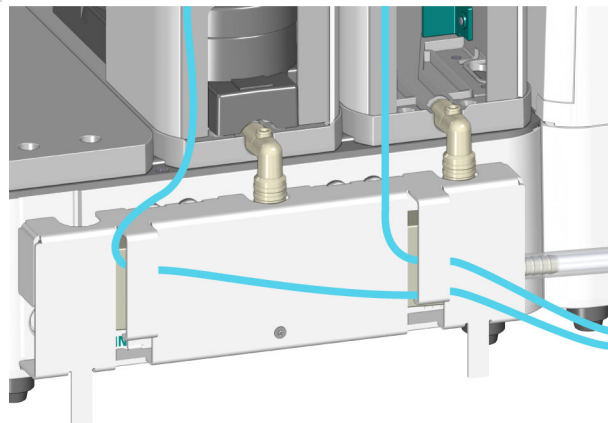

- Secure the tubings and cables of the workstations in the holding clips of the drain channel.

5.9 Connecting the inlet and outlet tubing

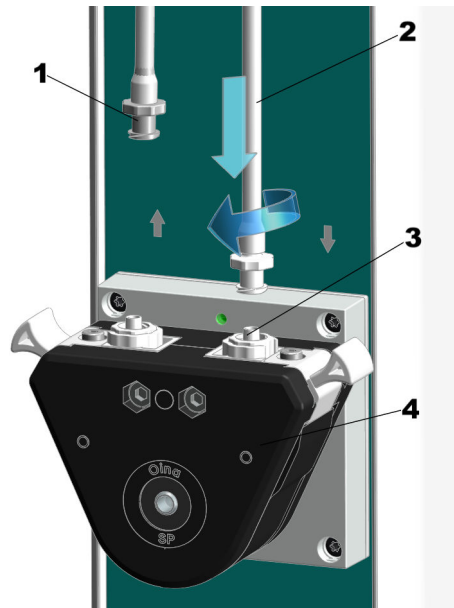

Figure 21 Connecting the inlet and outlet tubing

1 Outlet tubing

2 Inlet tubing

3 Connecting element

4 Peristaltic pump

Connecting the inlet and outlet tubing of the peristaltic pump

Prerequisites:

- The sample robot is switched off

1 Plug the inlet tubing (21-2) into the connecting element (21-3) of the peristaltic pump (21-4) by hand and rotate clockwise until it fits closely.

i The tubing connections at the inlet and outlet of the peristaltic pump correspond to the "Luer lock system".
The peristaltic pump rotates clockwise.

2 Connect the outlet tubing (21-1) following the same procedure.

3 Place the tubing without squeezing it onto the top side by using the tubing organizer. Make sure that the tubing is positioned as close as possible to the housing.

The pump operates the aspiration tubing and the three rinsing tubings

5.10 Plugging in the power cord

WARNING

Electrical potential

Contact with electrical potential can cause serious injuries or death.

- Operate the product only if it is in perfect condition. The housing must also be intact.
- Only use the product with the covers fitted.
- Protect live components (e.g. power supply unit, power cord, connection sockets) against moisture.
- Always have maintenance work and repairs on electrical components carried out by a regional Metrohm service representative.

Required accessories:

- Power cord:
 - Length: max. 2 m
 - Number of conductors: 3, with protective ground
 - Conductor cross-section: 3x min. 1.0 mm² / 18 AWG
- Instrument plug:
 - IEC 60320, type C13, 10 A
- Power plug:
 - 6.2122.XX0 (according to customer requirement), min. 10 A

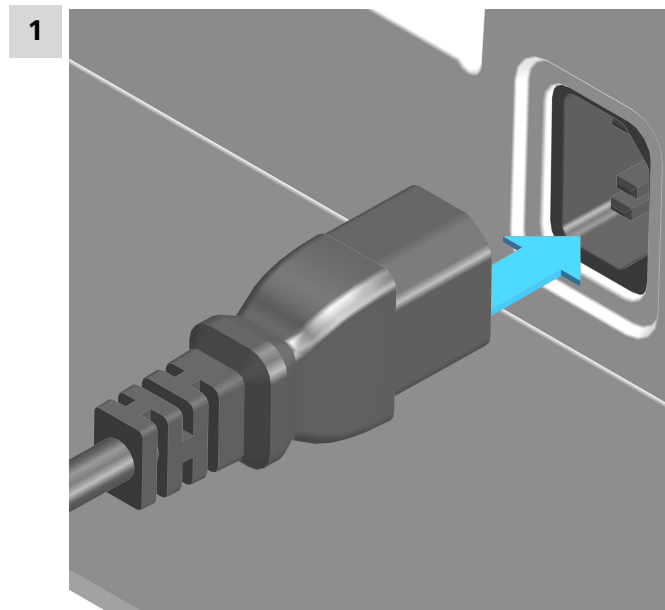

- Plug the power cord into the product's power socket. Only use permitted power cords.



- Connect the power cord to the energy supply.
- To power down the product, unplug the power cord from the energy supply.



6 Start-up

6.1 Initial start-up by Metrohm

As a basic rule, the initial start-up of the system is carried out by the regional Metrohm service representative.

7.3 Attaching and removing the OMNIS sample rack

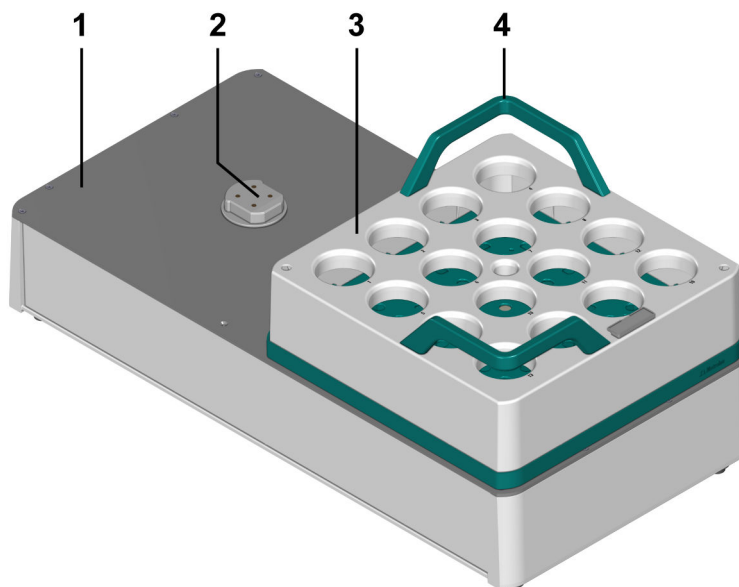

Figure 22 Overview – Rack base and OMNIS sample rack

- | | | | |
|----------|--------------------------|----------|--------------------------|
| 1 | Rack base | 2 | Rack holder |
| 3 | OMNIS sample rack | 4 | Transport handles |

CAUTION

Using non-authorized sample vessels

The sample robot was designed for use with specific sample vessels. Error-free and safe operation can therefore only be ensured with authorized sample vessels. The use of non-authorized sample vessels can lead to injuries and/or damage of the sample robot.

- Use only sample vessels that are authorized by Metrohm.



Attaching an OMNIS sample rack

1

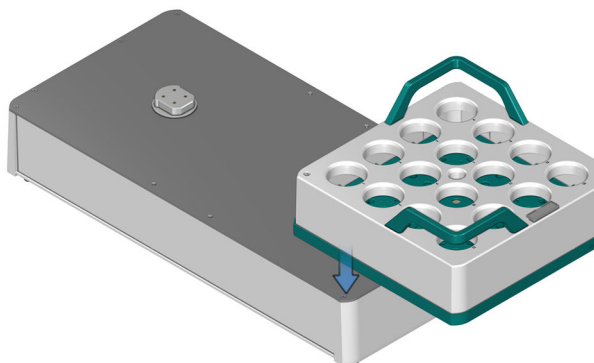

Grip the OMNIS sample rack (22-3) on the transport handles (22-4) with both hands and set it down on the rack base (22-1).

Because of the shape of the rack holder and the counterpart on the OMNIS sample rack, the OMNIS sample rack can only be placed on the rack base in one position.

2

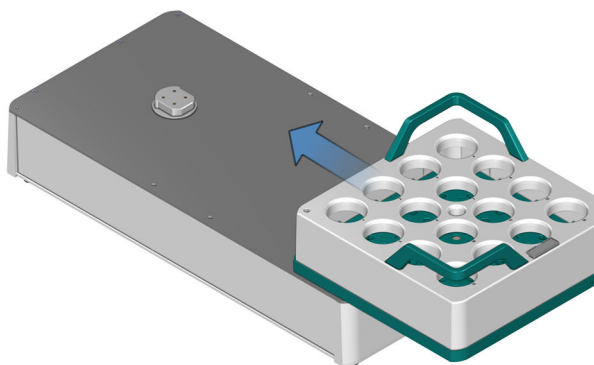

Push the OMNIS sample rack towards the front until it is firmly seated on the rack holder (22-2).

A brief signal will sound as soon as the OMNIS sample rack is seated correctly on the rack holder.

Removing the OMNIS sample rack

- 1 Grip the OMNIS sample rack (22-3) on the transport handles (22-4) with both hands and remove it towards the top.

A brief signal will sound as soon as the OMNIS sample rack has been removed.

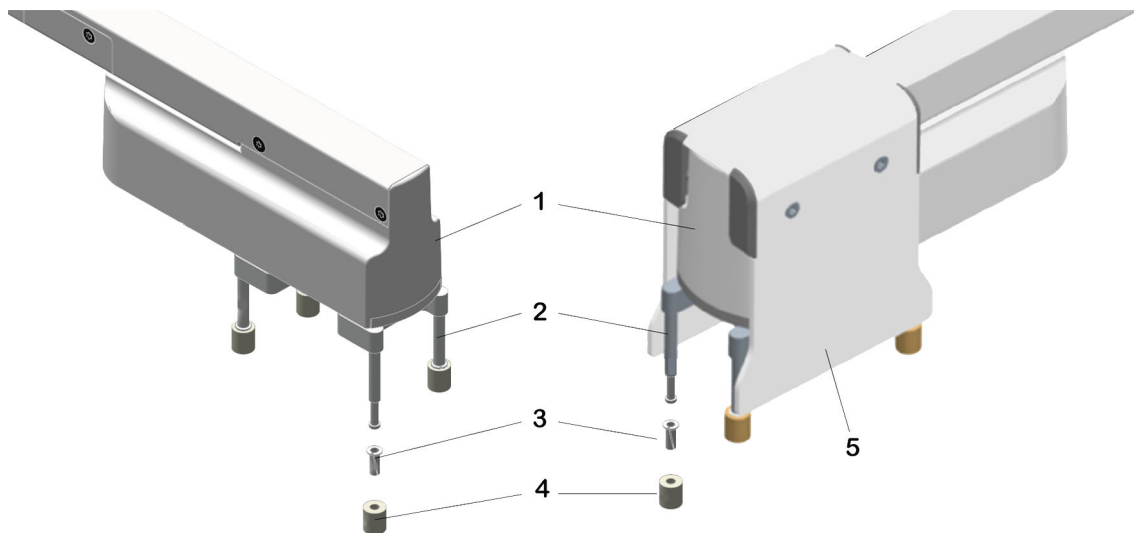

Figure 23 Replacing finger tips and sleeves

1 Gripper

2 Gripper fingers

for 43 - 65 mm (6.02601.010), for 50 - 72 mm (6.02601.020), for 28 - 48 mm (6.02601.040)

3 Sleeves

4 Finger tip

Consumable Kit OMNIS Gripper (6.05700.000)

5 Retainer

Dismantling finger tips and sleeves

Prerequisites

- The sample robot is switched off.
- There is no beaker in the gripper.

i If you are using a gripper with retainer (23-5), lift the retainer off the gripper beforehand.

1 Clasp the gripper (23-1) from above with one hand and hold it firmly.

2 Use the other hand to pull the finger tip (23-4) downwards and off the gripper finger (23-2) by applying gentle rotating movements.

3 Stretch the sleeve (23-3) and pull it off downwards.

i A slot to facilitate assembly and disassembly is located in the sleeve. The sleeve can be stretched over this slot, e.g., with a small screwdriver or fingernail, and then subsequently removed via the lower section on the gripper finger.



Assembling finger tips and sleeves

Prerequisites

- The sample robot is switched off.
- The sleeve and the finger tip are disassembled.

1 Clasp the gripper from above with one hand and hold it firmly.

2 Stretch the sleeve and slide it onto the gripper finger from below.

i A slot to facilitate assembly and disassembly is located in the sleeve. The sleeve can be stretched over this slot, e.g., with a small screwdriver or fingernail, and then subsequently pushed over the lower section on the gripper finger.

3 Using gentle rotating movements, slide the finger tip onto the sleeve from below.

4 Make sure that the finger tip is firmly seated on the gripper finger and that it can still be rotated.

5 Place the retainer, if applicable, back onto the gripper with retainer.

! The gripper with retainer must always be operated with the retainer!

This ensures that the beakers are always gripped correctly.

Replacing finger tips

For gripper fingers for sample beakers with outer diameter 48 - 64 mm, only the finger tips must be replaced.

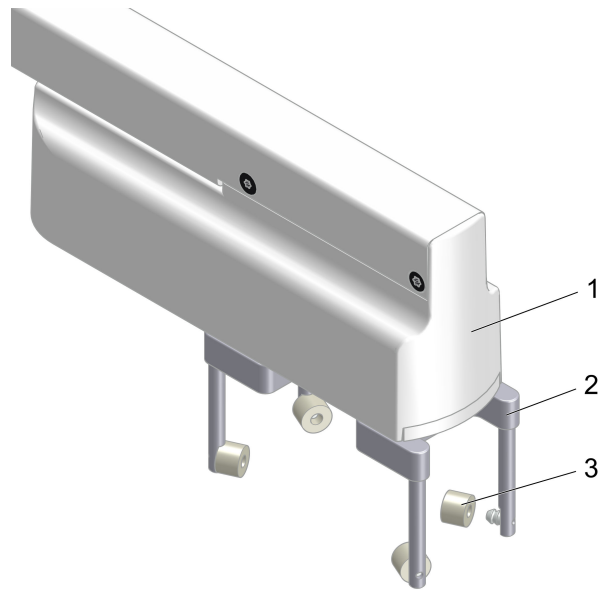

Figure 24 Replacing finger tips

1 Gripper

2 Gripper fingers

for 48 - 64 mm (6.02601.030)

3 Finger tip

(6.05700.250)

Dismantling finger tips

Prerequisites

- The sample robot is switched off.
- There is no beaker in the gripper.

- 1** Clasp the gripper (24-1) from above with one hand and hold it firmly.
- 2** Use the other hand to pull the finger tip (24-3) horizontally and off the gripper finger (24-2) by applying gentle rotating movements.

Assembling finger tips

Prerequisites

- The sample robot is switched off.
- The finger tips are disassembled.

- 1** Clasp the gripper from above with one hand and hold it firmly.
- 2** Using gentle rotating movements, slide the finger tip horizontally onto the gripper finger.



- 3 Make sure that the finger tip is firmly seated on the gripper finger.

8.3 Replacing the beaker adapter

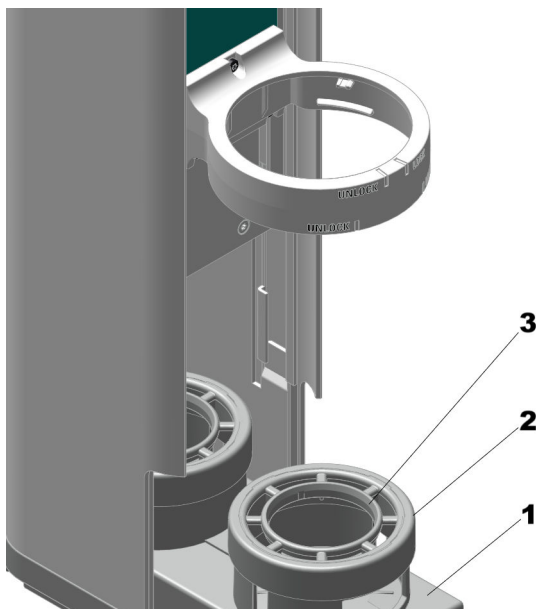

Figure 25 Replacing the beaker adapter

1 Slide

2 Ring

3 Beaker adapter

Table 9 Available beaker adapters and settings

Beaker volume	Beaker diameter	Beaker height	Article number
75 mL	35.5 mm	113 mm	6.01404.040
120 mL	47.3 mm	113 mm	6.01404.030
150 mL	62 mm	96 mm	6.01404.050
200 mL	70 mm	100 mm	6.01404.020
250 mL	64.7 mm	113 mm	no adapter required

Replacing the beaker adapter

Prerequisites:

- The sample robot is switched off

- The slide is extended

1 Removing the ring

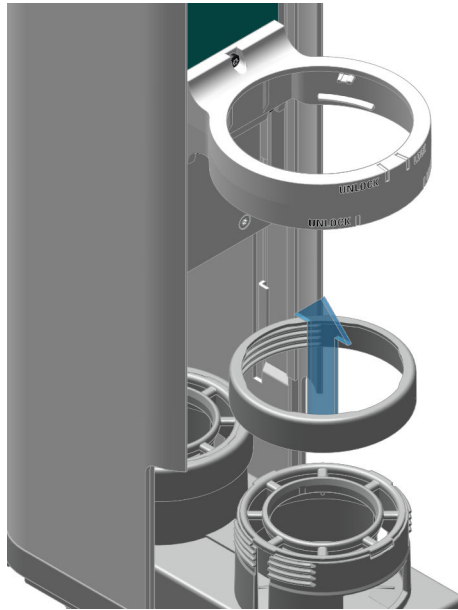

Figure 26 Removing the ring

Rotate the ring (25-2) counterclockwise by hand and remove towards the top from the slide (25-1).

2 Removing the beaker adapter

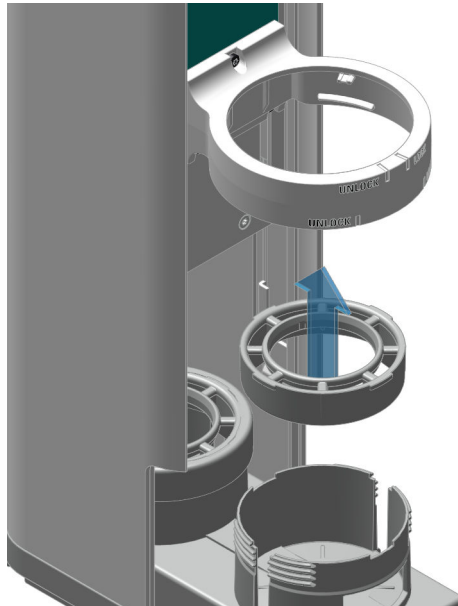

Figure 27 Removing the beaker adapter

Remove the beaker adapter (25-3) out of the slide by hand from above.

3 Inserting the beaker adapter

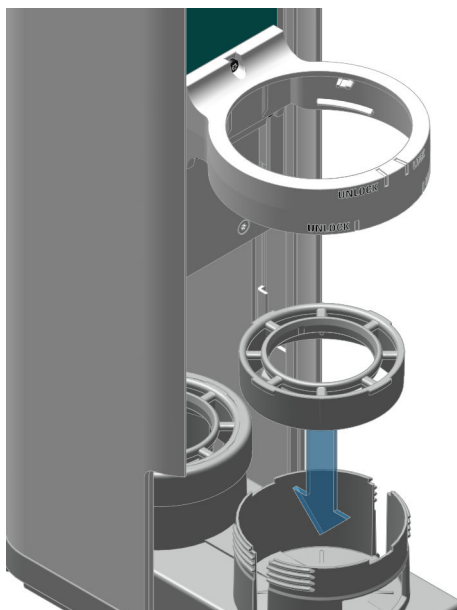

Figure 28 Inserting the beaker adapter

Make sure that the correct values for the beaker diameter and beaker height (see "Available beaker adapters and settings" table) are entered for the respective Pick&Place module in the OMNIS Software. The value can be modified in the **Instruments** area under **Properties / Specific data**.

i If you switch to another beaker size, make sure to also take the titration head into account.

For beakers of 150 mL, we recommend using the 6.01403.060 titration head that is also used for beakers of 200 mL.

Insert the beaker adapter from above into the slide. Rotate the beaker adapter so that its 4 lugs slide into the grooves of the slide.

4 Fastening the ring

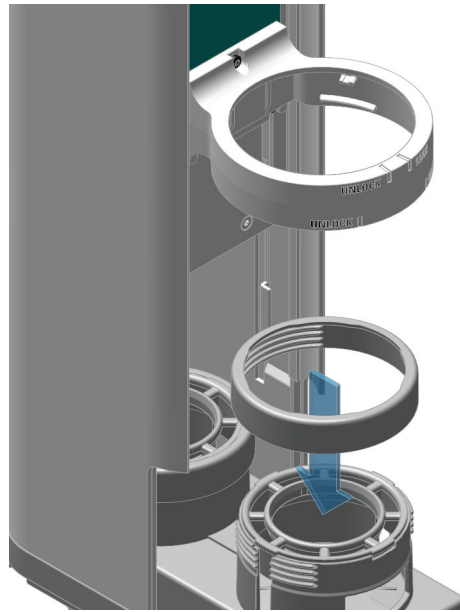

Figure 29 Fastening the ring

Attach the ring by hand to the slide and tighten clockwise.

8.4 Replacing the titration head

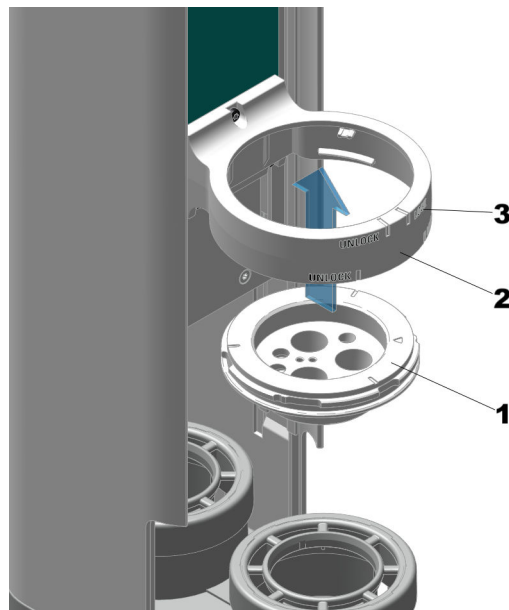

Figure 30 Replacing the titration head

1 Titration head

2 Titration head holder

3 Markings "LOCK" and "UNLOCK"



Replacing the titration head

Prerequisite:

- The sample robot is switched off.
- All of the sensors in the titration head are dismantled.
- The safety shield is dismantled.

1 Removing the titration head

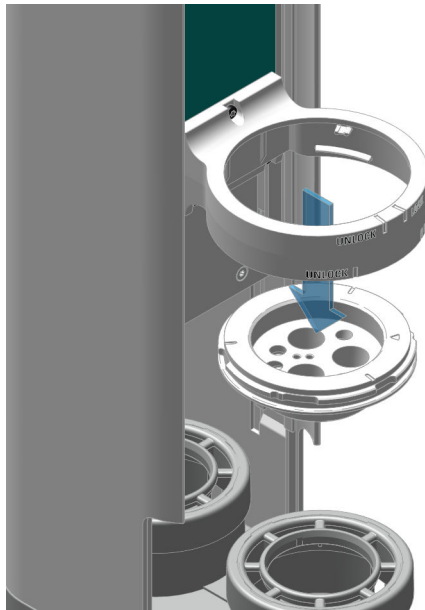

Figure 31 Removing the titration head

- Grip the titration head (30-1) with one hand and rotate it counterclockwise until the marking points to "UNLOCK" (30-3).
- Remove the titration head towards the bottom out of the titration head holder (30-2).



2 Inserting the titration head

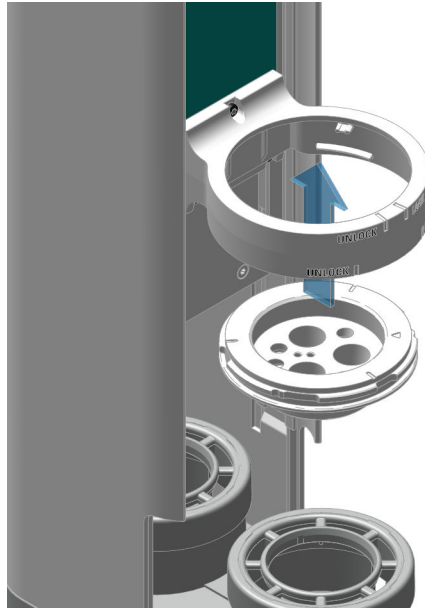

Figure 32 Inserting the titration head

Insert the titration head from the bottom into the titration head holder.

3 Fastening the titration head

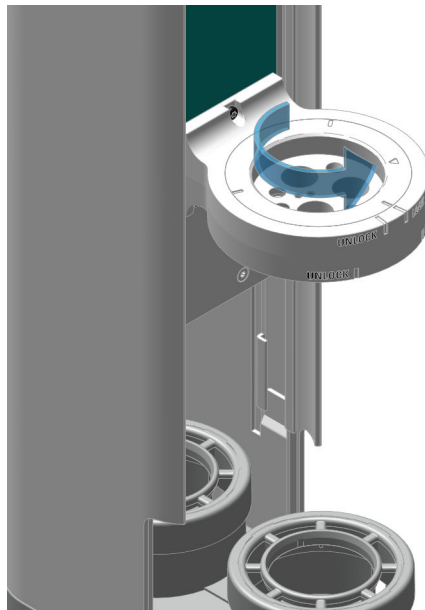

Figure 33 Fastening the titration head

Rotate the titration head by hand until the marking points to "LOCK".

Table 10 Available titration heads



Beaker volume	Stirring propeller	Openings / designations	Article number
75 mL	6.01900.020	4xM10	6.01403.010
75 mL		4xM10 for KFT	6.01403.020
75 mL		2xSGJ14, 1xM10	6.01403.040
120 mL	6.01900.030	3xSGJ14, 4x6.4mm	6.01403.030
120 mL		1xSGJ14, 2xM6, 1xM10, 1x6.4mm	6.01403.050
150 mL	6.01900.010	3xSGJ14, 4x6.4mm	6.01403.060
200 mL	6.01900.030	3xSGJ14, 4x6.4mm	6.01403.060
250 mL	6.01900.010	6xSGJ14, 3xSGJ9	6.01403.000

8.5 Checking the pump tubing

Interval

The pump tubing must be checked each time before starting work.

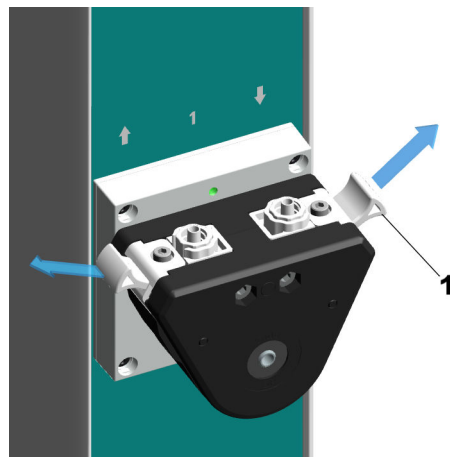

Figure 34 Removing the press clamp

1 Press clamp

Removing the press clamp

Prerequisites:

- The sample robot is disconnected from the power grid.

- 1
 - Pull the press clamp on one side outwards by hand.
 - Pull off the other side.
 - Remove the press clamp.

- 1 Do not fasten or loosen the hex screws of the press clamps.

Checking the pump tubing

Prerequisites:

- The sample robot is disconnected from the power grid.

1 Daily/continuous checking

The pump tubing is comprised of wear parts and is susceptible to leaks and damage.

- Check the pump tubing daily and/or continuously.
- Replace worn and/or damaged pump tubing.
- When replacing pump tubing, also replace the press clamp.

- 1 Perform a visual inspection of the pump tubing. Note any cracking or leaking liquid while doing so.

If the pump tubing should exhibit damage, replace it without delay.

(see "Replacing the pump tubing", chapter 8.6, page 60)

Mounting the press clamp

Prerequisites:

- The sample robot is disconnected from the power grid.

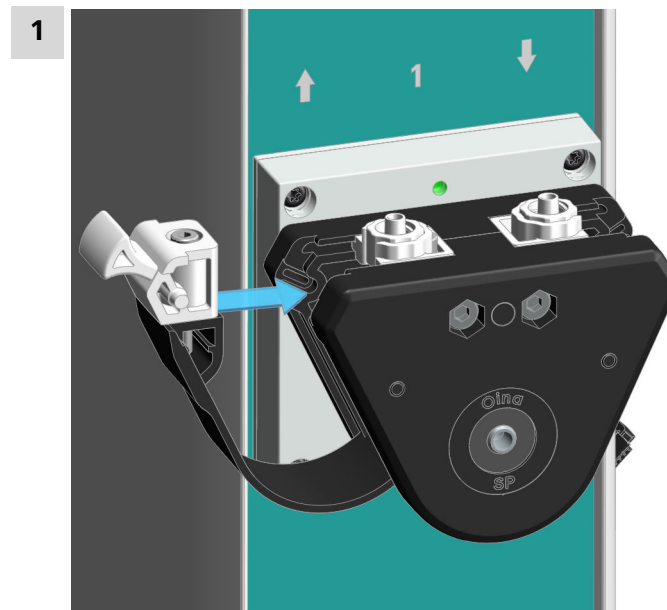

Figure 35 Mounting the press clamp

- Insert one side of the press clamp with the lug into the guide rail provided for this purpose and push it in.



- Plug the other side in as well with the lug in the guide rail and push it in.
- Make sure that the press clamp is placed so that it is flush and positioned cleanly.

8.6 Replacing the pump tubing

- i** Use the following pump tubing:
 - Light-colored tubing from Pharm-A-line™ (6.01801.020) with white press clamp (6.02703.000).

Only pump tubing that has been authorized by Metrohm may be used!

- i** When replacing pump tubing, also replace the press clamp!

Dismantling the pump tubing

Prerequisites:

- The sample robot is disconnected from the power grid.

1 Removing the peristaltic pump tubing

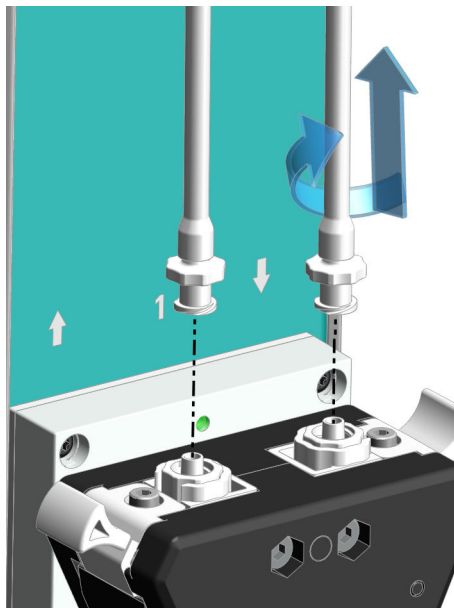

Figure 36 Removing the inlet and outlet tubing

Rotate the tubing counterclockwise and remove it upwards out of the peristaltic pump.

2 Removing the press clamp

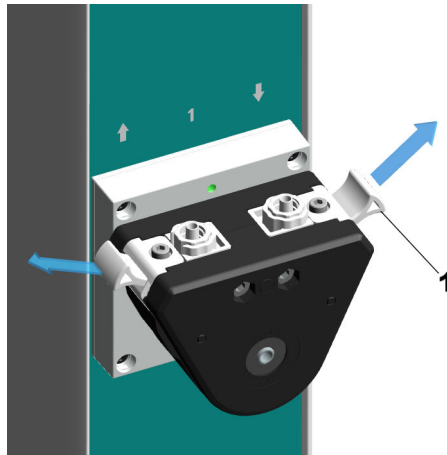

Figure 37 Removing the press clamp

- Pull one side of the press clamp (1) outwards by hand.
- Pull off the other side.
- Remove the press clamp.

3 Removing the pump tubing



Figure 38 Removing the pump tubing

Pull one of the connecting elements of the pump tubing outwards by hand. Afterwards, remove the other side.

- i** The pump tubing is positioned close to the inner rollers for optimum conveyance of the media. It is for that reason that a certain amount of force must be applied for disassembling the first connecting element.
- The pump tubing and its connecting elements are designed for this application of force.

Installing the pump tubing

Prerequisites:

- The sample robot is disconnected from the power grid.
- The pump tubing is dismantled.

1 Inserting the pump tubing

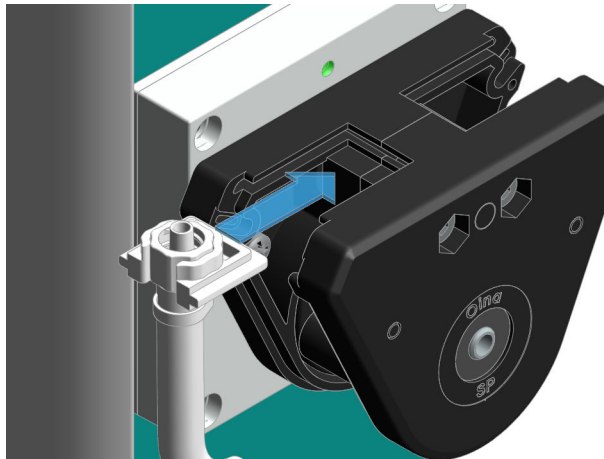

Figure 39 Inserting the pump tubing

Slide one connecting element on one side into the guide rail and up until it stops.

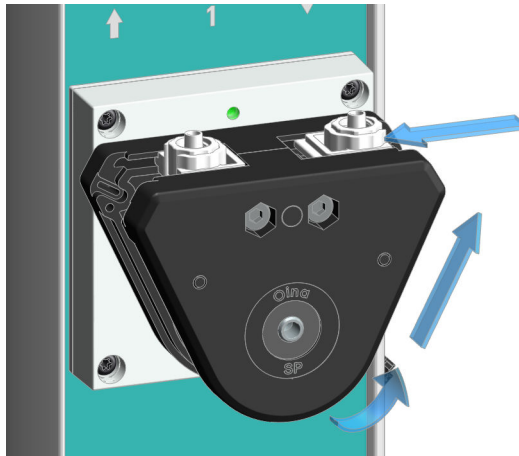

Figure 40 Placing the pump tubing around rollers

Place the pump tubing around the rollers and slide the second connecting element up on the other side until it stops in the guide rail as well.

i The position of the pump tubing must be close and snug to the rollers for optimum conveyance of the media. It is for that reason that a certain amount of force must be applied for assembling the second connecting element.

The pump tubing and its connecting elements are designed for this application of force.

2 Mounting the press clamp

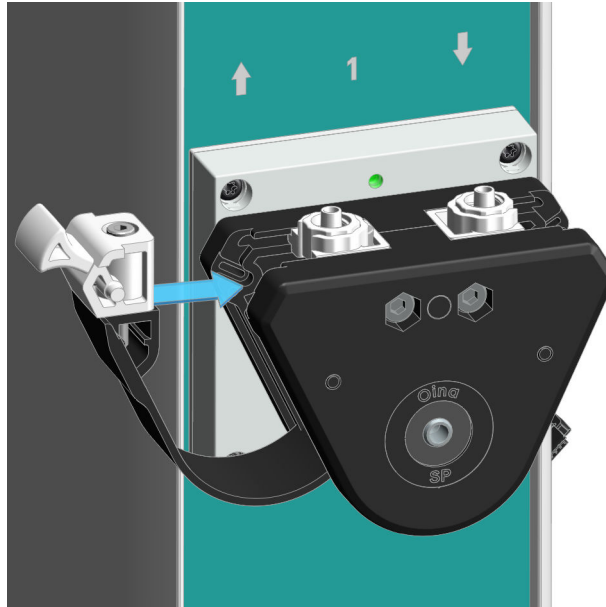

Figure 41 Mounting the press clamp

i Do not fasten or loosen the hex screws of the press clamps.

- Insert one side of the press clamp with the lug into the groove provided for this purpose and push it in.
- Plug the other side in as well with the lug in the groove and push it in.
- Make sure that the press clamp is placed so that it is flush and positioned cleanly.

3 Connecting the tubing with the peristaltic pump

See (see ["Connecting the inlet and outlet tubing", chapter 5.9, page 40](#)).

8.7 Cleaning the product surface

Regularly clean the product to prevent malfunctions and to ensure a long service life.

- Remove spilled chemicals immediately.
- Protect plug connections against contamination.



WARNING

Chemical hazardous substances

Contact with aggressive chemical substances may cause poisoning or chemical burns.

- Wear personal protective equipment (e.g. protective glasses, gloves).
- Use exhaust equipment when working with vaporizing hazardous substances.
- Clean contaminated surfaces.
- Only use detergents that do not cause any unwanted side reactions with the materials to be cleaned.
- Dispose of chemically contaminated materials (e.g. cleaning material) in accordance with regulations.



WARNING

Electrical potential

Contact with electrical potential can cause serious injuries or death.

- Operate the product only if it is in perfect condition. The housing must also be intact.
- Only use the product with the covers fitted.
- Protect live components (e.g. power supply unit, power cord, connection sockets) against moisture.
- Always have maintenance work and repairs on electrical components carried out by a regional Metrohm service representative.

Prerequisite:

- The product is switched off and disconnected from the energy supply.

Required accessories:

- Cleaning cloth (soft, lint-free)
- Water or ethanol

1 Clean the surface with a damp cloth. Remove persistent contamination with ethanol.

2 Wipe the surface with a dry cloth.

3 Clean the connectors with a dry cloth.

9 Troubleshooting

Messages on malfunctions and errors are displayed in the control software or in the embedded software (e.g. on the display of an instrument) and contain the following information:

- Descriptions of causes of malfunctions (e.g. jammed drive)
- Descriptions of problems with the control (e.g. missing or invalid parameter)
- Information on how to solve the problem

System components with status display elements also indicate malfunctions and errors with a red flashing LED.

Troubleshooting on the product is often only possible with the control software or the embedded software (e.g. initializing, moving to a defined position).

See also

System – Signals (chapter 3.6, page 26)

9.1 Opening the gripper manually

Prerequisite:

- The OMNIS Sample Robot Pick&Place stands still.

1



CAUTION

Unsecured sample beakers

If the gripper is opened, then unsecured sample beakers may fall down. Spilled chemicals may result in injuries. The product may be damaged by liquid seeping in.

- Always hold the sample vessel in one hand if the gripper is being opened manually.
- Wear personal protective equipment (e.g. protective glasses, gloves).

Hold the sample beaker in one hand.

2



Hold the on/off switch pressed down for 5 seconds until a dual beep is heard.

The gripper opens and the sample vessel can be removed.



 In the event of a malfunction, sample beakers must always be removed manually. It is not possible to initialize the sample robot if a sample beaker is still in the gripper.

See also

[OMNIS Sample Robot – Indicators and controls \(chapter 3.5, page 25\)](#)

10 Disposal

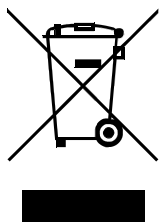

Properly dispose of chemicals and of the product to reduce negative effects on the environment and public health. Local authorities, waste disposal companies or dealers provide more detailed information on disposal. Observe the WEEE EU directive (WEEE = Waste Electrical and Electronic Equipment) for the proper disposal of waste electronic equipment within the European Union.



11 Technical specifications

11.1 Ambient conditions

Nominal function range	+5 to +45 °C	at max. 80% relative humidity, non-condensing
-------------------------------	--------------	---

Storage	+5 to +45 °C	
----------------	--------------	--

11.2 Main module – Energy supply

Nominal voltage range	100–240 VAC	
------------------------------	-------------	--

Nominal frequency range	50–60 Hz	
--------------------------------	----------	--

Power consumption	max. 200 W	
--------------------------	------------	--

Protection

<i>Internal fuse</i>	4 ATH	cannot be replaced by the user
----------------------	-------	--------------------------------

11.3 Pick&Place module – Energy supply

Nominal voltage	24 VDC	internal
------------------------	--------	----------

Power consumption	max. 30 W	
--------------------------	-----------	--

Protection

<i>Internal fuse</i>	1.5 ATH	cannot be replaced by the user
----------------------	---------	--------------------------------



11.4 Peristaltic pump module – Energy supply

Nominal voltage	24 VDC	internal
Power consumption		
<i>Peristaltic pump</i>	max. 10 W	per pump
Protection		
<i>Internal fuse</i>	1.5 ATH	cannot be replaced by the user

11.5 OMNIS sample rack – Energy supply

Nominal voltage	5 VDC	internal
Power consumption	max. 0.5 W	

11.6 OMNIS Sample Robot Pick&Place – Dimensions

The OMNIS Sample Robot S Pick&Place consists of 1 main module Pick&Place S, 1 Pick&Place module and 1 peristaltic pump module (2-channel).

Measurements

<i>Width</i>	558 mm
<i>Height</i>	765 mm
<i>Depth</i>	564 mm

Weight

29.3 kg



11.7 Main module Pick&Place – Dimensions

Measurements

Width

Main module S	558 mm
Main module M	1,161 mm
Main module L	1,441 mm

Height

Main module S, M, L	
Without workstation	585 mm
Main module S, M, L	
With workstation	758 mm

Depth

Main module S	
Without workstation	564 mm
With workstation	604 mm
Main module M, L	564 mm

Weight

Main module S	
Without workstation	21.0 kg
Main module M	
Without workstation	21.5 kg
Main module L	
Without workstation	22.7 kg

11.8 Pick&Place module – Dimensions

Measurements

<i>Width</i>	92 mm
<i>Height</i>	746 mm
<i>Depth</i>	289 mm

Weight

Without magnetic stirrer	4.0 kg
With magnetic stirrer	4.4 kg

11.9 Peristaltic pump module – Dimensions

Measurements

<i>Width</i>	92 mm
<i>Height</i>	585 mm
<i>Depth</i>	
With 2 pumps	289 mm
With 4 pumps	320 mm

Weight

<i>Without lid tray</i>		
With 2 pumps	4.3 kg	
With 4 pumps	5.6 kg	
<i>With lid tray</i>		for working with covered sample beakers
With 2 pumps	4.8 kg	
With 4 pumps	6.0 kg	
<i>With lid tray</i>		for working with covered sample beakers
Dummy panel	4.0 kg	without pumps



11.10 OMNIS sample rack – Dimensions

Measurements

<i>Width</i>	277 mm
<i>Height</i>	125 mm
<i>Depth</i>	277 mm

Weight

<i>Versions</i>	
9 x 250 mL	1,038 g
9 x 200 mL	1,086 g
9 x 150 mL	1,620 g
16 x 120 mL	1,051 g
25 x 75 mL	1,071 g

11.11 Rack base / module base – Dimensions

Measurements

<i>Width</i>	280 mm
<i>Height</i>	115 mm
<i>Depth</i>	564 mm

Weight

<i>Rack base</i>	3.9 kg
<i>Module base M/L</i>	4.6 kg

11.12 Main module Pick&Place – Housing

Materials

<i>Lid</i>	PBT	poly(butylene terephthalate)
<i>Back panel</i>	AW-5754 H12 / H22	aluminum, coated
<i>Base</i>	AlSi12Cu1	aluminum, coated
<i>Enclosure</i>	PBT	poly(butylene terephthalate)
	PP	polypropylene
<i>Front foils</i>	PET	poly(ethylene terephthalate), mat

IP degree of protection IP 20

11.13 Pick&Place module – Housing

Materials

<i>Lid</i>	PBT	poly(butylene terephthalate)
<i>Back panel</i>	1.4301	stainless steel, coated
<i>Base</i>	PBT	poly(butylene terephthalate)
<i>Enclosure</i>	PP	polypropylene

IP degree of protection IP 20



11.14 Peristaltic pump module – Housing

Materials

<i>Lid</i>	PBT	poly(butylene terephthalate)
<i>Back panel</i>	AW-5754 H12 / H22	aluminum, coated
<i>Base</i>	PBT	poly(butylene terephthalate)
<i>Enclosure</i>	PP	polypropylene
<i>Lid tray</i>	AW-5754 H12 / H22	aluminum, coated

IP degree of protection IP 20

11.15 Module base – Housing

Materials

<i>Cover</i>	AW-5754 H12 / H22	aluminum, coated
<i>Base</i>	AlSi12Cu	aluminum, coated

IP degree of protection IP 40

11.16 Rack base – Housing

Materials

<i>Cover</i>	AW-5754 H12 / H22	aluminum, coated
<i>Base</i>	AlSi12Cu	aluminum, coated

IP degree of protection IP 20

11.17 OMNIS sample rack – Housing

Materials	PP	polypropylene
IP degree of protection	IP 40	

11.18 Main module – Connectors specifications

Energy supply		via power connection
<i>Socket</i>		IEC 60320, type C14, 10 A
Power cord		
Length	max. 2 m	
Number of conductors	3	with protective ground
Conductor cross-section	min. 0.75 mm ² / 18 AWG	
Plug		
Instrument side		IEC 60320, type C13, 10 A
Building side		country-specific
MDL	Metrohm Device Link	4 connectors
HID	Human Interactive Device	
LAN	Local Area Network	
<i>Type</i>	Ethernet CAT 6	
<i>Socket</i>	RJ45	shielded
<i>Cable type</i>	(min. FFTP)	shielded
<i>Cable length</i>	max. 10 m	from Metrohm accessories
Contacts	4	Contact surfaces for OMNIS sample rack



11.19 Rack base – Connectors specifications

Contacts	4	Contact surfaces for rack base
----------	---	--------------------------------

11.20 OMNIS sample rack – Connectors specifications

Contacts	4	Spring contacts
----------	---	-----------------

11.21 Modules – Connectors specifications

Energy supply		internally via MDL
---------------	--	--------------------

MDL	Metrohm Device Link	4 internal connectors
-----	---------------------	-----------------------

11.22 Display specifications

Status display	LED	multi-colored
----------------	-----	---------------

11.23 Peristaltic pump module – Liquid Handling specifications

Working Module Pump

<i>Type</i>		peristaltic
-------------	--	-------------

<i>Number</i>	2 / 4	
---------------	-------	--

Pump

<i>Add</i>	150 mL/min	
------------	------------	--

<i>Aspirate</i>	300 mL/min	
-----------------	------------	--



11.24 Magnetic stirrer – Specifications

OMNIS product version		with attached magnetic stirrer
Adjustment range for rotational speed	+1 to +15	Rotation in counter-clockwise direction (seen from above)
	-1 to -15	Rotation in clockwise direction (seen from above)
Rotational speed change per step	120 rpm	
Maximum rotational speed	1,800 rpm	
Stirring bar lengths	8, 12, 16, 25, 30 mm	

11.25 OMNIS Sample Robot Pick&Place – Sample handling specifications

Robot arm		
<i>Load</i>	3.7 N	typical
<i>Speed</i>	15 mm/s - 75 mm/s	
Gripper type with beaker diameter		
<i>Range</i>	25.6 mm - 71.6 mm	from Metrohm accessories
Rack positions		
<i>Sample Robot S</i>	1 - 2	
<i>Sample Robot M</i>	1 - 5	
<i>Sample Robot L</i>	1 - 7	



11.26 Pick&Place module – Sample handling specifications

Pick&Place workstation

Magnetic stirrer

√ / –

yes / no

11.27 OMNIS sample rack – Sample processing specifications

Versions

Number of beaker positions

9, 16, 25

from Metrohm accessories