

Measuring Module Analog

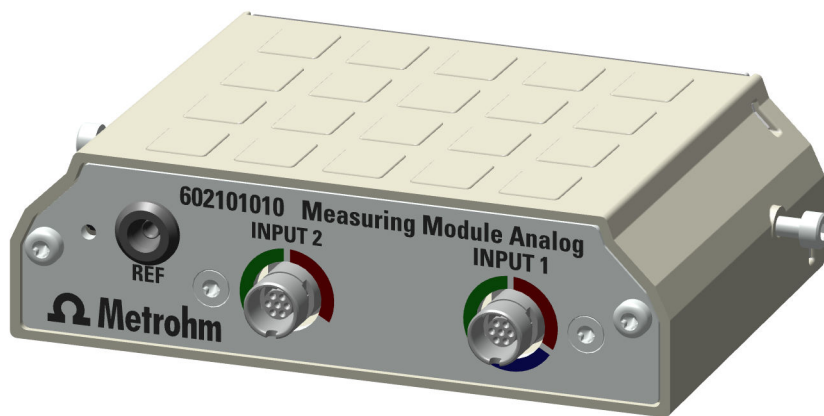

6.02101.010

Product manual

8.0108.8012EN / 2022-01-12



Metrohm AG
Ionenstrasse
CH-9100 Herisau
Switzerland
+41 71 353 85 85
info@metrohm.com
www.metrohm.com

Measuring Module Analog

6.02101.010

Product manual

8.0108.8012EN /
2022-01-12

Technical Communication
Metrohm AG
CH-9100 Herisau

This documentation is protected by copyright. All rights reserved.

This documentation has been prepared with great care. However, errors can never be entirely ruled out. Please send comments regarding possible errors to the address above.

Disclaimer

Deficiencies arising from circumstances that are not the responsibility of Metrohm, such as improper storage or improper use, etc., are expressly excluded from the warranty. Unauthorized modifications to the product (e.g. conversions or attachments) exclude any liability on the part of the manufacturer for resulting damage and its consequences. Instructions and notes in the Metrohm product documentation must be strictly followed. Otherwise, Metrohm's liability is excluded.

Table of contents

1	Overview	1
1.1	Measuring Module Analog – Product description	1
1.2	Measuring Module Analog – Product versions	1
1.3	Symbols and conventions	2
1.4	Further information	2
1.5	Accessories	2
2	Safety	4
2.1	Intended use	4
2.2	Responsibility of the operator	4
2.3	Requirements for operating personnel	5
2.4	Safety instructions	5
2.4.1	Danger from electrical potential	5
2.4.2	Danger from biological and chemical hazardous substances	5
2.4.3	Danger from highly flammable substances	6
2.5	Design of warning messages	6
2.6	Meaning of warning signs	7
3	Functional description	9
3.1	Measuring Module Analog – Overview	9
3.2	Measuring Module Analog – Functional description	10
3.3	System – Signals	10
3.4	Measuring Module Analog – Interfaces	10
4	Delivery and packaging	12
4.1	Delivery	12
4.2	Packaging	12
5	After installation	13
5.1	Mounting the measuring module	13
5.2	Connecting the sensor	16
6	Operation and control	17
6.1	Operation	17



- 7 Maintenance 18**
 - 7.1 Maintenance 18
 - 7.2 Cleaning the product surface 18
- 8 Troubleshooting 20**
- 9 Disposal 21**
- 10 Technical specifications 22**
 - 10.1 Ambient conditions 22
 - 10.2 Measuring module – Energy supply 22
 - 10.3 Measuring module – Dimensions 22
 - 10.4 Measuring module – Housing 23
 - 10.5 Measuring Module Analog – Connectors specifications 23
 - 10.6 Measuring Module Analog – Display specifications 24
 - 10.7 Measuring Module Analog – Measuring specifications .. 24

1 Overview

1.1 Measuring Module Analog – Product description

The Measuring Module Analog is used as a measuring input for analog electrodes on an OMNIS Titrator or an OMNIS Titration Module.

1.2 Measuring Module Analog – Product versions

The product is available in the following versions:

Table 1 Product versions

Article number	Designation
6.02101.010	Measuring Module Analog

The article number and serial number for identifying the product can be found on the type plate:

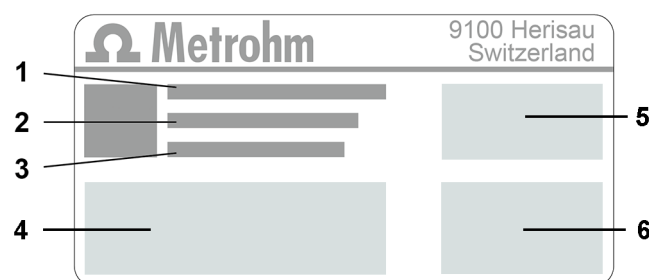

1	(01) = Article number in accordance with GS1 standard	2	(21) = Serial number
3	(240) = Metrohm article number	4	Certification
5	Certification	6	Technical specifications



1.3 Symbols and conventions

The following formatting may appear in the documentation:

(5-12)	Cross-reference to figure legend The first number refers to the figure number. The second number refers to the product part in the figure.
1	Instruction step Numbers indicate the order of the instructions steps.
Method	Names of parameters, menu items, tabs and dialogs
File ► New	Menu path
[Continue]	Button or key

1.4 Further information

The Metrohm Knowledge Base <https://guide.metrohm.com> always provides the current version of this document. Further instructions, leaflets, release notes etc. may be available, depending on the product. You can directly access the required information or the associated PDF document using the full-text search function and filters.

1.5 Accessories

Up-to-date information on the scope of delivery and on optional accessories can be found on the Metrohm website. Download this information as follows:

Downloading the accessories list

- 1 Go to <https://www.metrohm.com>.
- 2 Enter the article number of the product (e.g. **2.1001.0010**) into the search field.
The search result is displayed.
- 3 Click on the product.
Detailed information regarding the product is shown on various tabs.

4 On the **Included parts** tab, click the link to download the PDF.
The PDF file with the accessories data is loaded.

 Metrohm recommends downloading the accessories list from the Internet and keeping it for reference purposes.

2.3 Requirements for operating personnel

Only qualified personnel may operate the product. Qualified personnel are persons who meet the following requirements:

- Basic regulations on occupational safety and accident prevention for chemical laboratories are known and complied with.
- Knowledge of handling hazardous chemicals is present. Personnel have the ability to recognize and avoid potential dangers.
- Knowledge regarding the application of fire prevention measures for laboratories is available.
- Safety-relevant information is communicated and understood. The personnel can operate the product safely.
- The user documentation has been read and understood. The personnel operate the product according to the instructions in the user documentation.

2.4 Safety instructions

2.4.1 Danger from electrical potential

Contact with electrical potential can cause serious injuries or death. To avoid danger from electrical potential, observe the following:

- Operate the product only if it is in perfect condition. The housing must also be intact.
- Only use the product with the covers fitted. If covers are damaged or missing, disconnect the product from the energy supply and contact the regional Metrohm service representative.
- Protect live components (e.g. power supply unit, power cord, connection sockets) against moisture.
- Always have maintenance work and repairs on electrical components carried out by a regional Metrohm service representative.
- Disconnect the product from the energy supply immediately if at least one of the following cases occurs:
 - The housing is damaged or open.
 - Live parts are damaged.
 - Moisture penetrates.

2.4.2 Danger from biological and chemical hazardous substances

Contact with biological hazardous substances may cause poisoning from toxins or infections from microorganisms. Contact with aggressive chemical substances may cause poisoning or chemical burns. To avoid danger from biological or chemical hazardous substances, observe the following:

DANGER

Type or source of danger

Consequences when not observing the notice: An irreversible injury that may result in death is very probable.

- Measures to avoid the danger

WARNING

Type or source of danger

Consequences when not observing the notice: A serious injury that may result in death is probable.

- Measures to avoid the danger

CAUTION

Type or source of danger







Consequences when not observing the notice: A minor to moderate injury is probable.

- Measures to avoid the danger





2.6 Meaning of warning signs

This documentation uses the following warning signs:

Table 2 Warning sign according to ISO 7010

Warning sign	Meaning
	General warning sign
	Warning of electrical voltage
	Warning of hand injuries
	Warning of sharp object
	Warning of hot surface
	Warning of biological hazard
	Warning of toxic materials



Warning sign	Meaning
	Warning of flammable materials
	Warning of corrosive substances
	Warning of optical radiation
	Warning of laser beams

Depending on the intended use of the product, the corresponding warning sign stickers must be placed on the product.

3 Functional description

3.1 Measuring Module Analog – Overview

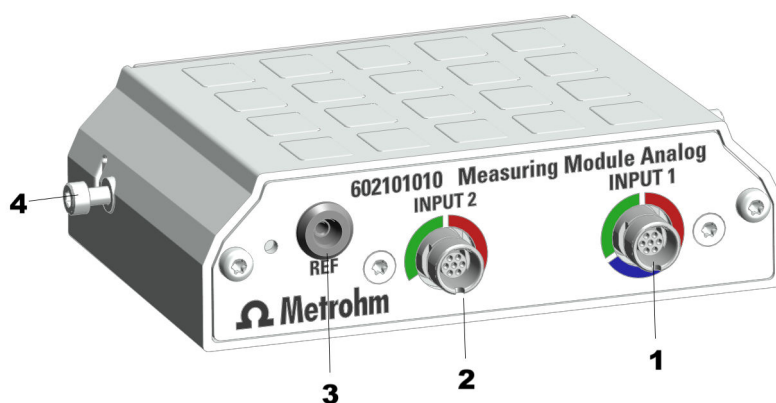

Figure 1 Measuring Module Analog – Overview

1 INPUT 1

Connection socket for potentiometric sensors (green coding), temperature sensors (red coding) and polarizable sensors (blue coding)

2 INPUT 2

Connection socket for potentiometric sensors (green coding) and temperature sensors (red coding)

3 REF

Connection socket for reference electrodes

4 Fastening screws

Fastening screws, left and right. These fasten the measuring module in the housing and ground the electronics.









3.2 Measuring Module Analog – Functional description

The Measuring Module Analog contains the electronics necessary for the use of analog sensors. Analog electrodes and analog reference electrodes can be plugged into its connection sockets.

3.3 System – Signals

System components with status indicators show their operating status with colors and/or flashing patterns. The meaning of the colors and flashing patterns is explained in the following table.

Visual signal		Meaning
	LED lights up yellow.	System start or initialization
	LED flashes yellow (slowly).	Ready for connection setup or locking
	LED flashes yellow (fast).	Connection setup started or locking underway
	LED lights up green.	Ready for operation
	LED flashes green (slowly).	In operation
	LED flashes red (fast).	Malfunction or error

Some system components only use part of the explained flashing patterns.

3.4 Measuring Module Analog – Interfaces

The Measuring Module Analog has 3 measuring inputs for analog electrodes.

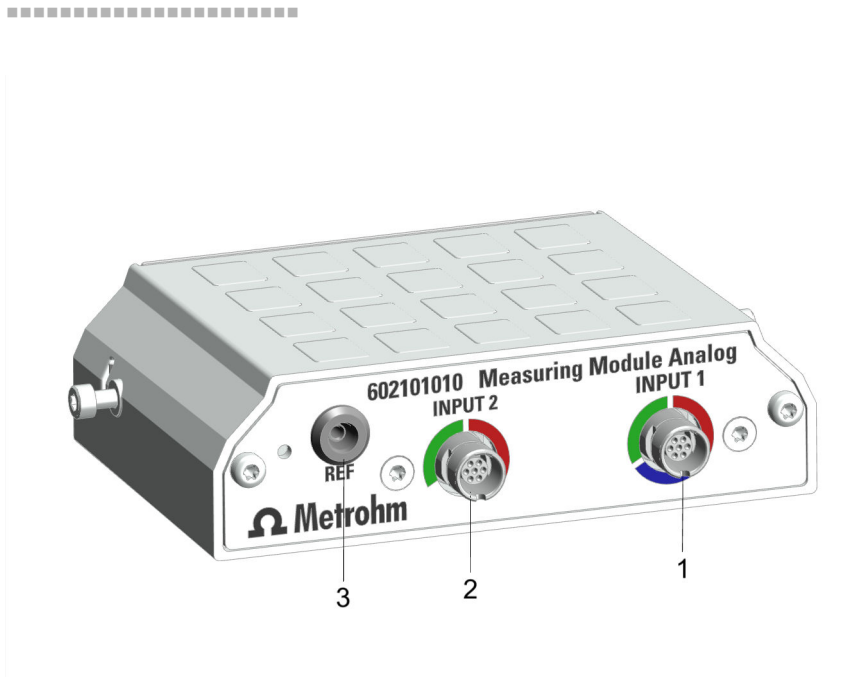

Figure 2 Measuring Module Analog – Measuring inputs

1	INPUT 1	2	INPUT 2
3	REF		

Measuring inputs INPUT 1 and INPUT 2

The measuring inputs **INPUT 1** and **INPUT 2** are marked with colored circle segments. The markings indicate that only certain types of electrode cables may be plugged into the connection socket:

Table 3 Meaning of the colors

Red	The connector supports temperature sensors.
Blue	The connector supports polarized sensors.
Green	The connector supports potentiometric sensors.

REF measuring input

Reference electrodes can be plugged into the **REF** measuring input.



4 Delivery and packaging

4.1 Delivery

Inspect the delivery immediately upon receipt:

- Check the delivery against the delivery note to ensure completeness.
- Check the product for damage.
- If the delivery is incomplete or damaged, contact your regional Metrohm representative.

4.2 Packaging

The product and accessories are supplied in protective special packaging. Keep this packaging to ensure safe transportation of the product. If a transport locking device is present, keep this as well for future reuse.

5 After installation

5.1 Mounting the measuring module

The measuring module is supplied with mounted fastening screws. These fastening screws are used to secure the measuring module in the instrument to ensure trouble-free operation.

1 Opening the lid

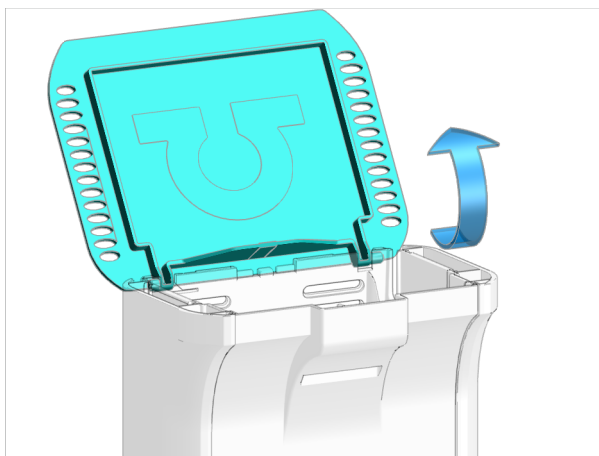

- Open the lid.

2 Removing the side parts

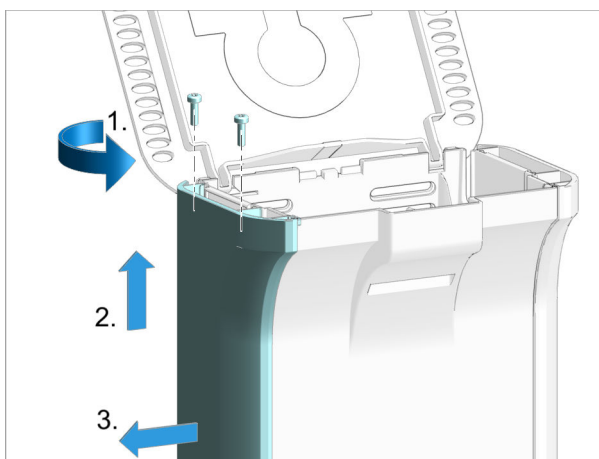

Carry out the following steps on **both sides** of the instrument.

- Remove the 2 screws from above using the hex key.



- Push the side covering upwards until it can be removed from the side.
- Remove the side covering to the side.

3 Removing the fastening screws

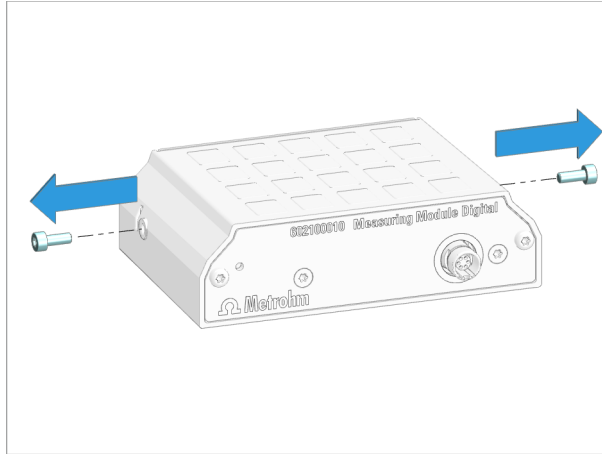

- Remove the 2 fastening screws from the measuring module using the hex key.

4 Inserting the measuring module

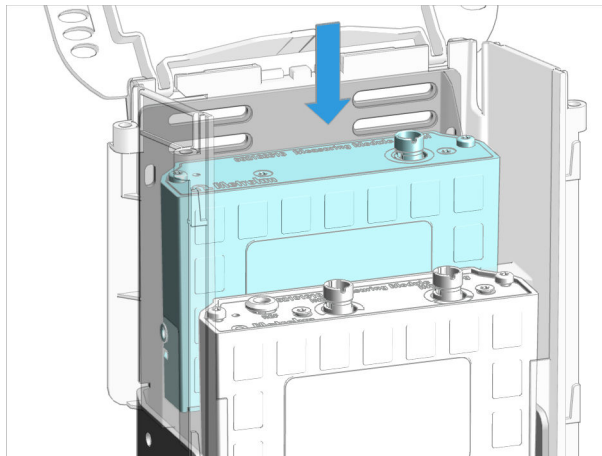

- Insert the measuring module into an empty slot. The slots are designated with 1 (rear) and 2 (front).



5 Attaching the measuring module

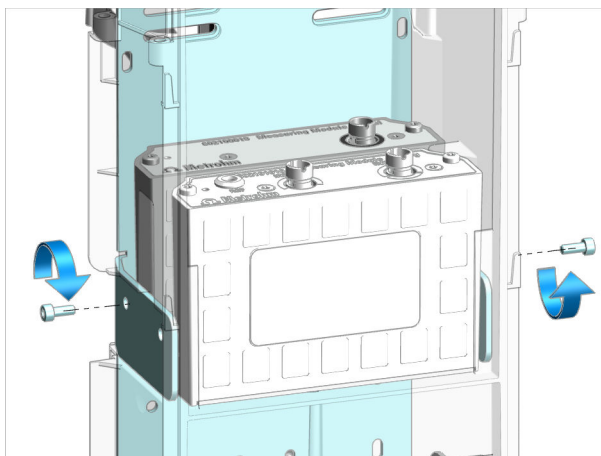

- Insert the fastening screws. Tighten the measuring module to the housing from **both sides** using the hex key.

6 Mounting the side parts

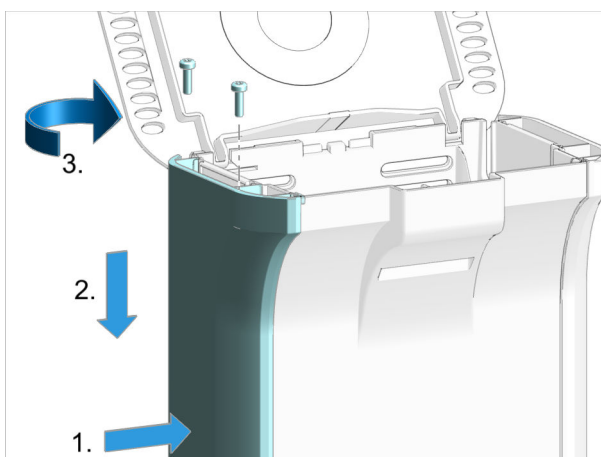

Carry out the following steps on **both sides** of the instrument.

- Position the side covering from the side in an elevated position.
- Insert the side covering into the guide rail and push it downwards.
- Insert the 2 screws and tighten them from above using the hex key.

5.2 Connecting the sensor

1 Plugging in the electrode cable

- Open the lid of the instrument.
- Align the red dot on the plug with the groove on the connection socket.
- Plug in the plug of the electrode cable until you can feel it snap in.

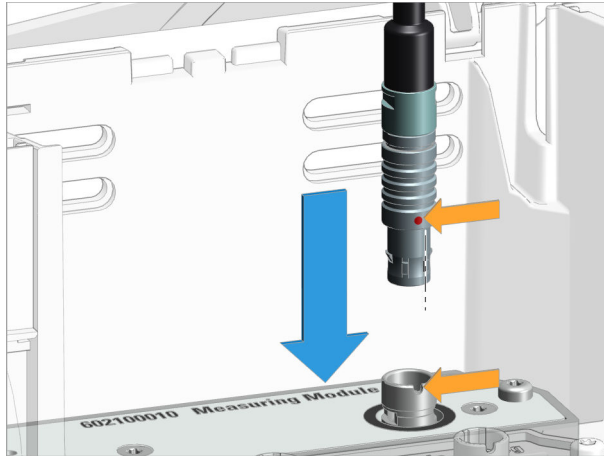

- i** If the plug cannot be inserted easily, rotate the plug to the right or left using light pressure until it latches in the socket.

2 Guiding out the cable

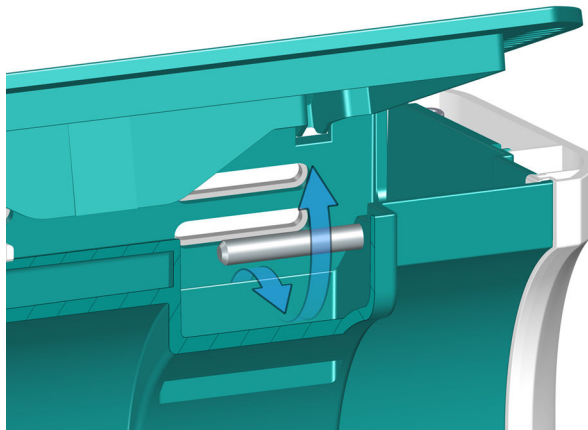

- Guide the cable out under the bar.
- Close the lid.

6 Operation and control

6.1 Operation

The product can be operated via the OMNIS Software. Further information on the OMNIS Software under [OMNIS Help](#).



WARNING

Electrical potential

Contact with electrical potential can cause serious injuries or death.

- Operate the product only if it is in perfect condition. The housing must also be intact.
- Only use the product with the covers fitted.
- Protect live components (e.g. power supply unit, power cord, connection sockets) against moisture.
- Always have maintenance work and repairs on electrical components carried out by a regional Metrohm service representative.

Prerequisite:

- The product is switched off and disconnected from the energy supply.

Required accessories:

- Cleaning cloth (soft, lint-free)
- Water or ethanol

1 Clean the surface with a damp cloth. Remove persistent contamination with ethanol.

2 Wipe the surface with a dry cloth.

3 Clean the connectors with a dry cloth.

8 Troubleshooting

Messages on malfunctions and errors are displayed in the control software or in the embedded software (e.g. on the display of an instrument) and contain the following information:

- Descriptions of causes of malfunctions (e.g. jammed drive)
- Descriptions of problems with the control (e.g. missing or invalid parameter)
- Information on how to solve the problem

System components with status display elements also indicate malfunctions and errors with a red flashing LED.

Troubleshooting on the product is often only possible with the control software or the embedded software (e.g. initializing, moving to a defined position).

See also

[System – Signals \(chapter 3.3, page 10\)](#)

9 Disposal

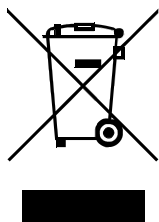

Properly dispose of chemicals and of the product to reduce negative effects on the environment and public health. Local authorities, waste disposal companies or dealers provide more detailed information on disposal. Observe the WEEE EU directive (WEEE = Waste Electrical and Electronic Equipment) for the proper disposal of waste electronic equipment within the European Union.



10 Technical specifications

10.1 Ambient conditions

Nominal function range	+5 to +45 °C	at max. 80% relative humidity, non-condensing
-------------------------------	--------------	---

Storage	+5 to +45 °C
----------------	--------------

10.2 Measuring module – Energy supply

Power consumption	max. 0.6 W	-
--------------------------	------------	---

Energy transmission	-	inductive coupling
----------------------------	---	--------------------

10.3 Measuring module – Dimensions

Measurements

<i>Width</i>	105 mm
--------------	--------

<i>Height</i>	31 mm
---------------	-------

<i>Depth</i>	72 mm
--------------	-------

Weight	approx. 420 g
---------------	---------------

10.4 Measuring module – Housing

Materials

<i>Lid</i>	AW-5754 H12 / H22	aluminum, coated
<i>Back panel</i>	PBT	poly(butylene terephthalate)
<i>Enclosure</i>	GD-ZnAl4Cu1	zinc die cast, nickel-plated

IP degree of protection IP 40

10.5 Measuring Module Analog – Connectors specifications

Measuring inputs

INPUT 1

Socket		round plug 7-pin, size 0, 45°
Potentiometric	pH, ISE, Redox	measuring input for potentiometric electrodes
Temperature	Temp.	measuring input for temperature sensors of the Pt1000 or NTC type for automatic temperature compensation
Polarizer	Pol.	measuring input for polarizable electrodes

INPUT 2

Socket		round plug 7-pin, size 0, 45°
Potentiometric	pH, ISE, Redox	measuring input for potentiometric electrodes



Temperature	Temp.	measuring input for temperature sensors of the Pt1000 or NTC type for automatic temperature compensation
REF		reference potential
Type (INPUT 1 - INPUT 2)	2 mm pH, ISE, Redox	potentiometric differential measurement, with respect to REF

10.6 Measuring Module Analog – Display specifications

Status display	LED	green-red
----------------	-----	-----------

10.7 Measuring Module Analog – Measuring specifications

Potentiometric

Measuring range	-2,400 to +2,400 mV	
Resolution	1.56 μ V	
Measuring accuracy	± 0.5 mV	in the measuring range -2,000 mV to +2,000 mV
Input resistance	$\geq 1 \cdot 10^{12} \Omega$	
Offset current	$\leq \pm 1 \cdot 10^{-12}$ A	

Temperature

Pt1000		
Measuring range	-150 to +250 °C	
Resolution	approx. 0.002 °C	
Measuring accuracy	± 0.4 °C	in the measuring range -20.0 to +150.0 °C

Polarizer

I_{pol DC}

Polarization current	-200.0 to +200.0 μ A	adjustable in 0.5 μ A steps
Measuring range	-2,400 to +2,400 mV	
Measuring resolution	0.1 mV	

Potentiometric differential measurement

<i>Measuring range</i>	-2,400 to +2,400 mV	
<i>Measuring resolution</i>	1.56 μ V	
<i>Measuring accuracy</i>	\pm 1.0 mV	in the measuring range -2,000 mV to +2,000 mV

Reference conditions

<i>Relative humidity</i>	\leq 60%	
<i>Ambient temperature</i>	+25 °C (\pm 3 °C)	
<i>Instrument status</i>		min. 30 minutes in operation

Measuring accuracy

applies for all measuring ranges without sensor error, under reference conditions, measuring interval 100 ms