

Installation instructions TitrIC flex II

The TitrIC flex II system is used for the fully automatic analysis of water samples using direct measurement, titration, and ion chromatography. The following parameters are determined within a very short time: temperature, conductivity, pH, acid capacity, and in parallel—the concentrations of individual anions and cations with the resulting water hardness and ion balance. Other Metrohm instruments can be incorporated in the existing system at any time to measure additional parameters.

Analytical sequence

The sample is transferred from the first Pick&Place Module to two 930 Compact IC Flex systems for the anion and cation analysis. At the same time, the conductivity is measured. Following this measurement, a sample volume of 100 mL is transferred into the sample beaker of the second Pick&Place. Afterwards the temperature, pH, and acid capacity (p and m values) of the sample are determined.

This entire procedure is controlled by the MagIC Net software. The user only enters the sample position and sample identification into MagIC Net. All liquid handling steps as well as the titration part are performed by OMNIS. MagIC Net triggers the individual sequences in OMNIS and receives the titration results via RS-232.

All data is summarized in a joint database containing all MagIC Net results as well as the numerical values from OMNIS.



Figure 1: TitrIC flex II system

Table of contents

Parts list	2
1. Installation	4
1.1. Software	4
1.2. Accessory Kit: Vario/Flex Basic (6.5000.000)	4
1.3. Accessory Kit: Vario/Flex ONE (6.5000.010)	5
1.4. IC Equipment: Dosino Regeneration (6.5330.190)	5
1.5. IC equipment: Inline Ultrafiltration 2 - pull mode (6.05330.010)	6
1.6. Setup and connection of the two ICs	6
1.7. Sample Robot S WSM	7
1.7.1. Rear of the Sample Robot S	8
1.7.2. Front of the Sample Robot S WSM	9
1.8. Titration head WS2 (6.01403.030)	10
1.9. Titration head WS3 (6.01403.070)	10
1.10. 800 Dosino & 50 mL 807 Dosing Unit	10
1.11. Conductivity (6.0915.100)	11
1.12. Titrator	11
1.12.1. 20 mL Cylinder Unit (6.1580.220)	11
1.12.2. dAquatrode plus with Pt 1000 (6.00202.300)	11
1.13. 856 Conductometer (2.856.0010)	11
1.13.1. 5-ring conductivity measuring cell (6.0915.100)	11
2. Software	11
2.1. MagIC Net	12
2.1.1. Devices	12
2.1.2. Modifications to the method	12
2.1.3. Workplace setup	13
2.2. OMNIS	14
2.2.1. Adjustment of the instruments	15
2.2.2. Solution/807 Dosing Unit	15
2.2.3. Solution/Cylinder unit OMNIS	15
2.2.4. RS-232	16
2.2.5. OP template	16

2.2.6.	Import OP template.....	16
2.2.7.	Work system	16
2.2.8.	Replacement of functional units.....	17
2.2.9.	Sensors.....	17
2.2.10.	Solutions.....	17
2.2.11.	Samples work area	18
3.	TitriC flex– Upgrade options.....	18
4.	TitriC flex II – Flow chart.....	19

Parts list

TitriC flex II parts list:

Nr	Article no.	Article designation
IC		
1	2.930.2560	930 Compact IC Flex Oven/SeS/PP /Deg
1	2.930.2160	930 Compact IC Flex Oven/Deg
2	2.850.9010	IC Conductivity Detector
1	6.05330.010	IC equipment: Inline Ultrafiltration 2 - pull mode
1	6.02057.120	Ultrafiltration cell 2 holder, stand-alone
1	6.5330.190	IC equipment: Dosino regeneration
1	2.800.0010	800 Dosino
1	6.2755.000	Tubing cartridge
Sample Robot		
1	2.1024.0030	OMNIS Workstation Module (2T/4P)
1	2.1010.0120	OMNIS Main Module S - WSM
1	2.1006.0010	Rod Stirrer "Sample Robot"
1	6.02107.000	Network cable, 1 m
Conductometry		
1	2.856.0010	856 Conductivity Module
1	6.0915.100	5-ring conductivity measuring cell c = 0.7 cm ⁻¹ with Pt1000 (fixed cable)
1	6.2151.000	Cable USB A – mini-DIN 8-pin
p and m value titration (pH measurement)		
1	2.1001.0210	OMNIS Advanced Titrator without stirrer
1	6.03001.220	OMNIS 20 mL cylinder unit
1	6.00202.300	dAquatrode Plus with Pt1000
1	6.02100.010	Digital measuring module

1	6.02104.310	Electrode cable plug-in head Q / plug P, 1.5 m
1	6.02107.010	Network cable, 2 m
Liquid Handling		
1	2.800.0010	800 Dosino
1	6.1580.250	807 Dosing Unit 50 mL
1	6.1808.280	Adapter Dosino port 4, M6 inner
1	6.1618.020	Thread adapter S 40 to GL 45
1	6.2744.080	M6 thread / UNF 10/32 adapter
1	6.1543.040	Micro tip M6 thread
1	6.1808.040	Thread adapter M6 outer / M8 inner
Connection tubing		
1	6.1805.120	FEP tubing / M6 / 100 cm
1	6.1805.030	FEP tubing / M6 / 150 cm
2	6.1805.110	FEP tubing / M6 / 80 cm
License		
1	6.06000.000	OMNIS Software storage device
2	6.06002.010	OMNIS instruments license: 1 license
1	6.06003.012	OMNIS stand-alone license with 2 instrument licenses
1	6.6059.4x1	MagIC Net 4.x Professional CD: 1 license
RS-232 Communication MagIC - OMNIS		
1	6.2134.040	Connecting cable RS-232 to IMP-PC (DBp)
2	6.2148.050	USB/RS-232 Converter for 900 Touch Control / Ti-Touch

Caution: No rack or sample beakers are included! These items depend on the analysis, number of samples, and sample quantity.

Note: Instead of two 930 systems, one 2.940.2500 can also be used.

Optional accessories: (need to be ordered separately)

IC		
6.2832.000		MSM rotor A
6.2842.020		Adapter Vario to MSM and MSM-LC
6.10xx.xxx		Anion column
6.10xx.xxx		Anion Guard column
6.10xx.xxx		Cation column
6.10xx.xxx		Cation Guard column
6.05330.110		IC equipment: Inline Ultrafiltration 2 - push mode

*Recommended set for the combination with Inline Dilution (MIDT).

OMNIS sample racks

6.02041.040	OMNIS sample rack 25 x 75 mL
6.02041.030	OMNIS sample rack 16 x 120 mL
6.02041.050	OMNIS sample rack 9 x 150 mL
6.02041.010	OMNIS sample rack 9 x 250 mL

Sample beakers

6.01402.000	Sample beakers, clear glass, 75 mL, 30 pieces (for 6.02041.040)
6.01400.300	Sample beakers, clear glass, 120 mL, 20 pieces (for 6.02041.030)
6.01400.200	Sample beakers, plastic (PP), 120 mL, 20 pieces (for 6.02041.030)
6.01400.000	Sample beakers, clear glass, 250 mL, 10 pieces (for 6.02041.010)
6.01400.100	Sample beakers, plastic (PP), 250 mL, 10 pieces (for 6.02041.010)
-	150 mL beaker (tall shape, without spout) *external supplier

Beaker adapter

6.02041.040	OMNIS sample rack 25 x 75 mL
6.02041.030	OMNIS sample rack 16 x 120 mL
6.02041.050	OMNIS sample rack 9 x 150 mL

Titration head

6.01403.030	Titration head 3xNS14 / 4x6.4 mm (P&P)
6.01403.040	Titration head 2xNS14 (P&P)
6.01403.000	Titration head 6xNS14 / 3xNS9 (P&P)
6.01403.070	Titration head 3xNS14 / 4x6.4 mm; 4x dosing tips

Stirring propeller

6.01900.020	Stirring propeller 13 mm ETFE
6.01900.030	Stirring propeller 20 mm ETFE
6.01900.010	Stirring propeller 30 mm ETFE

Gripper fingers

6.02601.040	Gripper fingers 28 - 48 mm
6.02601.010	Gripper fingers 43 - 65 mm
6.02601.030	Gripper fingers 48 - 64 mm
6.02601.020	Gripper fingers 50 - 72 mm
6.05700.000	Consumable Kit OMNIS Gripper

Sample Robot

6.05800.540	Upgrade Pick&Place WSM
6.05800.560	Upgrade Stirrer WSM
6.05800.570	Upgrade Pump Module WSM

6.05800.630	Conversion kit M/L P&P to WSM
6.05800.600	Upgrade OMNIS Sample Robot S-M
6.05800.610	Upgrade OMNIS Sample Robot S-L
6.05800.620	Upgrade OMNIS Sample Robot M-L
6.05700.010	Consumable Kit OMNIS Pump Module (2-channel)
6.05700.250	Consumable Kit OMNIS Gripper for 6.02601.030
6.01804.460	Drain channel kit for OMNIS Main Module M/L

Discover

6.02007.010	Lid tray for OMNIS Sample Robot S WSM
6.05800.070	Lid tray upgrade for OMNIS Sample Robot S WSM to M/L
6.02007.020	Lid trays for OMNIS Sample Robot M/L
6.02710.030	Dis-Cover lid for OMNIS 75 mL sample beaker, 25 pieces
6.02710.040	Dis-Cover lid for OMNIS 120 mL sample beaker, 16 pieces
6.02710.050	Dis-Cover lid for OMNIS 250 mL sample beaker, 9 pieces

Inline Eluent Preparation

6.206.1120	System Connector
2.941.0010	941 Eluent Production Module
2.800.0010	800 Dosino
6.5330.090	IC Equipment: Additional Eluent on the Eluent Production Module
6.2769.110	Sensor EMPTY for 2 L bottles

Titration Equipment

6.2324.010	Conductivity standard (100 µS/cm)
6.2301.060	Conductivity standard (12.88 mS)
6.2307.100/110/120	Buffer solutions 500 mL, pH 4 / 7 / 9
6.2325.000	pHit kit
6.1608.030	Glass bottle GL45 1L (round)

1. Installation

The following is a detailed description of the TitrIC flex II installation.

A flow chart of the final setup is displayed on the last page.

We strongly recommend that the individual steps are carried out in the order given below!

1.1. Software

All programs must first be shut down. Ensure that no Metrohm instrument is connected to the PC. First, install MagIC Net and then OMNIS to prevent problems during the installation process. All the standard directories proposed by the program should be accepted.

From now on, every new Metrohm instrument connected to the PC will be recognized automatically and its driver will be installed. If the device is recognized by the software. Then a window will pop up in MagIC Net asking if you would like to store this device in your configuration. The names will be checked later in this installation instruction document, however it is recommended to use the proposed instrument names.

As soon as both software used in the setup are installed, connect the RS-232 cable with the USB/RS-232 converters to two USB plugs. It is recommended to always use two USB hubs at the PC, and not those included on the Metrohm instruments, as these ports are faster and more reliable. Please wait until the driver for the converters has been installed. In the device manager, check the port numbers which are occupied by the two adapters (see Figure 2). You will need to use these numbers later.

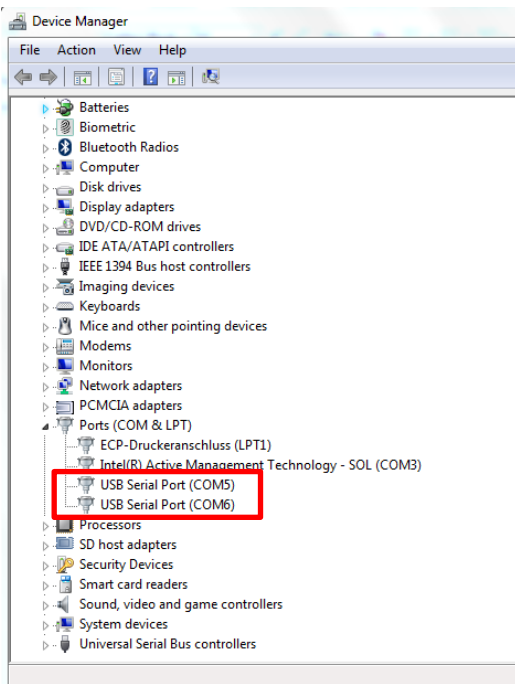

Figure 2: Device manager, with used COM-Ports

1.2. Accessory Kit: Vario/Flex Basic (6.5000.000)

Place the 930 Compact IC Flex Oven/SeS/PP/Deg (2.930.2560) to the right of the Sample Robot, and the 930 IC Compact Flex Oven/Deg (2.930.2160) next to the anion IC. The IC instruments can already be installed using the two Accessory Kits Vario/Flex Basic.

Place the detector blocks in the instruments and connect the detector cables to the back of the instruments. Remove the transport locking screws, connect the leak sensor cables, and connect the drainage tubing.

Connecting the drainage tubing

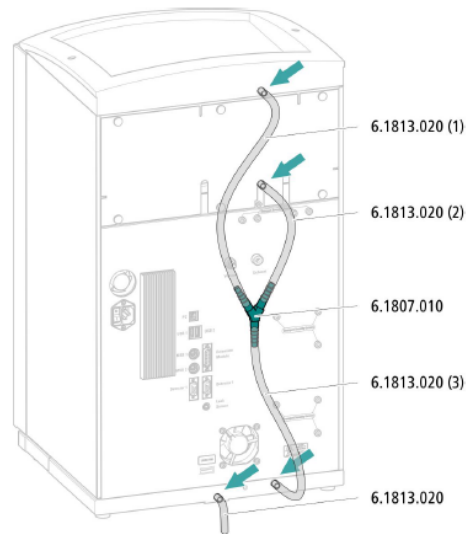

- 1 Cut a piece of silicone tubing into three pieces using scissors: 2 x approx. 40 cm and 1 x 20 cm
- 2 Attach one end of the 40 cm long piece to the drainage tubing connection on the bottle holder.
- 3 Attach one end of the 20 cm long piece to the drainage tubing connection on the detector chamber.
- 4 Attach each of the loose ends of both pieces of silicone tubing to one end of the Y connector.
- 5 Attach one end of the second 40 cm long piece to the third end of the Y connector.
Attach the loose end to the right-side drainage tubing connection on the base tray.
- 6 Attach one end of the second piece of silicone tubing to the left-side drainage tubing connection on the base tray.

Figure 3: Correct drainage tubing installation

Next, mount the holder for Dosinos (6.2057.210, included in the IC equipment: Dosino regeneration) on the IC by removing the bottle holder on top of the instrument, placing the Dosino holder on the side of the IC, and remounting the bottle holder on top. It is recommended to place this on the

left side of the anion instrument, as it can then also be used for the titration liquid handling Dosino, and thus minimizing tubing lengths.

To continue, set up the waste collectors by assembling the caps and screwing them onto the vessels. Hang the waste collectors in their holders. Make sure you have an unobstructed view of the waste collectors so you can later observe the droplets coming out of the capillaries connected to them. Attach a waste tube to each vessel and lead it to the waste canister. Long tubes must be shortened, as it is important to have a large height difference for the liquid to drain properly.

The power cables and the USB cables for connection of the ICs to the PC (6.2151.020) are plugged into the rear of the two Compact IC Flex systems. Do not switch on the instruments yet.

1.3. Accessory Kit: Vario/Flex ONE (6.5000.010)

In the boxes with the Accessory Kit: Vario/Flex ONE, you will find all the accessories for setting up the eluent bottles. Lead the aspiration tube for the Eluent through the M8 thread/screw, the O-ring, and the eluent cap, as shown in Figure 4.

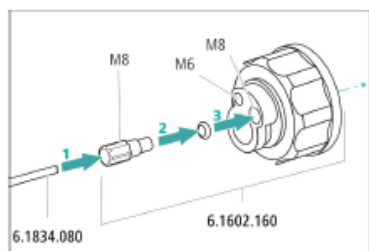

Figure 4: Eluent cap assembly

Then fix the white weight (6.2744.210), the adapter (6.2744.210), and the aspiration filter (6.2821.090) on the eluent aspiration tubes (Figure 5), all the while being careful not to touch the filters and their connections with bare hands in order to avoid contamination.

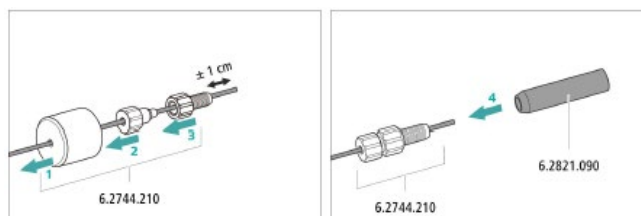

Figure 5: Eluent aspiration filter installation

Finally, secure the filled adsorber tube to the eluent cap. Refer to the 930 Compact IC Flex manual for a detailed description.

1.4. IC Equipment: Dosino Regeneration (6.5330.190)

The Dosino is placed on the 807 Dosing Unit 2 mL and the combined module is installed on the holder for Dosinos using the thread adapter (6.1618.020). The Dosino is plugged in to MSB1 on the IC (make sure the IC is turned off for this step).

At this time, prepare the regeneration solution bottle. For this, remove all accessories from the FEP aspiration tubing (6.1829.020) and lead it from the top through the M6 hole of the eluent bottle cap. Cut the tubing to the appropriate depth of the bottle you are using for your regeneration solution with the help of a capillary cutter. Fill this bottle with a solution of 500 mmol/L H₂SO₄.

A higher concentration of sulfuric acid is needed for the Dosino Regeneration than for the traditional regeneration with the peristaltic pump. This is due to the fluoride peak, which increases in width and loses height over time if a lower concentration regeneration solution is used. This will result in a decrease of sensitivity.

Afterwards, close the M8 hole with the M8 stopper in order to avoid any direct air contact. Fill the adsorber tube delivered with the 807 Dosing Unit (6.1580.120) with some cotton and adsorber material. The adsorber is then placed in the SGJ opening of the bottle cap using the adapter (6.1624.000).

Next, connect the FEP tubing (6.1805.120) to port 2 of the 807 Dosing Unit, and to the M6 hole of the eluent bottle cap for the regeneration solution.



Figure 6: Dosino connections for regeneration

In the last step, the 807 Dosing Unit needs to be connected to the MSM inlet capillary (labeled with regenerant). For this, tighten the M5 thread / UNF 10/32 adapter (6.27744.080) on port 1 of the 807 Dosing Unit. Lead the MSM capillary regenerant through one of the ducts for capillaries on the IC (between base tray and instrument, or between the bottle holder and instrument) in the shortest way possible to reach the Dosino. For cleaning purposes, an inline filter (6.2821.120) must be installed between the Dosino and MSM (be careful to exchange the filter on a regular basis). For this,

cut the regenerant capillary with a capillary cutter to an appropriate length. Install this PTFE capillary between the 807 Dosing Unit port 1 and the inline filter with two PEEK pressure screws. The other end of the inline filter is attached to the original MSM capillary regenerant as shown in Figure 7.

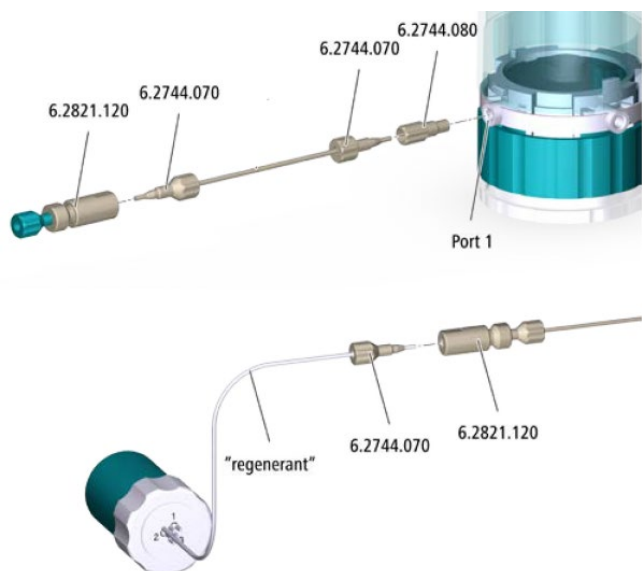

Figure 7: Connections for MSM regeneration

1.5. IC equipment: Inline Ultrafiltration 2 - pull mode (6.05330.010)

An ultrafiltration cell is mounted in between the sample pick-up (on the Sample Robot) and IC system. For this, place the Ultrafiltration cell 2 holder (6.02057.120), which is a separate item not included in the IC equipment: Inline Ultrafiltration 2 - pull mode (6.05330.010), into the IC next to the Detector. The filter membrane is first hydrated in ultrapure water (UPW) for preconditioning. After inserting the hydrated filter membrane, screw the cell together tightly. For the following installation instructions, please make sure only to use PVDF pressure screws (6.2744.000) on the cell, as otherwise the material of the cell will break under the pressure. Capillary connections are shown in Figure 8. The flow must be higher on the sample side than at the filtrate side. That is why it is important to use a wider pump tubing (yellow/yellow) on the sample side, and a narrower pump tubing (orange/white) and the shortest possible 0.5 mm ID capillaries on the filtrate side. For detailed instructions, please refer to the Ultrafiltration Cell 2 manual.

The push set (6.05330.110) is recommended for the combination with Inline Dilution (MIDT) in push/pull mode.

1.6. Setup and connection of the two ICs

Capillaries of the anion and cation IC are to be connected according to the following list and Figure 8, using the accessory kit: Vario/Flex SeS (6.5000.020) and further accessories in the delivery:

1. Connection to the anion eluent bottle
2. Capillary to anion column inlet – 0.25 mm ID
3. Analytical anion column, the UNF 10/32 coupling (6.2744.040) is installed instead of the column to rinse the system with eluent. After rinsing, the column is installed
4. MSM inlet capillary – labeled with *in*
5. MSM outlet capillary – labeled with *out* – can be connected to the MCS using the PEEK pressure screw long (6.2744.090) or directly to the detector using a coupling (6.2744.040)
6. MCS (Metrohm CO₂ Suppressor)
7. MCS air aspiration capillary – connected to the CO₂-adsorber cartridge (6.2837.100) with the luer adapter (6.2744.120)
8. Anion detector inlet capillary connected to the MCS *Out* using the PEEK pressure screw long (6.2744.090)
9. Anion detector outlet capillary connected to the MSM inlet capillary – labeled with *rinsing solution*
10. PEEK pressure screws (6.2744.070) and coupling (6.2744.040)
11. Waste MSM rinsing solution outlet capillary – labeled with *waste rinse* – to be connected to the waste collector
12. MSM regeneration inlet capillary – labeled with *regenerant*, coming from the 800 Dosino (chapter: 1.6 IC Equipment: Dosino Regeneration (6.5330.190)
13. MSM regeneration solution outlet capillary – labeled with *waste reg.* – to be connected to the waste collector
14. Connection to the cation eluent bottle
15. Capillary to cation column inlet – 0.25 mm ID
16. Analytical cation column, the UNF 10/32 coupling (6.2744.040) is installed instead of the column to rinse the system with eluent. After rinsing, the column is installed.
17. Cation detector inlet capillary
18. Cation detector outlet connected to the waste collector
19. Sample aspiration capillary – PEEK, 0.5 mm ID – is connected to the Micro capillary (6.2744.080) at the Sample Robot on Workstation 2 using the adapter M6/UNF (6.2744.080). The other end is connected to the ultrafiltration cell.

20. Ultrafiltration cell - PVDF pressure screw (6.2744.000) for connecting the capillaries to the ultrafiltration cell
21. PTFE capillary (6.1803.100) for conveying the sample from the ultrafiltration cell to peristaltic pump (0.5 mm ID)
22. PEEK pressure screw (6.2744.070) and Coupling olive (6.2744.030)
23. Peristaltic pump tubing (6.1826.390) with yellow/yellow stoppers for conveying the sample
24. Coupling olive/UNF (6.2744.030) and PEEK pressure screw (6.2744.070)
25. PTFE capillary (6.1803.040) 0.5 mm ID for conveying the sample from the peristaltic pump to the waste collector
26. PTFE capillary (6.1803.040) for conveying the filtrate from the ultrafiltration cell to the injection valve for anion analysis in the IC instrument
27. Injection valve connection capillary – PTFE, 0.5 mm ID – connects the anion injection valve with the cation injection valve – use PEEK pressure screws (6.2744.014)
28. PTFE capillary (6.1803.050) for conveying the filtrate from the cation injection valve to the peristaltic pump
29. PEEK pressure screw (6.2744.070) and Coupling olive (6.2744.030)
30. Peristaltic pump tubing (6.1826.330) with orange-white stoppers for conveying the filtrate
31. Coupling olive/UNF (6.2744.030) and PEEK pressure screw (6.2744.070)
32. Sample outlet capillary – PTFE capillary (6.1803.040) for conveying the filtrate from the peristaltic pump to the waste collector

Make sure that all outlet capillaries (11, 13, 18, 25, 32) are placed inside of the waste collector.

For further installation instructions for the ion chromatographs, please consult the following Application Bulletins: Installation Instructions for Profic Vario 1 Anion (800105003EN) and Installation Instructions for Profic Vario 1 Cation (800105004EN).

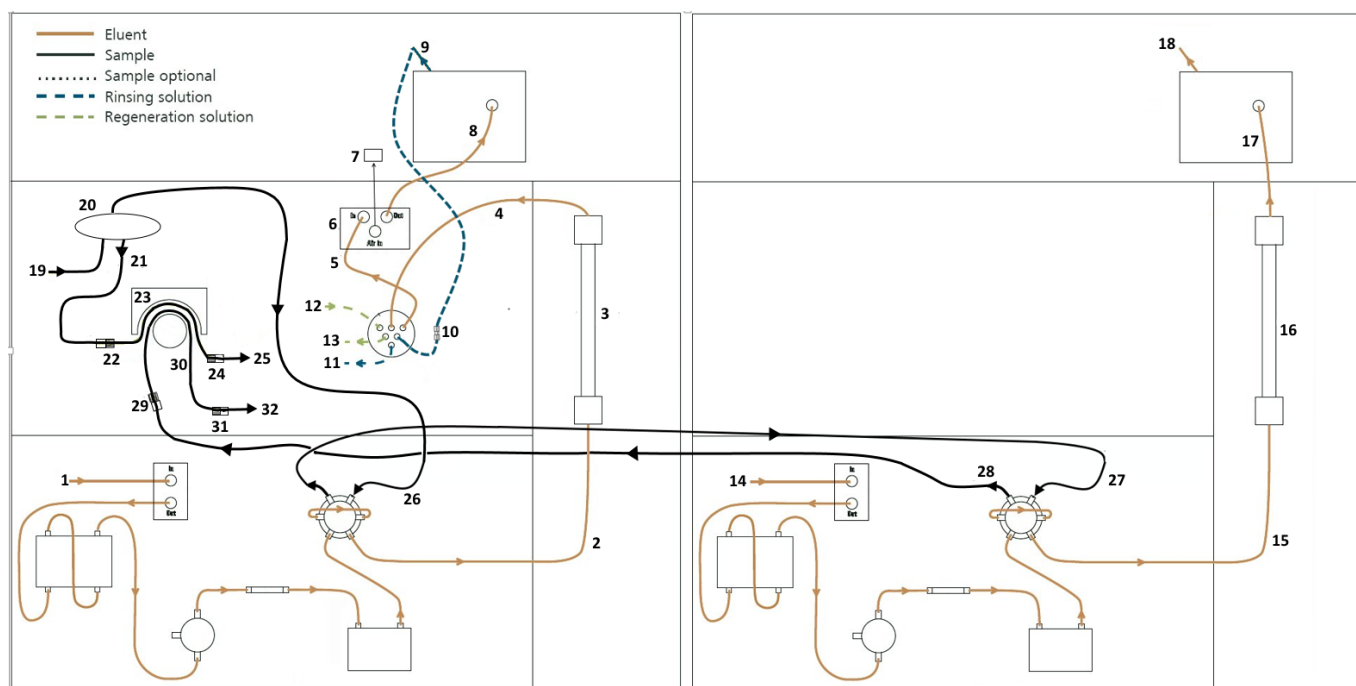

Figure 8: Capillary connections in the ICs

1.7. Sample Robot S WSM

The Sample Robot is placed on the left-hand side of the IC system and on the right-hand side of the Titrator and Dosing Module (i.e., in between the two main analytical devices for TitrIC flex).



Figure 9: Complete TitrIC flex II setup

The two canisters delivered with the Sample Robot are placed on the floor in the vicinity of the TitrIC flex system. One of the two 10 L canisters will be used as a waste container and the second one as a reservoir of UPW used for rinsing the sample beaker and the electrodes.

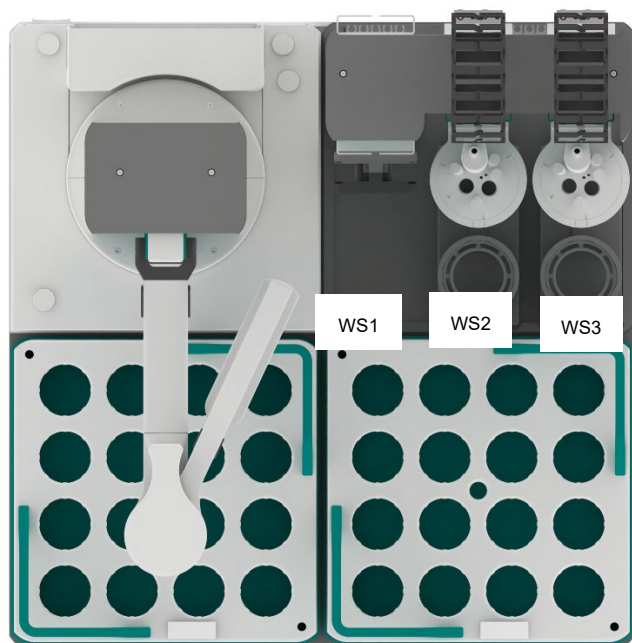

Figure 10: Sample Robot S WSM as viewed from above

WS = Workstation
RP = Rack position

1.7.1. Rear of the Sample Robot S

The installation of the Sample Robot S WSM will start at the back side of the device. Please check with Figure 11 for the correct installation.

In general, pumps 1 and 2 are connected to Workstation 2. Pumps 3 and 4 are connected to Workstation 3. Pumps 1 and 3 are used for rinsing, and pumps 2 and 4 are used for the purpose of aspiration.

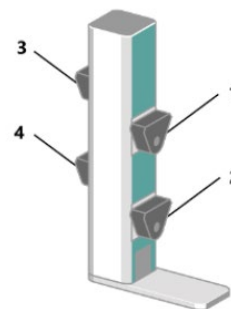
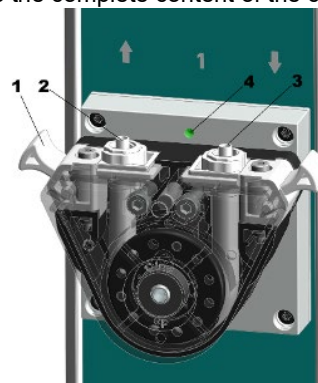

Figure 11: Pump module

1. Make sure that one 2.5 m PTFE tubing with Luer (6.01805.120) is connected to the outlet of the peristaltic pump 2, and another 2.5 m PTFE tubing with Luer (6.01805.120) is connected to the inlet (number 3 in Figure 12) of the peristaltic pump 1, in order to transfer the liquid to the waste canister.
2. Next, one 2.5 m PTFE tubing with Luer (6.01805.120) connects the UPW container to the inlet (number 3 in Figure 12) of the peristaltic pump 1, and another 2.5 m PTFE tubing to pump 3. Make sure the tubing reaches the bottom easily in order to use the complete content of the canister.



- | | |
|---------------|----------|
| 1 Press clamp | 2 Outlet |
| 3 Inlet | 4 LED |

Figure 12: Pump connection

3. Plug the three 65.5 cm rinsing tubings (number 1 in Figure 13) in the M6 holes of the distributor (number 3 in Figure 13). On the other end of these rinsing tubes, tighten the spray nozzles (6.2740.020). They will be placed into their respective holes later on during the installation.
4. The remaining M8 hole of the distributor serves to connect the aspiration tubing (number 2 in Figure 13). On the other side of the tubing, the appropriate aspiration tip is connected. This tip will also be placed in its correct hole later on during this installation.

5. Make sure to connect the 60 cm PTFE tubing with Luer 60 (number 4 in Figure 13) to the rinsing pump outlet (pump 1 or pump 3). The 80 cm PTFE tubing with Luer (number 5 in Figure 13) leads to the aspiration pump inlet (pump 2 or pump 4).

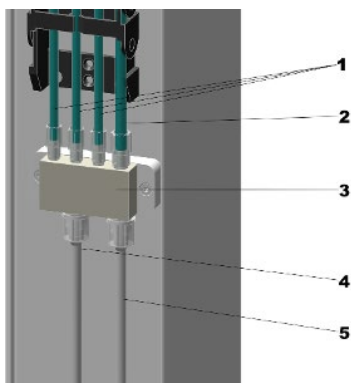

Figure 13: Tubing connection at distributor

6. Plug the drainage tubing (number 2 in Figure 14: *Connecting and placing the drainage tubing*) in the tubing adapter (number 1 in Figure 14) for spilled liquids on the rear of the modules. Lead the tubings to the waste canister.

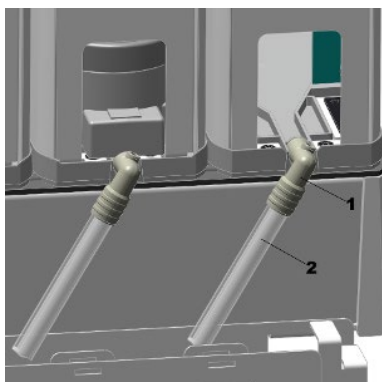

Figure 14: Connecting and placing the drainage tubing

1.7.2. Front of the Sample Robot S WSM

Place two 120 mL sample racks, or any other purchased rack, properly on the rack base.

Note: If using other racks, keep in mind to adapt the titration head size as well as the beaker adapter.

1. Insert the titration heads in the corresponding holders and mount the safety shield from the bottom into the titration head holder.

Table 1: Titration heads if using 120 mL Racks

Titration head	
WS2	120 mL (6.01403.030)
WS3	150 mL (6.01403.070)

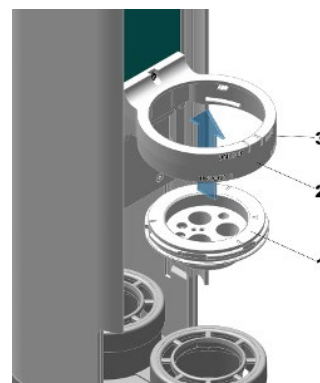

Figure 15: Insert titration head

2. Insert the beaker adapter (number 3 in Figure 16) from above into the slide:

Table 2: Beaker adapter if using 120 mL racks

	front position	back position
WS2	120 mL	120 mL (6.01404.030)
WS3	120 mL	150 mL (6.01404.050)

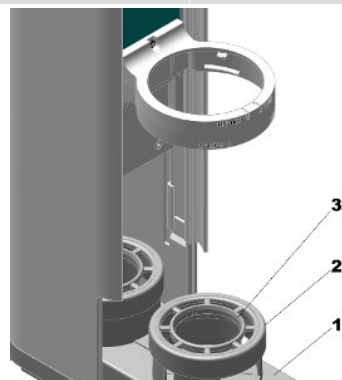

Figure 16: Insert beaker adapter

3. Insert the rod stirrer from above into the position intended for this purpose (number 2 in Figure 20). Place the corresponding stirring propeller from below onto the rod stirrer coupling and connect the cable of the rod stirrer to the MDL socket of the main module.

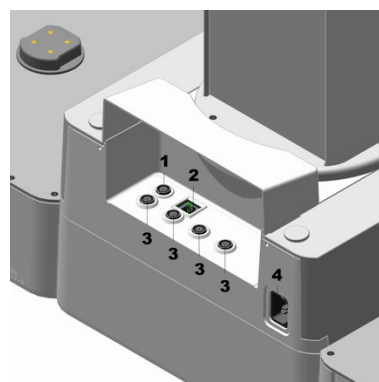

Figure 17: MDL socket of the Sample Robot S WSM

Make sure the stirring propeller does not touch the bottom of the vessel, but extends to approximately the lower third of the container.

For thorough rinsing of the titration vessel, the rinsing nozzles need to be distributed around the vessel lid as shown in Figure 18.



Figure 18: Installation of rinsing nozzles

1.8. Titration head WS2 (6.01403.030)

The openings of the titration head are filled as follows:

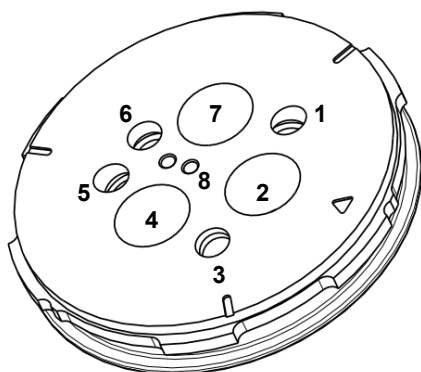

Figure 19: Distribution of different tubing and electrodes on the titration head WS2 for 120 mL beaker

1. Rinsing nozzle (6.2740.020) connected to the FEP tubing of the distributor at the Sample Robot
2. Tip (6.1543.060) connected to port 2 of the 50 mL 807 Dosing Unit (using the 6.1446.030 Ball stopper) for sample aspiration
3. Rinsing nozzle (6.2740.020) connected to the FEP tubing of the distributor at the Sample Robot
4. Micro capillary (6.1543.040) with M6 adapter for IC (6.2744.080) is inserted into the opening 4 (using the 6.1446.030 Ball stopper)
5. Rinsing nozzle (6.2740.020) connected to the FEP tubing of the distributor at the 815 Sample Robot
6. Tip (6.1543.060) used as an aspiration tip, which is connected to the distributor at the Sample Robot (using the 6.1808.040 adapter M6/M8). Make sure it touches the bottom of the vessel but does not interfere with the stirrer propeller.

7. Conductivity measuring cell (6.0915.100)
8. Two retracted dosing tips are not used and can be removed.

1.9. Titration head WS3 (6.01403.070)

The openings of the titration head are filled as follows:

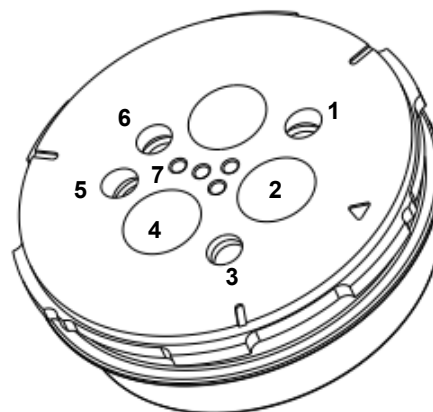

Figure 20: Distribution of different tubing and electrodes on the titration head WS3 for 150 mL beaker

1. Rinsing nozzle (6.2740.020) connected to the FEP tubing of the distributor at the Sample Robot
2. Rod stirrer
3. Rinsing nozzle (6.2740.020) connected to the FEP tubing of the distributor at the Sample Robot
4. dAquatrode (6.00202.300)
5. Rinsing nozzle (6.2740.020) connected to the FEP tubing of the distributor at the Sample Robot
6. PTFE aspiration tip, which is also connected to the distributor at the Sample Robot, is inserted into opening no. 6. Make sure it touches the bottom of the vessel, but does not interfere with the stirrer propeller.
7. Retracted dosing tips, respective tubing will be mounted later during the installation

1.10. 800 Dosino & 50 mL 807 Dosing Unit

For sample transfer of the titration part, a Dosino with a 807 Dosing Unit of 50 mL is used. Before connecting the 807 Dosing Unit ports, mount the 807 Dosing Unit with the Dosino onto the Dosino holder on the IC. For this, place the 807 Dosing Unit over the free opening in the Dosino holder, and fix it from the bottom with the thread adapter (6.1618.020). Then, place the Dosino on top and lock the 807 Dosing Unit to its motor. The Dosino must be connected to an MSB port of the 856 Conductometer (2.856.0010).

The connections on the 807 Dosing Unit follow. Please install mainly the ends at the DU—the other end will be connected to the correct position in the following chapters.

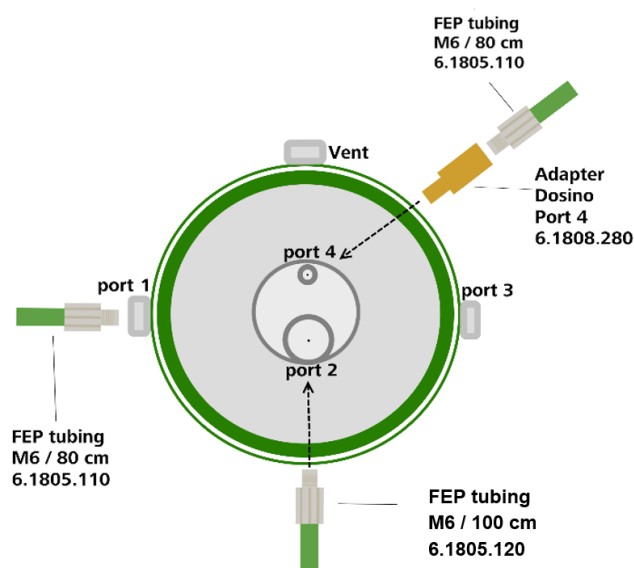

Figure 21: Connections to the LH 807 Dosing Unit

- **Port 1** is used for transferring the sample to the titration beaker at Workstation 3 using FEP-tubing 6.1805.110 (80 cm, supplied by the Sample Robot) connected to one of the retracted dosing tips on the titration head (6.01403.070).
- **Port 2** is used for aspirating the sample from Workstation 2 using FEP-tubing 6.1805.120 (100 cm, again supplied by the Sample Robot).
- **Port 4** requires a coupling between luer and M6 (6.1808.280). This port is used for emptying the 807 Dosing Unit into the waste canister. Here the FEP-tubing (6.1805.030) with 80 cm length is used.

1.11. Conductivity (6.0915.100)

It is essential to install the conductivity measuring cell and the Aquatrode separately from each other, as it has been observed that the electrolyte outflow from the Aquatrode can falsify the conductivity values.

1.12. Titrator

The Titrator (2.1001.0310) is best placed to the left side of the Sample Robot S. This guarantees a compact setup.

The Titrator is the central instrument of an OMNIS titration system; it is connected to the Ethernet network and to the power grid. The Dosing Module is directly connected to the Titrator via MDL cable. Insert the digital measuring module (6.02100.010) into the Titrator.

1.12.1. 20 mL Cylinder Unit (6.1580.220)

The 20 mL Cylinder Unit is mounted on the Titrator and will be used to transport 0.1 mol/L HCl for the adjustment of the pH.

The 1 L bottle is placed on the rear side of the Titrator with a bottle cap screwed on top. The Liquid adapter is connected to the module and locked with the bottle cap.

A 40 cm long FEP tubing (6.1805.100, supplied with the Cylinder Unit) connects Port 2 of the Cylinder Unit to the Liquid Adapter.

For dosing purposes, the 150 cm dosing tube connects Port 1 of the Cylinder Unit to a retracted dosing tip on the titration head W3.

1.12.2. dAquatrode plus with Pt 1000 (6.00202.300)

The dAquatrode is inserted into opening number 4 of the titration head at W3. The electrode cable is fixed on top and plugged into the measuring module 1 on the inside of the Titrator. The pH electrode must be regularly filled up with an electrolyte solution (6.2308.020) and kept in the storage solution (6.2323.000) when not used for a period of time.

Make sure the electrode is well positioned in the titration head so the diaphragm is covered with liquid when 100 mL of liquid is held in the 150 mL sample beaker. Also, it should not touch the Rod stirrer or any other object.

1.13. 856 Conductometer (2.856.0010)

The 856 Conductometer is placed directly to the left of the Titrator and is connected to a USB port of the PC with a controller cable (6.2151.000). The power cable is then installed and connected to a power supply.

1.13.1. 5-ring conductivity measuring cell (6.0915.100)

The conductivity measuring cell cable (6.0915.100) is connected to the "Cond. Cell" socket in the rear of the 856 Conductometer.

Before measurement and after longer downtimes it is recommended to carry out the calibration of the cell constant. For further information, consult the Installation Instructions of the 856 Conductometer.

2. Software

The IC instruments and the 856 Conductometer are connected to the computer via controller cables before their power is connected. The drivers of the instruments are automatically installed.

The OMNIS devices are connected via Ethernet to the router and to the PC. *Do not connect the Ethernet cable of the Sample Robot directly to the PC!*

The communication, e.g., result and command transfer between MagIC Net and OMNIS, is done via RS-232. MagIC Net is the master in this setup. To establish the communication, follow these steps:

Make sure that both MagIC Net and OMNIS are closed. If the PC has two built-in RS-232 ports, then connect the RS-232 cable (6.2134.040) directly between these two ports. If the PC does not have the built-in RS-232 ports, then connect two USB/RS-232 Converters (6.2148.050) to the two USB ports. You can alternatively use the USB hubs of the IC instrument, but it is recommended to use the USB hubs of the PC because they are more powerful. Then connect the two converters using the RS-232 cable (6.2134.040). In the Device Manager of your Windows operating system, check which two ports are used.

2.1. MagIC Net

2.1.1. Devices

When MagIC Net is started, connected USB devices are automatically recognized. After confirmation of the pop-up windows, the devices and columns are stored in the configuration. It is recommended to keep the proposed names, and to call the suppression solution 807 Dosing Unit "Suppressor Dosino". The column can be freely named.

The devices are predefined as «930 Compact IC Flex 1» and «930 Compact IC Flex 2» Name them accordingly, just in case other names appear in your configuration (e.g., due to changed settings on your computer).

Add and define the eluents in the configuration window and register the MSM rotor with its serial number.

In the devices window, select 'Edit/New/Miscellaneous' and choose the RS-232 device. Keep the proposed Device name and enter a random serial number. Go to the RS-232 subsection and choose one of the ports from the device manager. Leave all other settings unchanged, as they are preconfigured. Click on 'Connect' and confirm with <Ok>.

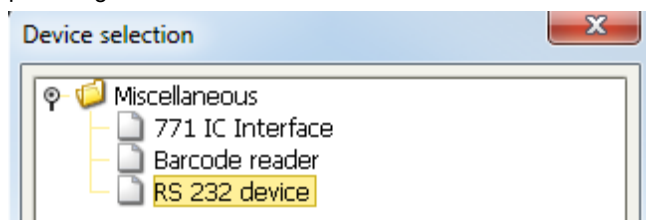

Figure 22: Adding the RS-232 device to MagIC Net

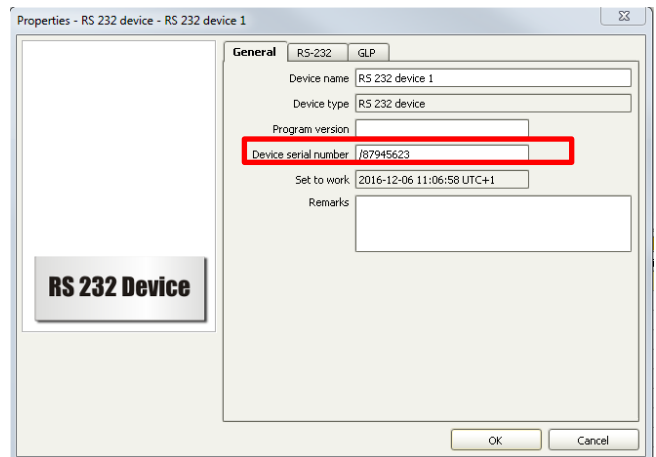

Figure 23: RS-232 device with serial number

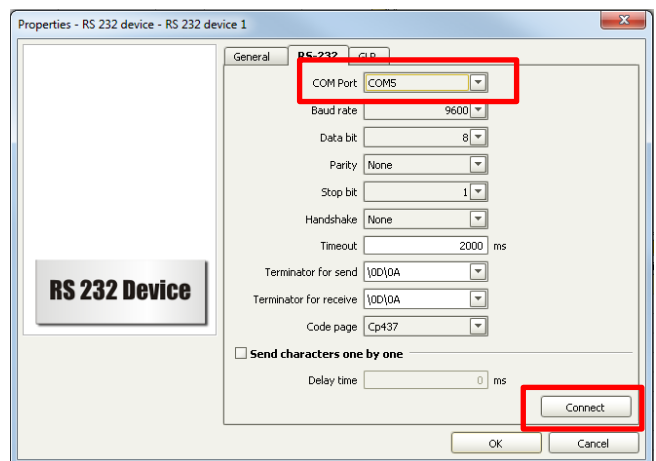

Figure 24: Connecting the RS-232 device

Devices				
	Device name	Device type	Device serial n...	Status
1	RS 232 device 1	RS 232 device	7854963	ok

Figure 25: Added RS-232 device

2.1.2. Modifications to the method

The following method (*.imet file) is provided for **MagIC Net**:
TitriC flex 2: This method is the standard method. Depending on the input from **Info 1**, different subprograms will be carried out.

This method is used in combination with the **TitriC flex 2** or **TitriC flex 2 Dis-cover** OP (Operating Procedure) in **OMNIS**.

Import: Click on **Method** at the left, then select under **File / Method manager... / Edit / Import...** Import the method TitriC flex 2 from the MagIC Net CD. You will find the methods in the folder on the CD: examples/methods/TitriC flex.

You can also find the templates in the **Metrohm Knowledge Base** under the following link: guide.metrohm.com (Internet access is required). Search for the templates using the keyword "TitriC" and download them from there. Unpack the ZIP file using a suitable ZIP tool (e.g., WinZip).

Important note!

Alterations of these methods should only be carried out by a user at the administrator level and who is thoroughly familiar with MagIC Net.

In the method window, under **Evaluation**, enter the ions and the concentrations of the required standards. The preferred database can be chosen under *Evaluation* → *Results* → *Database* if a different database than «MagIC Net» is used.

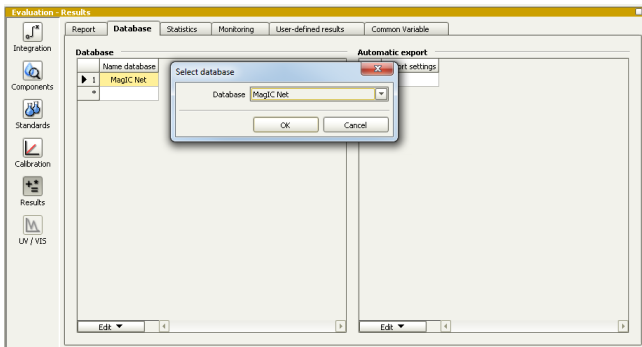

Figure 26: Database selection (MagIC Net)

In the method properties, all fixed values can be adapted to the individual setup.

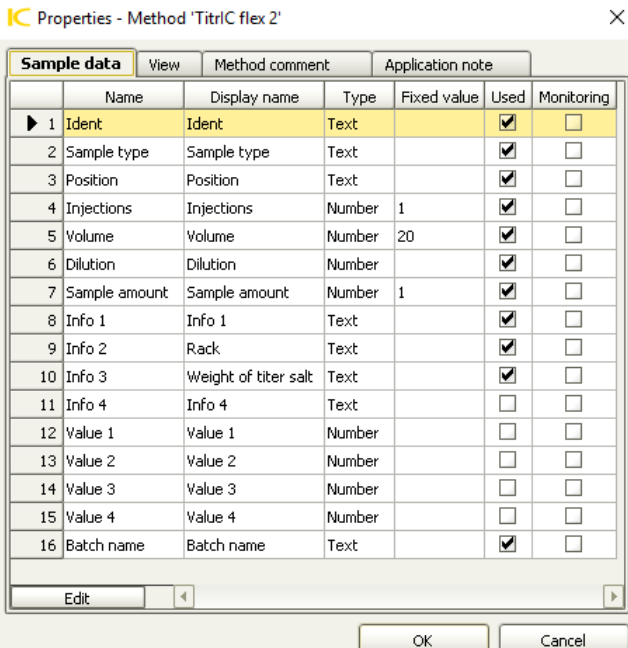

Figure 27: Properties of the method (MagIC Net)

2.1.3. Workplace setup

In order to use the full flexibility of the TitrIC flex 2 method, add some text templates in the workplace of MagIC Net. This will result in dropdown options in the determination table and easier handling for the user. Mainly, it will reduce the risk of typing errors.

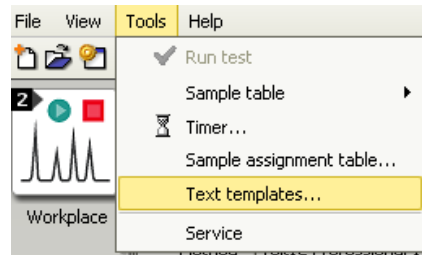

Figure 28: Accessing text templates for Info 1

Create text templates for Info 1 according to Figure 29. Make sure to write the terms *exactly* as shown here, otherwise the method will not work correctly.

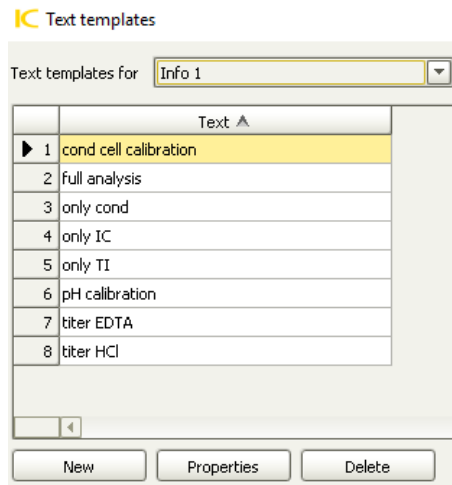

Figure 29: Info 1 text templates

Only cond (Conductivity)

The sample is measured with the conductivity measuring cell on Workstation 2.

(80 mL sample required)

pH calibration

Sequentially, each of the pH standards is transferred to the Workstation 3 and used for calibrating the dAquatrode. The standards must be placed successively on the rack, where the first has to be entered as sample position.

(80 mL of each required)

Cond cell calibration

The appropriate conductivity standard is measured with the conductivity cell on Workstation 2.

(80 mL standard required)

Full analysis

The sample is first flushed through the anion sample loop and then injected onto the analytical column. At the same time, the conductivity of the sample is measured on Workstation 2. Following this, exactly 100 mL of the sample is transferred to the titration vessel on Workstation 3. Afterwards, the m- and p- values as well as pH, temperature, and water hardness are determined.

(120 mL sample required)

Only IC (Ion chromatography)

The sample, check standard, or calibration standard is aspirated through the IC sample loop, injected, and then analyzed.

(5 mL solution required)

For calibration and check standards, keep in mind that the cation standard must be injected first, followed by the anion standard. Therefore, place the standards accordingly on the same rack.

For example: Sample Position 1 = cation standard 1

2 = anion standard 1

3 = cation standard 2

4 = anion standard 2

Only TI (Titration)

First, the conductivity of the sample is measured at Workstation 2, then an exact volume of the sample is transferred into the titration beaker on Workstation 3. Afterwards the temperature, pH, acid capacity (p- and m-values), and the hardness are determined sequentially.

(110 mL sample required)

Titer HCl (0.1 mol/L)

Weigh approximately 0.1 g TRIS with an accuracy of 0.1 mg into the sample beaker. Add approximately 60 mL of deionized water and place the beaker on the rack. Enter the exact weight in the window in MagIC Net. The titer of HCl is determined on Workstation 3.

(0.1 g TRIS required)

In the Sample list properties, rename the Info 2 to "Rack" and Info 3 to "Weight titer salt". Also, it is only necessary to display Ident, Sample type, and Position.

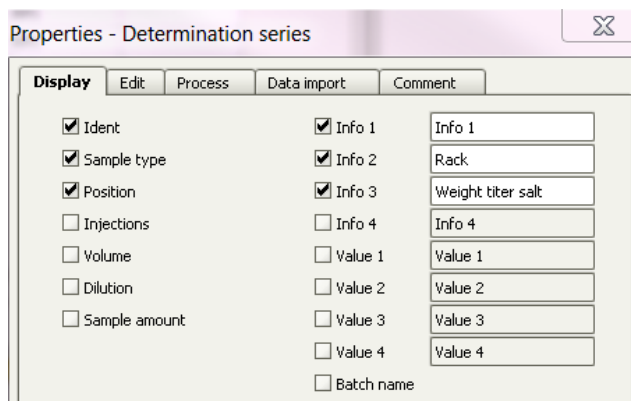

Figure 30: Sample table properties

Enter the sample position, rack, and sample identification into MagIC Net only. Choose the appropriate **sample type** and analysis technique (**Info 1**) in the dropdown menu, and then enter the weight of the salt if carrying out a titer.

	Method	Ident	Sample type	Position	Status	V...	Info 1	Rack	Weight titer salt
1	TitrIC flex 2	Blank UPW	Sample	1	READ...	20	pH calibration	RP2	
2	TitrIC flex 2	Blank UPW	Sample	2	READ...	20	cond cell calibration	RP2	
3	TitrIC flex 2	Blank UPW	Sample	3	READ...	20	titer HCl	RP2	0.1
4	TitrIC flex 2	Blank UPW	Sample	4	READ...	20	titer HCl	RP2	0.1
5	TitrIC flex 2	Blank UPW	Sample	5	READ...	20	titer HCl	RP2	0.1
6	TitrIC flex 2	Blank UPW	Sample	6	READ...	20	only IC	RP2	
7	TitrIC flex 2	Tap water	Sample	7	READ...	20	full analysis	RP2	
8	TitrIC flex 2	Tap water	Sample	8	READ...	20	full analysis	RP2	
9	TitrIC flex 2	Tap water	Sample	9	READ...	20	full analysis	RP2	
10	TitrIC flex 2	Tap water	Sample	10	READ...	20	full analysis	RP2	
11	TitrIC flex 2	Tap water	Sample	11	READ...	20	full analysis	RP2	
12	TitrIC flex 2	Tap water	Sample	12	READ...	20	full analysis	RP2	
13	TitrIC flex 2	Tap water	Check standard 1	13	READ...	20	only IC	RP2	
*									

Figure 31: Example sample table in MagIC Net

2.2. OMNIS

First, switch on the devices mentioned below by pressing the power button for approximately 1 second. Start the OMNIS software, then search under 'Equipment/Instruments' for available instruments in the 'Inventory' and reserve your:

Sample Robot S, Titrator, 856 Conductivity module, and the **RS-232 device** (serial device COM) by dragging each symbol to the central field.

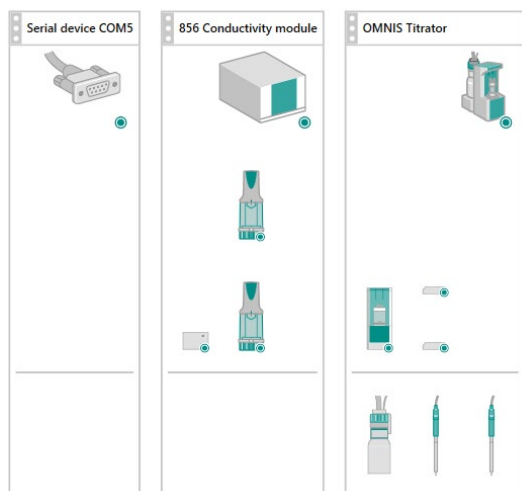

Figure 32: Reserved modules in the OMNIS device area

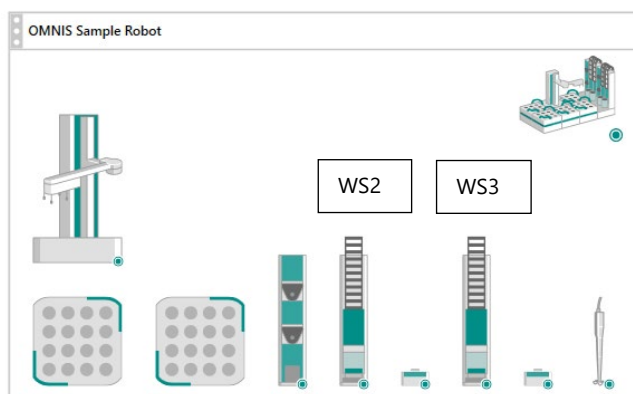

Figure 33: Reserved Sample Robot in the OMNIS device area

The system is displayed in the same order as visible in front of you: from left to right.

2.2.1. Adjustment of the instruments

Rename the functional units as follows in the Instruments area under Properties / Specific data:

- Pick&Place module (left) = W2 Pick&Place module
- Pick&Place module (right) = W3 Pick&Place module
- Rod Stirrer = W3 Rod Stirrer

Check the data in the Properties / Specific data of both Pick&Place modules and adjust the beaker data for the usage with 120 mL beakers (**beaker diameter: 47.3, beaker height: 113.0 mm**). This is to ensure that the gripper will pick up and release the beakers correctly.

2.2.2. Solution/807 Dosing Unit

The solutions to be used must be defined in OMNIS. Make sure the Dosino of the 50 mL 807 Dosing Unit is connected to the MSB port of the 856 Conductivity Module.

Now the names for the 800 Dosino, tubing lengths, and ports must be defined. Click on the respective dosing device and enter the following data under Properties / Specific data:

Table 3: Configuration table of the 807 Dosing Units

800 Dosino	Transfer sample		
	Port	Length	Diameter
Dosing Port 1	Port 3	0 cm	0.0 mm
Dosing Port 2	Port 1	80 cm	2.0 mm
Fill Port	Port 2	100 cm	2.0 mm
Special Port	Port 4	80 cm	2.0 mm

2.2.3. Solution/Cylinder unit OMNIS

The solution to be used must be defined in OMNIS. Make sure the 20 mL Cylinder Unit (0.1 mol/L HCl) is connected to the Titrator.

In the *Instruments* area, click on the respective multi-use bottle cap, and enter the following data under Properties / Specific data:

▲ Component 1

Name

Molecular formula

Molar mass

CAS Registry Number

Concentration

Concentration unit

Figure 34: Specific data for the titrants/solutions

Now the names of the dosing drive, tubing lengths, and ports are defined. Click on the respective Cylinder Unit and enter the following data under Properties / Specific data:

Table 4: Configuration table of the Cylinder Units

Dosing Drive	HCI		
	Port	Length	Diameter
Dosing Port 1	Port 1	150 cm	2.0 mm
Dosing Port 2	Port 3	0 cm	0.0 mm
Fill Port	Port 2	25 cm	2.0 mm
Special Port	Port 4	0 cm	0.0 mm

2.2.4. RS-232

Ensure that the second RS-232 device port was selected, not the same as the one in MagIC Net (e.g., COM 5). In the Equipment work area (under *instruments*), check if the configuration is set correctly for the specific data of the RS-232 (serial device COM). In Properties/General, the Product type is serial device.

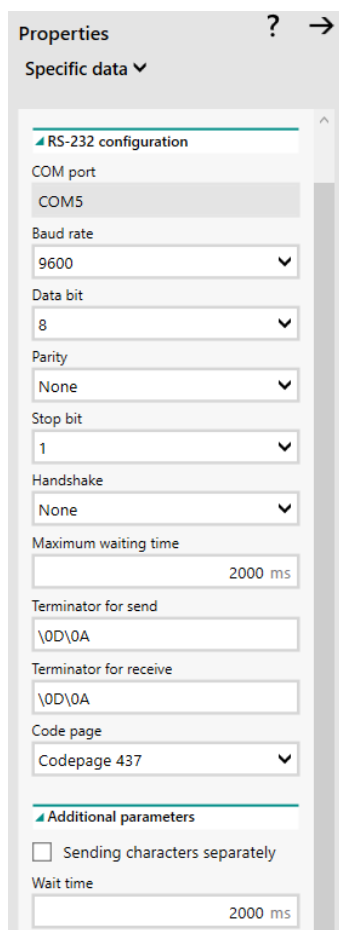

Figure 35: COM port properties

2.2.5. OP template

The following Operating Procedures (OPs) (.opro files) are provided for OMNIS:

TitriC flex 2: This is the standard OP used for OMNIS. Apart from the titration and direct measurements, it handles the calibration of the conductivity cell and pH sensor, as well as the titer determinations of the HCl solutions. All relevant

results are sent to MagIC Net. This method must be used in combination with the **TitriC flex 2** method in MagIC Net.

TitriC flex 2 Dis-cover: In addition to the described OP TitriC flex 2, this OP template provides the Dis-cover function where a Dis-Cover lid covers the vial. The gripper arm removes the lid automatically just prior to the analysis and will return it afterwards.

You will find the templates in the **Metrohm Knowledge Base** with the following link: guide.metrohm.com (internet access is required). Search for the templates using the keyword **"TitriC"** and download them from there. Unpack the ZIP file using a suitable ZIP tool (e.g., WinZip).

2.2.6. Import OP template

Go to 'Process' and import the TitriC flex 2 operating procedure (OP) template and click *open*. The work systems are imported together with the OP.

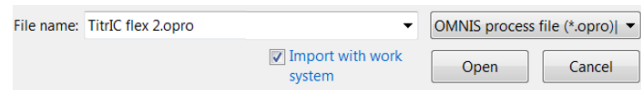

Figure 36: Import OP template

When the TitriC OP template is imported, all related methods are automatically imported as well.

Note: Alterations of these OPs/methods should only be carried out by a user at the administrator level and who is thoroughly familiar with OMNIS.

2.2.7. Work system

The work systems, including default functional units, are already allocated in the example methods. These eight work systems (Figure 37) belong to the TitriC flex 2 OP template:

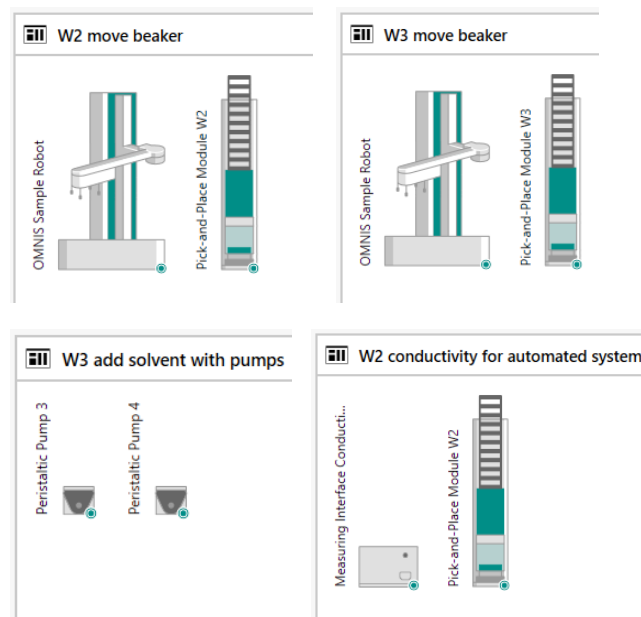

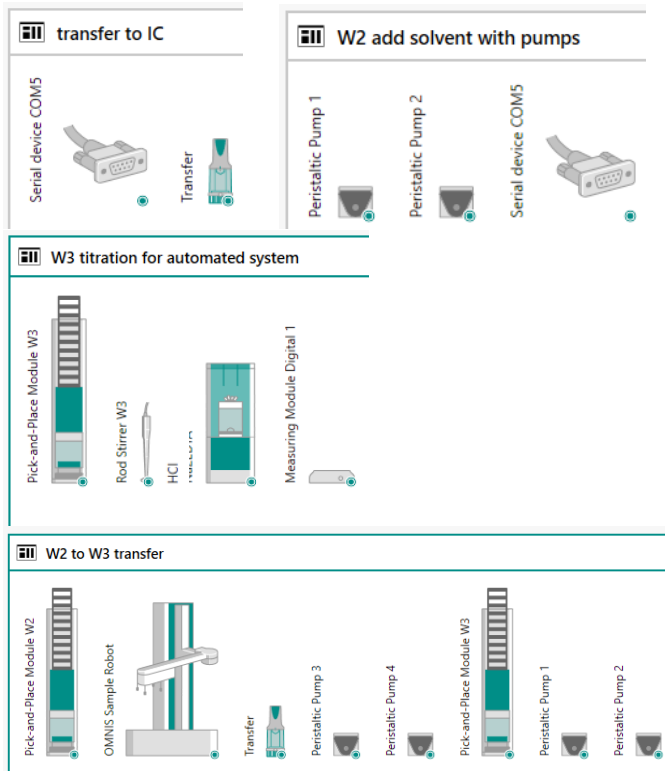

Figure 37: Work systems of the TitrIC flex 2

2.2.8. Replacement of functional units

After importing the OP templates, replace the default functional units with the functional units from your configuration in the work systems via drag and drop (e.g., Pump, Pick&Place, etc.). Afterwards, save the work system.

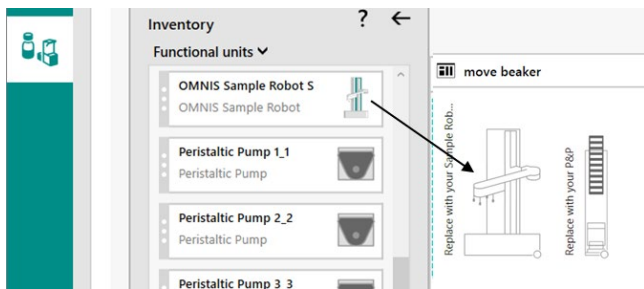

Figure 38: Replacement of the functional units

Note: All functional units have to be replaced with functional units from your system—otherwise the methods will not work. In case a functional unit is not used, delete the corresponding functional unit from the work system. But keep in mind, the removal of a functional unit has an impact on all allocated methods in OMNIS.

2.2.9. Sensors

Check under *Equipment/Sensors* if the following sensors are displayed:

- dAquatrode
- Conductivity sensor (analog electrode)

Analog sensors are added manually under 'Equipment/Sensors/Inventory'. Drag and drop the analog *Conductivity measuring cell* into the sensor window.

In order to ensure compatibility with the methods provided, the created sensor must be named as described below:

'Conductivity measuring cell'

2.2.10. Solutions

In the *Equipment work area* under *Solutions*, click on the **inventory** button and add the *Conductivity standard* via drag and drop into the central field. Edit the conductivity table of your conductivity standard (e.g., 100 $\mu\text{S/cm}$ 6.2324.010) under the *Properties/Conductivity table*.

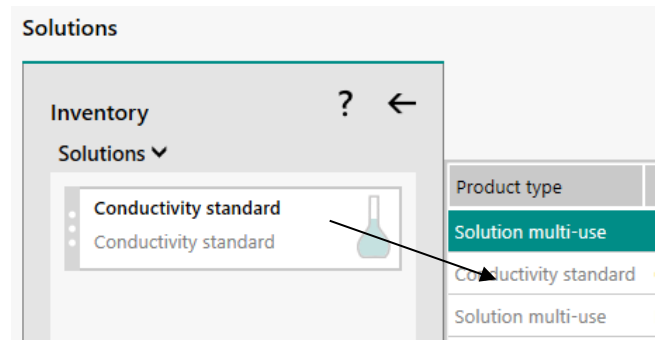

Figure 39: Creating a conductivity standard table

#	Temperature	κ	
1	18.0 °C	0.0873 mS/cm	X
2	19.0 °C	0.0894 mS/cm	X
3	20.0 °C	0.0909 mS/cm	X
4	21.0 °C	0.0927 mS/cm	X
5	22.0 °C	0.0947 mS/cm	X
6	23.0 °C	0.0969 mS/cm	X
7	24.0 °C	0.0986 mS/cm	X
8	25.0 °C	0.1000 mS/cm	X
9	30.0 °C	0.1106 mS/cm	X

Figure 40: Example of a conductivity standard table

In order to ensure compatibility with the methods provided, the created conductivity table must be named as described below:

'Conductivity standard'

2.2.11. Samples work area

Create a sample profile including the “TitrIC flex 2” OP. The numbers of subsamples for a sample is 1.

	Operating procedure	Number of subsamples
1	TitrIC flex 2	1

Figure 41: Example sample profile

Open a sample list, select the sample profile from the dropdown list, and click on the corresponding symbol to add a new sample.



Figure 42: Icon for the addition of a new sample

If you carried out a **titer determination**, keep in mind to manually enter the titer mean value into the titer field of the appropriate bottle cap under Equipment/Solutions/Properties/Specific data/Titer data.

You can also **create a separate sample profile** in OMNIS with the appropriate number of subsamples; for example 3 titer determinations = 3 subsamples. This is important for the correct execution of the “Titer write” command, which allows the automated calculation of the titer mean value and storage on to the used bottle cap.

Ensure that enough unexecuted sample lines are available in the sample list, meaning that there are the same number of samples in **OMNIS** (or more) as in the sample table in **MagIC Net**. Otherwise, the determination cannot be carried out properly.

There is also the possibility to import a **CSV file** template with 32 predefined samples. Proceed as follows:

1. The CSV file is included in the OP template ZIP file, which you can find on the **Knowledge base** at guide.metrohm.com (also see chapter 2.2.5).
2. Create the sample profile under *Samples / Sample profile* and name the sample profile: «**TitrIC flex 2**» (this must match the sample profile name in the first column of the CSV file).
3. Open an empty sample list and import the CSV file.

Name	No.	Name	Operating procedure	Determination start	Sample size
Sample	1	Subsample1	TitrIC flex 2		100 mL
Sample	2	Subsample1	TitrIC flex 2		100 mL
Sample	3	Subsample1	TitrIC flex 2		100 mL
Sample	4	Subsample1	TitrIC flex 2		100 mL
Sample	5	Subsample1	TitrIC flex 2		100 mL
Sample	6	Subsample1	TitrIC flex 2		100 mL
Sample	7	Subsample1	TitrIC flex 2		100 mL
Sample	8	Subsample1	TitrIC flex 2		100 mL

Figure 43: Example sample list to execute the OP

Prepare the samples for the analysis and enter the correct rack, sample position, and sample data of the determinations in **MagIC Net**.

In OMNIS the OPs are typically run in series determination.



Figure 44: Icon for series determination

First start the **MagIC Net** sample table followed by the **OMNIS** sample list.

3. TitrIC flex– Upgrade options

There are two packages suitable for the TitrIC flex setup:

Inline Eluent Preparation

Table 5: Configuration for Inline Eluent Preparation

No.	Article no.	Article designation
1	6.206.1120	System Connector
1	2.941.0010	941 Eluent Production Module
1	2.800.0010	800 Dosino
1	6.5330.090	IC Equipment: Additional Eluent on the Eluent Production Module
2	6.2769.110	Sensor EMPTY for 2 L bottles

The 941 Eluent Production Module enables the automatic production of eluents for continuous IC analyses over several weeks. It allows you to operate your IC system without manual intervention and guarantees stable retention times.

Discover

Table 6: Configuration Dis-Cover function

No.	Article no.	Article designation
1	6.02007.010	Lid tray for OMNIS Sample Robot S
1	6.02007.020	Lid trays for OMNIS Sample Robot M/L
1	6.05800.070	Lid tray upgrade for OMNIS Sample Robot S to M/L

1	6.02710.030	Dis-Cover lid for OMNIS 75 mL sample beaker, 25 pieces
1	6.02710.040	Dis-Cover lid for OMNIS 120 mL sample beaker, 16 pieces
1	6.02710.050	Dis-Cover lid for OMNIS 250 mL sample beaker, 9 pieces

The Sample Robot can be equipped with the Dis-Cover function, where a Dis-Cover lid covers the vials to prevent the solutions from evaporating and/or absorbing CO₂, which would result in a changed pH value. The lid is automatically removed just prior to the analysis.

For the installation, please consult with your local service technician and use the OP template “**TitrIC flex 2 Dis-cover**” for OMNIS.

4. TitrIC flex II – Flow chart

