

Application Bulletin 800105025EN

Installation instruction for MVA-22: 884 Professional VA fully automated with the Multi-Mode Electrode pro for trace analysis

The «MVA-22» is a fully automated system for voltammetric determinations.

- PC controlled operation.
- Manual operations:
 - Filling of the sample vials on the Autosampler with samples and rinsing solution.
- Automatic addition of 2 solutions: standard solution and electrolyte.
- Automatic rinsing of the measuring vessel.
- Method change during the determination series is possible.
- Example applications:
 - Cd, Pb and Cu in water samples
 - Pb in electroless Ni baths
 - 4-Carboxybenzaldehyde (4-CBA) in terephthalic acid



Fig. 1: MVA-22

Content

1. Instruments and accessories.....	2
2. System setup.....	2
2.1. Electrical connections	2
2.2. Tubing connections for rinsing and draining of the measuring vessel	2
2.3. Tubing connections with two dosing units.....	3
2.4. Tubing connections with four dosing units	5
3. viva «Configuration».....	6
3.1. Devices – 884 Professional VA.....	6
3.2. Sensors/Electrodes	6
3.3. Dosing units	6
3.4. Solutions	7
3.5. Devices – 919 IC Autosampler plus for VA	7
3.6. Additional solutions and dosing units	8
4. viva «Method»	9
4.1. Method run.....	9
4.2. Evaluation	11
5. Operation.....	11
5.1. Manual operation	11
5.2. Workplace.....	12
5.3. Course of events.....	12
6. Remarks.....	12
6.1. Storing dosing units	12
6.2. Storing electrodes.....	12
6.3. Waste bottle and waste container	12

1. Instruments and accessories

Quantity	Article number	
1	2.884.1110	884 Professional VA semiautomated MME
1	2.843.0240	843 Membrane Pump Station for Professional VA Systems
1	2.919.0130	919 IC Autosampler plus for VA
1	6.2141.300	Remote cable
1	6.5339.030	VA electrode kit 884 MME
1	6.6065.20X	viva 2.0

2. System setup

2.1. Electrical connections

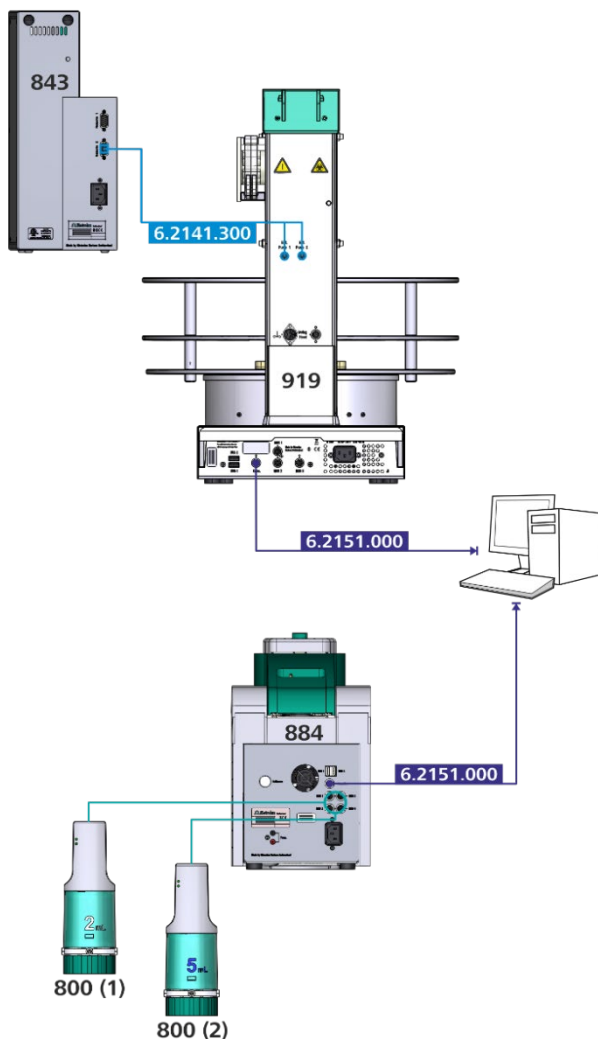
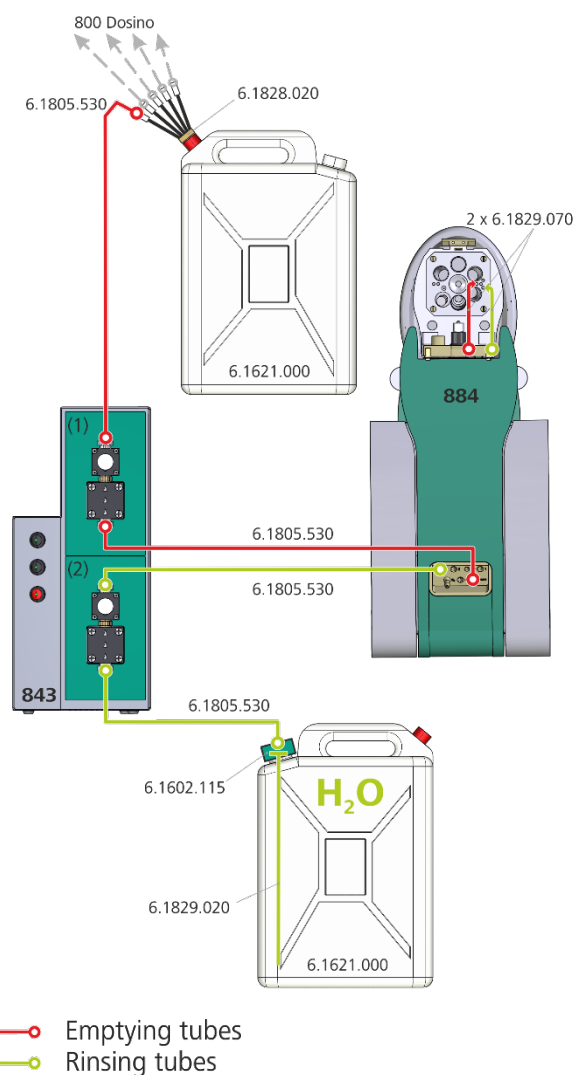

Fig. 2: Electrical connections

Please note!

- The cable 6.2141.300 has to be connected to «Remote 2» of the 843 Pump Station.
- The 800 Dosinos can be connected to any of the MSB ports. The indicated number is only used to distinguish the dosing units in this document.
- The controller cables 6.2151.000 from the 884 Professional VA and the 919 IC Autosampler plus should be directly connected to the PC. The connection should not be cascaded via the USB in the rear of the instruments.

2.2. Tubing connections for rinsing and draining of the measuring vessel



- Emptying tubes
- Rinsing tubes

Fig. 3: Tubing connections for rinsing and draining of the measuring vessel

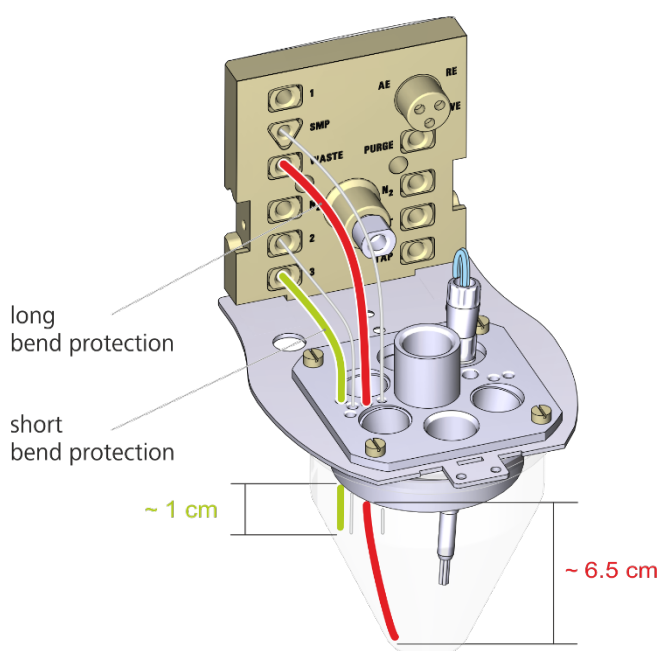
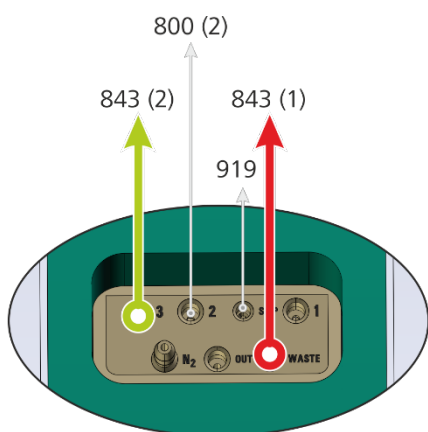

Fig. 4: Detailed view of the measuring head

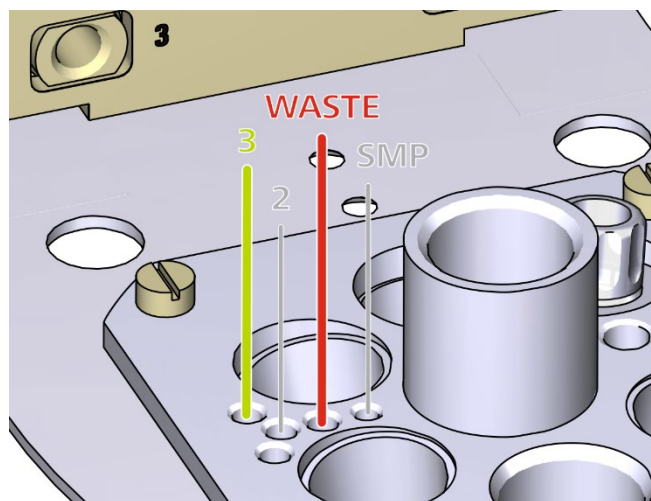

Fig. 5: Recommended draining and rinsing tube positions on the measuring head

Important:

- The drain tubing (WASTE) should be put through the rightmost of the four equally sized holes on the left side (see Fig. 5). This position is the most suitable for the measuring vessel for automated VA systems (6.1456.210).
- The rinse tubing (3) should be put through the uppermost of the four equally sized holes on the left side (see Fig. 5). Overlapping with the further installed tubes can be minimized this way.

2.3. Tubing connections with two dosing units

The equipment delivered with the MVA-22 contains two dosing units. As an example one can be used for standard addition and the other one for electrolyte. However, the setup is arranged according to the following scheme.

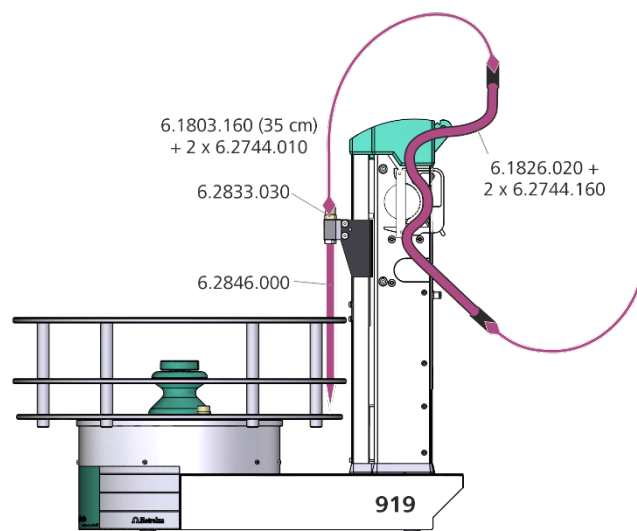
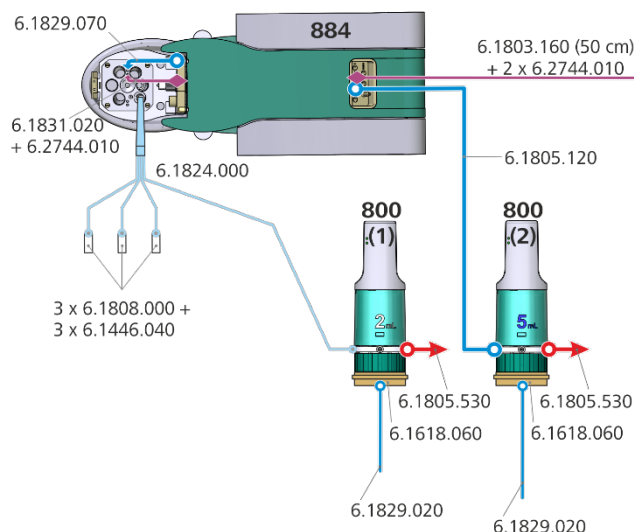

Fig. 6: Tubing connections for automatic dosing of standard and electrolyte with two dosing units

The aspiration tubes (6.1829.020) for the dosing units have to be cut to the appropriate length. With aid of the capillary cutter (6.2621.080) the aspiration tube should be cut approximately 2 mm above the bottom of the glass bottle. Approximate values are given in the following table:

Glass bottle	Approx. tubing length
6.1608.050 (100 mL)	12 cm
6.1608.090 (250 mL)	15 cm

It is recommended to guide the capillary over the cover of the tower of the 919 IC Autosampler plus for VA. For this purpose the PTFE capillary is fixed to the back of the tower by a capillary clamp (Y.107.0150) as shown in the following picture (Fig. 7):

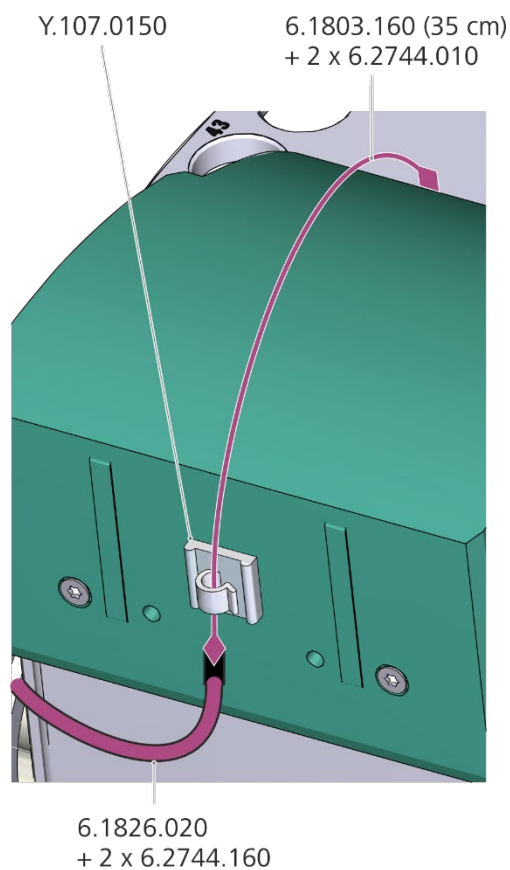

Fig. 7: Tube guide at the rear of the tower of the 919 IC Autosampler plus

Please make sure that the PVC pump tubing (6.1826.020) does not get caught under the tubing cartridge (6.2755.000) (see Fig. 8). Otherwise the PTFE tubing is too short and the tubing equipment might be damaged when the needle is lowered to the work position.

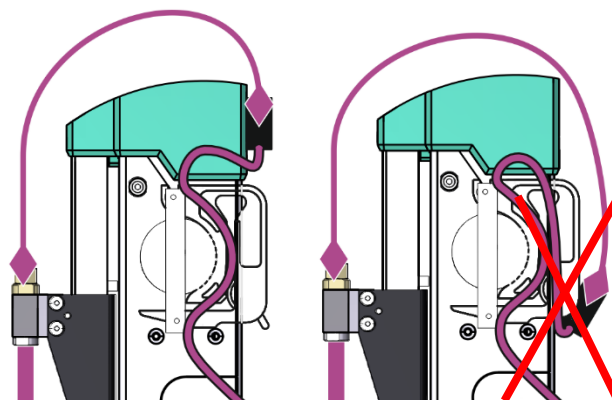

Fig. 8: Pumping tube installation

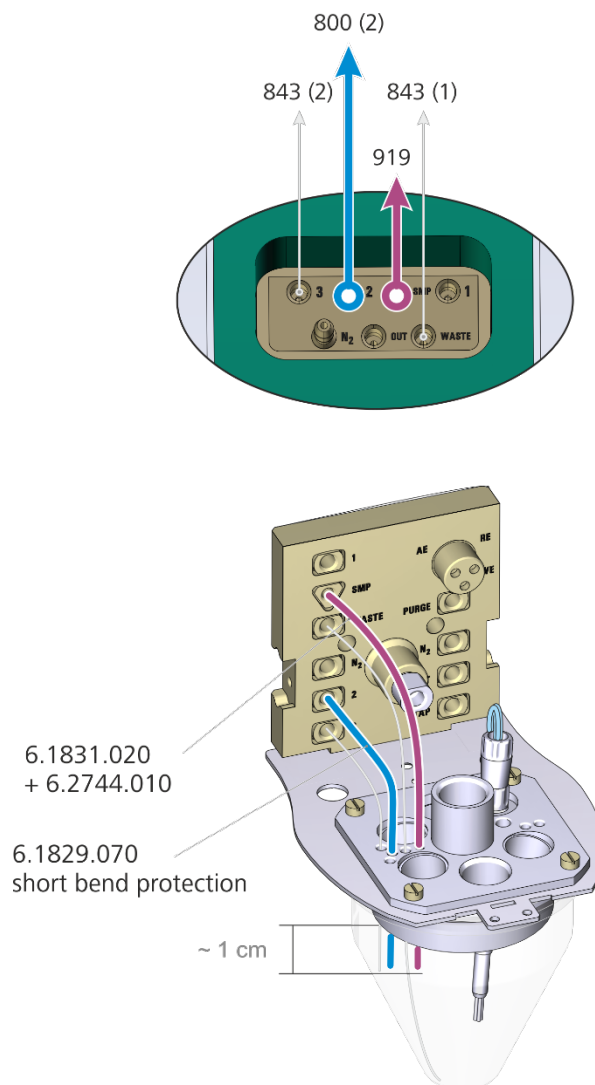

Fig. 9: Detailed view of the measuring head

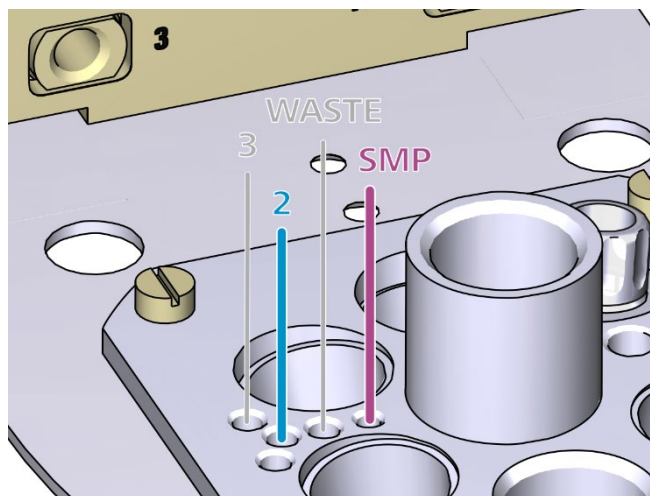

Fig. 10: Recommended electrolyte and sample tube positions on the measuring head

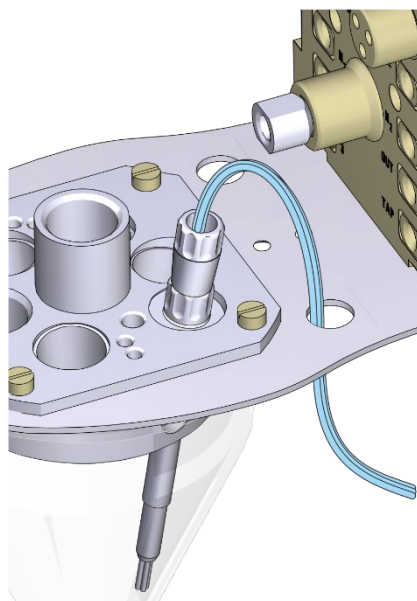

Fig. 12: Installation of the four way micro dosing tip

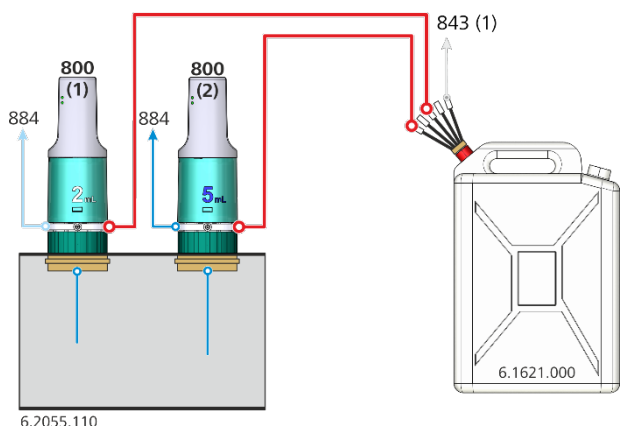

Fig. 11: Detailed view for the tubing connections of the dosing unit waste port

Important:

- It is recommended to use port 2 of the 884 Professional VA for the addition of the electrolyte if the instrument is used for both trace analysis and CVS, because port 1 is usually used for VMS in CVS applications. In this case port 1 should remain to be dedicated to VMS and port 2 for electrolyte to avoid cross-contamination.
- The electrolyte tubing should be put through the central one of the four equally sized holes on the left side to minimize overlapping with further installed tubes (see Fig. 10).
- The four-way micro dosing tip (6.1824.000) is guided through the opening on the right side (see Fig. 12).

2.4. Tubing connections with four dosing units

The MVA-22 can be extended by two dosing units using the following equipment:

Quantity	Article number	
1	6.5339.500	Equipment with two 2 mL dosing units, a bottle holder and two 100 mL glass bottles
2	2.800.0020	800 Dosino with cable 65 cm

The tubing connections for the extended system are shown in the following scheme.

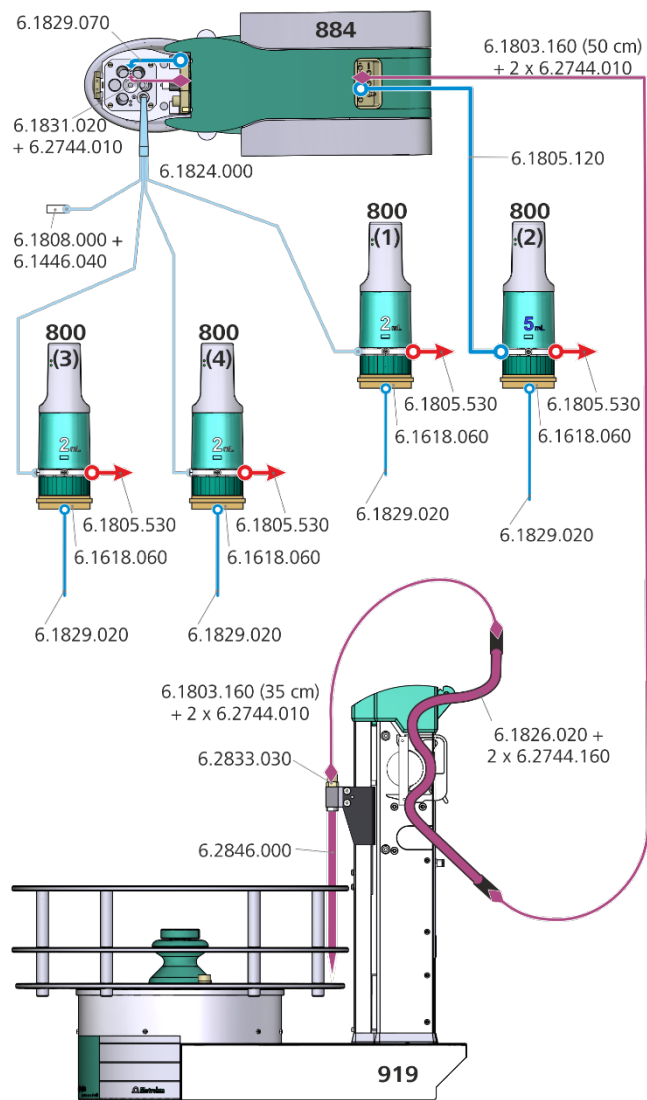

Fig. 13: Detailed view for the tubing connections of the MVA-22 with four dosing units

The tubings on the 884 Professional VA and the measuring head and the two 800 Dosinos are installed as described in the preceding chapters.

3. viva «Configuration»



In addition to this Application Bulletin it is recommended to have the following document available.

8.103.8033XX **viva** Tutorial Trace Analysis

In the following chapters it will be referred to as *Tutorial*

3.1. Devices – 884 Professional VA

The 884 Professional VA is automatically recognized by the **viva** software. When an instrument is connected for the first time it needs to be entered in the **viva** «Configuration». The corresponding dialog will pop up automatically.

Device name 884_1

For a step by step description please see the *Tutorial* chapter «4.1.1 Configuring the instrument».

3.2. Sensors/Electrodes

With the software a set of electrodes is preinstalled in the **viva** «Configuration». These default electrodes are used in the voltammetric commands in the **viva** method templates.

Sensor name	Sensor type
Auxiliary electrode	Auxiliary electrode
Reference electrode	Reference electrode
MME	MME
RDE	RDE/SSE
scTRACE Gold	scTRACE Gold

3.3. Dosing units

An 807 Dosing Unit attached to an 800 Dosino, which is connected to the 884 Professional VA, is automatically recognized by the **viva** software. When the dosing unit is connected for the first time it needs to be entered in the **viva** «Configuration». The corresponding dialog will pop up automatically. For a step by step description please see the *Tutorial* chapter «5.1.3 Configuring dosing units».

3.3.1. Dosing unit 2 mL at 800 Dosino (1)

Dosing unit name as used in the **viva** method templates.

Name	2 mL Standard
------	---------------

Parameters for preparation

Dosing port Prep/Empty	Dosing port 2	
Dosing rate Dosing port 1	2.0	mL/min
Dosing rate Dosing port 2	maximum	mL/min
Dosing rate Fill port	maximum	mL/min
Dosing rate Special port	maximum	mL/min

Tubing parameters

	Port	Length	Diameter
Dosing port 1	Port 1	80 cm	0.3 mm
Dosing port 2	Port 3	0 cm	2 mm
Fill port	Port 2	12 cm*	2 mm
Special port	Port 4	0 cm	2 mm

Valve disk

Rotating direction	automatic
--------------------	-----------

* to be measured

3.3.2. Dosing unit 5 mL at 800 Dosino (2)

Dosing unit name as used in the **viva** method templates.

Name	5 mL Electrolyte
------	------------------

Parameters for preparation

Dosing port Prep/Empty	Dosing port 2	
Dosing rate Dosing port 1	maximum	mL/min
Dosing rate Dosing port 2	maximum	mL/min
Dosing rate Fill port	maximum	mL/min
Dosing rate Special port	maximum	mL/min

Tubing parameters

	Port	Length	Diameter
Dosing port 1	Port 1	138 cm	2 mm
Dosing port 2	Port 3	0 cm	2 mm
Fill port	Port 2	15 cm*	2 mm
Special port	Port 4	0 cm	2 mm

Valve disk

Rotating direction	automatic
--------------------	-----------

* to be measured

3.4. Solutions

Solutions that should automatically be dosed have to be defined in the **viva** «Configuration» and need to be assigned to the dosing unit which is used for the dosing.

The following table shows the solution names and assigned dosing units as used in the **viva** method templates.

Solution name	Dosing unit
Standard	2 mL Standard
Electrolyte	5 mL Electrolyte

SOLUTION TYPE for «Standard» has to be **STANDARD SOLUTION**, for «Electrolyte» **AUXILIARY SOLUTION** is used.

For a step by step description please see the *Tutorial* chapter «5.1.4 Define solutions».

3.5. Devices – 919 IC Autosampler plus for VA

The «919 IC Autosampler plus for VA» is automatically recognized by the **viva** software. When an instrument is connected for the first time it needs to be entered in the **viva** «Configuration». The corresponding dialog will pop up automatically.

Device name	919 IC Autosampler plus 1
-------------	---------------------------

For a step by step description, please see the *Tutorial* chapter «6.1.1 Configuring the instruments».

3.5.1. Tower

Tower parameters

Max. stroke path	135	mm
Min. beaker radius	Off	
Lift rate	25	mm/s
Axial distance	196.0	mm

3.5.2. Rack

Rack name	6.2041.510	
Shift rate	20	°/s

3.5.3. Rack data

Rack parameters

Beaker radius samples	off	
Beaker sensor	off	
Rack offset	0	°

Lift positions – Tower 1

Work position	User defined, see 3.5.4	
Rinse position	0	mm
Shift position	0	mm

Special position	0	mm
------------------	---	----

Lift positions – Tower 2

Work position	Not available
Rinse position	Not available
Shift position	Not available
Special position	Not available

Special beakers

57*

* By default position 57 is defined as a special beaker. However, it is not used for trace analysis applications.

3.5.4. Needle adjustment



The work position of the sample transfer needle 6.2846.000 has to be adjusted in a way that the lower end of the needle is positioned max. 1 mm above the bottom of the sample vial. This is essential to guarantee a complete transfer of the sample from the sample vial on the rack of the 919 IC Autosampler plus into the measuring vessel of the 884 Professional VA.

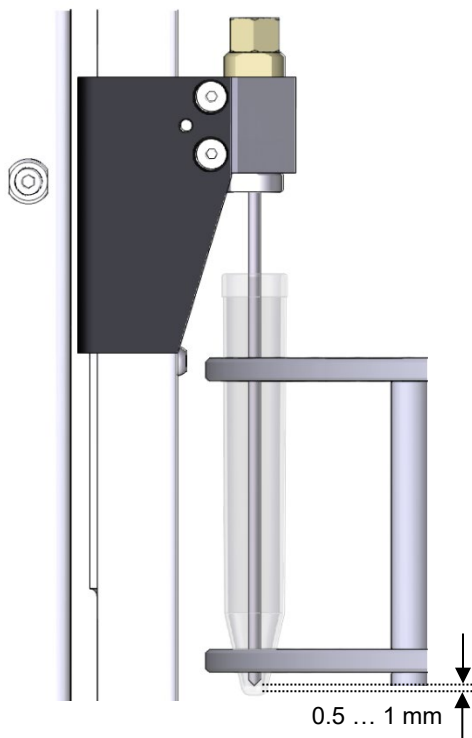

Fig. 14: Needle adjustment

Procedure to adjust the needle position in **viva**

1. Insert an empty sample vial to one of the sample positions on the rack (position 1 to 56).
2. Click on the «Manual» symbol.



3. Select Tower 1 (Sample changers – 919 IC Autosampler plus 1).
4. Open tab «Move».
5. Enter the position of the empty sample vial in the field «Target position».

Rack position

Current position: -----



Target position: []

6. Click «Start» to move the needle to the chosen rack position.
7. Enter 125 mm in the field «Target position» in the section «Lift position».

Lift position

Current position: [] mm

Target position: [125] mm

8. Click «Start» to lower the needle to the chosen target position. For the exact positioning of the needle as shown in «Fig. 14», use the arrow up and down buttons   to adjust the needle position stepwise.
9. Once the needle is properly adjusted select the tab «Assign position».
10. The new value can be seen in the section «Lift position – Current position».
11. Select the option «Work position for Tower» in the section «Lift position».

Lift position

Current position: [134] mm ● Work position for: [Tower]

12. Click on «Assign» in the section «Lift position».
13. Leave the «Manual control» with a click on the «Close» button.

3.6. Additional solutions and dosing units

If additional solutions are used they have to be defined in the **viva** «Configuration» as described in chapter «3.4 Solutions». The names can be given arbitrarily. However, care has to be taken to choose the correct solution type. If it is a standard solution (used for calibration) the solution type has to be «Standard solution». For all other solutions «Auxiliary solution» is chosen.

If the addition of the solutions should be done automatically by an 800 Dosino the dosing unit has to be configured as well. Therefore the steps described in chapter «3.3 Dosing units» of this document have to be carried out. It is important to enter the correct tubing dimensions in order not to damage the 800 Dosino and to ensure that after preparing the dosing unit all tubings are filled completely with the respective solution. Furthermore the solution has to be linked to the respective dosing unit in the **viva** «Configuration». The solution can now be used in a method with automatic dosing.

4. viva «Method»

4.1. Method run



The **viva** software includes one method template for trace analysis with an automated system.

- ASV determination (DP, standard addition), automated

The template already establishes the basic sequences for the different applications, the use of 800 Dosinos for automatic dosing, the use of a sample changer and pumps to process a sample series as well as the calculation of the result. However, certain commands and settings have to be adapted to the used hardware and the requirements of the specific application.

For a detailed description of the method template please see the *Tutorial* chapter «6.2 ASV determination automated with standard addition».

The following commands have to be adapted:

4.1.1. Voltammetric commands

Such as:

DP	ELECTRODE TEST
DP	Electrode test

- Select the 884 Professional VA instrument, the electrodes and, in case of sensor type MME, the operation mode to be used on the tab «General/Hardware».
- Adapt the measuring parameters on the tabs «Pre-treatment», «Sweep», «Post-treatment» and «Potentiostat» according to the requirements of the application. These parameters can be found in separate application documentation (e.g. Application Bulletin, Application Note, etc.).
- For the voltammetric command **ELECTRODE TEST** only the 884 Professional VA and the working electrode

has to be chosen. No measurement parameters can be changed except for the stirring rate.

4.1.2. Dosing commands

Such as:

ADD STD	ADD AUX
Add standard	Add electrolyte

- Select the solution name from the drop-down list to ensure the spelling exactly matches the entry in the configuration. In the **ADD STD** command only solutions with solution type «Standard» are listed.
- Define the volume of solution that should be dosed when these commands are carried out.

Such as:

LQH	LQH
Fill DU Standard	Fill DU Electrolyte

- On the tab «General/Hardware» select the name of the dosing unit which should be filled after the determination has finished.

4.1.3. Automation commands

Such as:

MOVE	LIFT	PUMP
MOVE to sample position	Needle → Work position	Peristaltic pump ON

- Assign the 919 IC Autosampler plus that should be used to run these commands.

4.1.4. Transferring sample

To ensure a complete transfer of the sample from the sample vial on the rack of the 919 IC Autosampler plus into the measuring vessel of the 884 Professional VA the peristaltic pump time has to be adjusted in the command **PUMP – PERISTALTIC PUMP ON** in the **TRACK – PERISTALTIC PUMP**.

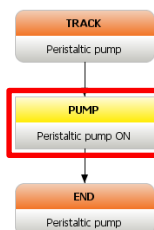

Fig. 15: Method snippet **TRACK – PERISTALTIC PUMP**

4.1.5. Rinsing measuring vessel

After each sample the measuring vessel needs to be rinsed with ultrapure water. The rinsing and draining times depend on the total volume used in the determination.

If the method template is used, the rinsing and draining times are defined in the corresponding **PUMP** commands in the **TRACK – RINSE** and **TRACK – DRAIN**. The number of rinsing cycles is defined in the command **LOOP – LOOP RINSING** in the **TRACK – RINSING CYCLE**.

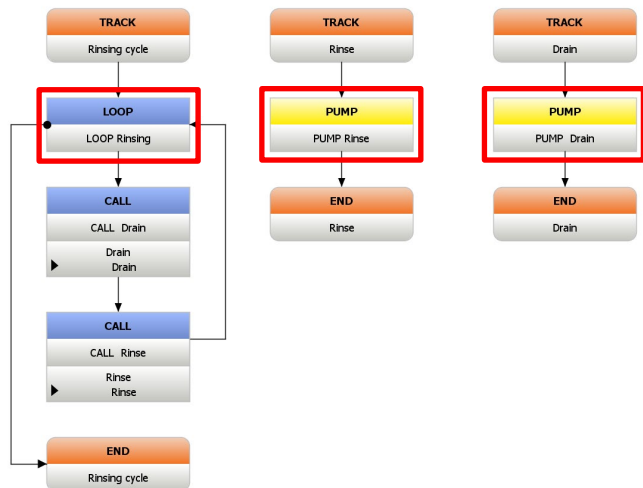

Fig. 16: Method snippet **TRACK – RINSING CYCLE**

Examples for rinsing and draining times:

Cell volume	10 mL	20 mL
Number of rinsing cycles	2	2
Draining time [s]	8	16
Rinsing time [s]	4	8

Please note! The device assigned to the commands **PUMP – PUMP RINSE** und **PUMP – PUMP DRAIN** needs to be the 919 IC Autosampler plus, since the 843 Pump Station is connected to and controlled from the sample changer.

4.1.6. Rinsing transfer tubing

After each sample the transfer tubing from the 919 IC Autosampler plus to the measuring vessel of the 884 Professional VA needs to be rinsed with ultrapure water. The rinsing solution is placed in a vial on the rack of the 919 IC Autosampler plus. The position of the rinsing solution relative to the sample position is defined in the command **MOVE – MOVE RINSING POSITION** in the **TRACK – GO TO RINSING POSITION**.

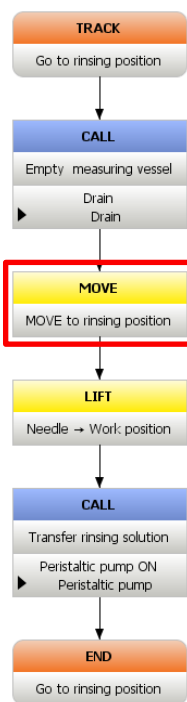

Fig. 17: Method snippet **TRACK – GO TO RINSING POSITION**

In the default setup positions 1 to 28 on the rack are used for sample vials and position 29 to 56 for rinsing solution. Due to this setup the rinsing solution for the sample on position 1 is on position 29, for sample 2 on position 30 and so on. This is reflected by the relative target number «Sample position + 28» in the command **MOVE – MOVE TO RINSING POSITION**. To change the relative position of the rinsing solution the formula editor has to be used on the parameter «Number» in the section «Target» by right-clicking into the value field.

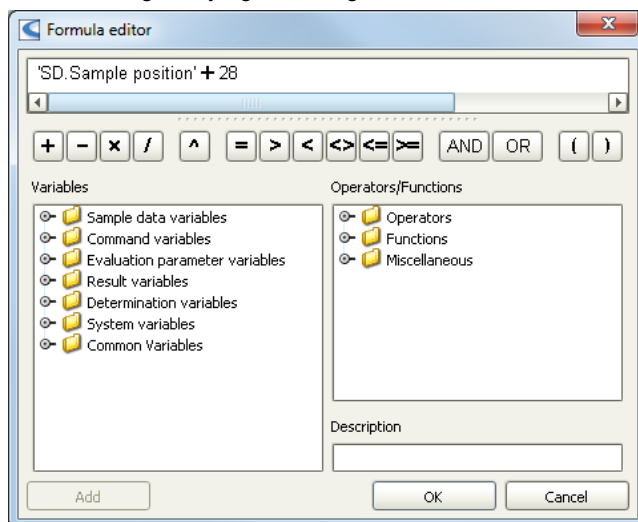

Fig. 18: Formula editor to change the rinsing position

The transfer time for the rinsing solution corresponds to the sample transfer time defined in the command **PUMP – PERISTALTIC PUMP ON** in the **TRACK – PERISTALTIC PUMP**.

4.2. Evaluation

Settings regarding evaluation and documentation of the determination are located in the «Evaluation» part of the method. The template includes all necessary settings to determine cadmium and lead. These settings have to be adapted to the particular application. For modification of substances please refer to the *Tutorial* chapter «4.2.3.2 Modify substances». Below is an overview where important parameters in the **viva** evaluation part can be found:

4.2.1. Substances

In the «Substances» part the analytes are listed and settings for peak recognition and baseline parameters are defined.

4.2.2. Standards

In the «Standards» part the analyte concentrations in the standard solutions are defined.

Important:

Independent from modifications on the substances click on **Edit** ▼ (or right mouse click on the standards table) and select «Apply from ADD STD». This is in order to ensure that the spelling of the standard solution in the table exactly matches the solution name in the **ADD STD** command. In case of inconsistent spelling, no calibration curve can be calculated.

Also define the concentrations of the standards according to the standard solutions used in your particular application.

4.2.3. Calibration

In the «Calibration» part the calibration method, such as «Standard addition» or «External calibration», is defined as well as the regression type.

4.2.4. Results

In the «Results» part on the tab «Results» the substances are listed for which the concentration is automatically calculated and displayed.

On the tab «Database» the database is defined where determinations should be stored. By default the database «viva» is used.

On the tab «Report» a report template for an automatic printout can be defined. By default no printout is defined.

5. Operation

The operation of the system is described on the basis of an automated ASV determination with the calibration method «standard addition».

5.1. Manual operation



- Dosing unit «2 mL Standard» has to be prepared with the standard solution.
- Dosing unit «5 mL Electrolyte» has to be prepared with the supporting electrolyte.
- Samples are placed on positions 1 to 28 of the sample rack. The exact sample volume needed for the determination has to be pipetted into the vial. Suitable volumes for this setup are between 5 and 10 mL.
- Rinsing solutions are placed on positions 29 to 56 of the sample rack. Usually the same volume of ultrapure water is used for rinsing like it was used for the sample. The rinsing solution has to be placed on the position «Sample position + 28».

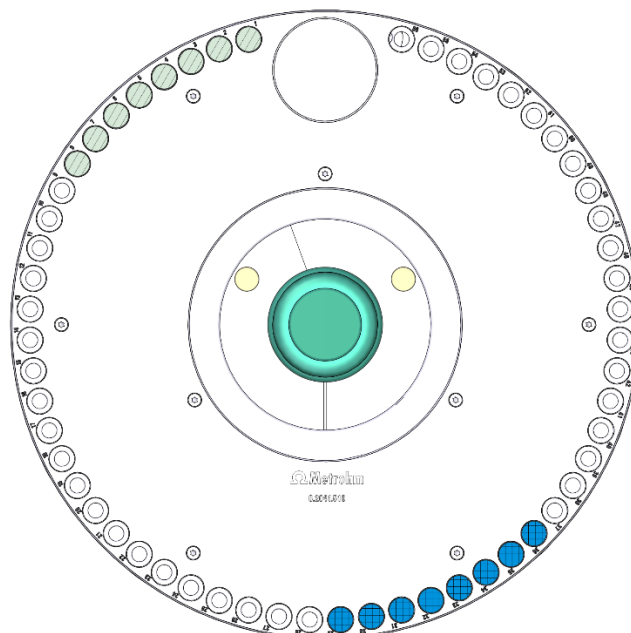

- Sample
- Rinsing solution

Fig. 19: Example positions of solutions on the sample rack
6.2041.510

5.2. Workplace



- In the «Run» window on the tab «Determination series» create a sample table

	Method	ID1	ID2	ID3	Sample type	Sample position	Sample amount	Sample amount unit
1	ASV determination (DP, standard addition) auto	Cd and Pb by DP-ASV	Blank		Sample	1	10	mL
2	ASV determination (DP, standard addition) auto	Cd and Pb by DP-ASV	Tap water sample		Sample	2	10	mL
3	ASV determination (DP, standard addition) auto	Cd and Pb by DP-ASV	Tap water sample		Sample	3	10	mL
4	ASV determination (DP, standard addition) auto	Cd and Pb by DP-ASV	Tap water sample		Sample	4	10	mL
5	ASV determination (DP, standard addition) auto	Cd and Pb by DP-ASV	Blank		Sample	5	10	mL
6	ASV determination (DP, standard addition) auto	Cd and Pb by DP-ASV	Tap water sample		Sample	6	10	mL
7	ASV determination (DP, standard addition) auto	Cd and Pb by DP-ASV	Tap water sample		Sample	7	10	mL
8	ASV determination (DP, standard addition) auto	Cd and Pb by DP-ASV	Tap water sample		Sample	8	10	mL
*								

Fig. 20: Example sample table for a determination by standard addition

- As sample type «Sample» has to be selected.
- For «Sample amount» the volume of sample pipetted into the vial has to be entered.

5.3. Course of events

- The execution of the determination by standard addition is controlled by the 884 Professional VA and **viva**.
 - The measuring vessel is emptied using the 843 Pump Station.
 - The sample is transferred from the sample rack to the measuring vessel of the 884 Professional VA by means of the built-in peristaltic pump of the 919 IC Autosampler plus.
 - The electrolyte is automatically dosed from the dosing unit «5 mL Electrolyte».
 - An electrode test is carried out to check, whether the electrodes are connected correctly and whether they are operational.
 - If the electrode test was successful, the solution is degassed for 5 minutes.
 - The sample is measured. Standard addition is carried out automatically with standard solution dosed from the dosing unit «2 mL Standard».
 - At the end of the determination the measuring vessel is emptied using the 843 Membrane Pump Station.
 - The transfer tubing from the sample changer to the measuring vessel is rinsed with the rinsing solution placed on the rack of the sample changer.
 - After the transfer tubing is rinsed the measuring vessel is automatically emptied and rinsed using the 843 Membrane Pump Station.
 - When the determination has finished the dosing units are automatically filled.

The next sample starts again from a).

6. Remarks

6.1. Storing dosing units

When the dosing units are not used (during the night, over the weekend) the dosing cylinder has to be rinsed with ultrapure water. For this purpose the «Prepare» function in the **viva** «Manual control» can be used.

6.2. Storing electrodes

When the electrodes are not used (during the night, over the weekend) all electrodes can be stored in ultrapure water. If they are not used for a longer period of time the reference electrode should be stored in $c(\text{KCl}) = 3 \text{ mol/L}$ (in case KCl is used as the bridge electrolyte). The working and auxiliary electrodes should be stored dry.

6.3. Waste bottle and waste container

The waste bottle as well as the waste container must not be closed completely. For pressure balancing, keep at least one opening unsealed. Overpressure would lead to a malfunction of the drain pump and possible damage to the 800 Dosinos.