

Column manual



Metrosep C Supp 1 (6.1052.4X0)

Manual

8.107.8043EN / 2015-08-06



Metrohm AG
CH-9100 Herisau
Switzerland
Phone +41 71 353 85 85
Fax +41 71 353 89 01
info@metrohm.com
www.metrohm.com

Column manual

Metrosep C Supp 1 (6.1052.4X0)

Manual

Technische Dokumentation
Metrohm AG
CH-9100 Herisau
techdoc@metrohm.com

This documentation is protected by copyright. All rights reserved.

This documentation has been prepared with great care. However, errors can never be entirely ruled out. Please send comments regarding possible errors to the address above.

Table of contents

1	General information	1
1.1	Ordering information	1
1.2	Technical specifications	1
2	Key aspects of working with separation columns	3
3	Eluent production	7
3.1	Chemicals	7
3.2	Production of the standard eluent	7
4	Start-up	9
4.1	Connecting and rinsing the guard column	9
4.2	Connecting the separation column	11
4.3	Conditioning	14
5	Applications	16
5.1	Standard chromatogram	16
5.2	Effects of temperature	17
5.3	Effect of the guard: RP 2 Guard vs C Supp 1 Guard	21
5.4	Variation of the eluent	23
5.5	Determining concentrations of trace metals in a magnesium sports drink	30
5.6	Ultratrace analysis of lithium and sodium in nuclear power plant samples with a monoethanolamine matrix	31
5.7	Trace analysis of standard cations and manganese, zinc and monoethanolamine	32
5.8	Determination of aliphatic amines	33
5.9	Analysis of tap water	34
5.10	Determination of biogenic amines in addition to the standard cations	35
5.11	Determination of choline in baby food	36
6	Troubleshooting	38
6.1	Regeneration	38
6.2	Decreasing resolution / peak shapes	39



6.3	Unstable retention times	40
6.4	Unknown peaks	40
6.5	Increasing backpressure	40
7	Literature	42
	Index	43

1 General information

This cation separation column is particularly suitable for the determination of cations, transition metals and amines with sequential suppression. Detection limits in the lowest µg/L range are achieved due to low baseline noise after sequential suppression.

1.1 Ordering information

Table 1 Columns

Order number	Designation
6.1052.410	Metrosep C Supp 1 - 100/4.0
6.1052.420	Metrosep C Supp 1 - 150/4.0
6.1052.430	Metrosep C Supp 1 - 250/4.0

Table 2 Guard columns

Order number	Designation
6.1052.500	Metrosep C Supp 1 Guard/4.0
6.1052.510	Metrosep C Supp 1 S-Guard/4.0

1.2 Technical specifications

Column material Polyvinyl alcohol with carboxyl groups

Particle size 5 µm

Dimensions

Order number	Dimensions
6.1052.410	100 x 4.0 mm
6.1052.420	150 x 4.0 mm
6.1052.430	250 x 4.0 mm

pH range 1 to 12

Temperature range 20 to 40 °C

Recommended standard temperature 40 °C

Maximum pressure 15 MPa (150 bar)



<i>Flow rate</i>	Order number	Recommended flow rate	Maximum flow rate
	6.1052.410	1.0 mL/min	1.5 mL/min
	6.1052.420	1.0 mL/min	1.5 mL/min
	6.1052.430	1.0 mL/min	1.5 mL/min
<i>Standard eluent</i>	5.0 mmol/L of nitric acid, 50 µg/L of rubidium (made of RbNO ₃ -salt)		
<i>Permitted organic additives</i>			
<i>In the eluent</i>	0 to 30% acetone, 0 to 50% acetonitrile, no methanol		
<i>In the sample matrix</i>	0 to 30% acetone, 0 to 50% acetonitrile, no methanol		
<i>Preparation</i>	1. Rinse the column with eluent for 2 h. To avoid high backpressure, we recommend rinsing the column after installation at a low flow rate (0.4 mL/min) for approx. 20 min.		
<i>Typical pressure</i>	For columns with a guard column under standard conditions with sequential suppression (MSM-HC C and MCS)		
	Order number	Typical pressure	
	6.1052.410	5.6 ± 2 MPa	
	6.1052.420	6.7 ± 2 MPa	
	6.1052.430	10.5 ± 2 MPa	
<i>Column housing</i>	Smart column with a chip, called an iColumn, made of PEEK		
<i>Application</i>	Used for separation of standard and transition metal cations as well as amines in a low concentration range. Conductivity detection after sequential suppression allows for low detection limits thanks to low baseline noise.		

2 Key aspects of working with separation columns

- Storage* Rinse the column with ultrapure water. Once the backpressure in your ion chromatograph has dissipated, remove the column at ambient temperature. Seal the column at both ends using the original stoppers (6.2744.060). Keep them refrigerated at 4 to 8 °C.
- Bacterial growth* Bacterial growth significantly affects chromatography and ruins separation columns. A vast array of problems in chromatography are caused by the growth of algae, bacteria and fungi.
- In order to prevent bacterial growth, always use fresh eluents, rinsing solutions and regeneration solutions. Do not use any solutions that have not been used for a prolonged period. We recommend cleaning all vessels as follows before filling them:
1. Thoroughly rinse with ultrapure, UV-treated water (> 18.2 MΩ).
 2. Swirl an acetone-water mixture around in the vessel.
 3. Rinse again with ultrapure water.
- If you notice the growth of bacteria or algae despite these precautionary measures, add 5% acetonitrile or acetone to the eluents. Only do this if you are *not using a membrane suppressor*. Membrane suppressors can be destroyed by organic solvents. The Metrohm Suppressor Module is 100% resistant to solvents.
- Chemical quality* All chemicals must have a quality of p.a. or puriss. Standard solutions must be intended specifically for ion chromatography.
- Chemical stress* Even though specifications may indicate that separation phases do cover a large pH range, this does not mean they are chemically inert. Separation columns last longest when subjected to constant chemical conditions. Never allow a column to dry out and ensure the column is sealed well at all times.
- Eluent bottles* The eluents are usually placed directly on the IC system in special eluent bottles. The bottles must feature an adsorber tube in order to prevent humidity and carbon dioxide from getting into the eluent. Normally, the adsorber tube is filled with a molecular sieve or—for sodium hydroxide and carbonate eluents—with soda lime (a weak CO₂ adsorber).
- Degassing the eluent* In order to prevent bubbles from forming, we recommend degassing the produced eluent before using it in your IC system. To degas the eluent, create a vacuum for approximately ten minutes using a water-jet pump

Regenerating separation columns

If separation columns are operated with clean eluents and filled with samples free of particles, you can expect the column to have a long service life. This means regenerating the column is not required and, after a multitude of injections, no longer possible.

If the pressure in the column increases unexpectedly despite this or the separation performance decreases, the regeneration steps specified for every column can be carried out. Generally it is important to keep in mind that the regeneration takes place outside the analytical line. Connect the separation column to the pump directly. Route the regeneration solution through the column directly into a waste container. Before reinstalling the separation column, it must be properly rinsed with fresh eluent.

Shutting down the ion chromatograph

If you will not be working with the ion chromatograph for a prolonged period (> 1 week), we recommend removing the separation column and sealing it with the stoppers provided. Rinse the ion chromatograph, including all three suppressor chambers, with methanol/water (1:4). Caution: Also rinse all three chambers of the suppressor. Store the separation column in the medium indicated on the column leaflet, ideally at a temperature between 4 and 8 °C.

When you return the instrument to operation, rinse the ion chromatograph with fresh eluent. Bring the separation column back up to the ambient temperature before you install it. Then increase the temperature if necessary.

Fun

Ion chromatography should be fun and should not stress you out. Metrohm puts all its work into ensuring you can work reliably with your IC systems with minimal maintenance, servicing and costs. Metrosep separation columns embody the attributes of quality, long service life and excellent results.

Environmental protection

A significant advantage of ion chromatography is that most of the work involves aqueous media. As a result, the chemicals used in ion chromatography are largely non-toxic and do not impact the environment. However, if you are working with acids, bases, organic solvents or heavy metal standards, dispose of them properly after use.

Guard columns

Guard columns are used to protect separation columns. We strongly recommend their use. They normally contain the same stationary phase also used in the separation columns. However, the quantity is significantly reduced to avoid impacting the chromatography. Guard columns remove critical contaminants that could react with column material; they also effectively remove particles and bacterial contaminants. Replace the guard column in the following cases:

- If the backpressure in the system increases
- If the chromatography results deteriorate



Guard columns are available for all Metrosep separation columns. We recommend replacing the guard column three to four times during the service life of the analytical column.

Water quality

Aqueous media is used in most work involving ion chromatography. This means water quality is a critical factor for good chromatography. If the water quality is inadequate, the results will be as well. In addition, there is a risk of damaging instruments and separation columns when using water with inadequate quality. The ultrapure water being used should have a specific resistivity greater than 18.2 M Ω ·cm and should be free of particles. Therefore, we recommend filtering the water using a 0.45 μ m filter and treating it with UV light. Modern ultrapure water systems for laboratory use ensure this level of water quality (Type I).

3 Eluent production

We recommend choosing a high level of purity for chemicals for both standard production and eluent production.

3.1 Chemicals

Recommended chemicals

- Nitric acid, HNO₃, 2 mol/L
Sigma Aldrich order number: 35278
- Rubidium nitrate, RbNO₃, 99.7%
Sigma Aldrich order number: 289299
- Ultrapure water of type I (see ASTM D1193)
Resistance > 18.2 MΩ·cm (25 °C)
TOC < 10 µg/L

3.2 Production of the standard eluent

Proceed as follows to produce 2 L of standard eluent with 5.0 mmol/L of nitric acid and 50 µg/L of rubidium:

Producing 2 L of standard eluent

- 1 ▪ Prerinse the eluent bottle with ultrapure water several times.
▪ Set out 1.9 L of ultrapure water.
- 2 If the eluent is not degassed using an eluent degasser:
 - Degas the ultrapure water for the eluent using a vacuum pump. This prevents problems with air bubbles in the high-pressure pump.
- 3 Producing a stock solution of 1g/L of rubidium (=1000 ppm):
 - Weigh 86.27 mg of rubidium nitrate salt
 - Dissolve in 50 mL of ultrapure water
- 4 Producing eluents:
 - Pipette 100 µL of the rubidium stock solution into the eluent bottle.
 - Pipette 5 mL of the 2 mol/L nitric acid into the eluent bottle.
 - Fill the eluent bottle with ultrapure water to 2 L.



- Stir briefly.

This eluent (5.0 mmol/L of nitric acid and 50 µg/L of rubidium) and sequential suppression can be used to achieve background conductivity of < 0.3 µS/cm. The noise is typically less than 0.1 nS/cm.

4 Start-up

4.1 Connecting and rinsing the guard column

Guard columns protect separation columns and significantly increase their service life. The guard columns available from Metrohm are either actual guard columns or guard column cartridges used together with a cartridge holder. The process of installing a guard column cartridge into the corresponding holder is described in the leaflet of the guard column.



NOTE

Metrohm recommends always working with guard columns. They protect the separation columns and can be replaced regularly as needed.



NOTE

Information regarding which guard column is suitable for your separation column can be found in the **Metrohm IC Column Program** (which is available from your Metrohm representative), the leaflet provided along with your separation column or the product information about the separation column at <http://www.metrohm.com> (Ion Chromatography product area), or obtained directly from your representative.



CAUTION

New guard columns are filled with solution and sealed with stoppers or caps on both sides.

Before inserting the guard column, ensure that this solution can be mixed with the eluent being used (follow information from the manufacturer).



NOTE

The guard column may not be connected until after the instrument has already been put into operation once. The guard column and separation column have to be replaced by a coupling (6.2744.040) until then.

Accessories

For this step you need the following accessories:

- Guard column (suitable for the separation column)

Connecting the guard column

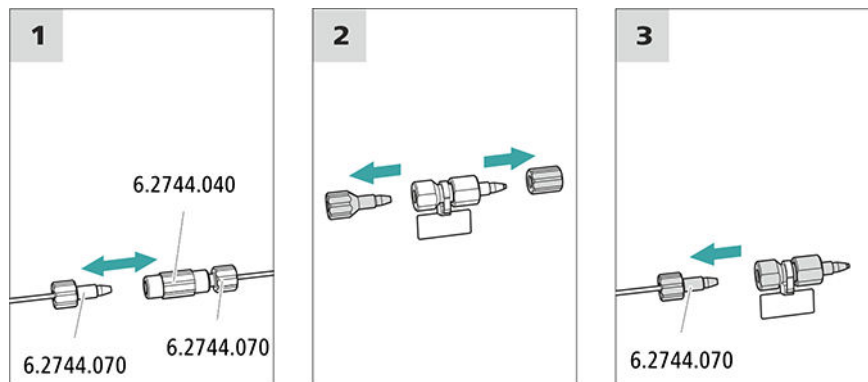

1 Removing the coupling

Remove the coupling installed between the column inlet capillary and the column outlet capillary for the initial start-up.

2 Preparing the guard column

- Remove the stopper and the sealing cap from the guard column.

3 Connecting the guard column



CAUTION

When inserting the guard column, ensure that it is inserted correctly based on the marked flow direction (if specified).

- Fasten the inlet of the guard column to the column inlet capillary using a short pressure screw (6.2744.070).
- If the guard column is connected to the separation column using a connection capillary, fasten this connection capillary to the guard column outlet with a pressure screw.

Rinsing the guard column

1 Rinsing the guard column

- Place a beaker under the guard column's outlet.

- Start manual control in MagIC Net and select the high-pressure pump: **Manual ► Manual control ► Pump**
 - **Flow: in accordance with the column leaflet**
 - **On**
- Rinse the guard column with eluent for approx. 5 minutes.
- In the manual control in MagIC Net, stop the high-pressure pump again: **Off**.

4.2 Connecting the separation column

The intelligent separation column (iColumn) is the heart of the ion chromatographic analysis. It separates the different components according to their interactions with the column. Metrohm separation columns are equipped with a chip where their technical specifications and history (start-up, operating hours, etc) are stored.



NOTE

Information regarding which separation column is suitable for your application can be found in the **Metrohm Column Program**, the product information for the separation column or obtained through your representative.

You can find product information for your separation column at <http://www.metrohm.com> in the Ion Chromatography product area.

Information on separation columns and guard columns available from Metrohm can be found in the Metrohm Column Program or online at <http://www.metrohm.com> in the Ion Chromatography product area. A test chromatogram and a leaflet accompanies every column. Detailed information on special IC applications can be found in the corresponding "**Application Bulletins**" or "**Application Notes**". You can find these online at <http://www.metrohm.com> in the Applications area or request them from your responsible Metrohm representative free of charge.



CAUTION

New separation columns are filled with solution and sealed with stoppers on both sides. Before inserting the column, ensure that this solution can be mixed with the eluent being used (follow information from the manufacturer).



NOTE

Do not connect the separation column until starting work with the instrument for the first time. Until that point, insert a coupling (6.2744.040) instead of the guard column and separation column.

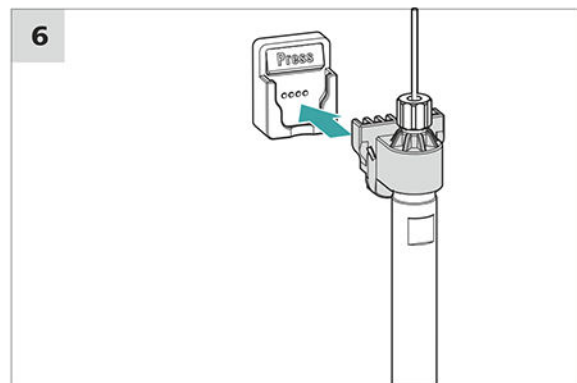
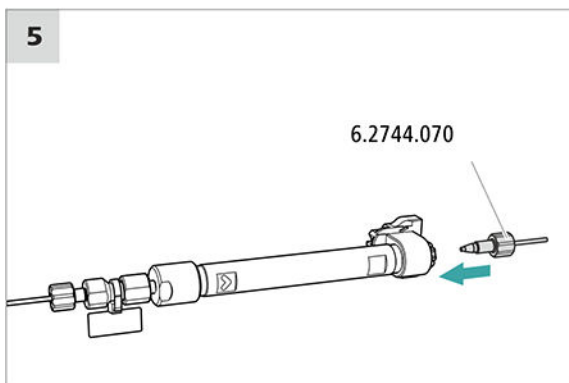
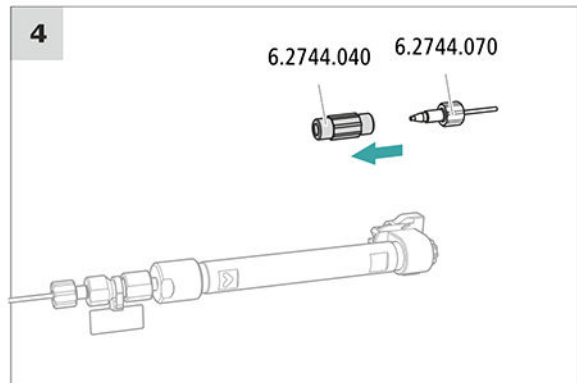
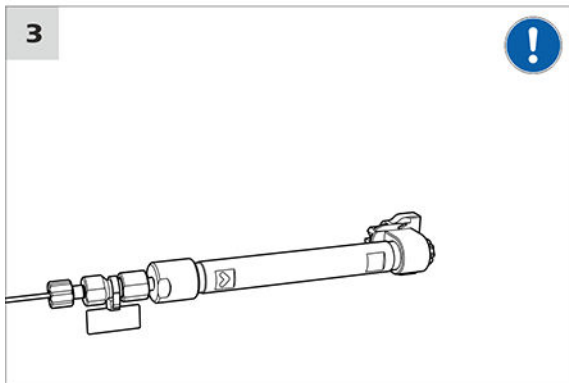
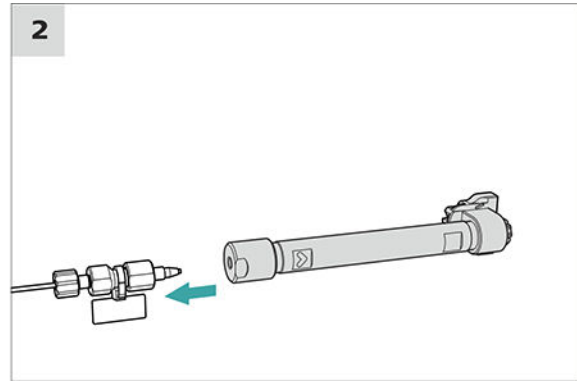
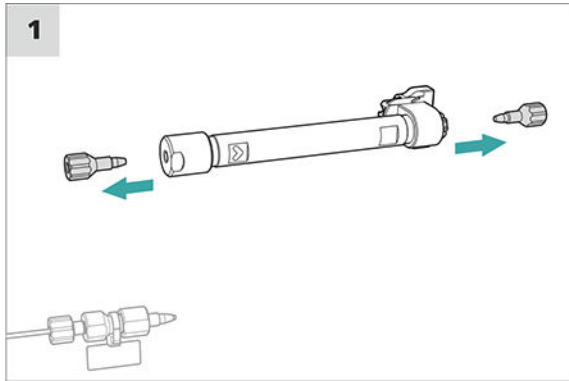

Rinse the separation column as follows.

Connecting the separation column

1 Removing the stoppers

- Remove the stoppers from the separation column.

2 Installing the inlet of the separation column



CAUTION

When inserting the column, ensure that it is inserted correctly based on the marked flow direction.

There are three options:

- Attaching the bottom end of the separation column directly to the guard column.
or
- If the guard column is connected to the separation column using a connection capillary: Connect the bottom end of the separation column to the guard column outlet capillary using a PEEK pressure screw (6.2744.070).
or
- If no guard column is used (not recommended), connect the column inlet capillary to the inlet of the separation column using a short pressure screw (6.2744.070).

3 Rinsing the separation column

- Place a beaker under the outlet of the separation column.
- Start manual control in MagIC Net and select the high-pressure pump: **Manual ► Manual control ► Pump**
 - Flow: in accordance with the column leaflet**
 - On**
- Rinse the separation column with eluent for approx. 10 minutes.
- In the manual control in MagIC Net, stop the high-pressure pump again: **Off**.

4 Removing the coupling

- Remove the coupling (6.2744.040) from the column outlet capillary.

5 Installing the outlet of the separation column

- Fasten the column outlet capillary to the upper end of the separation column using a PEEK pressure screw (6.2744.070).

6 Inserting the separation column

- Insert the separation column with chip into the column holder until you hear it snap in place.

The separation column is now detected by MagIC Net.

4.3 Conditioning

In the following cases, the system must be conditioned with eluent until a stable baseline has been reached:

- After installation
- After each time the instrument is switched on
- After each eluent change

**NOTE**

The conditioning time can lengthen considerably after changing the eluent.

Conditioning the system**1 Preparing the software****CAUTION**

Ensure that the configured flow rate is not higher than the flow rate permitted for the corresponding column (refer to the column leaflet and chip data record).

- Start the **MagIC Net** computer program.
- Open the **Equilibration** tab in MagIC Net: **Workplace ► Run ► Equilibration**.
- Select (or create) a suitable method.
Also see: *MagIC Net Tutorial* and online help.

2 Preparing the instrument

- Ensure that the column is inserted correctly in relation to the flow direction marked on the sticker (arrow has to point in the direction of flow).
- Ensure that the eluent aspiration tubing is immersed in the eluent and that there is enough eluent in the eluent bottle.

3 Starting equilibration

- Start the equilibration in MagIC Net: **Workplace ► Run ► Equilibration ► Start HW**.
- Visually inspect whether all capillaries and their connections from the high-pressure pump to the detector are leak-tight. If eluent is leaking out anywhere, tighten the corresponding pressure screw further, or loosen the pressure screw, check the end of the capillary and shorten it using the capillary cutter if necessary and retighten the pressure screw.

4 Conditioning the system

Continue rinsing the system with eluent until the desired stability level has been attained for the baseline.

The instrument is now ready for measuring samples.



5 Applications

5.1 Standard chromatogram

Sample preparation:	-
Detection:	Conductivity
Suppression:	Sequential suppression with MSM-HC C and MCS
Temperature:	40 °C
Loop:	20 µL
Flow rate:	1.0 mL/min
Eluent:	5.0 mmol/L of nitric acid and 50 µg/L of rubidium

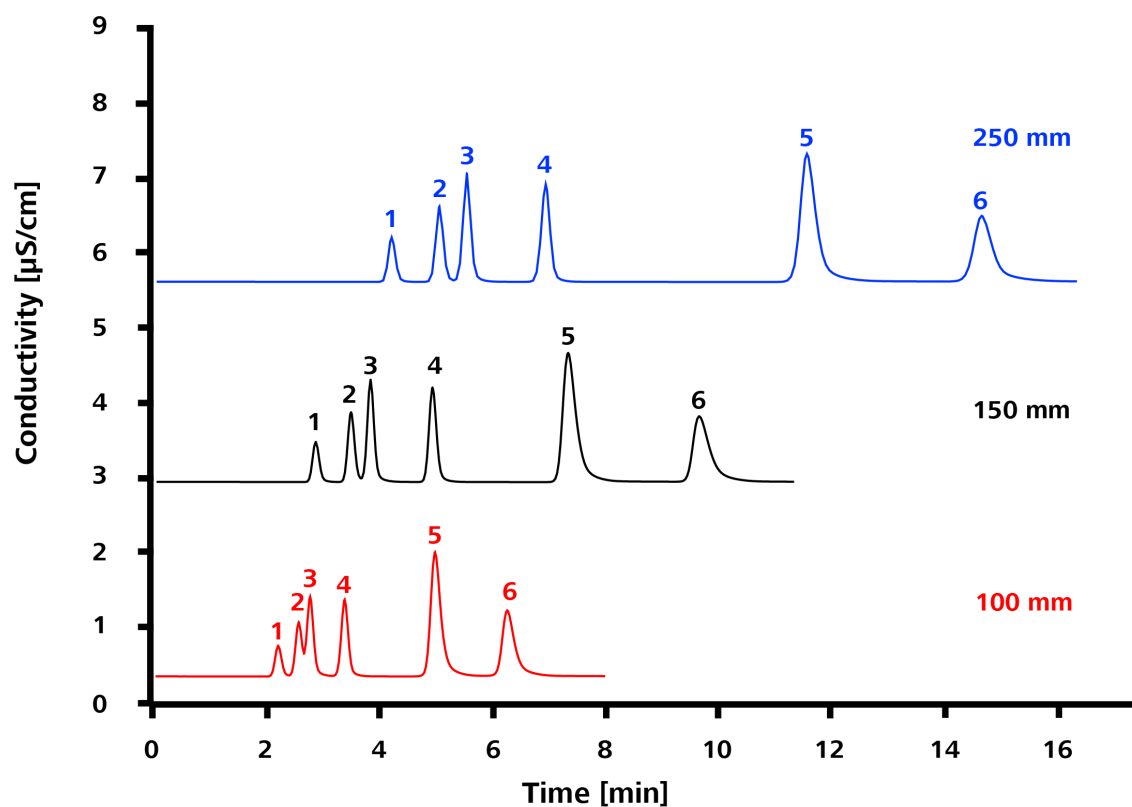

C Supp 1 - XX0/4.0

- 1 1 mg/L of lithium
- 2 5 mg/L of sodium

C Supp 1 - XX0/4.0

- | | |
|---|----------------------|
| 3 | 5 mg/L of ammonium |
| 4 | 10 mg/L of potassium |
| 5 | 10 mg/L of magnesium |
| 6 | 10 mg/L of calcium |
-

5.2 Effects of temperature

<i>Column</i>	Metrosep C Supp 1 - 250/4.0
<i>Sample preparation:</i>	-
<i>Detection:</i>	Conductivity
<i>Suppression:</i>	Sequential suppression with MSM-HC C and MCS
<i>Temperature:</i>	20 to 40 °C
<i>Loop:</i>	20 µL
<i>Flow rate:</i>	1.0 mL/min
<i>Eluent:</i>	5.0 mmol/L of nitric acid and 50 µg/L of rubidium

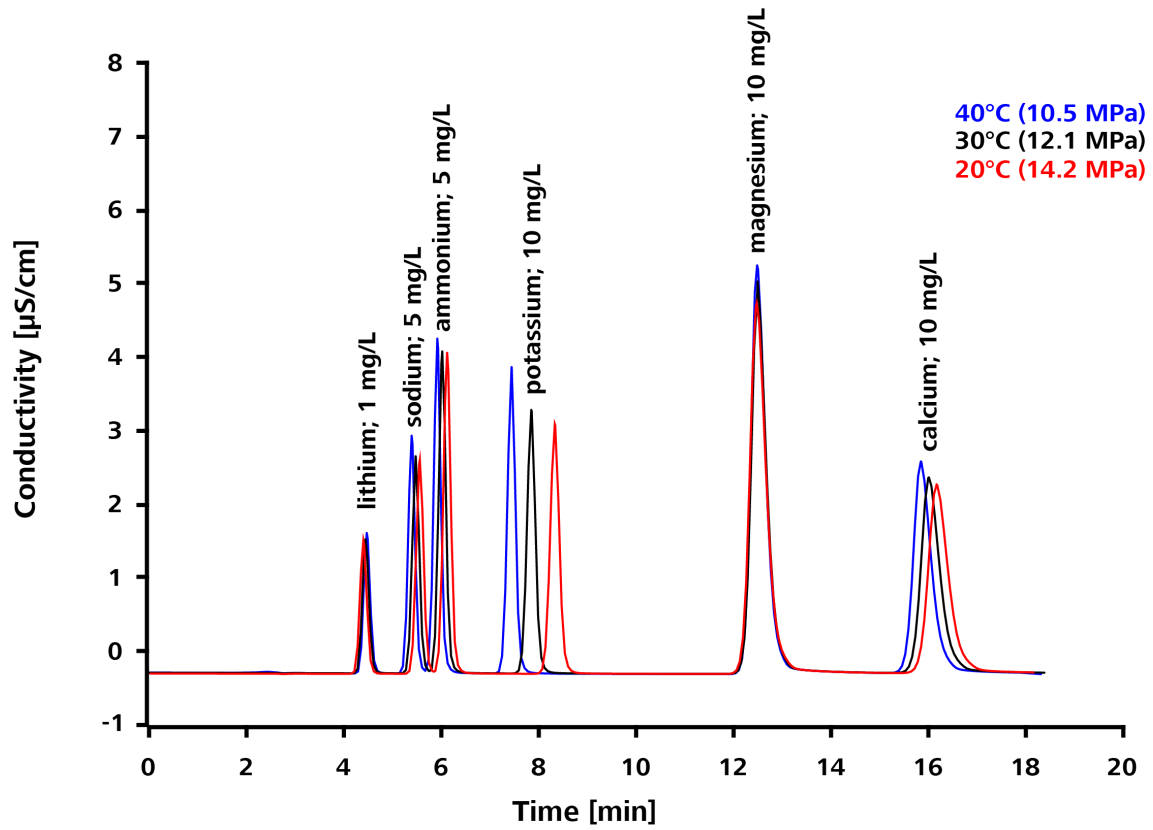

Monovalent ions, especially potassium, have shorter retention times at higher temperatures.

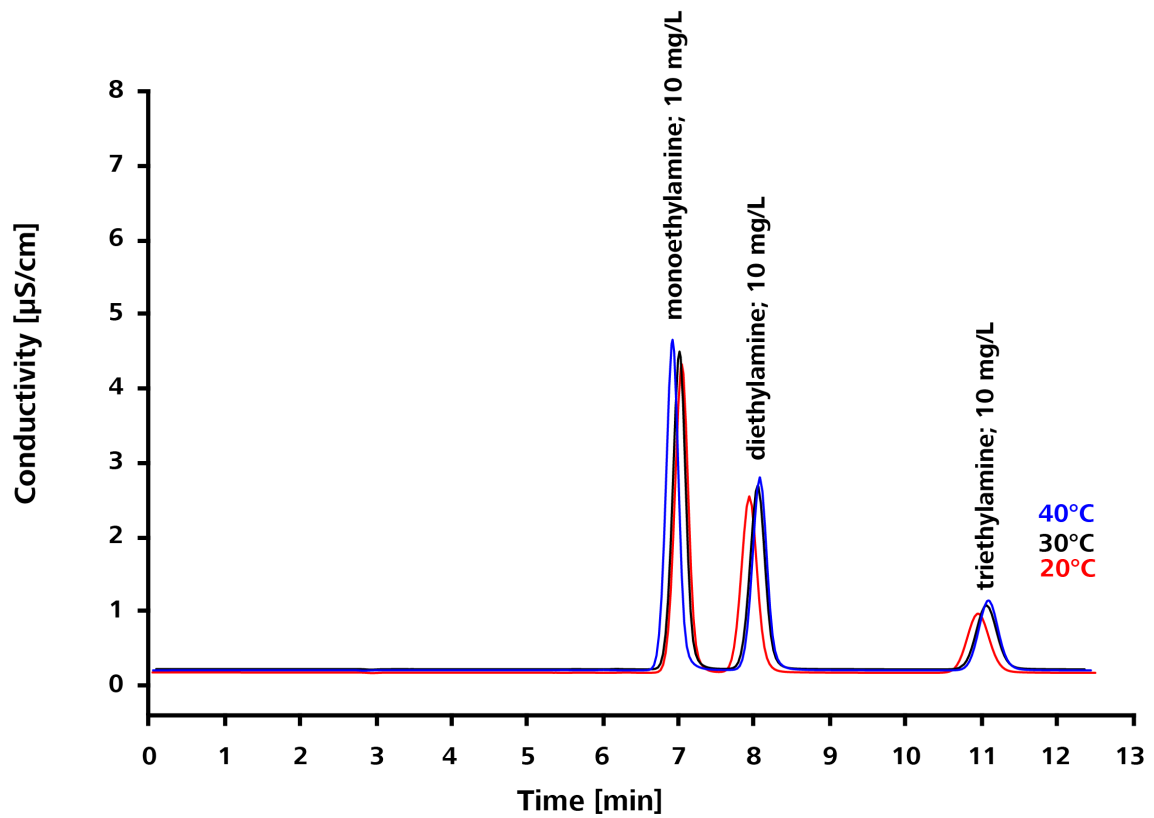

Diethylamine and triethylamine tend to have slightly longer retention times at higher temperatures, whereas retention times for ethylamine tend to be slightly shorter.

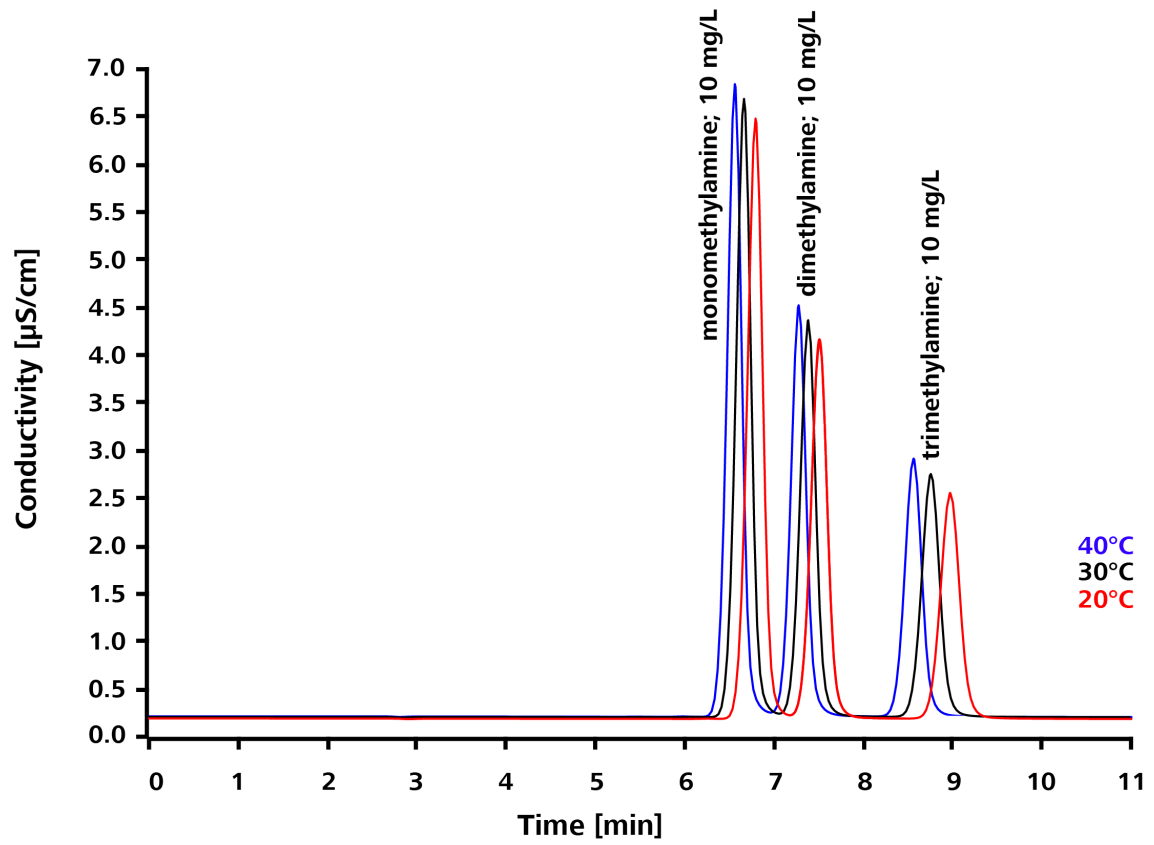

At a higher temperature, a slight reduction in retention times for methylamines can be observed.

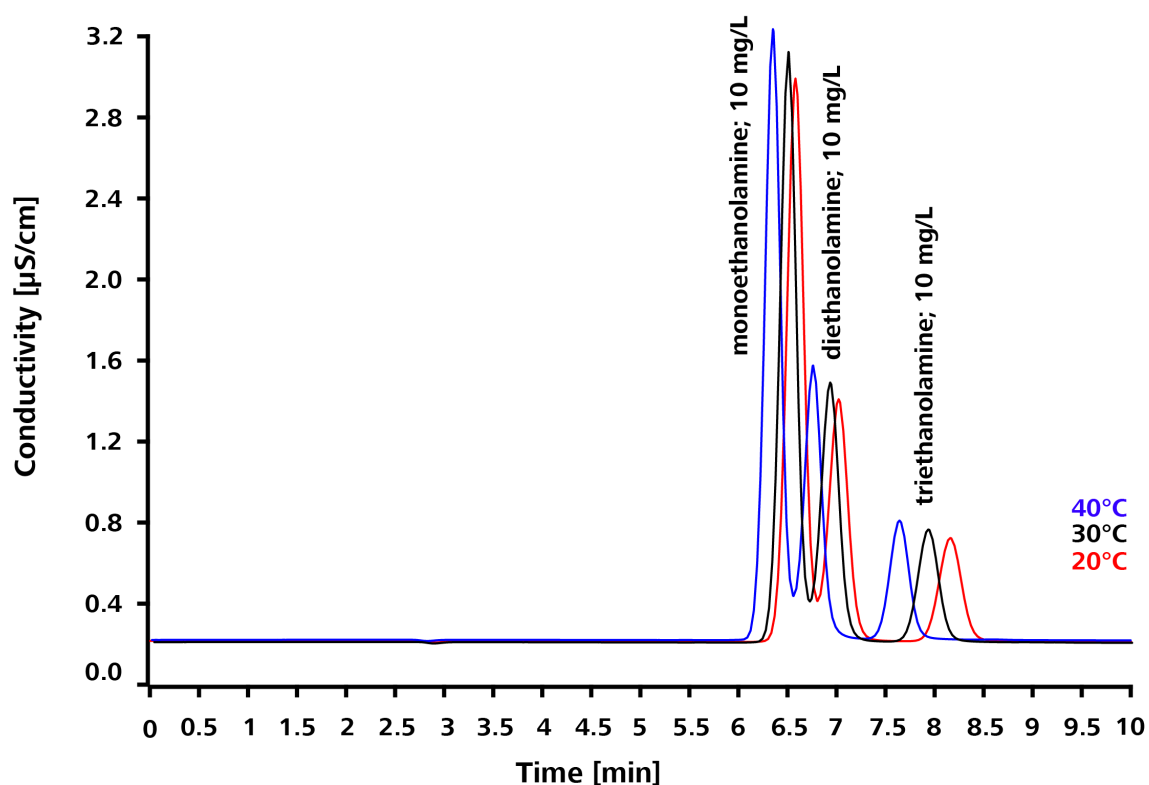

At a higher temperature, a reduction in retention times for ethanolamines can be observed.

5.3 Effect of the guard: RP 2 Guard vs C Supp 1 Guard

<i>Column</i>	Metrosep C Supp 1 - 250/4.0
<i>Sample preparation:</i>	-
<i>Detection:</i>	Conductivity
<i>Suppression:</i>	Sequential suppression with MSM-HC C and MCS
<i>Temperature:</i>	40 °C
<i>Loop:</i>	20 µL
<i>Flow rate:</i>	1.0 mL/min
<i>Eluent:</i>	5.0 mmol/L of nitric acid and 50 µg/L of rubidium

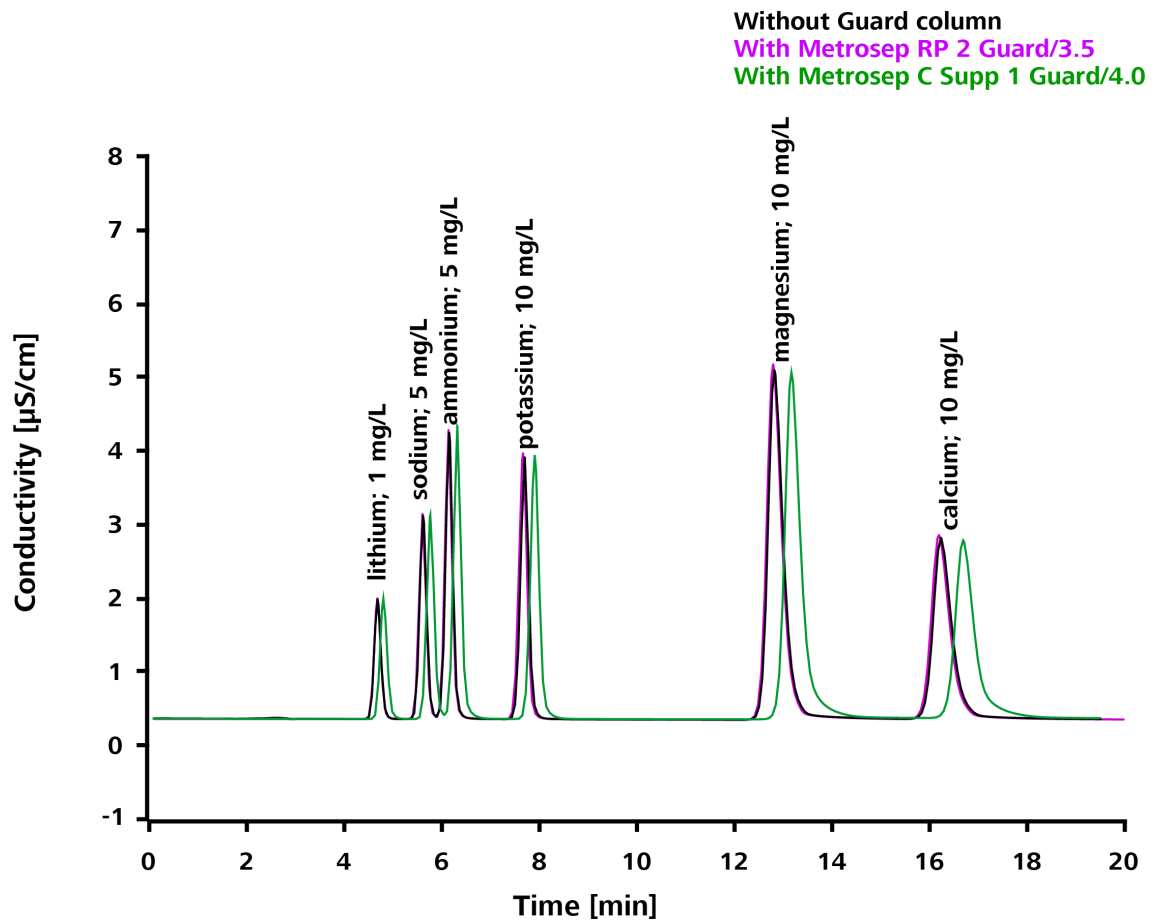

The Metrosep C Supp 1 Guard/4.0 slightly increases the capacity and, therefore, has somewhat longer retention times. The Metrosep RP 2 Guard/3.5 does not influence the separation and produces the same retention times as a column without guard.

The Metrosep RP 2 Guard/3.5 can be used as an alternative guard since no effect on the chromatography has been observed.

5.4 Variation of the eluent

Variation of the HNO₃ concentration

Column	Metrosep C Supp 1 - 250/4.0
Sample preparation:	-
Detection:	Conductivity
Suppression:	Sequential suppression with MSM-HC C and MCS
Temperature:	40 °C
Loop:	20 µL
Flow rate:	1.0 mL/min
Eluent:	3.0, 5.0, 7.0 and 9.0 mmol/L of nitric acid and 50 µg/L of rubidium

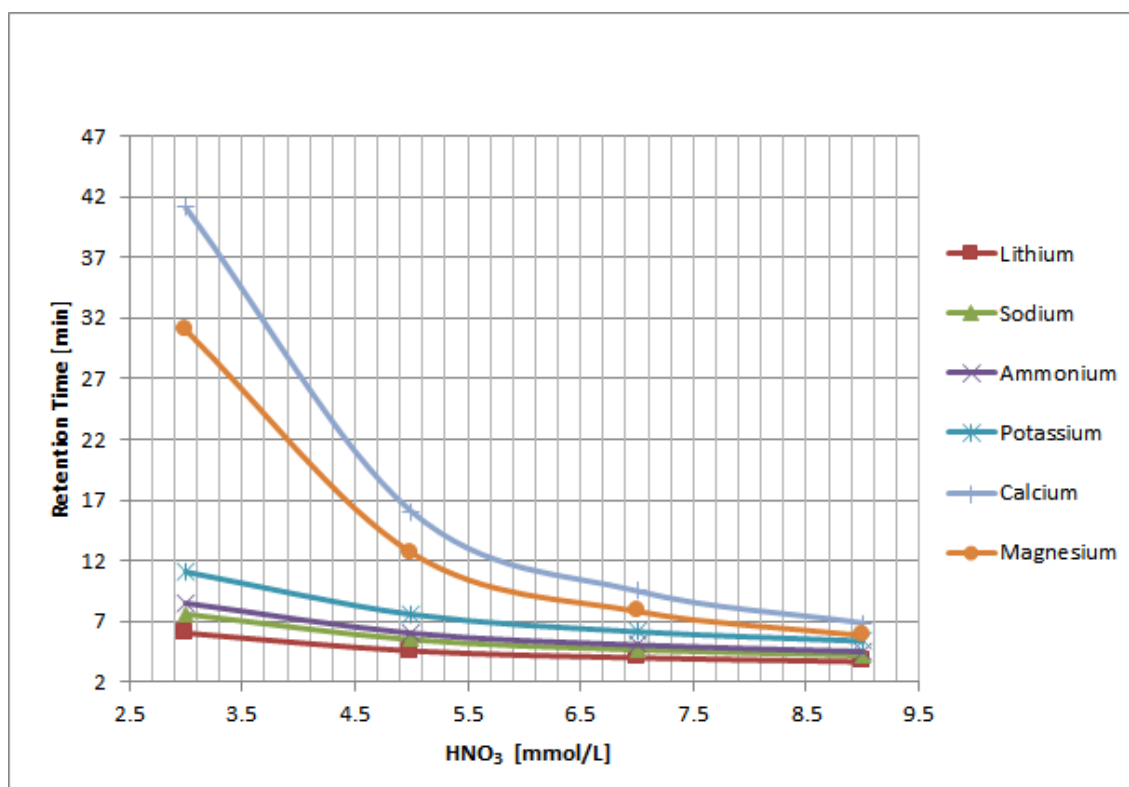

Figure 1 Nitric acid variations – Standard cations

When using stronger eluents, polyvalent cations such as magnesium and calcium are accelerated disproportionately to the monovalent cations.

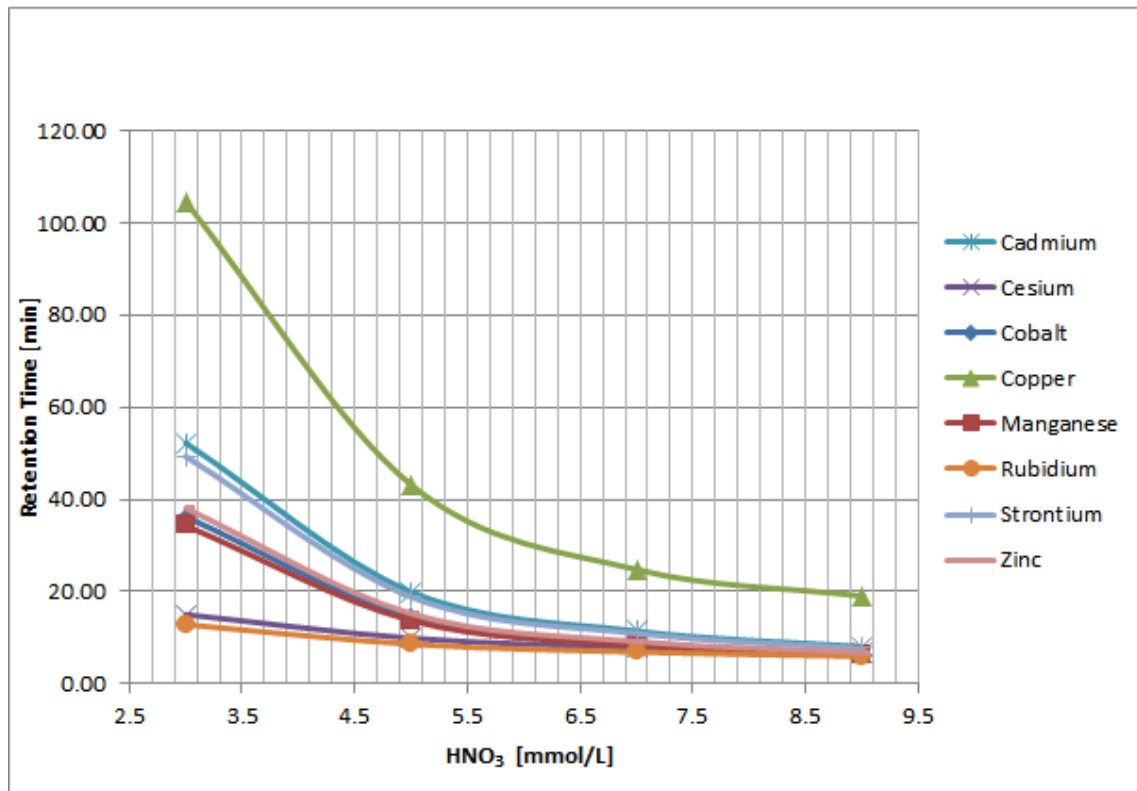

Figure 2 Nitric acid variations – Transition metals

Transition metals are also greatly accelerated when the eluent concentration is increased. Copper elutes as an extremely wide peak. With an eluent of 5 mmol/L of HNO₃, a 10-mg/L copper peak is approximately 20 minutes wide.

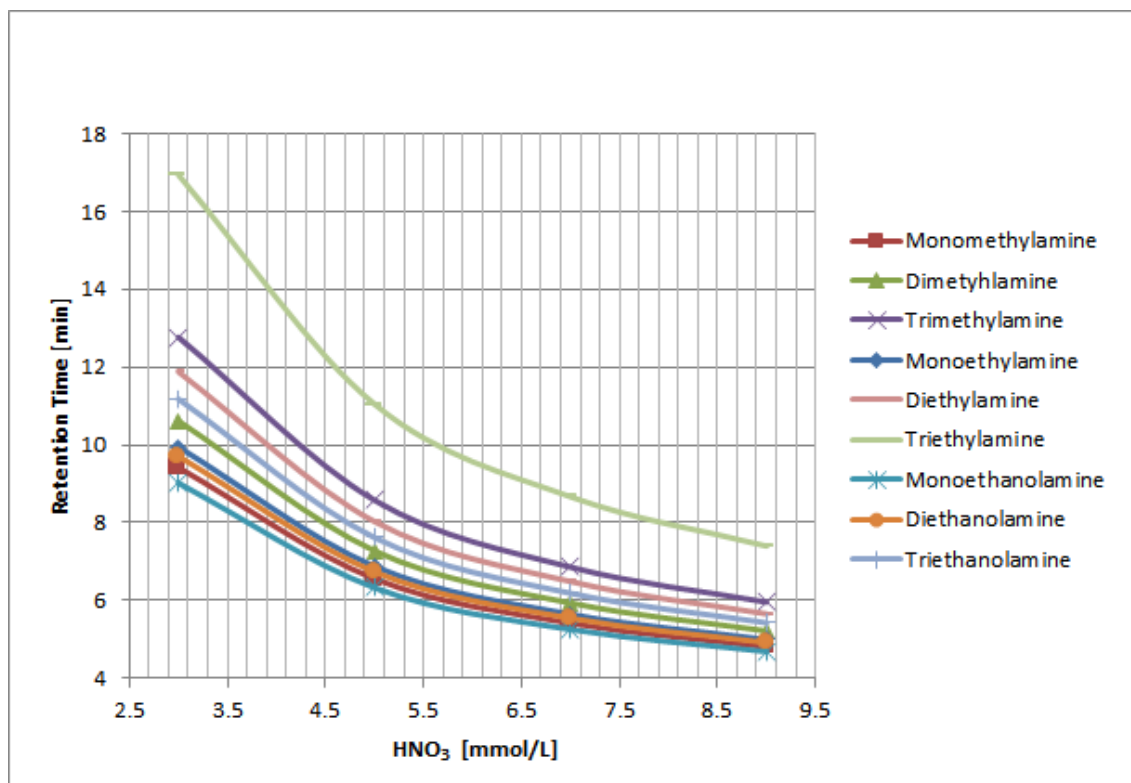

Figure 3 Nitric acid variations - Amines

The retention times of the amines continuously decrease with increasing eluent strength.

Variation of the organic modifier acetone

Column

Metrosep C Supp 1 - 250/4.0

Sample preparation:

-

Detection:

Conductivity

Suppression:

Sequential suppression with MSM-HC C and MCS

Temperature:

40 °C

Loop:

20 µL

Flow rate:

1.0 mL/min

Eluent:

Respectively 0, 5, 10, 15, 20% acetone by volume, each with 5.0 mmol/L of nitric acid and 50 µg/L of rubidium

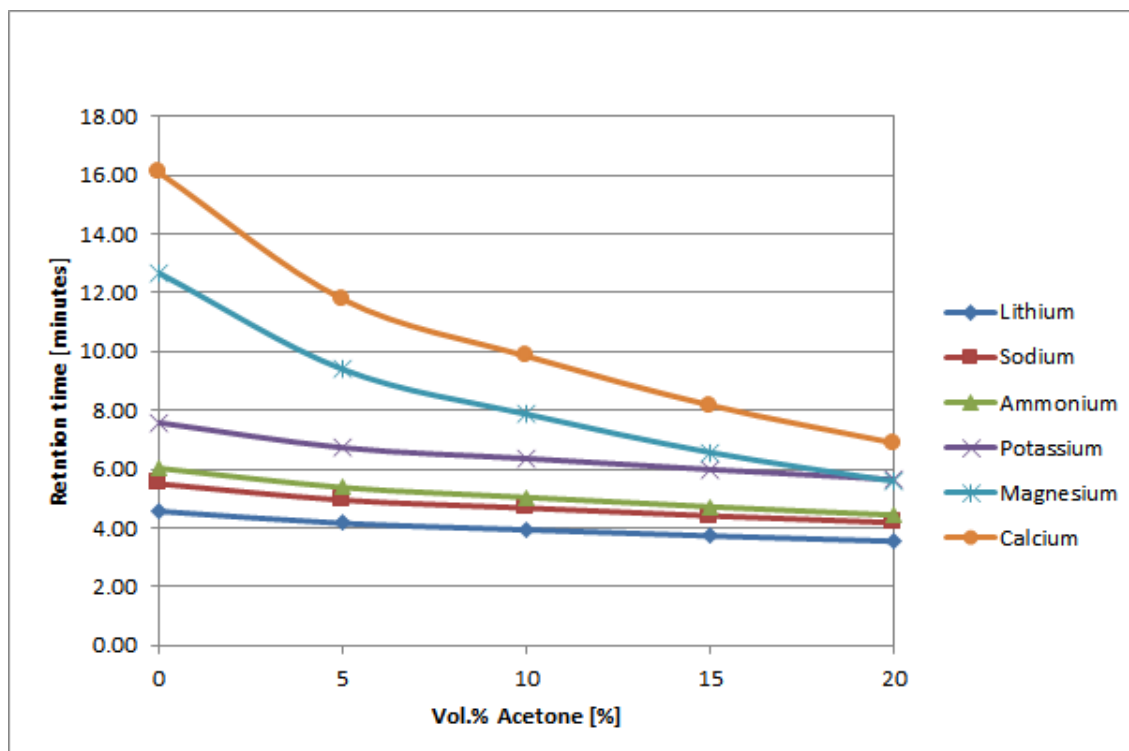

Figure 4 Acetone variations – Standard cations

Polyvalent cations such as magnesium and calcium are disproportionately accelerated to the monovalent cations with increasing percentages of acetone.

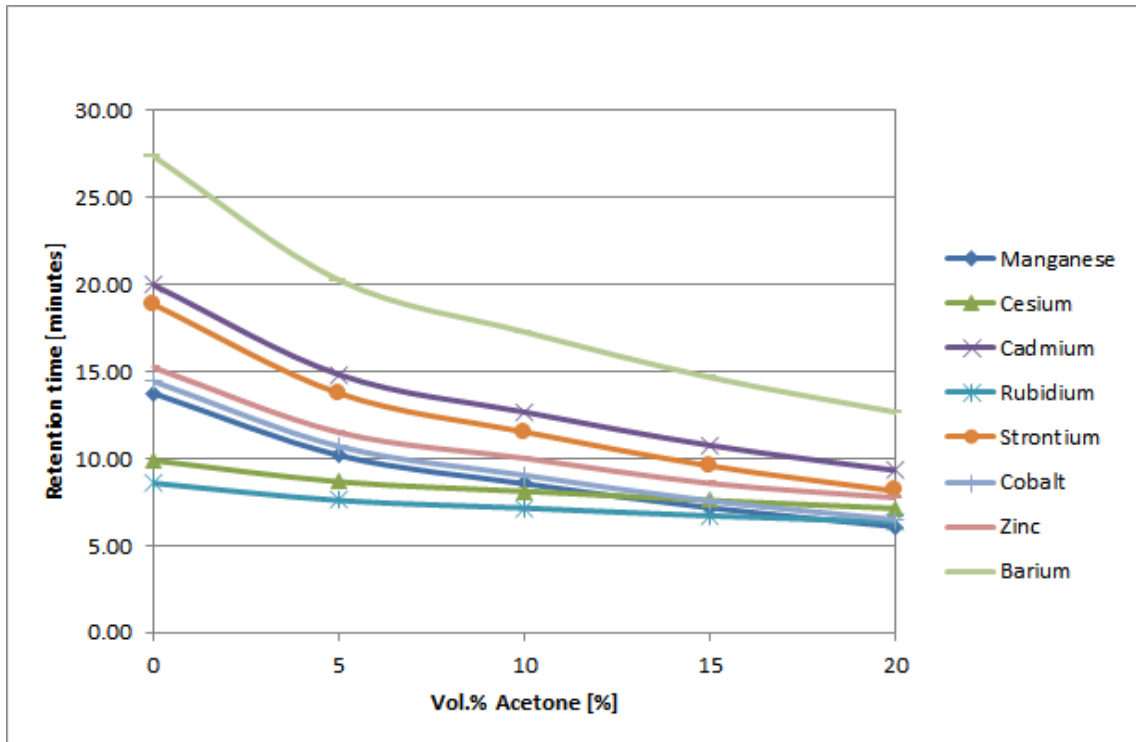

Figure 5 Acetone variations – Transition metals

Transition metals are also disproportionately accelerated by increasing the percentage of acetone.

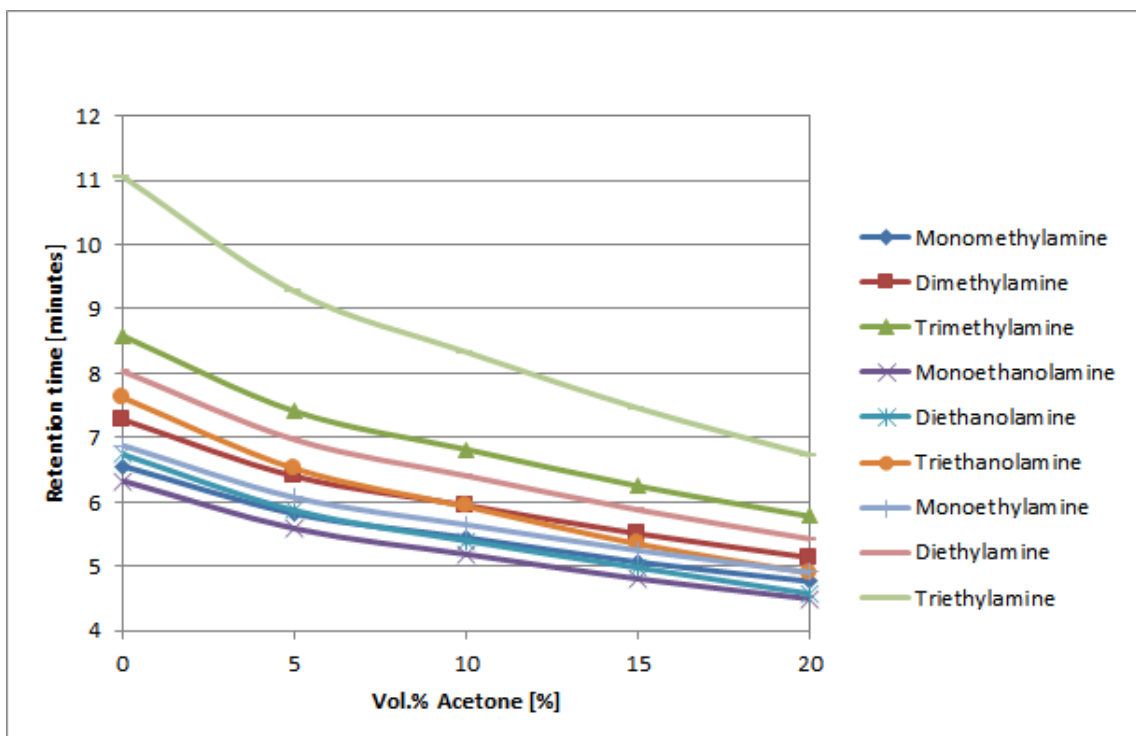

Figure 6 Acetone variations - Amines

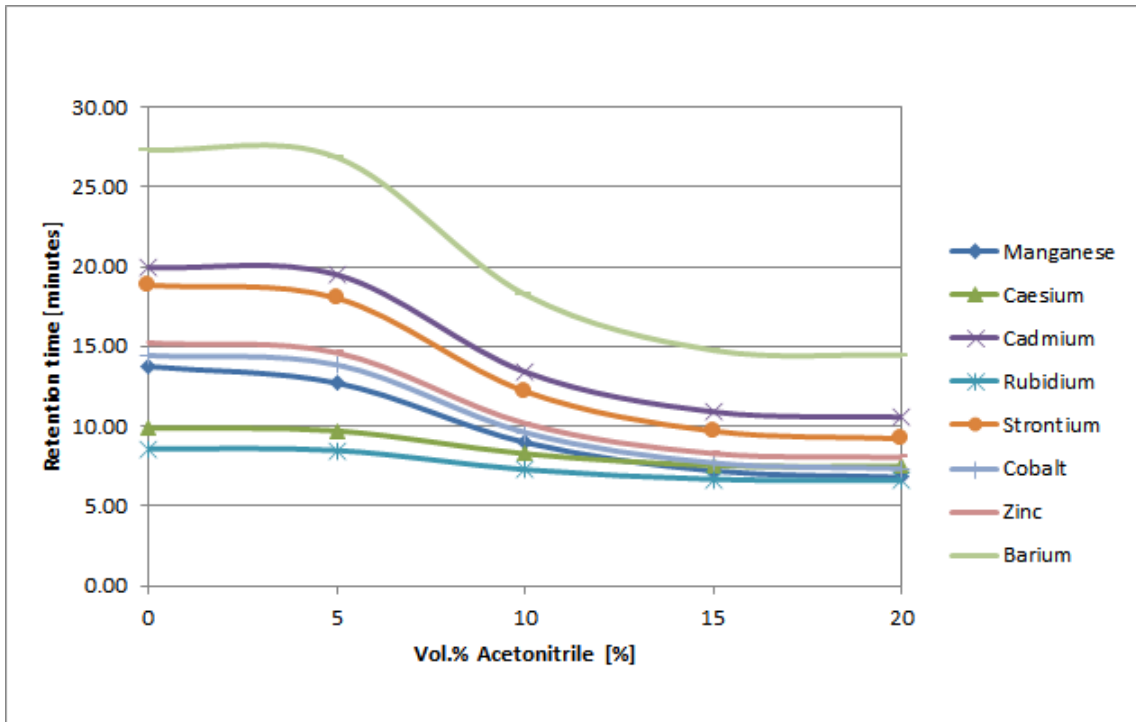

Figure 8 Acetonitrile variations – Transition metals

Transition metals are also disproportionately accelerated with increasing proportions of acetonitrile. There is hardly any difference noticeable between 15 and 20%.

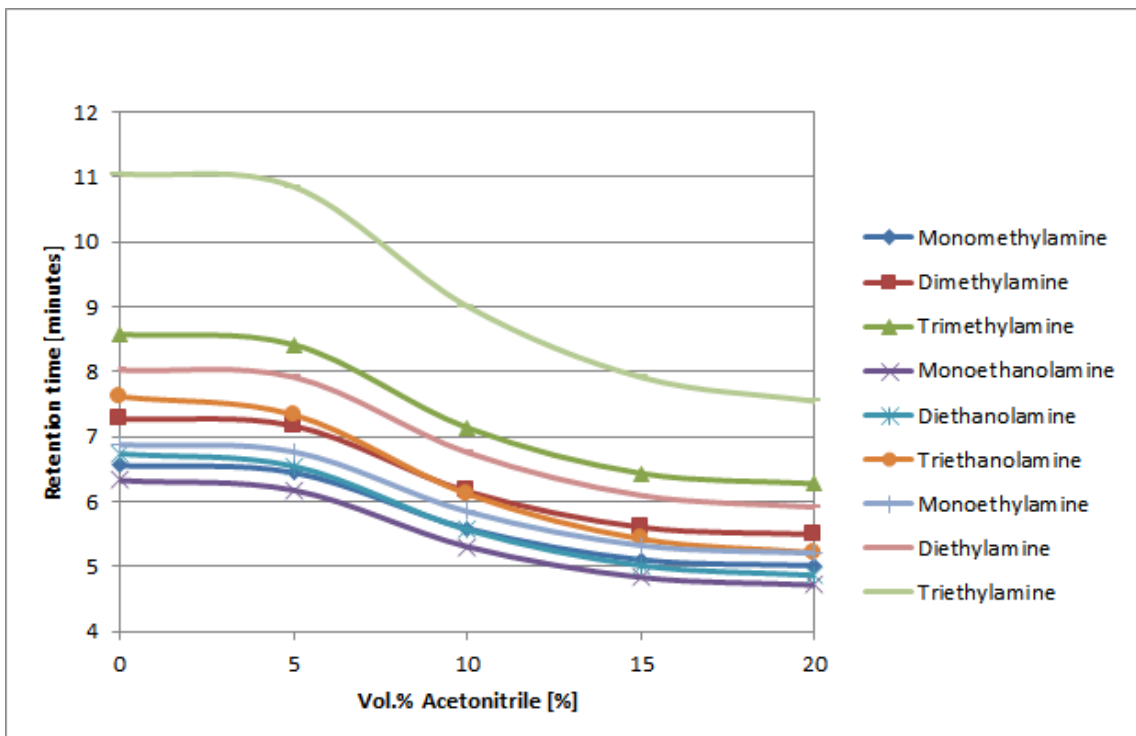

Figure 9 Acetonitrile variations – Amines



The retention times of the amines continuously decrease with increasing acetonitrile concentration. Triethanolamine, dimethylamine as well as monomethylamine and diethanolamine, once again, change the retention order.

5.5 Determining concentrations of trace metals in a magnesium sports drink

<i>Column</i>	Metrosep C Supp 1 - 250/4.0
<i>Sample preparation:</i>	Dissolve 1 4.5 g bag in 1 L of ultrapure water and degassed for 5 minutes at 30 mbar. Then dilute manually to a ratio of 1:50.
<i>Detection:</i>	Conductivity
<i>Suppression:</i>	Sequential suppression with MSM-HC C and MCS
<i>Temperature:</i>	40 °C
<i>Loop:</i>	20 µL
<i>Flow rate:</i>	1.0 mL/min
<i>Eluent:</i>	5.0 mmol/L of nitric acid and 200 µg/L of rubidium

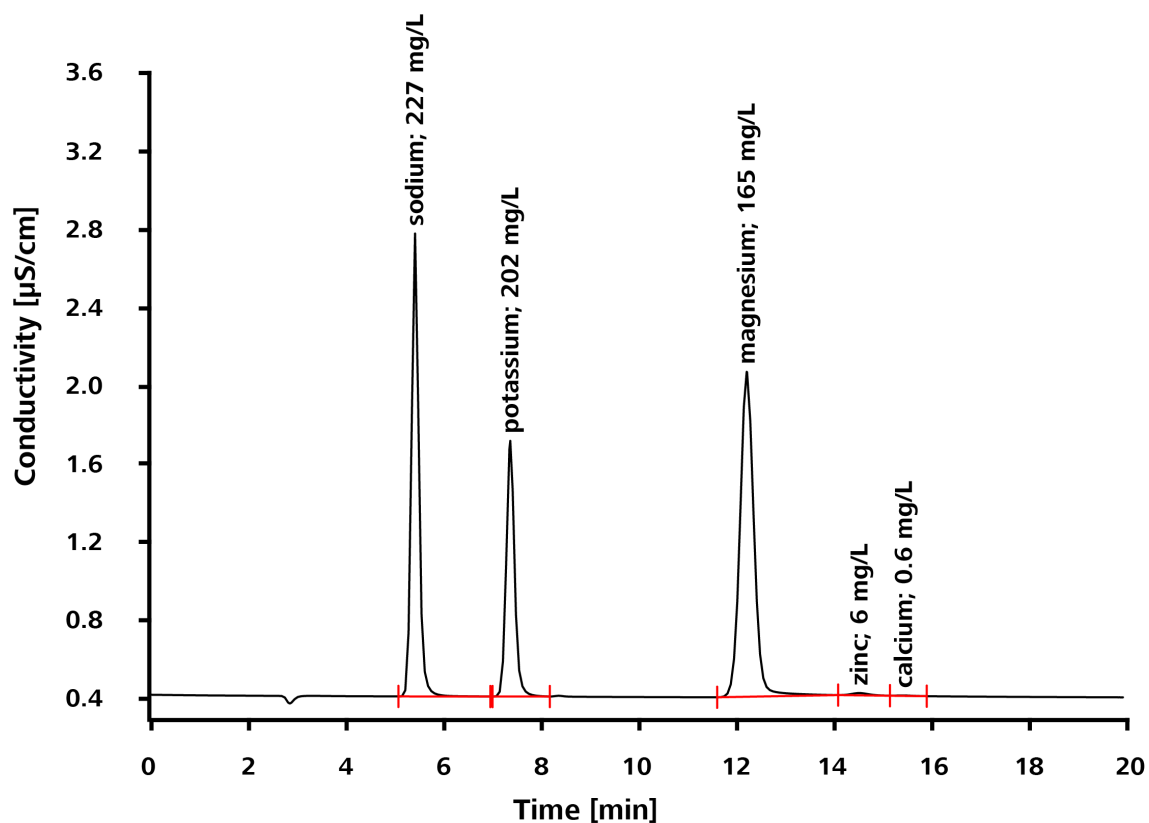

5.6 Ultratrace analysis of lithium and sodium in nuclear power plant samples with a monoethanolamine matrix

<i>Column</i>	Metrosep C Supp 1 - 250/4.0
<i>Sample preparation:</i>	Inline matrix elimination and inline preconcentration with Metrosep C PCC 1 HC/4.0 (6.1010.310)
<i>Detection:</i>	Conductivity
<i>Suppression:</i>	Sequential suppression with MSM-HC C and MCS
<i>Temperature:</i>	40 °C
<i>Loop:</i>	2,000 μL
<i>Flow rate:</i>	1.0 mL/min
<i>Eluent:</i>	4.0 mmol/L of nitric acid and 50 $\mu\text{g}/\text{L}$ of rubidium

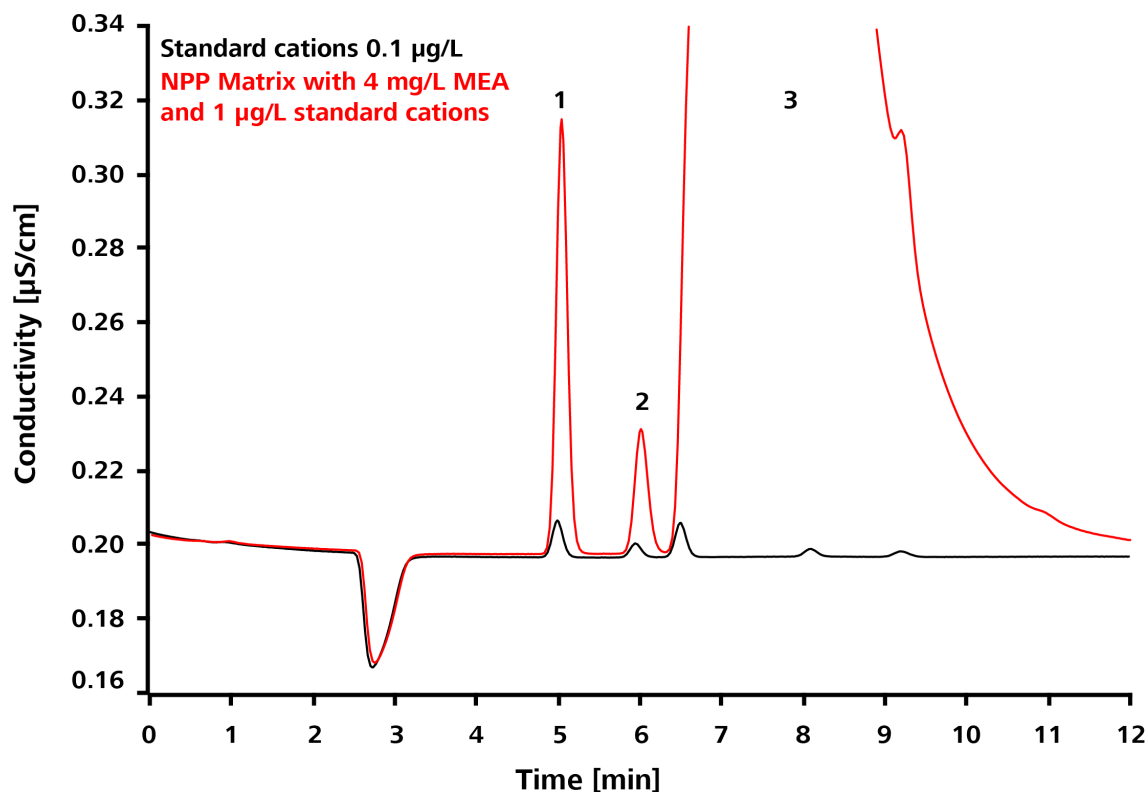

	Metrosep C Supp 1 - 250/4.0	Standard cations (black)	Nuclear power plant (NPP) matrix (red)
1	Lithium	0.1 µg/L	1.0 µg/L
2	Sodium	0.1 µg/L	1.0 µg/L
3	Monoethanolamine (MEA)	0 mg/L	4 mg/L

5.7 Trace analysis of standard cations and manganese, zinc and monoethanolamine

<i>Column</i>	Metrosep C Supp 1 - 250/4.0
<i>Sample preparation:</i>	Inline matrix elimination and inline preconcentration with Metrosep C PCC 1 HC/4.0 (6.1010.310)
<i>Detection:</i>	Conductivity
<i>Suppression:</i>	Sequential suppression with MSM-HC C and MCS
<i>Temperature:</i>	40 °C
<i>Loop:</i>	1000 µL

Flow rate: 1.0 mL/min

Eluent: 4.0 mmol/L of nitric acid and 50 µg/L of rubidium

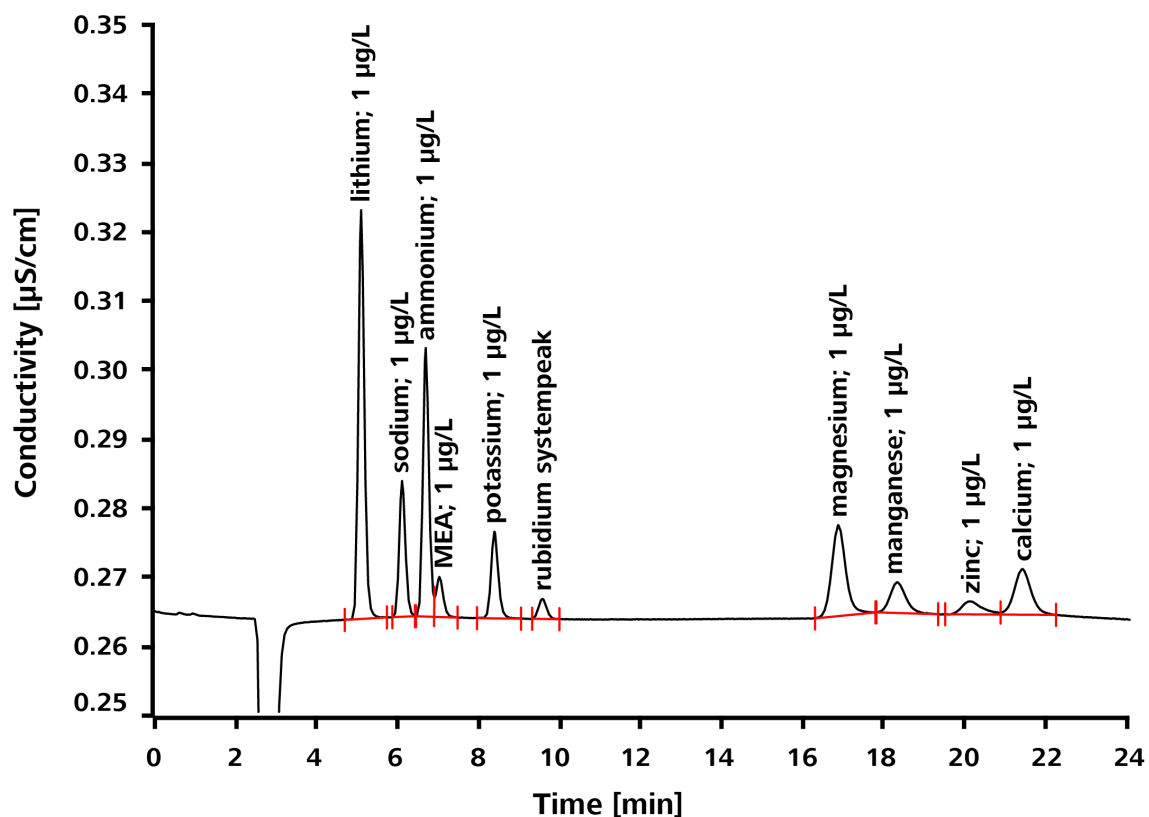

5.8 Determination of aliphatic amines

Column: Metrosep C Supp 1 - 250/4.0

Sample preparation: -

Detection: Conductivity

Suppression: Sequential suppression with MSM-HC C and MCS

Temperature: 40 °C

Loop: 20 µL

Flow rate: 0.4 mL/min

Eluent: 2.5 mmol/L of nitric acid, 50 µg/L of rubidium, 7.5% (v/v) acetonitrile

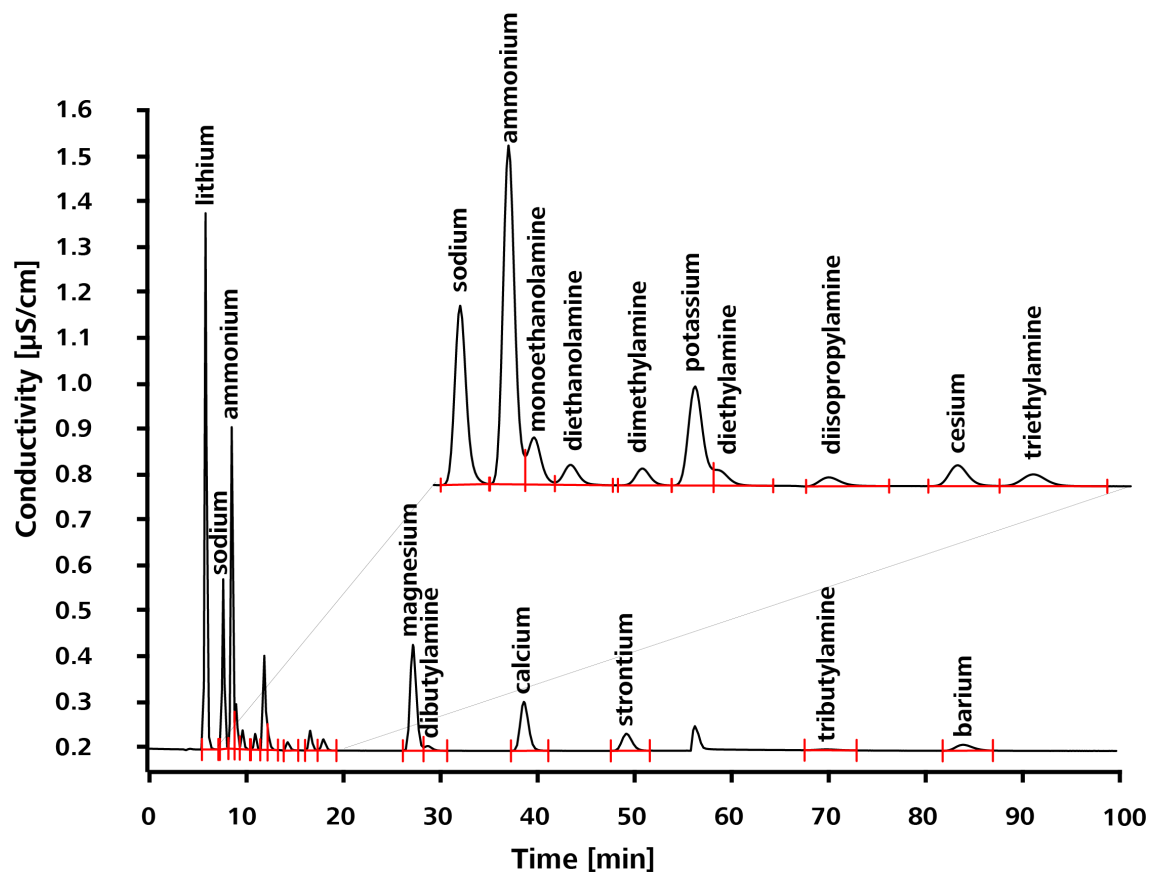

5.9 Analysis of tap water

Column	Metrosep C Supp 1 - 250/4.0
Sample preparation:	-
Detection:	Conductivity
Suppression:	Sequential suppression with MSM-HC C and MCS
Temperature:	40 °C
Loop:	20 µL
Flow rate:	1.0 mL/min
Eluent:	5.0 mmol/L of nitric acid and 50 µg/L of rubidium

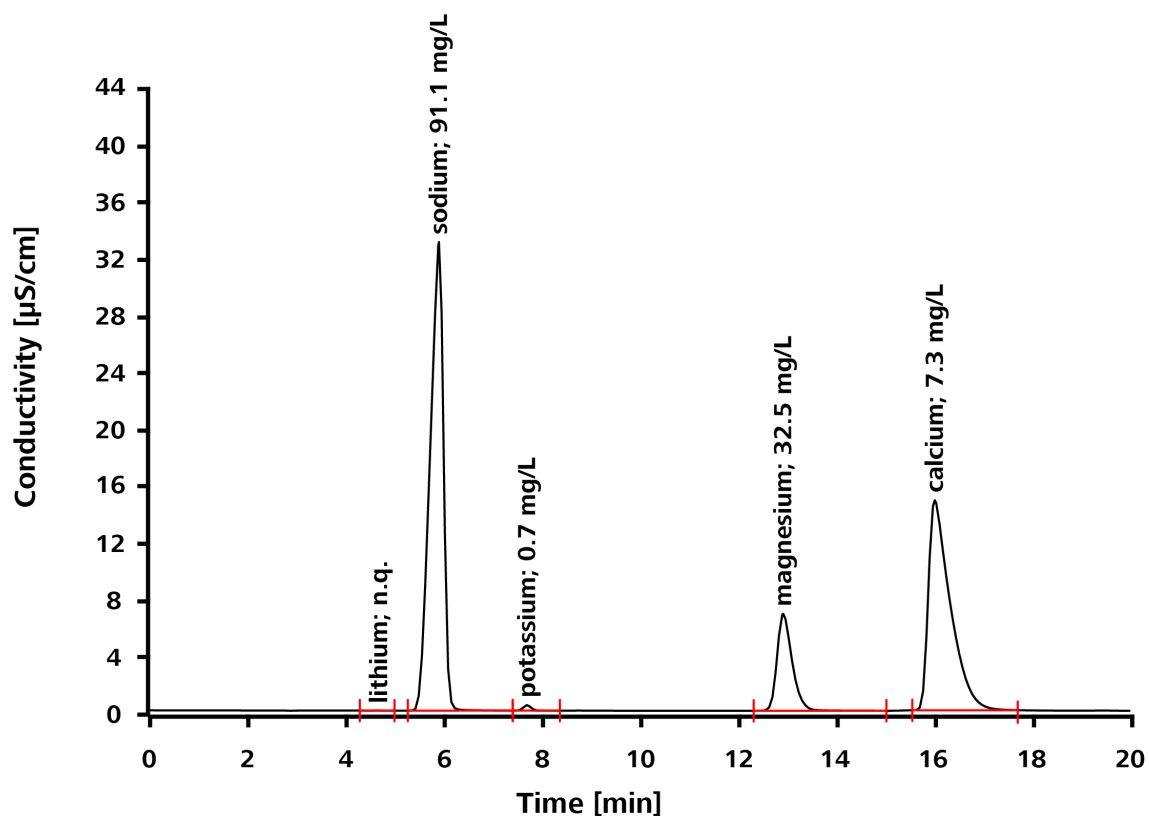

5.10 Determination of biogenic amines in addition to the standard cations

Column Metrosep C Supp 1 - 250/4.0

Sample preparation: -

Detection: Conductivity

Suppression: Sequential suppression with MSM-HC C and MCS

Temperature: 40 °C

Loop: 20 μL

Flow rate: 1.0 mL/min

Eluent: Dose-in gradient:

Eluent A: 5.0 mmol/L of nitric acid and 50 $\mu\text{g/L}$ of rubidium

Eluent B: 25.0 mmol/L of nitric acid and 50 $\mu\text{g/L}$ of rubidium

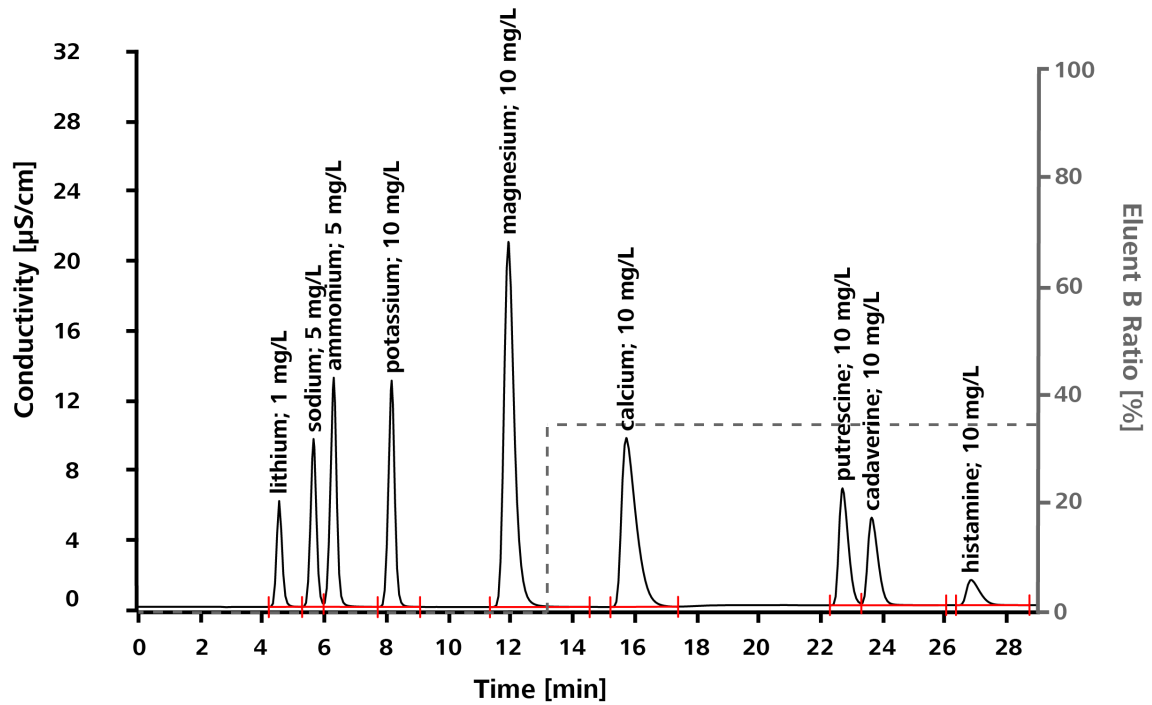

The retention time of the biogenic amines can be decreased dramatically using the dose-in gradient. Under standard conditions, using 5 mmol/L of nitric acid and 50 µg/L of rubidium, putrescine elutes at 45 minutes, cadaverine at 51 minutes and histamine at 71 minutes.

5.11 Determination of choline in baby food

<i>Column</i>	Metrosep C Supp 1 - 250/4.0
<i>Sample preparation:</i>	Analogous to standard AOAC 2012.20
<i>Detection:</i>	Conductivity
<i>Suppression:</i>	Sequential suppression with MSM-HC C and MCS
<i>Temperature:</i>	40 °C
<i>Loop:</i>	20 µL
<i>Flow rate:</i>	1.0 mL/min
<i>Eluent:</i>	4.0 mmol/L of nitric acid and 50 µg/L of rubidium

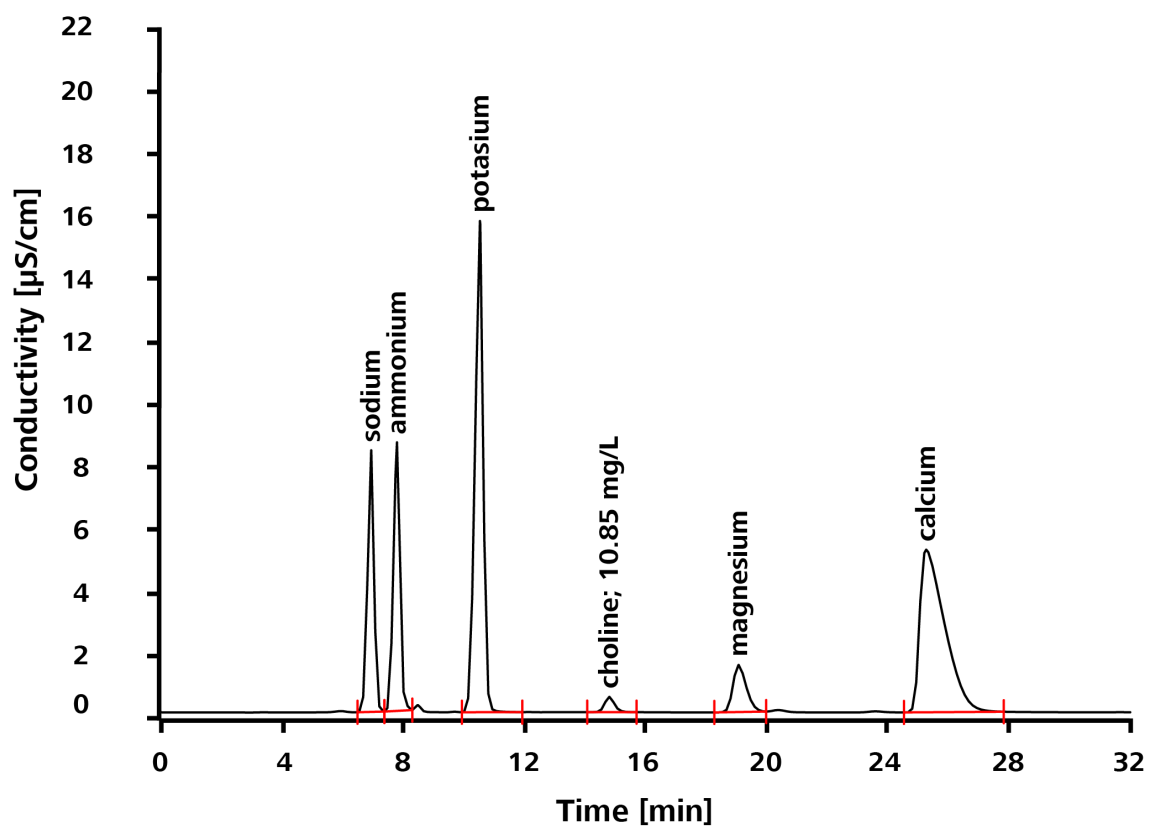

Calculated on the sample weight, the choline content amounts to 82 mg/100 g of powdered milk.

6 Troubleshooting

6.1 Regeneration



CAUTION

Do not regenerate the column as a preventive measure!

Each regeneration process causes stress on the separation column and reduces its service life see "Regenerating separation columns", page 5.

Problem

- The backpressure increases.
- Double peaks occur.
- Tailing effects occur.
- The retention times become shorter.
- The resolution deteriorates.

Correction

Regenerating the separation column

Start by replacing the guard column if the above problems occur. Only regenerate the separation column as described below if this measure does not help.

1 Disconnecting the separation column from the IC system

- Disconnect the outlet of the separation column from the inlet of the suppressor or of the detector.
Collect the flow of liquid in a beaker.

2 Regenerating the separation column

The separation column has to be regenerated differently depending on the type of contamination:

Table 3 Organic contamination

	Rinse with	Direction	Duration [min]	Flow rate [mL/min]
1	Ultrapure water	Opposite flow direction	60	1

	Rinse with	Direction	Duration [min]	Flow rate [mL/min]
2	Acetonitrile-water mixture (30:70)	Opposite flow direction	60	1
3	Ultrapure water	Opposite flow direction	60	1

Table 4 Inorganic contamination

	Rinse with	Direction	Duration [min]	Flow rate [mL/min]
1	Standard eluent with 30% acetonitrile	Opposite flow direction	60	1

6.2 Decreasing resolution / peak shapes

Problem

The resolution of peaks deteriorates or peak shapes are asymmetrical.

Causes and prevention

Causes	Prevention/correction
The separation column has been overloaded	<p>The separation column can be overloaded by factors such as high salt content in the sample matrix.</p> <ul style="list-style-type: none"> ▪ Dilute the sample. ▪ Inject less sample.
There are dead volumes in the IC system	<ul style="list-style-type: none"> ▪ Check that all of the capillaries have a diameter of ≤ 0.25 mm (6.1831.010). If not, replace the larger capillaries. ▪ Check that all of capillaries have been installed correctly. The step-by-step installation process is shown in the IC Maintenance multimedia guide.

Causes	Prevention/correction
Particles in the sample	▪ Sample preparation, e.g. removing particles through inline ultrafiltration.

7 Literature

We recommend referring to the following literature for more detailed information:

- Cation suppressor brochure in the ion chromatography, 8.000.5163
- Column catalog, 8.000.5117
- Application Note CS-001 Reproducibility of standard cations with suppressed cation chromatography at 10 µg/L
- Application Note CS-002 Linearity of ammonium with suppressed cation chromatography
- Application Note CS-003 Determination of biogenic amines with suppressed conductivity detection applying a dose-in gradient
- Application Note CS-004 Determination of choline in baby milk powder
- Application Note CS-005 Determination of tetrabutylammonium in Atorvastatin calcium

Index

B

Baseline	
Condition	15

C

Column	
see "Separation column"	11
Conditioning	15

E

Eluent	7
Equilibration	15

F

Flow rate	2
-----------------	---

G

Guard column	
Installation	9
Rinse	10

I

IC column	
see "Separation column"	11
Installation	
Guard column	9
Separation column	11

O

Order number	1
--------------------	---

R

Rinse	
Guard column	10
Separation column	13

S

Separation column	
Installation	11
Rinse	13
Specification	1