







Metrohm AG  
CH-9100 Herisau  
Switzerland  
Phone +41 71 353 85 85  
Fax +41 71 353 89 01  
info@metrohm.com  
www.metrohm.com

# **Column manual**

**Metrosep Carb 2 (6.1090.XX0 /  
6.01090.XX0)**

**Manual**

Technische Dokumentation  
Metrohm AG  
CH-9100 Herisau  
techdoc@metrohm.com

This documentation is protected by copyright. All rights reserved.

This documentation has been prepared with great care. However, errors can never be entirely ruled out. Please send comments regarding possible errors to the address above.

# Table of contents

<b>1</b>	<b>General information</b>	<b>1</b>
1.1	Ordering information .....	1
1.2	Technical specifications .....	2
<b>2</b>	<b>Key aspects of working with separation columns</b>	<b>4</b>
<b>3</b>	<b>Eluent production</b>	<b>8</b>
3.1	Chemicals .....	8
3.2	Production of standard eluent .....	9
<b>4</b>	<b>Start-up</b>	<b>11</b>
4.1	Connecting and rinsing the guard column .....	12
4.2	Connecting the separation column .....	15
4.3	Conditioning .....	18
<b>5</b>	<b>Applications</b>	<b>20</b>
5.1	Standard chromatogram .....	20
5.2	Effects of modifying the flow rate .....	22
5.3	Effects of temperature .....	24
5.4	Variation of the eluent .....	26
5.5	Determination of primary sugar content in apple juice ..	29
5.6	Air particle analysis of tracers such as levoglucosan from wood fires .....	30
5.7	Cosmetic product analysis .....	31
5.8	Determination of lactose in lactose-free milk .....	32
5.9	Multi-component analysis .....	33
5.10	Yogurt .....	34
5.11	Sea water analysis with UV detection .....	35
5.12	Determination of chromium species .....	36
5.13	Use of Metrosep CO <sub>3</sub> <sup>2-</sup> Trap 1 – 100/4.0 .....	37
5.14	Use of Metrosep BO <sub>3</sub> <sup>3-</sup> Trap 1 – 100/4.0 .....	38
<b>6</b>	<b>Troubleshooting</b>	<b>39</b>
6.1	Regeneration .....	39
6.2	Decreasing resolution / peak shapes .....	40



6.3	Unstable retention times .....	41
6.4	Unknown peaks .....	42
6.5	Increasing backpressure .....	42
<b>7</b>	<b>Literature</b>	<b>43</b>
	<b>Index</b>	<b>44</b>

# 1 General information

The Metrosep Carb 2 separation column is intended specifically for the determination of carbohydrates using alkaline eluents and pulsed amperometric detection. This column can be used to analyze sugar alcohols, anhydrosugars, monosaccharides and disaccharides.

Metrosep Carb 2 can also be used to determine nitrite, bromide, and nitrate in seawater.

## 1.1 Ordering information

*Table 1 4-mm columns*

<b>Order number</b>	<b>Designation</b>
6.1090.410	Metrosep Carb 2 - 100/4.0
6.1090.420	Metrosep Carb 2 - 150/4.0
6.1090.430	Metrosep Carb 2 - 250/4.0

*Table 2 2-mm columns*

<b>Order number</b>	<b>Designation</b>
6.01090.210	Metrosep Carb 2 - 100/2.0
6.01090.220	Metrosep Carb 2 - 150/2.0
6.01090.230	Metrosep Carb 2 - 250/2.0

*Table 3 Guard columns*

<b>Order number</b>	<b>Designation</b>
6.1090.500	Metrosep Carb 2 Guard/4.0
6.1090.510	Metrosep Carb 2 S-Guard/4.0
6.01090.600	Metrosep Carb 2 Guard/2.0
6.01090.610	Metrosep Carb 2 S-Guard/2.0



## 1.2 Technical specifications

*Column material* Polystyrene/divinylbenzene copolymer with quaternary ammonium groups

*Particle size* 5 µm

*Dimensions*

Order number	Dimensions
6.1090.410	100 x 4.0 mm
6.1090.420	150 x 4.0 mm
6.1090.430	250 x 4.0 mm
6.01090.210	100 x 2.0 mm
6.01090.220	150 x 2.0 mm
6.01090.230	250 x 2.0 mm

*pH range* 0 to 14

*Temperature range* 20 to 60 °C

*Recommended standard temperature* 30 °C

*Maximum pressure* 20 MPa (200 bar)

*Flow rate*

Order number	Recommended flow rate	Maximum flow rate
6.1090.410	0.8 mL/min	1.6 mL/min
6.1090.420	0.8 mL/min	1.2 mL/min
6.1090.430	0.5 mL/min	0.8 mL/min
6.01090.210	0.2 mL/min	0.7 mL/min
6.01090.220	0.13 mL/min	0.45 mL/min
6.01090.230	0.13 mL/min	0.30 mL/min

*Standard eluent* 100 mmol/L of sodium hydroxide + 10 mmol/L of sodium acetate

*Permitted organic additives*

*in the eluent* 0 to 50% acetonitrile or methanol

*in the sample matrix* 0 to 100% acetone, acetonitrile or methanol

*Preparation* 1. Use a flow gradient to set the column to the standard flow within 5 minutes.  
2. Rinse the column with the desired eluent for 2 h at 30 °C.

*Storage* Store the column in standard eluent at ambient temperature.

*Typical pressure* For columns with a guard column under standard conditions

Order number	Typical pressure
6.1090.410	9 MPa (±2 MPa)
6.1090.420	9 MPa (±2 MPa)
6.1090.430	10 MPa (±2 MPa)
6.01090.210	5.5 MPa (±2 MPa)
6.01090.220	5.5 MPa (±2 MPa)
6.01090.230	8.0 MPa (±2 MPa)

*Column body* Smart column with a chip, called iColumn, made of PEEK

*Application* Determination of carbohydrates such as monosaccharides and disaccharides, sugar alcohols, anhydrosugars, amino sugars, sugar substitutes and oligosaccharides

*Options* Can be used with the following trap columns:

- Metrosep BO<sub>3</sub><sup>3-</sup> Trap 1 - 100/4.0 (6.1015.200)
- Metrosep CO<sub>3</sub><sup>2-</sup> Trap 1 - 100/4.0 (6.1015.300)

## 2 Key aspects of working with separation columns

*Storage* Once the backpressure in your ion chromatograph has dissipated, remove the column at ambient temperature. Seal the column at both ends using the original stoppers (6.2744.060). Store it in the standard eluent at ambient temperature.

*Bacterial growth* Bacterial growth significantly affects chromatography and ruins separation columns. A vast array of problems in chromatography are caused by the growth of algae, bacteria and fungi.

In order to prevent bacterial growth, always use fresh eluents, rinsing solutions and regeneration solutions. Do not use any solutions that have not been used for a prolonged period. We recommend cleaning all vessels as follows before filling them:

1. Thoroughly rinse with ultrapure, UV-treated water (> 18.2 MΩ).
2. Swirl a methanol-water or acetone-water mixture around in the vessel.
3. Rinse with water once again.

If you notice the growth of bacteria or algae despite these precautionary measures, add 5% methanol or acetonitrile to the eluent.

*Chemical quality* All chemicals must have at least a quality of p.a. or puriss. Standard solutions must be intended specifically for ion chromatography.

*Chemical stress* Even though specifications may indicate that separation phases do tolerate a pH of 0 to 14, this does not mean that they are chemically inert. Separation columns last longest when subjected to constant chemical conditions. Never allow a column to dry out and ensure the column is sealed well at all times.

*CO<sub>2</sub>* Carbon dioxide from the air affects sodium hydroxide eluents. The eluent develops a strong elution strength over time. In order to prevent this, always outfit the eluent bottle with CO<sub>2</sub> adsorber material (such as soda lime).

*Eluent bottles* The eluents are usually placed directly on the IC system in special eluent bottles. The bottles must feature an adsorber tube in order to prevent humidity and carbon dioxide from getting into the eluent. Normally, the adsorber tube is filled with a molecular sieve or—for sodium hydroxide and carbonate eluents—with soda lime (a weak CO<sub>2</sub> adsorber).

*Degassing the eluent* In order to prevent bubbles from forming, we recommend degassing the produced eluent before using it in your IC system. To degas the eluent, create a vacuum for approximately ten minutes using a water-jet pump or an oil pump. Use an ultrasonic bath or work with an eluent degasser.

*Filter* Problems that occur in IC systems are usually related to particles. These particles can be introduced from the following sources:

- Bacterial growth
- Unfiltered eluents
- The sample
- The rinsing solution and/or regeneration solution

Minimize this risk by using an aspiration filter (6.2821.090), an inline filter (6.2821.120) and a guard column. The filters are part of the basic equipment for Metrohm ion chromatographs and are included in the scope of delivery. We also recommend changing the filters regularly.

*Filtering the eluent* All eluents have to be microfiltered (0.45 µm) immediately before use.

*Particles* All solutions, samples, regeneration solutions, water and eluents have to be free of particles. Particles clog separation columns over time (column pressure increases). Be especially conscious of ensuring that there are no particles present when producing eluents. The eluent continuously flows through the column at a rate of 500 to 1000 mL per workday compared to about 0.5 mL of the sample solution. Filter or dialyze your sample automatically with one of the Metrohm Inline Sample Preparation techniques (MISP).

*Sample preparation cartridges* Sample preparation cartridges are used to prepare critical samples that cannot be injected directly into the separation column. They perform tasks such as removing organic contaminants or neutralizing heavily alkaline or acidic samples. Sample preparation cartridges are consumables that generally cannot be regenerated. Sample preparation cartridges do not replace the guard columns, which should always be used with each separation column. As an alternative to sample preparation cartridges, Metrohm Inline Sample Preparation techniques (MISP) can be used, such as for neutralizing alkaline samples.

*Pulsation absorber* We recommend using a pulsation absorber (6.2620.150). Polymethacrylate columns and polyvinyl alcohol columns in particular must be protected from the brief pressure surges that inevitably occur when switching the valves.

*Mechanical stress* Mechanical loads on the column should be avoided. For example, the column impacting a hard surface can cause a break or gap in the column packing (separation phase material); this affects the chromatography results. The column would be irreparably damaged as a result.





## 3 Eluent production

We recommend choosing a high level of purity for chemicals for both standard production and eluent production.

### 3.1 Chemicals



#### CAUTION

---

Do not produce sodium hydroxide eluents from sodium hydroxide pellets. The outer layer of the pellets contains carbonate, which will affect the chromatography!



#### CAUTION

---

Sodium hydroxide solutions easily absorb CO<sub>2</sub> from the air. In order to minimize contact with the air, we recommend placing an aliquot in a second vessel and opening the stock solution as few times as possible.

#### *Recommended chemicals*

- Sodium hydroxide solution  $\geq 30\%$  in H<sub>2</sub>O, TraceSelect®  
Sigma Aldrich order number: 13171-250ML
- Sodium hydroxide solution 50 to 52% in H<sub>2</sub>O  
Sigma Aldrich order number: 72064-500ML
- Sodium acetate  $\geq 99.0\%$ , 82.03 g/mol, anhydrous, ReagentPlus®  
Sigma Aldrich order number: S8750-250G
- Deionized ultrapure water of type I (see ASTM D1193)  
Resistance  $> 18 \text{ M}\Omega\cdot\text{cm}$  (25 °C)  
TOC  $< 10 \mu\text{g/L}$

## 3.2 Production of standard eluent

For eluent production, we recommend using a polypropylene eluent bottle (6.1608.120) with accompanying cap (6.1602.200). This prevents contamination from borate caused by borosilicate glass. In addition, ensure that the eluent comes in contact with the air as little as possible.

Proceed as follows to produce 1 L of standard eluent with 100 mmol/L of sodium hydroxide and 10 mmol/L of sodium acetate:

### Producing 1 L of standard eluent

#### Required accessories

- Eluent bottle (6.1608.120)
- Cap (6.1602.200) equipped with CO<sub>2</sub> adsorber
- Ultrapure water
- Sodium hydroxide solution 50 to 52% in H<sub>2</sub>O
- Sodium acetate ≥ 99.0%, 82.03 g/mol, anhydrous, ReagentPlus®

- 1** Degas 990 mL of ultrapure water for at least ten minutes before adding the reagent.
- 2** While stirring gently, add 5.3 mL of 50 percent sodium hydroxide solution and 0.82 g of sodium acetate.
- 3** Then connect the eluent to the chromatography system.

Applying a layer of argon or nitrogen over the eluent as a protective gas protects the eluent from CO<sub>2</sub> contamination.

A background current of < 500 nA is to be expected with this eluent (100 mmol/L of sodium hydroxide and 10 mmol/L of sodium acetate) and the standard conditions for the amperometric detector (PAD mode, working electrode: Au, 3 mm, reference electrode: Pd; work potential: 50 mV). The noise level is typically less than 3 nA.

Table 4 shows the concentrations in mol/L and g/L as well as the corresponding density per given mass fraction of sodium hydroxide in percentage by weight.

Table 4

NaOH in [wt%]	4.0	10.0	20.0	30.0	40.0	50.0
NaOH in [mol/L]	1.04	2.77	6.09	9.95	14.3	19.05
NaOH in [g/L]	41.7	110.9	243.8	398.3	572.0	762.2
Density [g/cm <sup>3</sup> ]	1.043	1.109	1.219	1.328	1.430	1.524



Table 5 shows the necessary volume (mL) and necessary mass (g) for producing 1 L of sodium hydroxide eluent from a 30 percent and 50 percent sodium hydroxide stock solution respectively.

Table 5

Eluent concentration [mmol/L]	30% (w/w) NaOH solution		50% (w/w) NaOH solution	
	[mL]	[g]	[mL]	[g]
5	0.5	0.7	0.3	0.4
10	1.0	1.3	0.5	0.8
20	2.0	2.7	1.1	1.6
30	3.0	4.0	1.6	2.4
40	4.0	5.3	2.1	3.2
50	5.0	6.7	2.6	4.0
60	6.0	8.0	3.2	4.8
70	7.0	9.3	3.7	5.6
80	8.0	10.7	4.2	6.4
90	9.0	12.0	4.7	7.2
100	10.0	13.4	5.3	8.0
200	20.1	26.7	10.5	16.0
300	30.2	40.0	15.8	24.0
400	40.2	53.4	21.0	32.0

The use of organic additives in the eluent results in increased noise in the amperometric detector. The percentage of the organic solvent has to be determined based on the application.



## 4 Start-up



### NOTE

To optimize chromatography, the systems that are used with the Metrosep Carb 2 - XXX/2.0 have to be adjusted before use.

Two capillaries must be replaced in the following way to decrease dead volume:

- Column inlet capillary: Replace the column inlet capillary by a 1.2-m long part of the PEEK capillary 0.18 mm inner diameter / 2 m (6.01806.000).
- Column outlet capillary: Replace the column outlet capillary by an approx. 40-cm long part of the PEEK capillary 0.18 mm inner diameter / 2 m (6.01806.000).

Connect the column outlet to the amperometric measuring cell inlet. The preheating capillary in the detector is not used. The capillary may also be shorter depending on where the detector is located. The shorter the capillary, the smaller the dead volume and the better the peak shape.

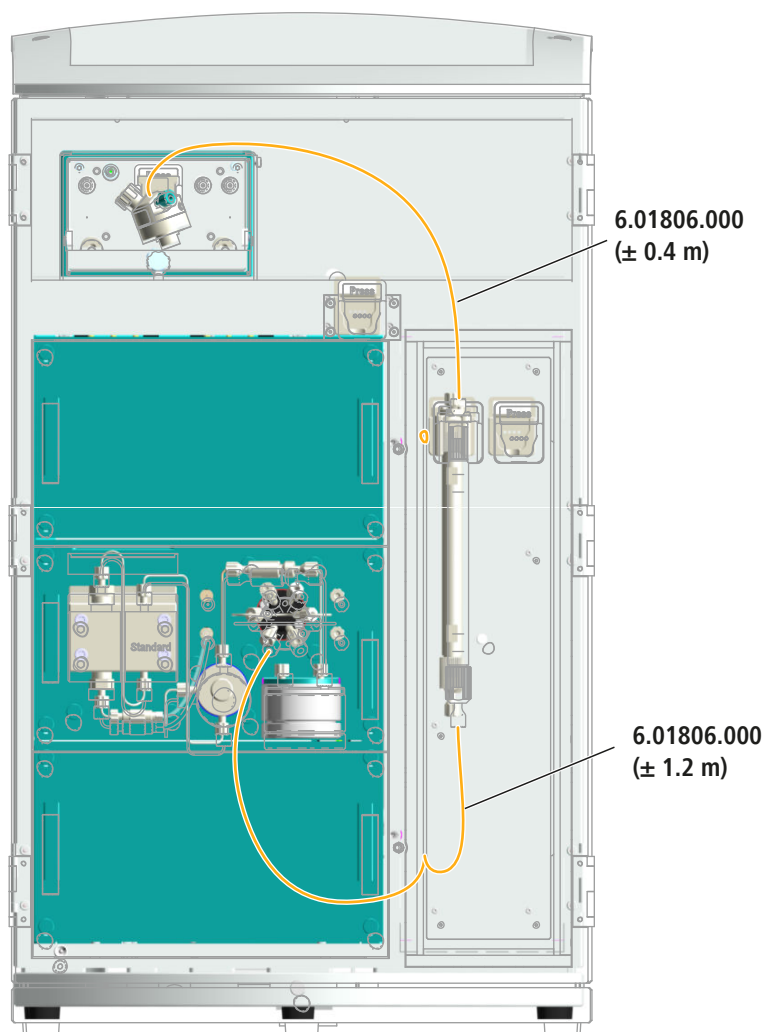

## 4.1 Connecting and rinsing the guard column

Guard columns protect separation columns and significantly increase their service life. The guard columns available from Metrohm are either actual guard columns or guard column cartridges used together with a cartridge holder. The process of installing a guard column cartridge into the corresponding holder is described in the guard column leaflet.



### NOTE

Metrohm recommends always working with guard columns. They protect the separation columns and can be replaced regularly as needed.

**NOTE**

Information regarding which guard column is suitable for your separation column can be found in the **Metrohm Column Program** (which is available from your Metrohm representative), the leaflet provided along with your separation column or the product information about the separation column at <http://www.metrohm.com> (Ion Chromatography product area), or it can be obtained directly from your representative.

**CAUTION**

New guard columns are filled with a solution and sealed with stoppers or caps on both sides.

Before inserting the guard column, ensure that this solution can be mixed with the eluent being used (follow the information provided by the manufacturer).

**NOTE**

The guard column may not be connected until after the instrument has already been put into operation once. The guard column and the separation column have to be replaced by a coupling (6.2744.040) until then.

*Accessories*

For this step, you need the following accessories:

- Guard column (suitable for separation column)

### Connecting the guard column

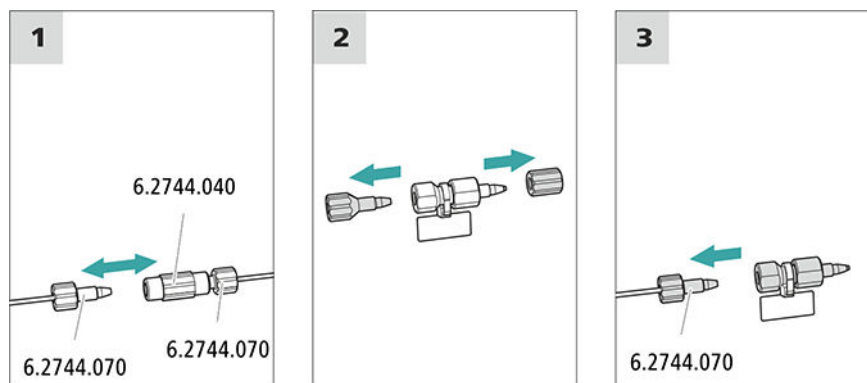

#### 1 Removing the coupling

Remove the coupling (6.2744.040) installed between the column inlet capillary and the column outlet capillary for the initial start-up.

#### 2 Preparing the guard column

- Remove the stopper and the sealing cap from the guard column.

#### 3 Connecting the guard column



#### CAUTION

When inserting the guard column, ensure that it is inserted correctly based on the marked flow direction (if specified).

- Fasten the inlet of the guard column to the column inlet capillary using a short pressure screw (6.2744.070).
- If the guard column is connected to the separation column using a connection capillary, fasten this connection capillary to the guard column outlet with a pressure screw.

### Rinsing the guard column

#### 1 Rinsing the guard column

- Place a beaker under the guard column's outlet.
- Start manual control in MagIC Net and select the high-pressure pump: **Manual ► Manual control ► Pump**
  - Flow: in accordance with column leaflet**
  - On**
- Rinse the guard column with eluent for approx. 5 minutes.

- Stop the high-pressure pump in the manual control in MagIC Net again: **Off**.

## 4.2 Connecting the separation column

The smart separation column (iColumn) is the heart of ion chromatographic analysis. It separates the different components according to their interactions with the column. Metrohm separation columns are equipped with a chip where their technical specifications and history (start-up, operating hours, injections etc) are stored.



### NOTE

Information regarding which separation column is suitable for your application can be found in the **Metrohm Column Program**, the product information for the separation column or it can be obtained through your representative.

You can find product information for your separation column at <http://www.metrohm.com> in the Ion Chromatography product area.

A test chromatogram and a leaflet accompanies every column. Detailed information on special IC applications can be found in the corresponding "**Application Bulletins**" or "**Application Notes**". You can find these online at <http://www.metrohm.com> in the Applications area or request them from your responsible Metrohm representative free of charge.



### CAUTION

New separation columns are filled with a solution and sealed with stoppers on both sides. Before inserting the column, ensure that this solution can be mixed with the eluent being used (follow the information provided by the manufacturer).



### NOTE

Connect the separation column only after the initial start-up of the instrument. Until that point, insert a coupling (6.2744.040) instead of the guard column and separation column.

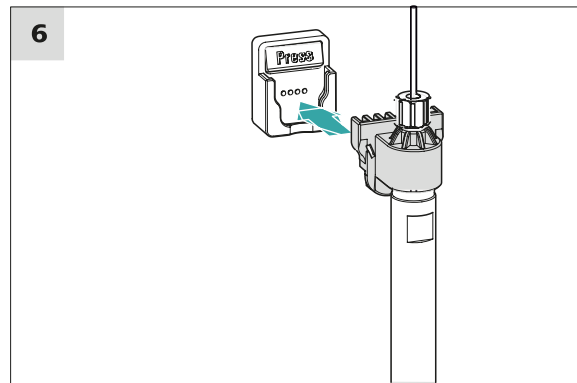
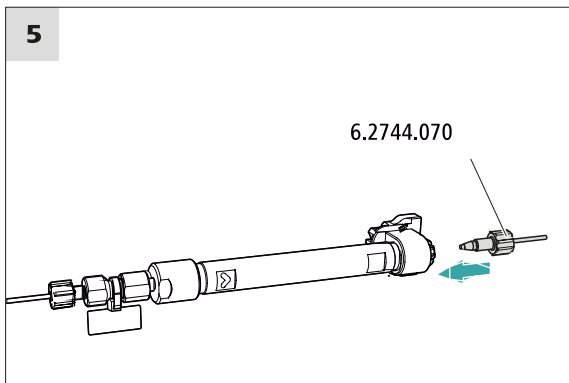
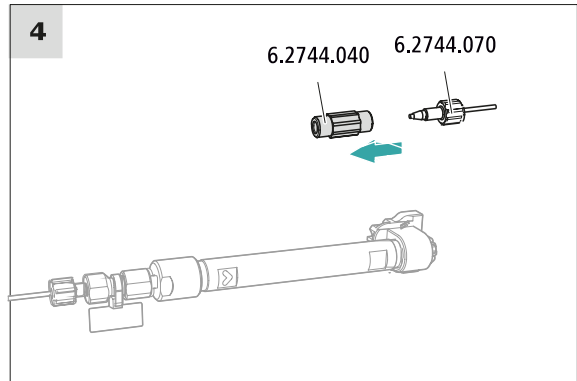
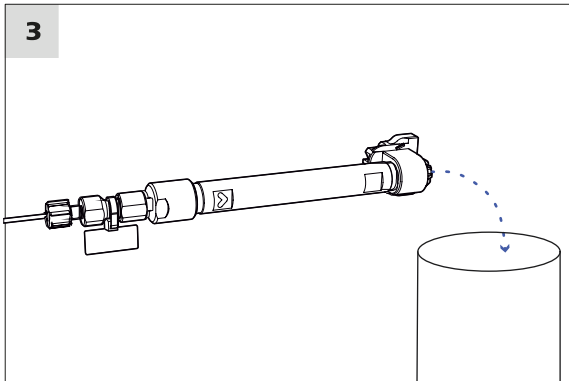
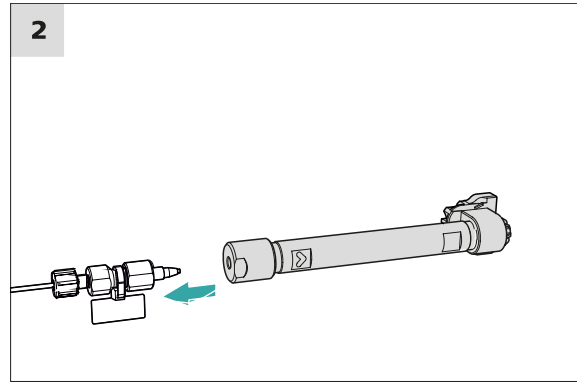
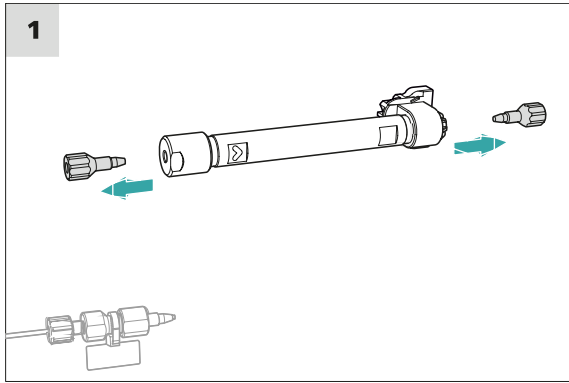

**Connecting the separation column**

- 1 Removing the stoppers**
- Remove the stoppers from the separation column.

## 2 Installing the inlet of the separation column



### CAUTION

When inserting the column, ensure that it is inserted correctly based on the marked flow direction.

There are three options:

- Attach the column inlet directly onto the guard column or,
- if the guard column is connected to the separation column using a connection capillary: Connect the column inlet to the guard column outlet capillary using a PEEK pressure screw (6.2744.070) or,
- if no guard column is used (not recommended): Connect the column inlet capillary to the inlet of the separation column using a short pressure screw (6.2744.070).

## 3 Rinsing the separation column

- Place a beaker under the outlet of the separation column.
- Start manual control in MagIC Net and select the high-pressure pump: **Manual ► Manual control ► Pump**
  - **Flow:** Increase gradually up to the flow rate recommended in the column leaflet.
  - **On**
- Rinse the separation column with eluent for approx. 10 minutes.
- Stop the high-pressure pump in the manual control in MagIC Net again: **Off**.

## 4 Removing the coupling

- Remove the coupling (6.2744.040) from the column outlet capillary.

## 5 Installing the outlet of the separation column

- Fasten the column outlet capillary to the column outlet using a short PEEK pressure screw (6.2744.070).

## 6 Inserting the separation column

- Insert the separation column with the chip into the column holder until you hear it snap in place.

The separation column is now detected by MagIC Net.

## 4.3 Conditioning

In the following cases, the system must be conditioned with eluent until a stable baseline has been reached:

- After installation
- After each time the instrument is switched on
- After each eluent change



### NOTE

The conditioning time can lengthen considerably after changing the eluent.

### Conditioning the system

#### 1 Preparing the software



### CAUTION

Ensure that the configured flow rate is not higher than the flow rate permitted for the corresponding column (refer to the column leaflet and chip data record).

- Start the **MagIC Net** computer program.
- Open the **Equilibration** tab in MagIC Net: **Workplace ► Run ► Equilibration**.
- Select (or create) a suitable method.  
Also see: *MagIC Net Tutorial* and online help.

#### 2 Preparing the instrument

- Ensure that the column is inserted correctly in relation to the flow direction marked on the sticker (arrow has to point in the direction of flow).
- Ensure that the eluent aspiration tubing is immersed in the eluent and that there is enough eluent in the eluent bottle.

#### 3 Starting equilibration

- Start the equilibration in MagIC Net: **Workplace ► Run ► Equilibration ► Start HW**.

- Visually inspect whether all capillaries and their connections from the high-pressure pump to the detector are leak-tight. If eluent is leaking out anywhere, tighten the corresponding pressure screw further, or loosen the pressure screw, check the end of the capillary and shorten it using the capillary cutter if necessary and retighten the pressure screw.

#### **4 Conditioning the system**

Continue rinsing the system with eluent until the desired stability level has been attained for the baseline.

The instrument is now ready for measuring samples.



## 5 Applications

### 5.1 Standard chromatogram

Sample preparation: -

Amperometric detection: Measuring mode: PAD; working electrode: Au, 3 mm; reference electrode: Pd

Potential profile

	Duration [ms]	Total duration [ms]	Potential [V]
1	300	300	0.05
2	50	350	0.55
3	200	550	-0.10

Temperature: 30 °C

Loop: 4 mm: 20 µL

2 mm: 5 µL

Eluent: 100 mmol/L of sodium hydroxide, 10 mmol/L of sodium acetate

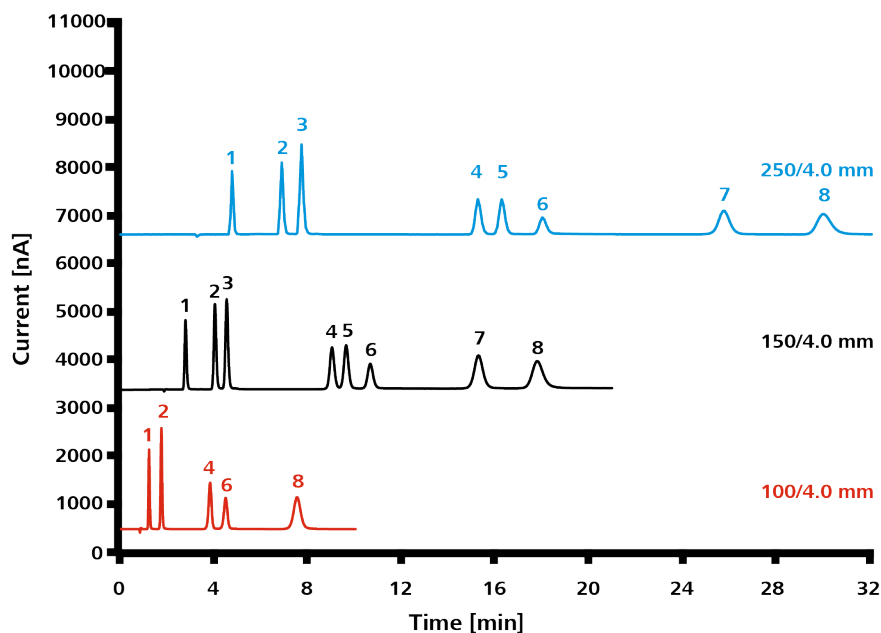

Carb 2	100/4.0	150/4.0	250/4.0
Flow rate [mL/min]	0.8	0.5	0.5
1 2.5 mg/L inositol	x	x	x
2 5 mg/L of arabitol	x	x	x
3 5 mg/L of sorbitol		x	x
4 5 mg/L of glucose	x	x	x
5 5 mg/L of xylose		x	x
6 5 mg/L of fructose	x	x	x
7 10 mg/L of lactose		x	x
8 15 mg/L of sucrose	x	x	x

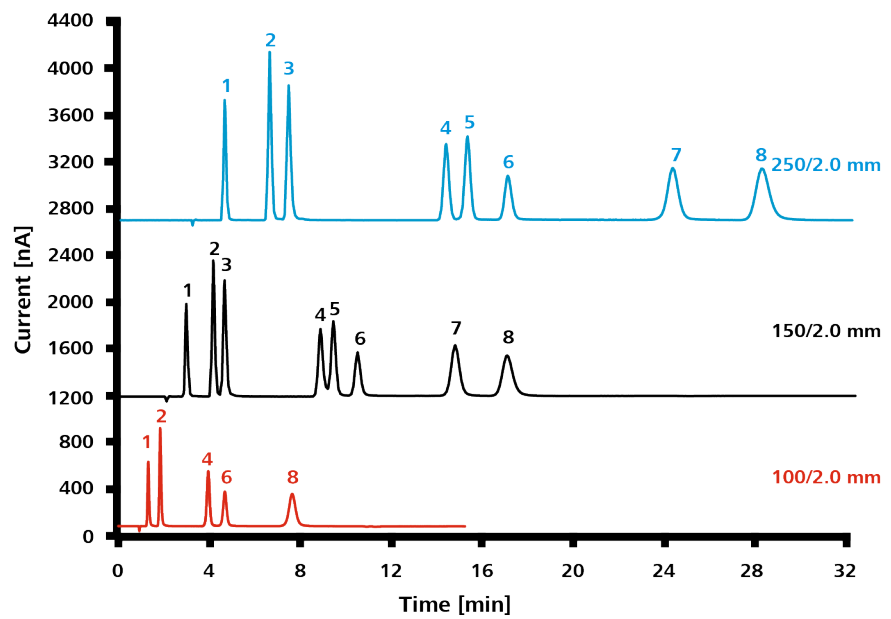

Carb 2	100/2.0	150/2.0	250/2.0
Flow rate [mL/min]	0.2	0.13	0.13
1 2.5 mg/L inositol	x	x	x
2 5 mg/L of arabitol	x	x	x
3 5 mg/L of sorbitol		x	x
4 5 mg/L of glucose	x	x	x
5 5 mg/L of xylose		x	x
6 5 mg/L of fructose	x	x	x
7 10 mg/L of lactose		x	x
8 15 mg/L of sucrose	x	x	x



## 5.2 Effects of modifying the flow rate

### 4-mm column

Sample preparation: -

Amperometric detection:

Measuring mode: PAD; working electrode: Au, 3 mm; reference electrode: Pd

Potential profile

	Duration [ms]	Total duration [ms]	Potential [V]
1	300	300	0.05
2	50	350	0.55
3	200	550	-0.10

Column:

Metrosep Carb 2 - 150/4.0

Flow rate:

0.5, 0.8, 1.2 mL/min

Temperature:

30 °C

Loop:

20  $\mu$ L

Eluent:

100 mmol/L of sodium hydroxide, 10 mmol/L of sodium acetate

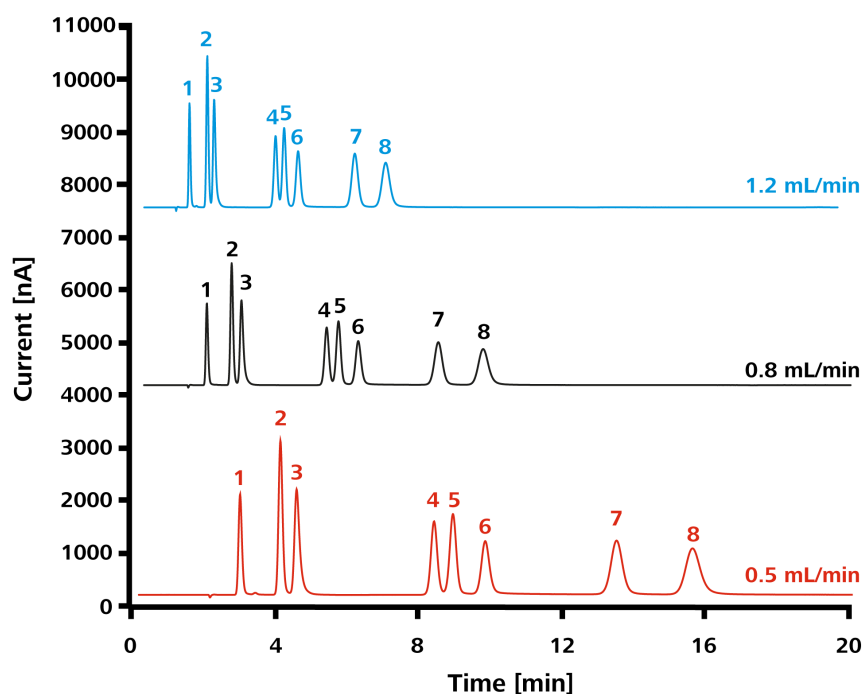

---

**Metrosep Carb 2 - 150/4.0**

---

1	2.5 mg/L inositol	5	5 mg/L of xylose
2	5 mg/L of arabitol	6	5 mg/L of fructose
3	5 mg/L of sorbitol	7	10 mg/L of lactose
4	5 mg/L of glucose	8	15 mg/L of sucrose

---

**2-mm column***Sample preparation:*

-

*Amperometric detection:*

Measuring mode: PAD; working electrode: Au, 3 mm; reference electrode: Pd

*Potential profile*

	<b>Duration [ms]</b>	<b>Total duration [ms]</b>	<b>Potential [V]</b>
1	300	300	0.05
2	50	350	0.55
3	200	550	-0.10

---

*Column:*

Metrosep Carb 2 - 150/2.0

*Flow rate:*

0.13, 0.23, 0.33, 0.43 mL/min

*Temperature:*

30 °C

*Loop:*

5 µL

*Eluent:*

100 mmol/L of sodium hydroxide, 10 mmol/L of sodium acetate

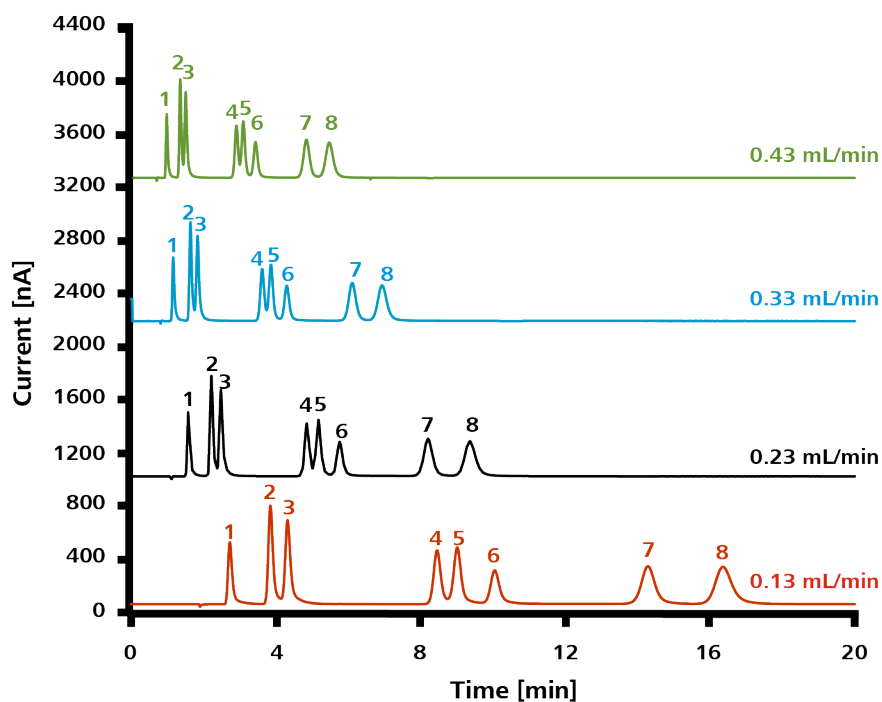

---

**Metrosep Carb 2 - 150/4.0**

---

1	2.5 mg/L inositol	5	5 mg/L of xylose
2	5 mg/L of arabitol	6	5 mg/L of fructose
3	5 mg/L of sorbitol	7	10 mg/L of lactose
4	5 mg/L of glucose	8	15 mg/L of sucrose

---

### 5.3 Effects of temperature

Sample preparation: -

Amperometric detection: Measuring mode: PAD; working electrode: Au, 3 mm; reference electrode: Pd

Potential profile

	Duration [ms]	Total duration [ms]	Potential [V]
1	300	300	0.05
2	50	350	0.55
3	200	550	-0.10

Column: Metrosep Carb 2 - 150/4.0

Flow rate: 0.5 mL/min

Temperature: 20, 30, 45, 60 °C

Loop: 20  $\mu$ L

Eluent: 100 mmol/L of sodium hydroxide, 10 mmol/L of sodium acetate

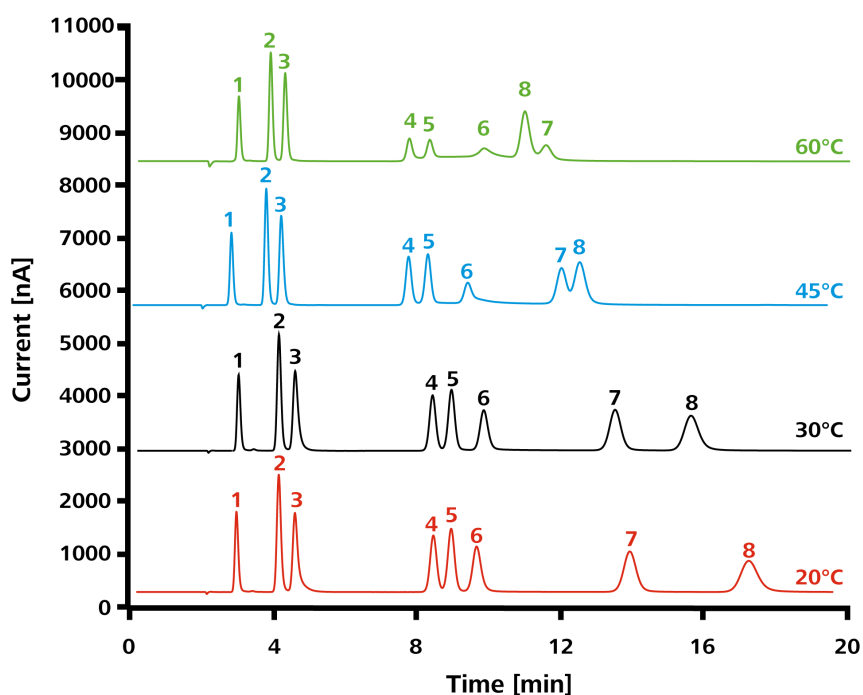

---

**Metrosep Carb 2 - 150/4.0**

---

1	2.5 mg/L inositol	5	5 mg/L of xylose
2	5 mg/L of arabitol	6	5 mg/L of fructose
3	5 mg/L of sorbitol	7	10 mg/L of lactose
4	5 mg/L of glucose	8	15 mg/L of sucrose

---

The background current increases at a constant rate as temperature increases. If the background current is just 130 nA at 20 °C, it increases to more than 750 nA at 60 °C. Generally, higher temperatures result in shorter retention times. The sensitivity of fructose drops significantly if analysis is carried out at temperatures above 45 °C. Sucrose elutes before lactose at 60 °C.



## 5.4 Variation of the eluent

### Variation of sodium hydroxide concentration

Sample preparation: -

Amperometric detection:

Measuring mode: PAD; working electrode: Au, 3 mm; reference electrode: Pd

Potential profile

	Duration [ms]	Total duration [ms]	Potential [V]
1	300	300	0.05
2	50	350	0.55
3	200	550	-0.10

Column:

Metrosep Carb 2 - 150/4.0

Flow rate:

0.5 mL/min

Temperature:

30 °C

Eluent:

5, 10, 50, 100 mmol/L of sodium hydroxide, 0 mmol/L of sodium acetate

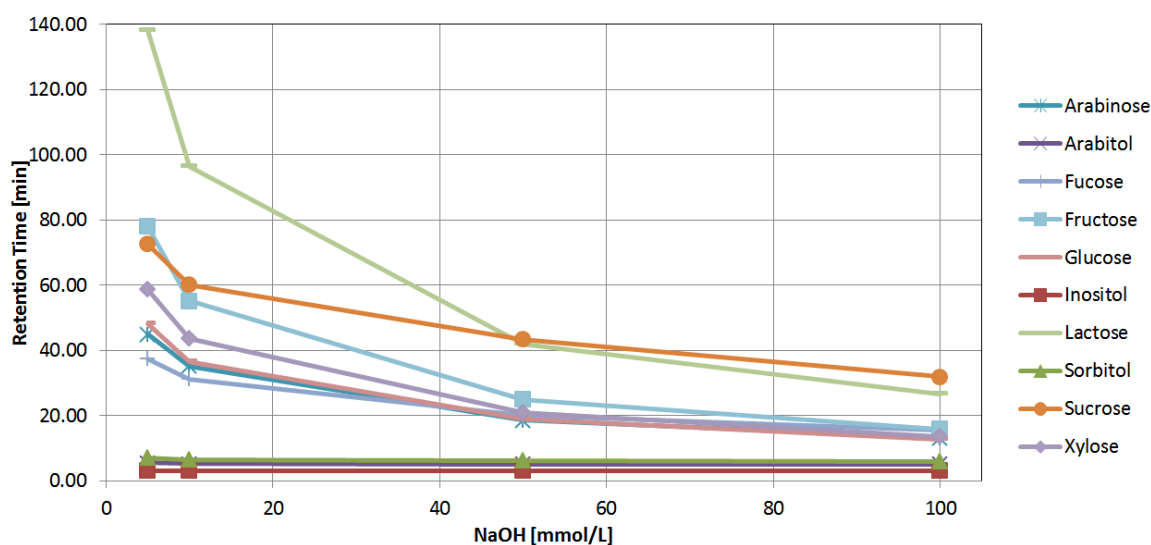

The retention time is drastically reduced as sodium hydroxide concentration increases, especially for monosaccharides and disaccharides. Alcohol sugars are only minimally affected. Sucrose and lactose switch elution order.



### Variation of sodium acetate concentration in addition to 150 mmol/L of sodium hydroxide

Sample preparation: -

Amperometric detection: Measuring mode: PAD; working electrode: Au, 3 mm; reference electrode: Pd

Potential profile

	Duration [ms]	Total duration [ms]	Potential [V]
1	300	300	0.05
2	50	350	0.55
3	200	550	-0.10

Column: Metrosep Carb 2 - 150/4.0

Flow rate: 0.5 mL/min

Temperature: 30 °C

Eluent: 150 mmol/L of sodium hydroxide, 2, 5, 7, 10 mmol/L of sodium acetate

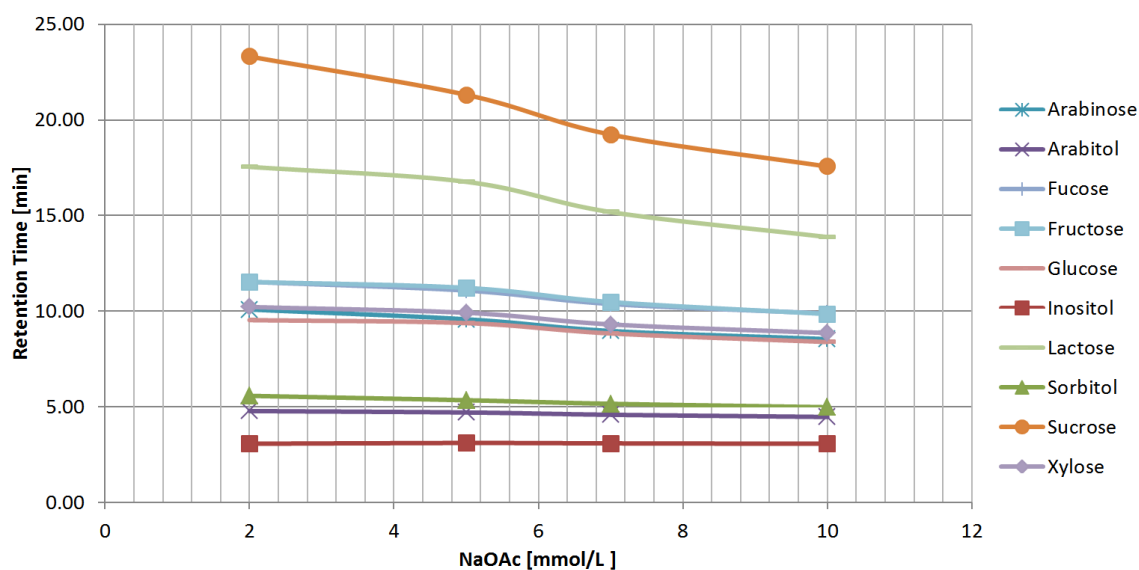

The retention time decreases somewhat more substantially for disaccharides than for monosaccharides as the sodium acetate concentration increases.

Alcohol sugars are only minimally affected.



### Variation of sodium hydroxide concentration in addition to 10 mmol/L of sodium acetate

Sample preparation: -

Amperometric detection:

Measuring mode: PAD; working electrode: Au, 3 mm; reference electrode: Pd

Potential profile

	Duration [ms]	Total duration [ms]	Potential [V]
1	300	300	0.05
2	50	350	0.55
3	200	550	-0.10

Column:

Metrosep Carb 2 - 150/4.0

Flow rate:

0.5 mL/min

Temperature:

30 °C

Eluent:

2, 5, 10, 20, 50, 100, 200 mmol/L of sodium hydroxide, 10 mmol/L of sodium acetate

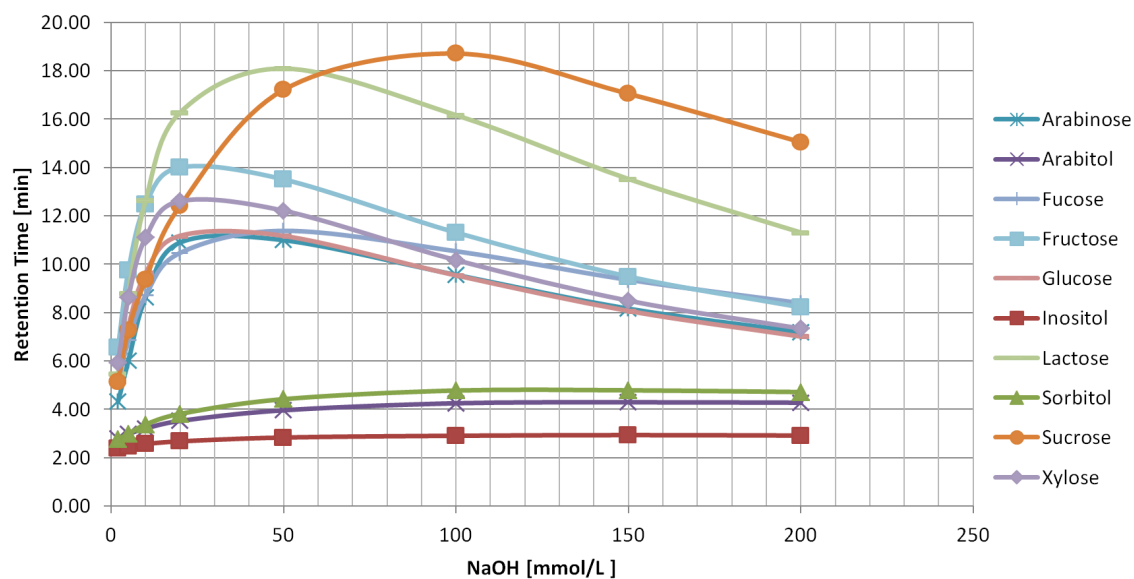

The variation of the sodium hydroxide concentration affects the pH and, as a result, the charge of the sugar in the buffer solution. It is important to note the significant variations in retention times based on the ratio of sodium hydroxide to sodium acetate.



For instance, sucrose and lactose as well as fucose and xylose switch elution orders.

## 5.5 Determination of primary sugar content in apple juice

*Sample preparation:* Dilution 1:2000

*Amperometric detection:* Measuring mode: PAD; working electrode: Au, 3 mm; reference electrode: Pd

*Potential profile:*

	Duration [ms]	Total duration [ms]	Potential [V]
1	300	300	0.05
2	50	350	0.55
3	200	550	-0.10

*Column:* Metrosep Carb 2 - 150/4.0

*Flow rate:* 0.5 mL/min

*Temperature:* 30 °C

*Loop:* 20 µL

*Eluent:* 100 mmol/L of sodium hydroxide, 10 mmol/L of sodium acetate

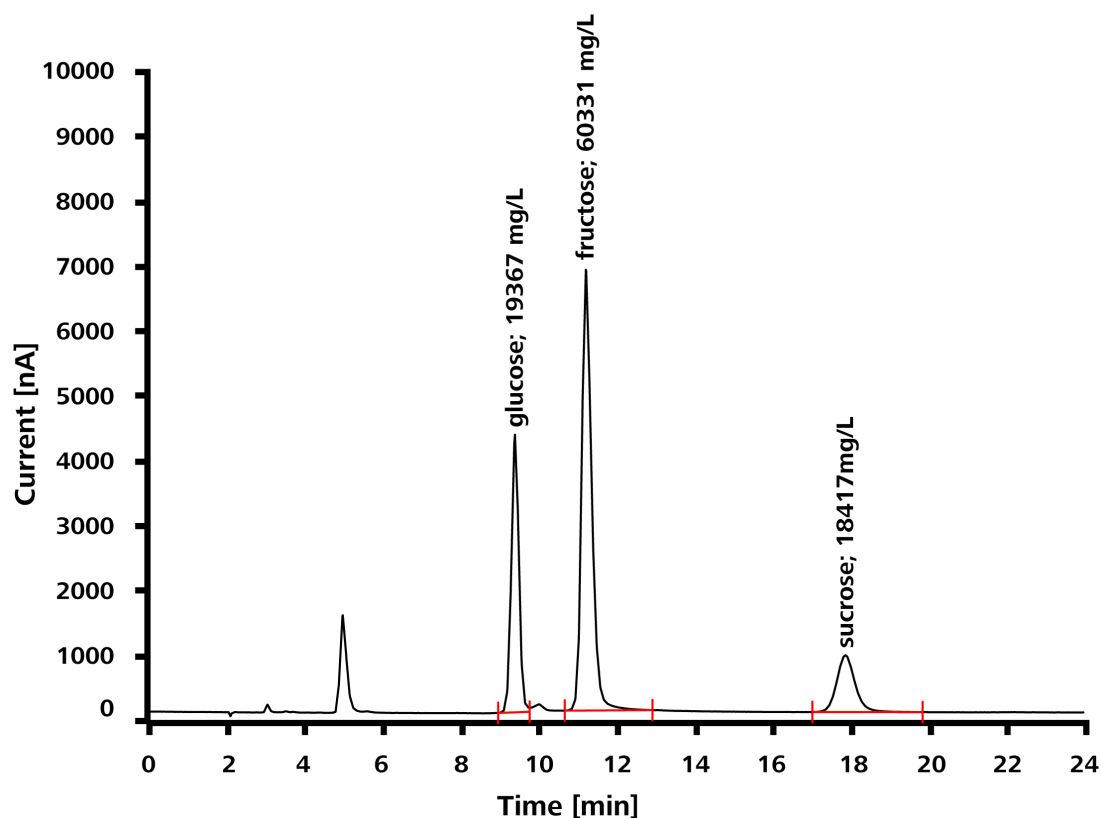

## 5.6 Air particle analysis of tracers such as levoglucosan from wood fires

*Sample preparation:* Aqueous filter extraction

*Amperometric detection:* Measuring mode: PAD; working electrode: Au, 3 mm; reference electrode: Pd

*Potential profile:*

	Duration [ms]	Total duration [ms]	Potential [V]
1	300	300	0.05
2	50	350	0.55
3	200	550	-0.10

*Column:* Metrosep Carb 2 - 150/4.0

*Flow rate:* 1.0 mL/min

*Temperature:* 45 °C

*Loop:* 100 µL

Eluent: 10 mmol/L of sodium hydroxide

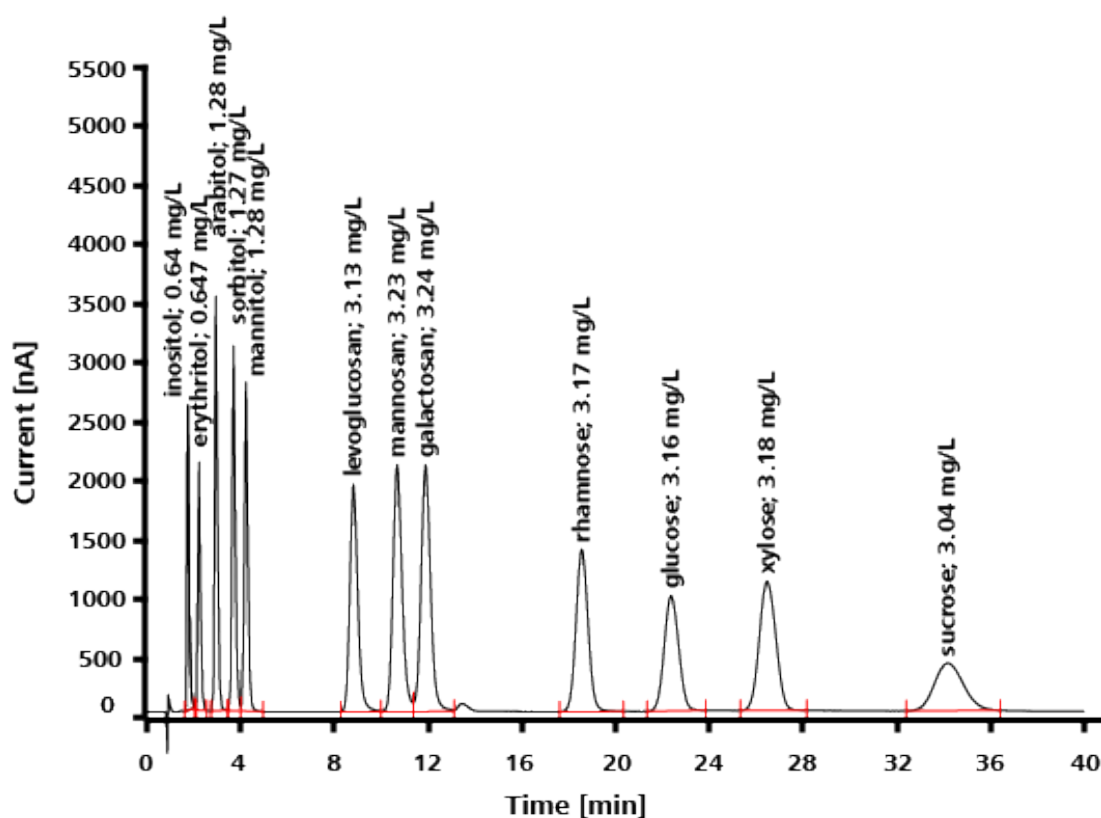

## 5.7 Cosmetic product analysis

Sample preparation: Extraction in the aqueous phase

Amperometric detection: Measuring mode: PAD; working electrode: Au, 3 mm; reference electrode: Pd

Potential profile:

	Duration [ms]	Total duration [ms]	Potential [V]
1	300	300	0.05
2	50	350	0.55
3	200	550	-0.10

Column: Metrosep Carb 2 - 150/4.0

Flow rate: 0.7 mL/min

Temperature: 35 °C

Loop: 20 µL



*Eluent:* 5 mmol/L of sodium hydroxide, 2 mmol/L of sodium acetate

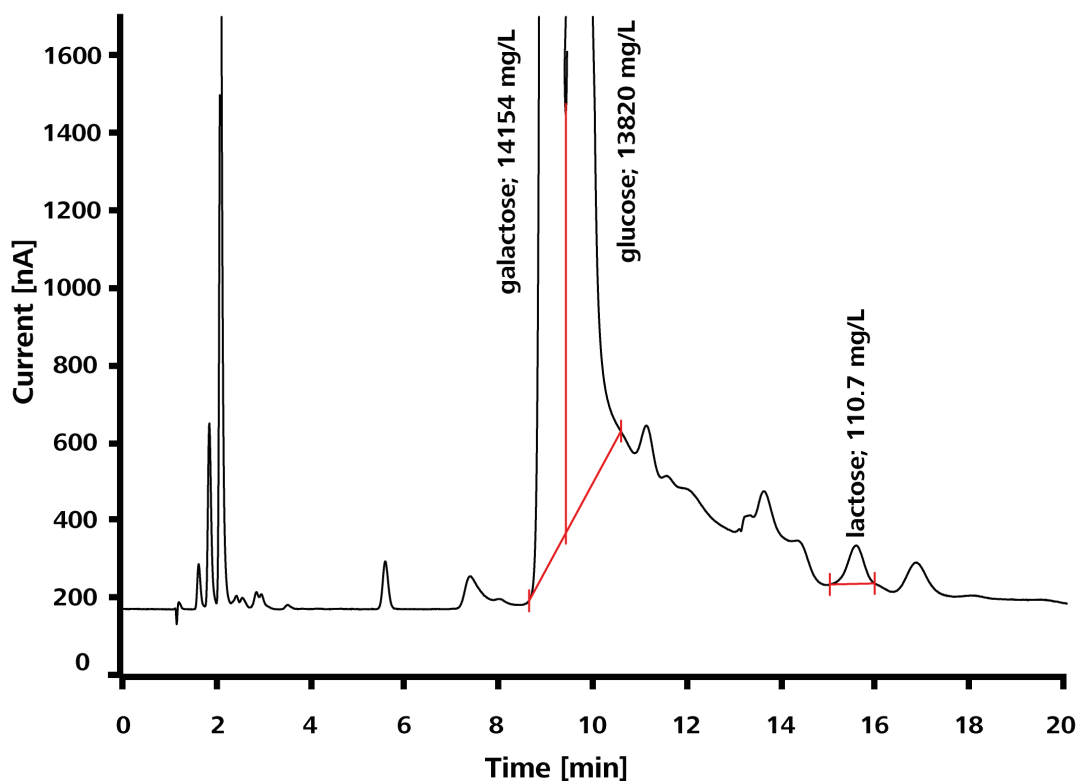

## 5.9 Multi-component analysis

*Sample preparation:* -

*Amperometric detection:* Measuring mode: PAD; working electrode: Au, 3 mm; reference electrode: Pd

*Potential profile:*

	Duration [ms]	Total duration [ms]	Potential [V]
1	300	300	0.05
2	50	350	0.55
3	200	550	-0.10

*Column:* Metrosep Carb 2 - 250/4.0

*Flow rate:* 0.6 mL/min

*Temperature:* 40 °C

*Loop:* 20 µL

Eluent: 5 mmol/L of sodium hydroxide, 2 mmol/L of sodium acetate

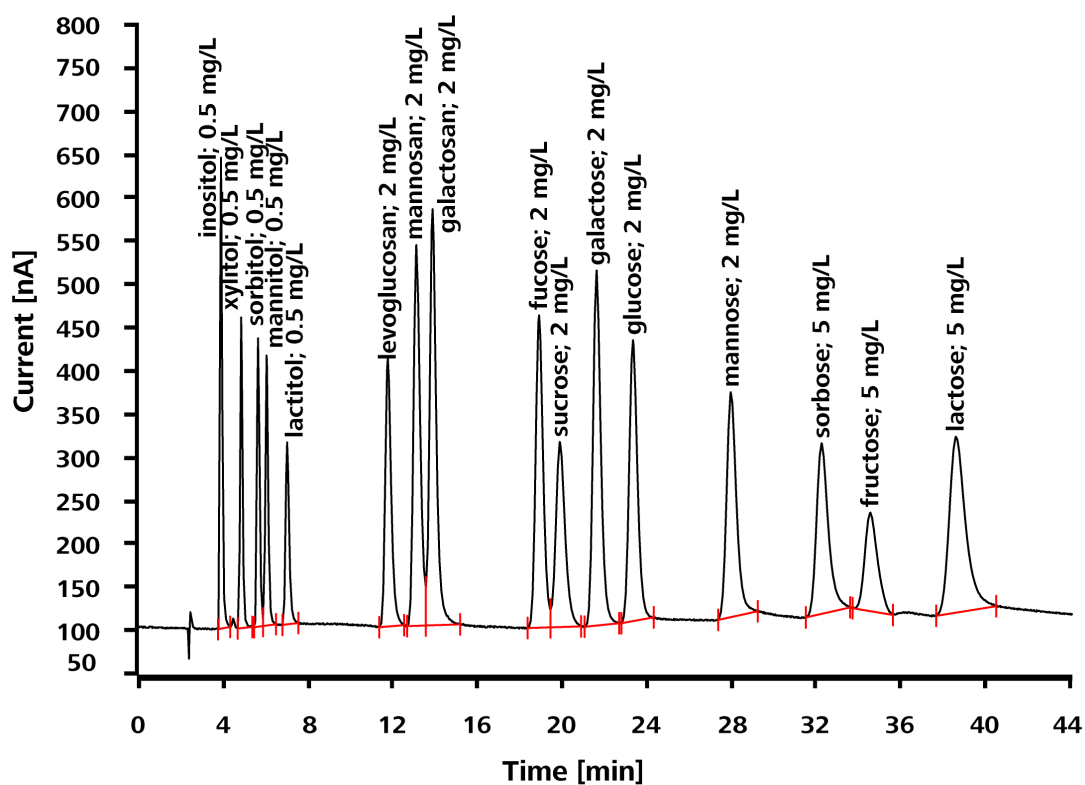

## 5.10 Yogurt

*Sample preparation:* Add ultrapure water to 0.5 g of yogurt until reaching 100 g, stir, carry out Inline Dialysis and Inline Dilution 1:50

*Amperometric detection:* Measuring mode: PAD; working electrode: Au, 3 mm; reference electrode: Pd

*Potential profile:*

	Duration [ms]	Total duration [ms]	Potential [V]
1	300	300	0.05
2	50	350	0.55
3	200	550	-0.10

*Column:* Metrosep Carb 2 - 150/2.0

*Flow rate:* 0.13 mL/min

*Temperature:* 40 °C

*Loop:* 5 µL

*Eluent:* 5 mmol/L of sodium hydroxide, 2 mmol/L of sodium acetate

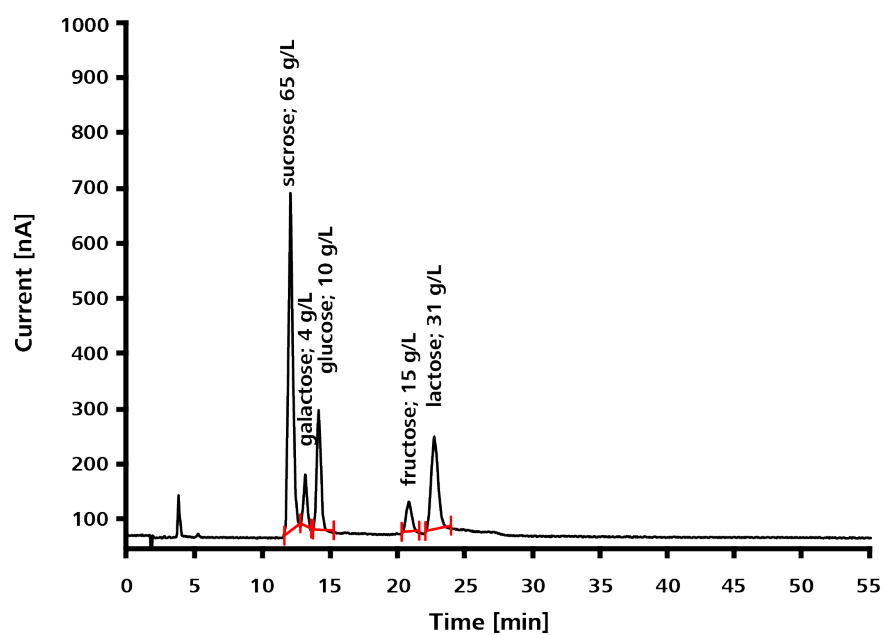

## 5.11 Sea water analysis with UV detection

*Sample preparation:* Inline Ultrafiltration

*Detection:* UV/VIS detection at  $218 \pm 5$  nm

*Column:* Metrosep Carb 2 - 100/2.0

*Flow rate:* 0.375 mL/min

*Temperature:* 30 °C

*Loop:* 20  $\mu$ L

*Eluent:* 10 g/L NaCl

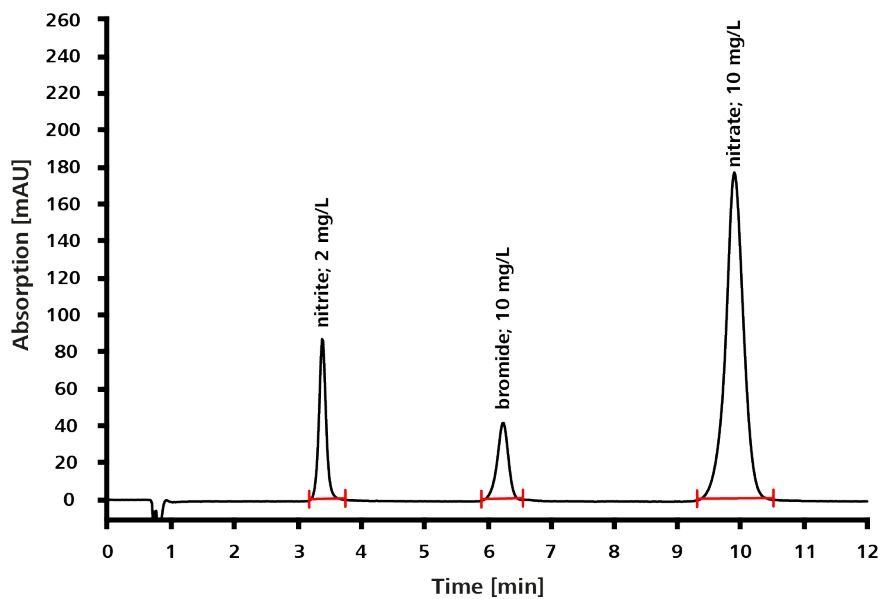

## 5.12 Determination of chromium species

*Sample preparation:* Samples in eluent and addition of 20  $\mu\text{mol/L}$  EDTA, incubation period of 60 min at 60 °C

*Detection:* ICP-MS, Agilent ICP-MS 7500ce collision cell (He) mode

*Column:* Metrosep Carb 2 - 100/2.0

*Flow rate:* 0.2 mL/min

*Temperature:* 20 °C

*Loop:* 20  $\mu\text{L}$

*Eluent:* 100 mmol/L ammonium nitrate, pH = 9

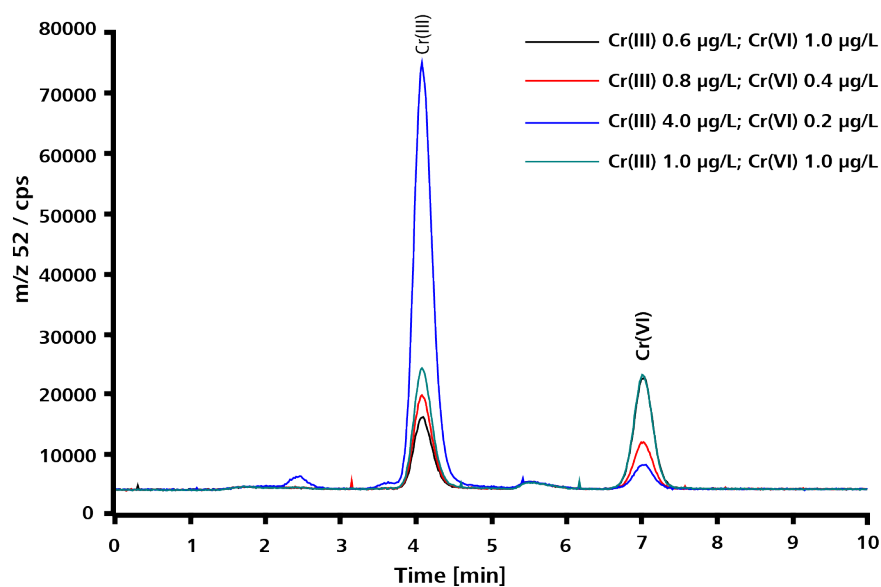

The chromatograms show different ratio for the mixed solutions of the Cr(III) and Cr(VI) species in µg/L.

### 5.13 Use of Metrosep CO<sub>3</sub><sup>2-</sup> Trap 1 – 100/4.0

The Metrosep CO<sub>3</sub><sup>2-</sup> Trap 1 - 100/4.0 (6.1015.300) is used to eliminate carbonate impurities from hydroxide eluents. Carbonate contaminants in low concentration hydroxide eluents intensify the elution leading to shorter retention times.

The use of this trap column leads to stable retention times by removing carbonate.

This trap column is typically used for eluent concentrations of 5 to 40 mmol/L of hydroxide eluent.

The column is inserted in the eluent flow between the high-pressure pump and the injection valve.



## 5.14 Use of Metrosep $\text{BO}_3^{3-}$ Trap 1 – 100/4.0

The Metrosep  $\text{BO}_3^{3-}$  Trap 1 - 100/4.0 (6.1015.200) is used to eliminate traces of borate from hydroxide eluents. Borate impurities can contribute to the deterioration of peak symmetries.

The use of this trap column leads to sharper peaks (such as for sorbitol) by removing borate.

The column is inserted in the eluent flow between the high-pressure pump and the injection valve.

## 6 Troubleshooting

### 6.1 Regeneration



#### CAUTION

Do not regenerate the column as a preventive measure!

Each regeneration process causes stress on the separation column and reduces its service life see "*Regenerating separation columns*", page 6.

#### Problem

- Backpressure increases
- Double peaks occur
- Tailing effects occur
- The retention times become shorter
- The resolution deteriorates

#### Correction

#### Regenerating the separation column

Start by replacing the guard column if the above problems occur. Only regenerate the separation column as described below if this measure does not help.

##### 1 Disconnecting the separation column from the IC system

Disconnect the separation column outlet from the detector inlet.

##### 2 Regenerating the separation column

The separation column has to be regenerated differently depending on the type of contamination:

Table 6 Organic contamination

	4 mm	2 mm
Solution	100 mL of standard eluent in 50% acetonitrile	25 mL of standard eluent in 50% acetonitrile
Flow direction	in the flow direction	in the flow direction
Flow rate	0.5 mL/min	0.13 mL/min



Duration	e.g. for 6.1090.420: approx. 3 h	e.g. for 6.01090.220: approx. 3 h
----------	-------------------------------------	--------------------------------------

Table 7 *Inorganic contamination*

	4 mm	2 mm
Solution	100 mmol/L sodium hydroxide and 500 mmol/L sodium acetate	100 mmol/L sodium hydroxide and 500 mmol/L sodium acetate
Flow direction	in the flow direction	in the flow direction
Flow rate	0.5 mL/min	0.13 mL/min
Duration	e.g. for 6.1090.430: at least 7 h	e.g. for 6.01090.230: at least 7 h

### 3 Rinsing the separation column

Rinse the separation column with standard eluent (e.g. 6.1090.430 at least for 7 h).

## 6.2 Decreasing resolution / peak shapes

### Problem

The resolution of peaks deteriorates or peak shapes are asymmetrical.

### Causes and prevention

Causes	Prevention/correction
The separation column has been overloaded	<p>The separation column can be overloaded by factors such as a high salt content in the sample matrix.</p> <ul style="list-style-type: none"> <li>▪ Dilute the sample.</li> <li>▪ Inject less sample.</li> </ul>
Carbonate accumulates on the column	<p>Rinse the carbonate out of the column as follows:</p> <ul style="list-style-type: none"> <li>▪ <b>Solution:</b> 300 mmol/L of sodium hydroxide eluent</li> <li>▪ <b>Flow rate:</b> 6.1090.4x0: 1 mL/min 6.01090.2x0: 0.25 mL/min</li> <li>▪ <b>Duration:</b> 14 h</li> </ul>



Causes	Prevention/correction
There are dead volumes in the IC system	<ul style="list-style-type: none"> <li>▪ Check that all of the capillaries have a diameter of <math>\leq 0.25</math> mm (6.1831.010). If they do not, replace those capillaries with smaller capillaries.</li> <li>▪ Use capillaries with a diameter of 0.18 mm (6.01806.000) for 2.0-mm columns.</li> <li>▪ Check that all of the capillaries have been installed correctly. The step-by-step installation process is shown in the IC Maintenance multimedia guide.</li> </ul>

### 6.3 Unstable retention times

#### *Problem*

The retention times are unstable.

#### *Causes and prevention*

Causes	Prevention/correction
Carbonate in the eluent	<p>Avoid letting sodium hydroxide eluents and concentrated stock solutions come into contact with air whenever possible. They absorb carbon dioxide from the air which is present in the alkaline solution in the form of carbonate. Compared to hydroxide, the eluent ionic strength of carbonate is higher and, consequently, it shortens retention times.</p> <ul style="list-style-type: none"> <li>▪ Always store the eluent bottle and bottle with stock solution well sealed.</li> <li>▪ Always use a CO<sub>2</sub> adsorber.</li> </ul>
Air bubbles in the eluent	<p>Air bubbles make the eluent flow unstable. Backpressure is one indicator of unstable flow. Backpressure should remain stable within <math>\pm 0.1</math> MPa.</p> <ul style="list-style-type: none"> <li>▪ Deaerate the high-pressure pump.</li> <li>▪ Use an eluent degasser.</li> </ul>



## 6.4 Unknown peaks

### *Problem*

The chromatogram contains wide, unknown peaks.

### *Causes and prevention*

<b>Causes</b>	<b>Prevention/correction</b>
Analytes eluting late	<p>Some wider, unknown peaks can be the result of sample components eluting late. In these cases, this is the result of the previous injection.</p> <ul style="list-style-type: none"> <li>▪ Extend the chromatogram duration.</li> </ul>

## 6.5 Increasing backpressure

### *Problem*

The backpressure increases.

### *Causes and prevention*

<b>Causes</b>	<b>Prevention/correction</b>
Particles on the guard column	<ul style="list-style-type: none"> <li>▪ Replace the guard column.</li> </ul>
Particles on the separation column	<p>Rinse the separation column in the direction opposite to the flow direction.</p> <ul style="list-style-type: none"> <li>▪ Hold the column outlet in a beaker.</li> <li>▪ Rinse the separation column for approximately 1 h.</li> <li>▪ Install the separation column back in the flow direction.</li> </ul>
Particles in the sample	<ul style="list-style-type: none"> <li>▪ Sample preparation, e.g. removing particles through Inline Ultrafiltration.</li> </ul>



## 7 Literature

We recommend the following literature for more detailed information:

- Application Note P-54 Anhydrosugars besides sugaralcohols and sugars on Metrosep Carb 2 - 150/4.0
- Application Note P-55 Lactose in lactose-free milk applying Metrosep Carb 2 - 150/4.0
- Metrosep Carb 2 brochure (8.107.5002)
- Application Note P-60 Ethylene and propylene glycol applying pulsed amperometric detection
- Application Note P-61 Sugar analysis in honey according to the EU regulation applying pulsed amperometric detection
- Application Note P-62 Sugars and sugar alcohols in an apple drink applying pulsed amperometric detection
- Application Note P-63 Mannitol, rhamnose, lactulose, and lactose in blood serum applying pulsed amperometric detection (PAD)
- Application Note P-64 Separation of sugars and sugar acids applying a low-pressure gradient
- Application Note P-65 Sugar and sugar alcohols including saccharose and cellobiose
- Application Note P-67 Sorbitol and sucrose in soap applying pulsed amperometric detection
- Application Note U-71 Nitrite, bromide and nitrate in artificial seawater applying UV/VIS detection
- Application Report Metrohm Info 2/2015, Are you made of sugar? MI-2015-2-AP-1
- Kappes, S. and Zierfels, G. Are You Made of Sugar? Chromatography Today, Jun 3, 2016, pp 20–2



# Index

**B**

Baseline	
Condition .....	19

**C**

Column	
see "Separation column" ....	15
Conditioning .....	19

**E**

Eluent .....	9
Equilibration .....	18

**F**

Flow rate .....	2
-----------------	---

**G**

Guard column	
Installation .....	12
Rinse .....	14

**I**

IC column	
see "Separation column" ....	15
Installation	
Guard column .....	12
Separation column .....	15

**O**

Order number .....	1
--------------------	---

**R**

Rinse	
Guard column .....	14
Separation column .....	17

**S**

Separation column	
Installation .....	15
Rinse .....	17
Specification .....	2
Storage .....	3